

ASSEMBLY INSTRUCTION

SKU CODE: (WF311271-WF311272)

INSTRUCTIONS DE MONTAGE

SKU NUMBER: (WF311271-WF311272)

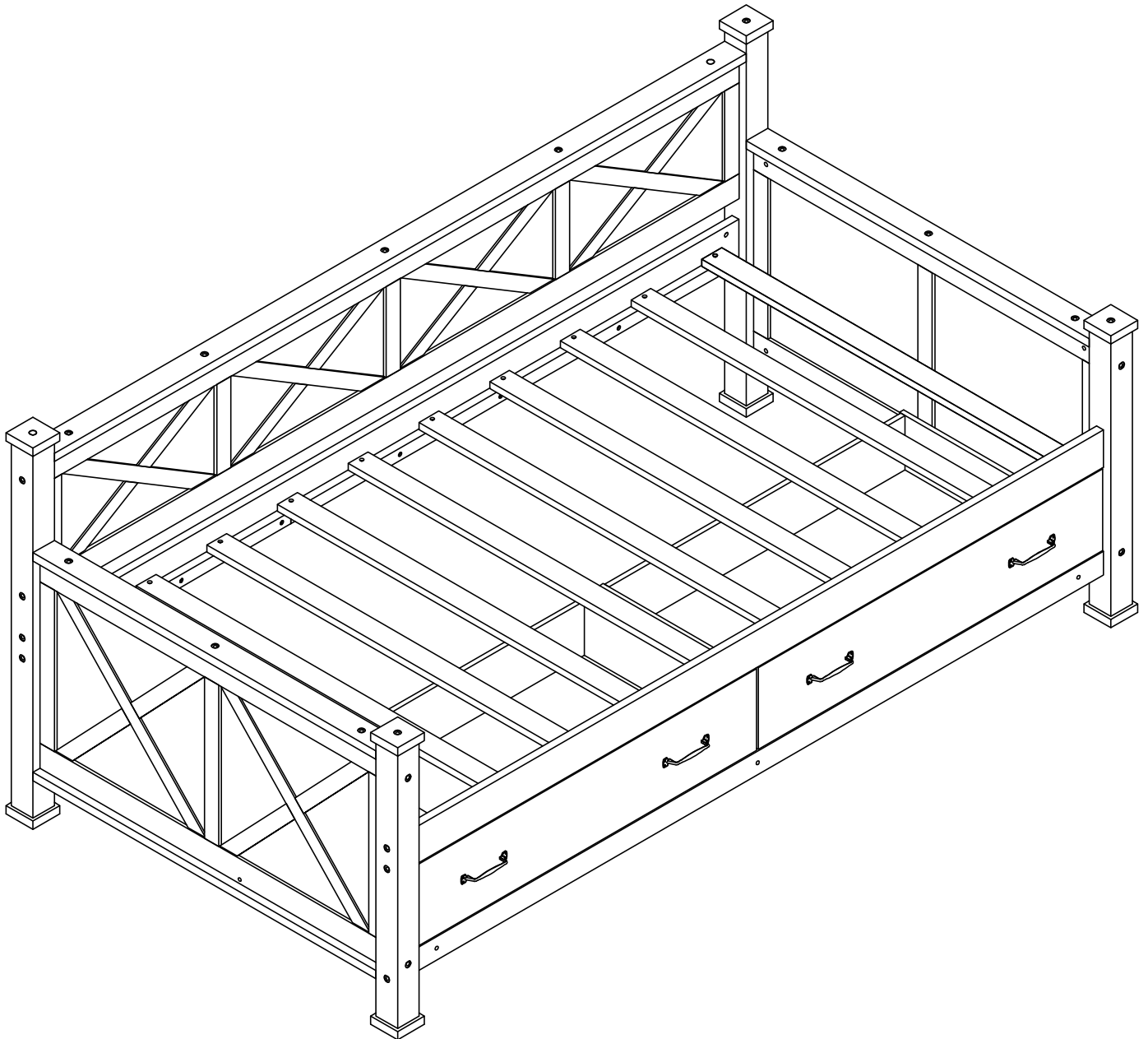

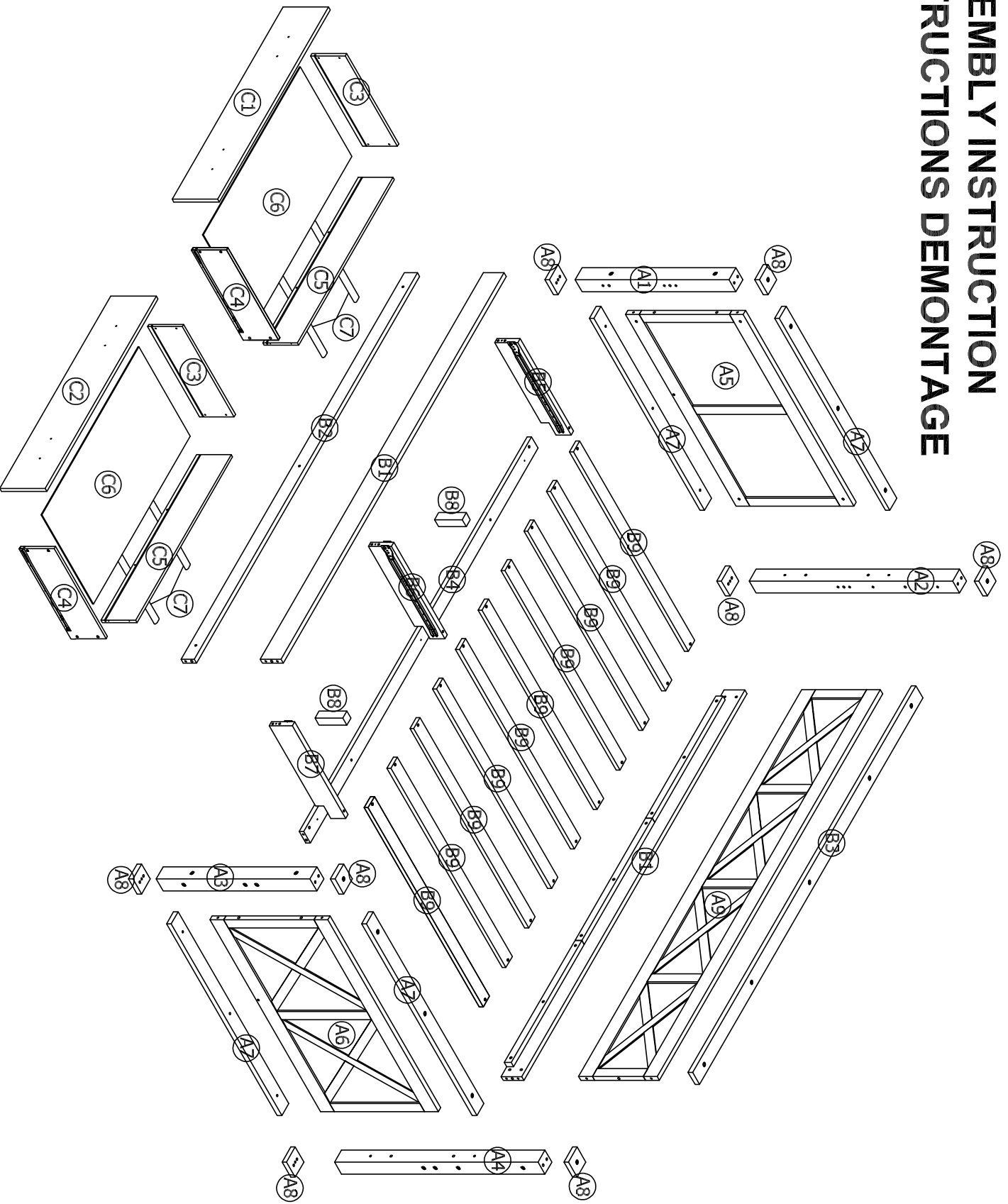

ASSEMBLY INSTRUCTION INSTRUCTIONS DEMONTAGE





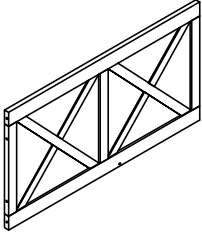
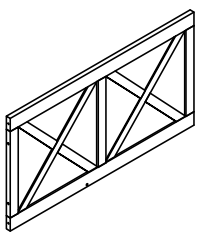
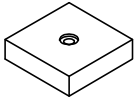
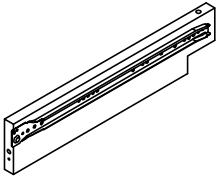
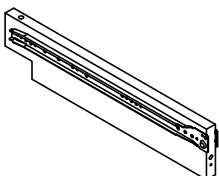
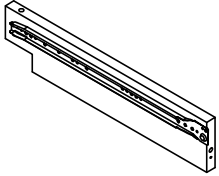

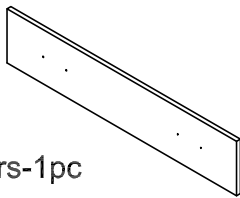
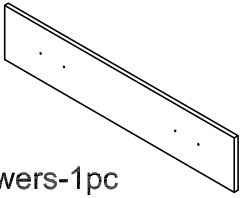
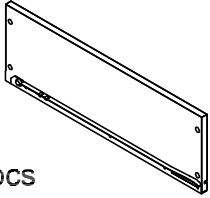
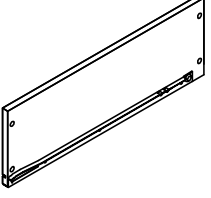
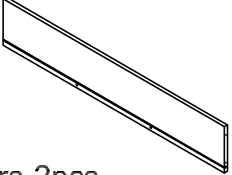
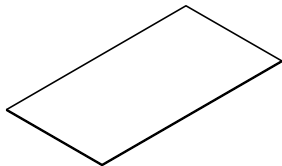
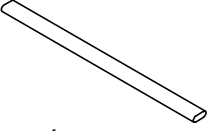
Part List (Box 1-WF311271)

Liste des pièces

<p>A5</p>  <p>Panel-1pc Planche</p>	<p>A6</p>  <p>Panel-1pc Planche</p>	<p>A8</p>  <p>WoodBar-8pcs Barres de bois</p>
<p>B5</p>  <p>WoodBar-1pc Barres de bois</p>	<p>B6</p>  <p>WoodBar-1pc Barres de bois</p>	<p>B7</p>  <p>WoodBar-1pc Barres de bois</p>
<p>B8</p>  <p>WoodBar-2pcs Barres de bois</p>	<p>C1</p>  <p>Front Drawers-1pc Tiroirs Frontaux</p>	<p>C2</p>  <p>Front Drawers-1pc Tiroirs Frontaux</p>
<p>C3</p>  <p>Side Drawers-2pcs Tiroirs Latéraux</p>	<p>C4</p>  <p>Side Drawers-2pcs Tiroirs Latéraux</p>	<p>C5</p>  <p>Back Drawers-2pcs Tiroirs Arrière</p>
<p>C6</p>  <p>Bottom Drawers-2pcs Tiroirs du Bas</p>	<p>C7</p>  <p>Support Drawers-4pcs Tiroirs de Soutien</p>	



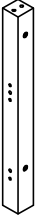

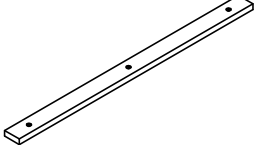
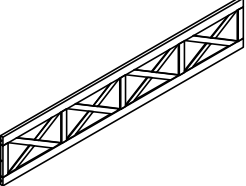
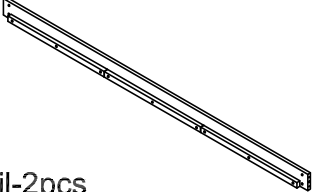
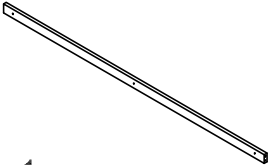
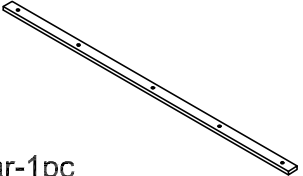
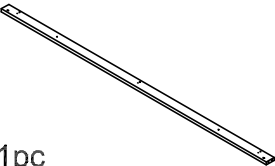
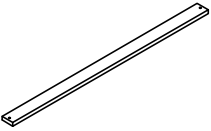

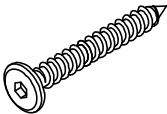
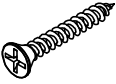
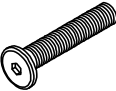

Part List & Hardware List (Box 2-WF311272)

Liste des pièces et liste du matériel

<p>A1</p>  <p>Leg-1pc Jambe</p>	<p>A2</p>  <p>Leg-1pc Jambe</p>	<p>A3</p>  <p>Leg-1pc Jambe</p>
<p>A4</p>  <p>Leg-1pc Jambe</p>	<p>A7</p>  <p>WoodBar-4pcs Barres de bois</p>	<p>A9</p>  <p>Panel-1pc Planche</p>
<p>B1</p>  <p>Side Rail-2pcs Rail latéral</p>	<p>B2</p>  <p>WoodBar-1pc Barres de bois</p>	<p>B3</p>  <p>WoodBar-1pc Barres de bois</p>
<p>B4</p>  <p>WoodBar-1pc Barres de bois</p>	<p>B9</p>  <p>Slats-10pcs Lattes</p>	

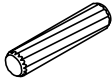
Hardware List (Box 2-WF311272)

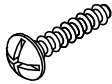
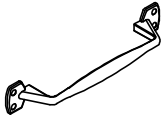
Liste du matériel

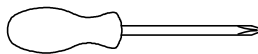

<p>1</p>  <p>Screws $\frac{1}{4}$" x 40 mm -3pcs Vis</p>	<p>2</p>  <p>Wood Screws M4 x 40 mm -25pcs Les vis à bois</p>	<p>3</p>  <p>Bolts $\frac{1}{4}$" x 35 mm -2pcs Boulon</p>
<p>4</p>  <p>Bolts $\frac{1}{4}$" x 70 mm -5pcs Boulon</p>	<p>5</p>  <p>Bolts $\frac{1}{4}$" x 100 mm - 22pcs Boulon</p>	<p>6</p>  <p>$\frac{1}{4}$" x 13 mm Horizontal-Hole bolts - 24pcs Boulons à trou horizontal</p>
<p>7</p>  <p>Wood dowel $\varnothing 8$ x 30 mm -35pcs Cheville en bois</p>	<p>8</p>  <p>Wood Screws M4 x 30 mm -40pcs Les vis à bois</p>	<p>9</p>  <p>Wood Screws M4 x 20 mm -8pcs Les vis à bois</p>
<p>10</p>  <p>Handle 4pcs Poignée</p>	<p>11</p>  <p>Allen Key - 1pc Clé Allen</p>	



Assembly Tools Required (Not Included)

Outils d'assemblage requis (Non Inclus)

STEP 1:
Étape 1:

7	2
	
4(pcs)	2(pcs)

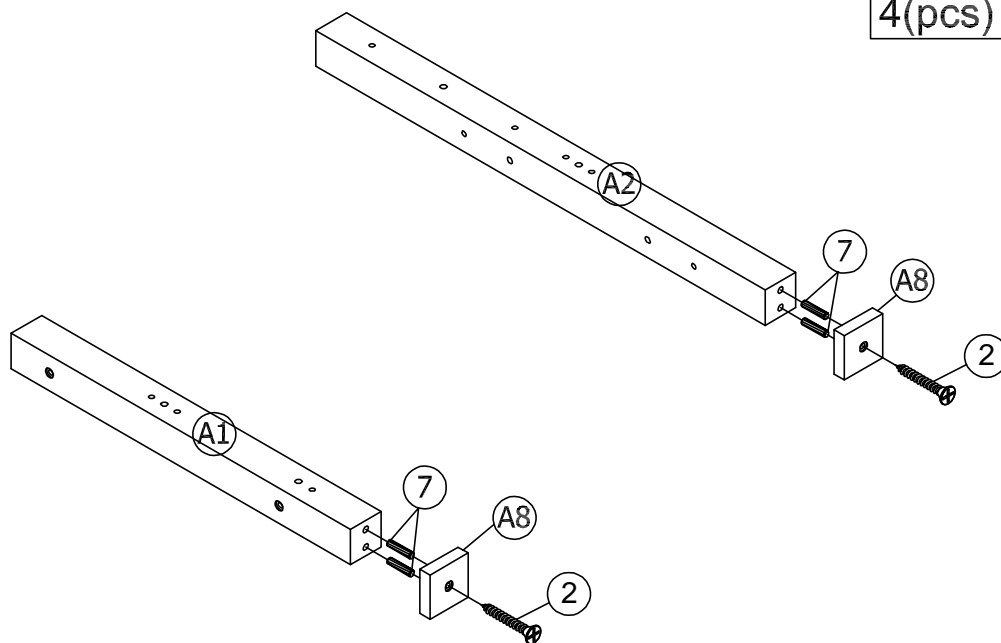

STEP 2:
Étape 2:

2

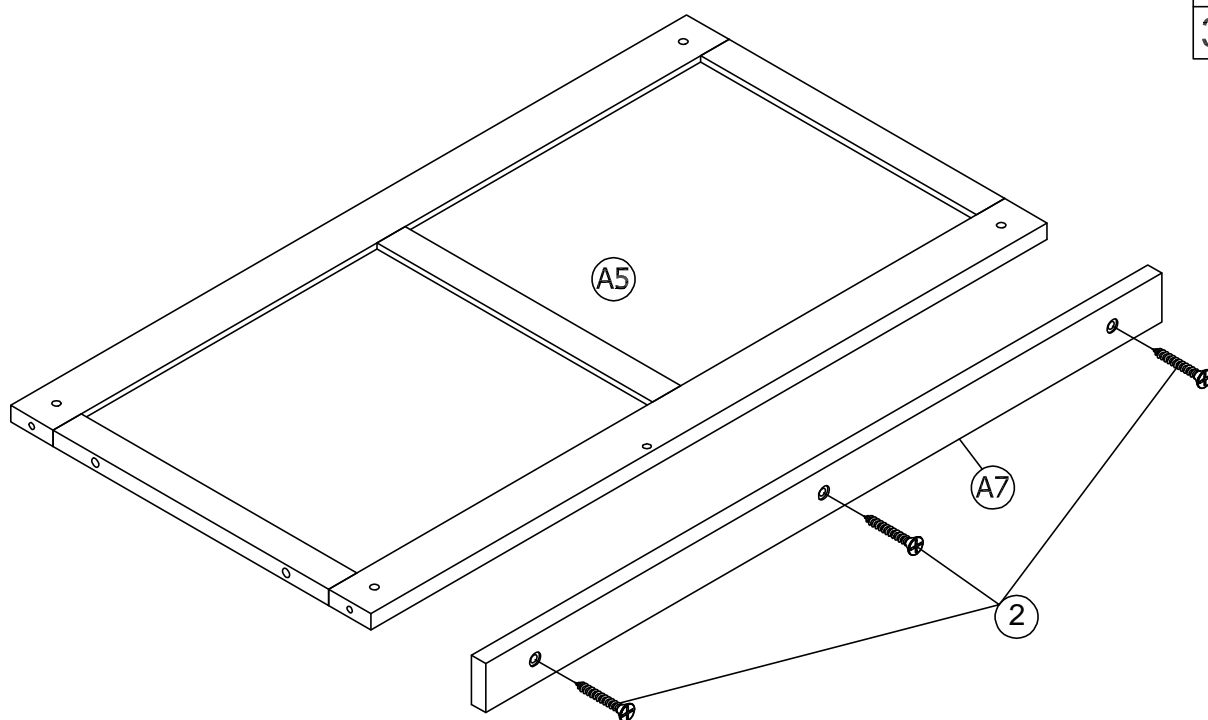
3(pcs)

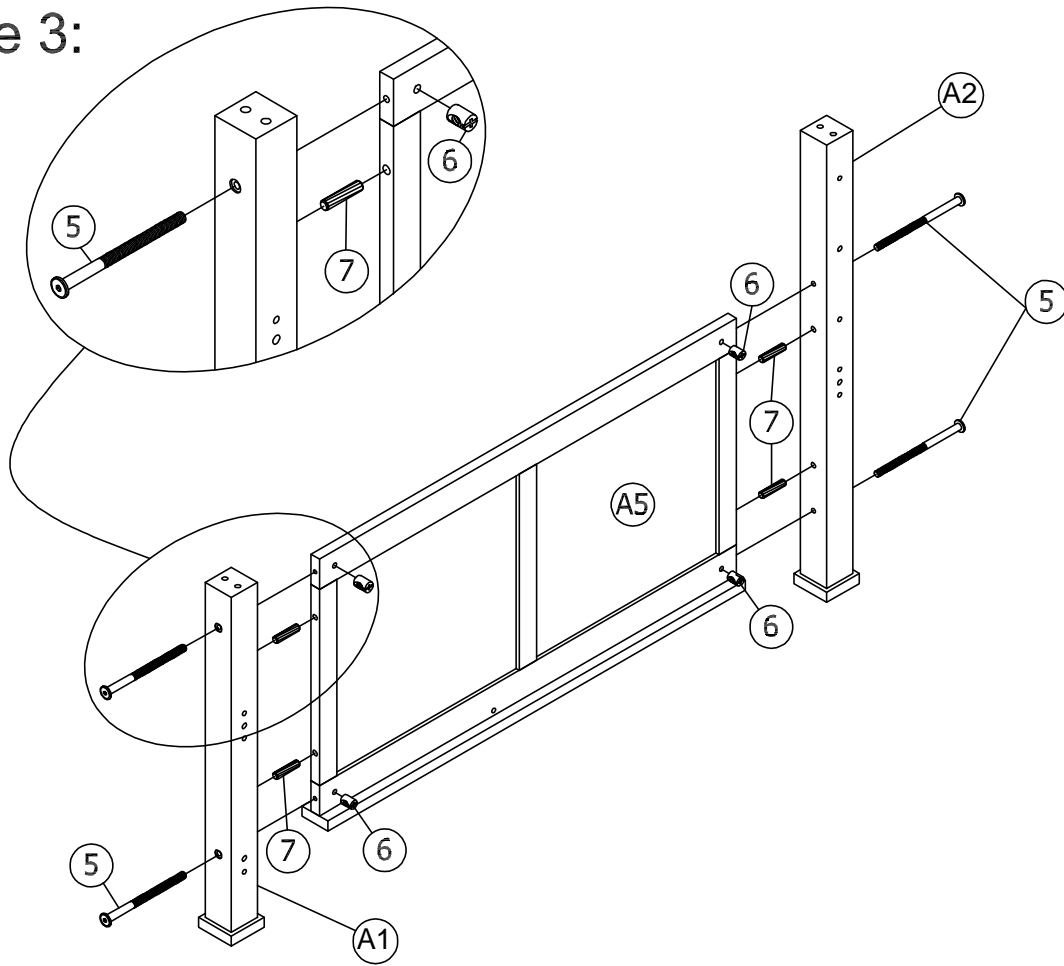

STEP 3:

Étape 3:



5	
4(pcs)	
6	
4(pcs)	
7	
4(pcs)	

STEP 4:

Étape 4:

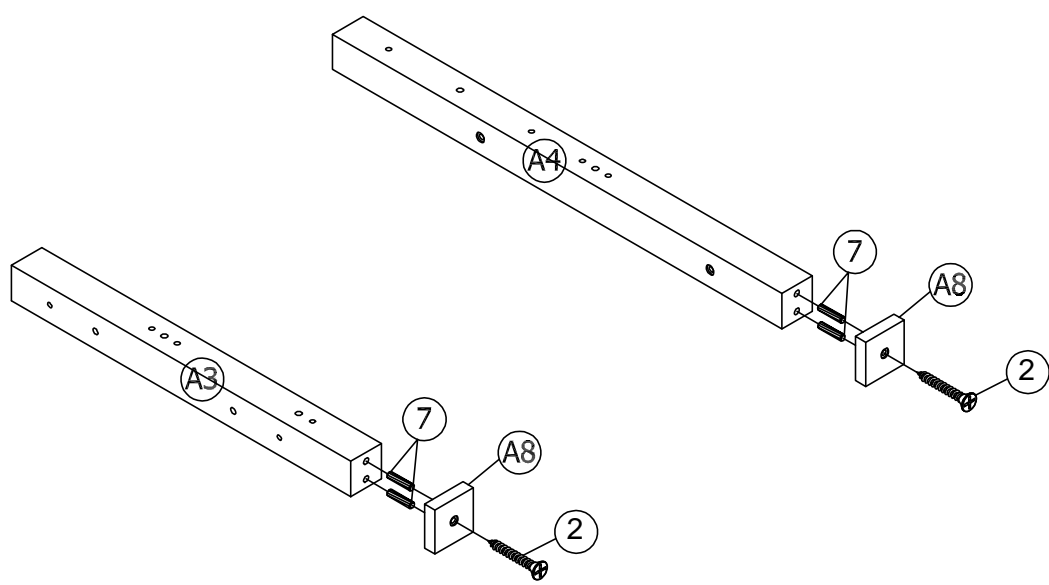

7		2	
4(pcs)		2(pcs)	

STEP 5:

Étape 5:

2



3(pcs)

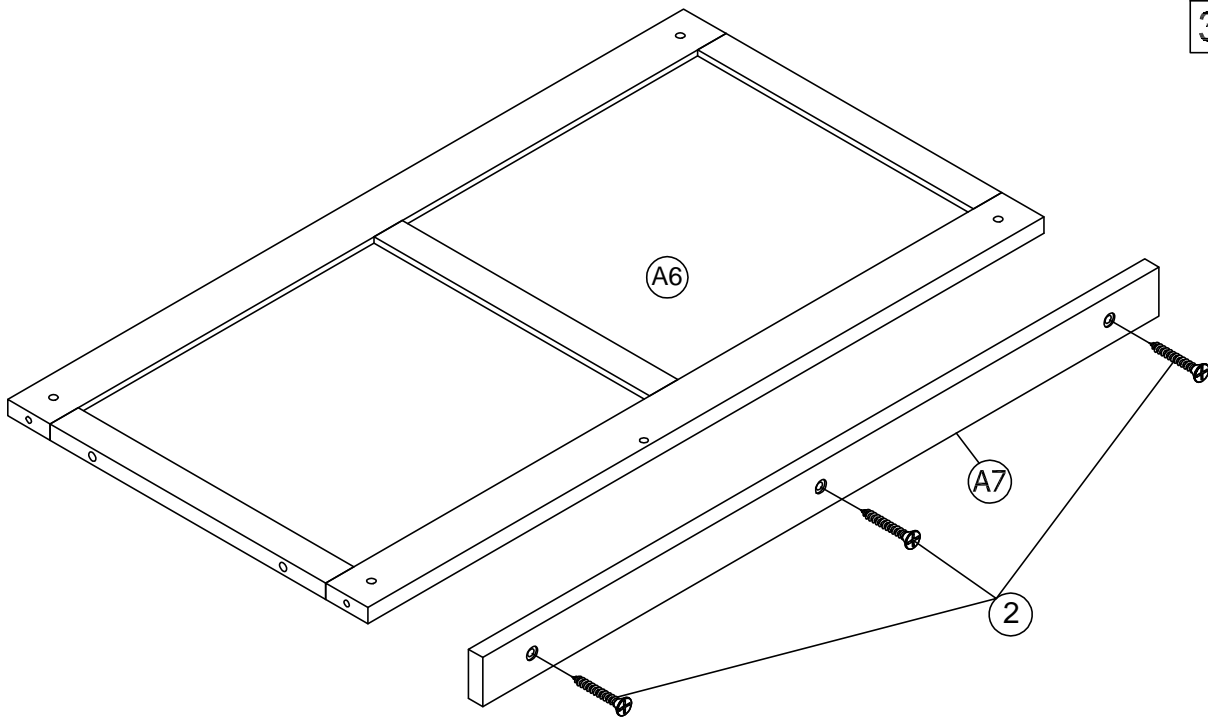

STEP 6:

Étape 6:

5

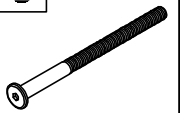

4(pcs)

6



4(pcs)

7



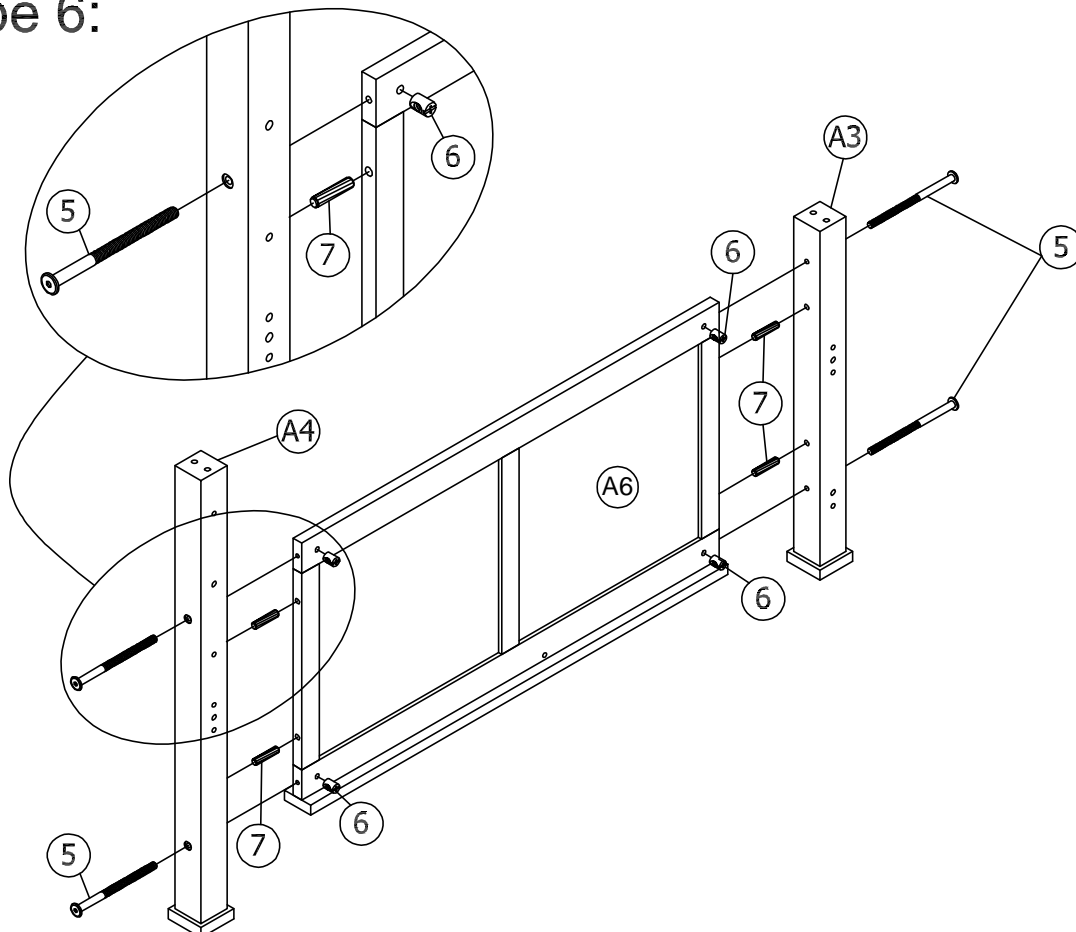

4(pcs)



STEP 7:

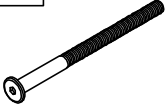

Étape 7:

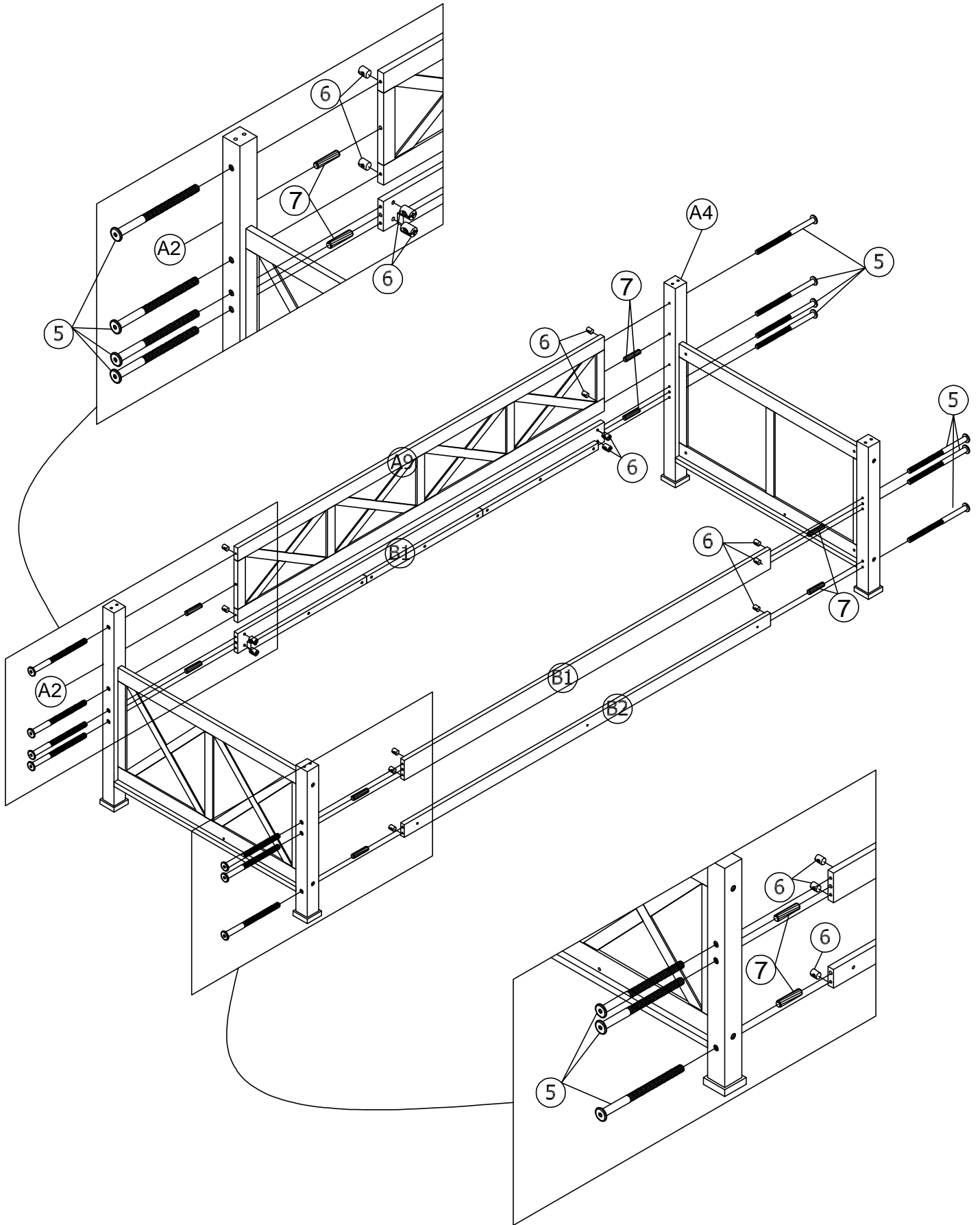
7	6	5
		
8(pcs)	14(pcs)	14(pcs)



STEP 8:

Étape 8:

6		4	
2(pcs)		2(pcs)	

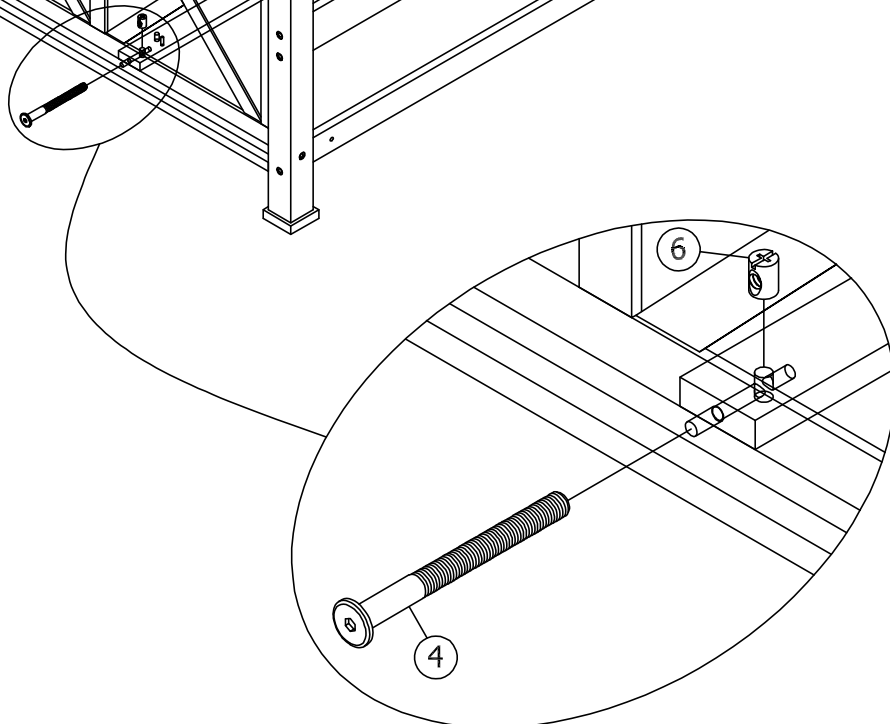
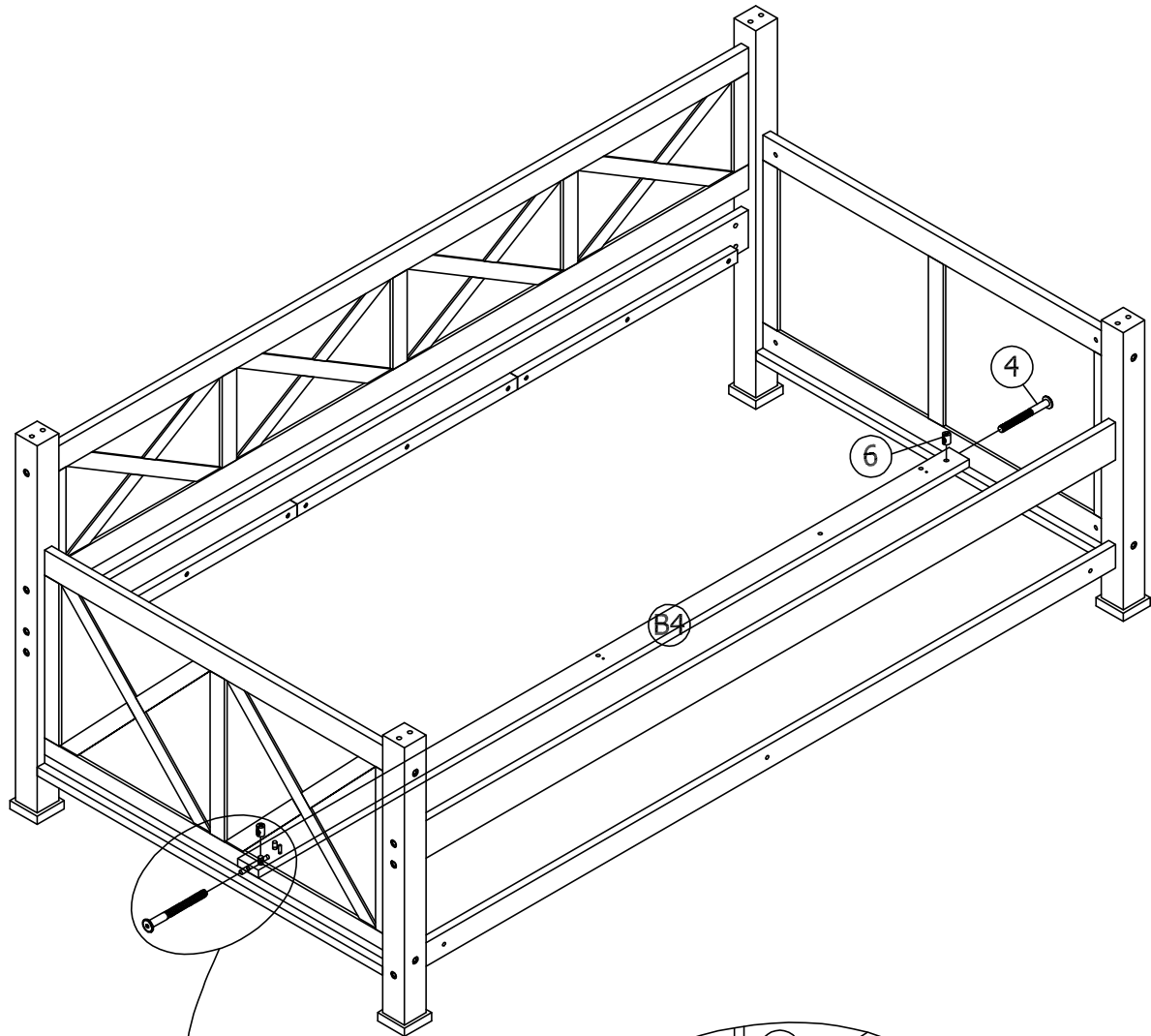

STEP 9:

Étape 9:

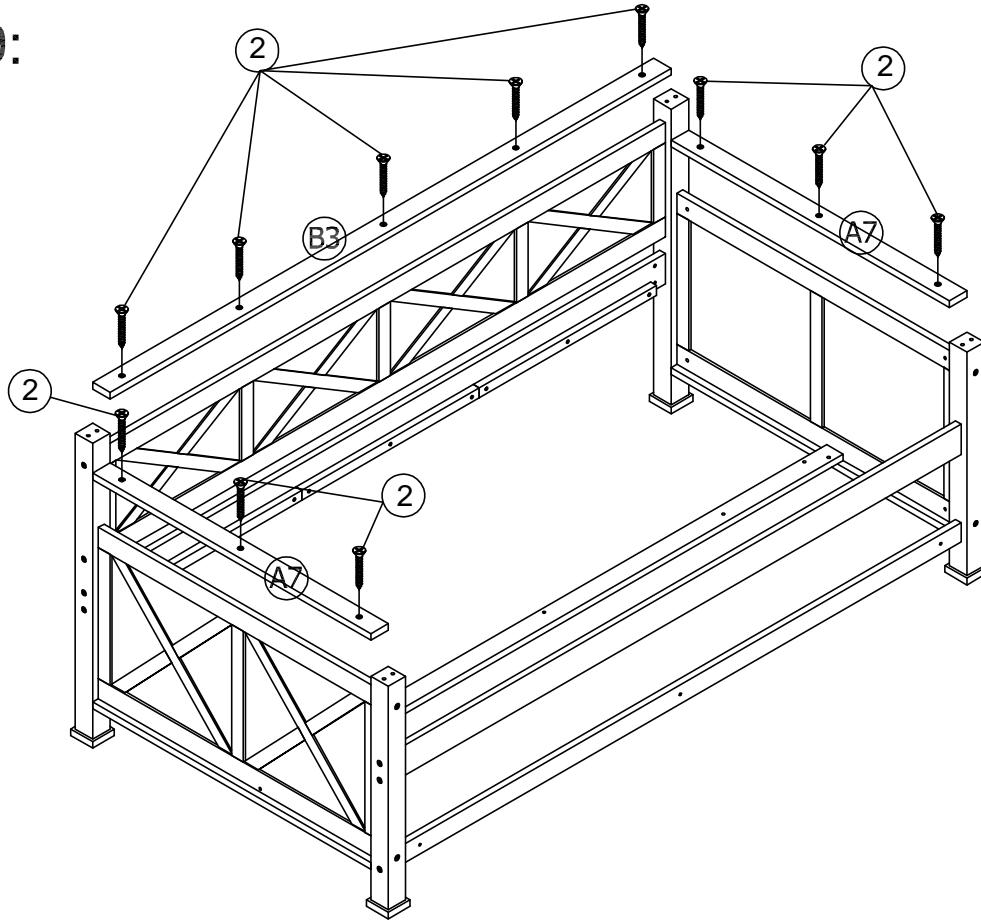



2	
11(pcs)	

STEP 10:

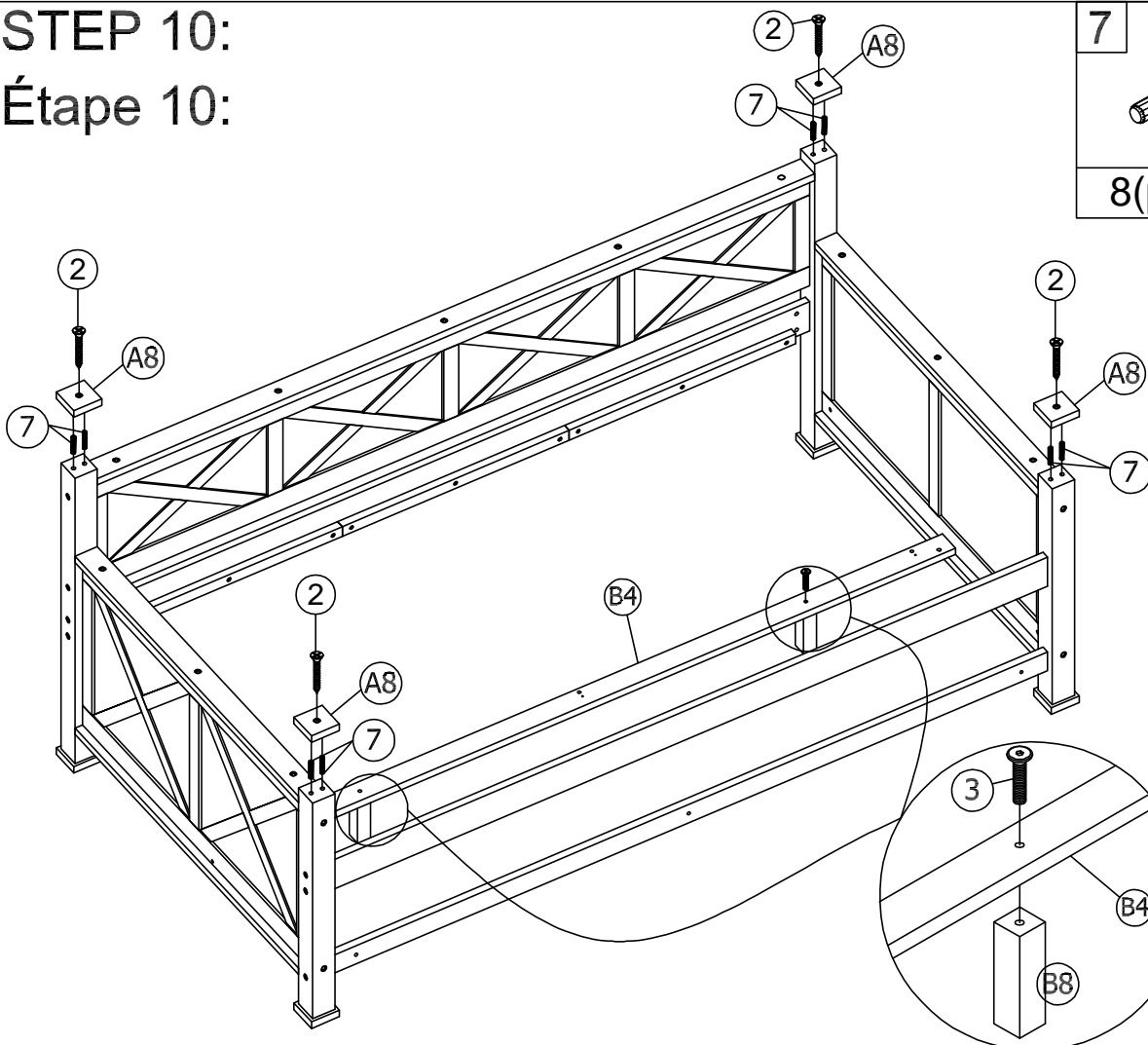

Étape 10:



7		2	
8(pcs)		4(pcs)	
		3	
		2(pcs)	

STEP 11:

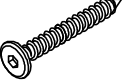

Étape 11:

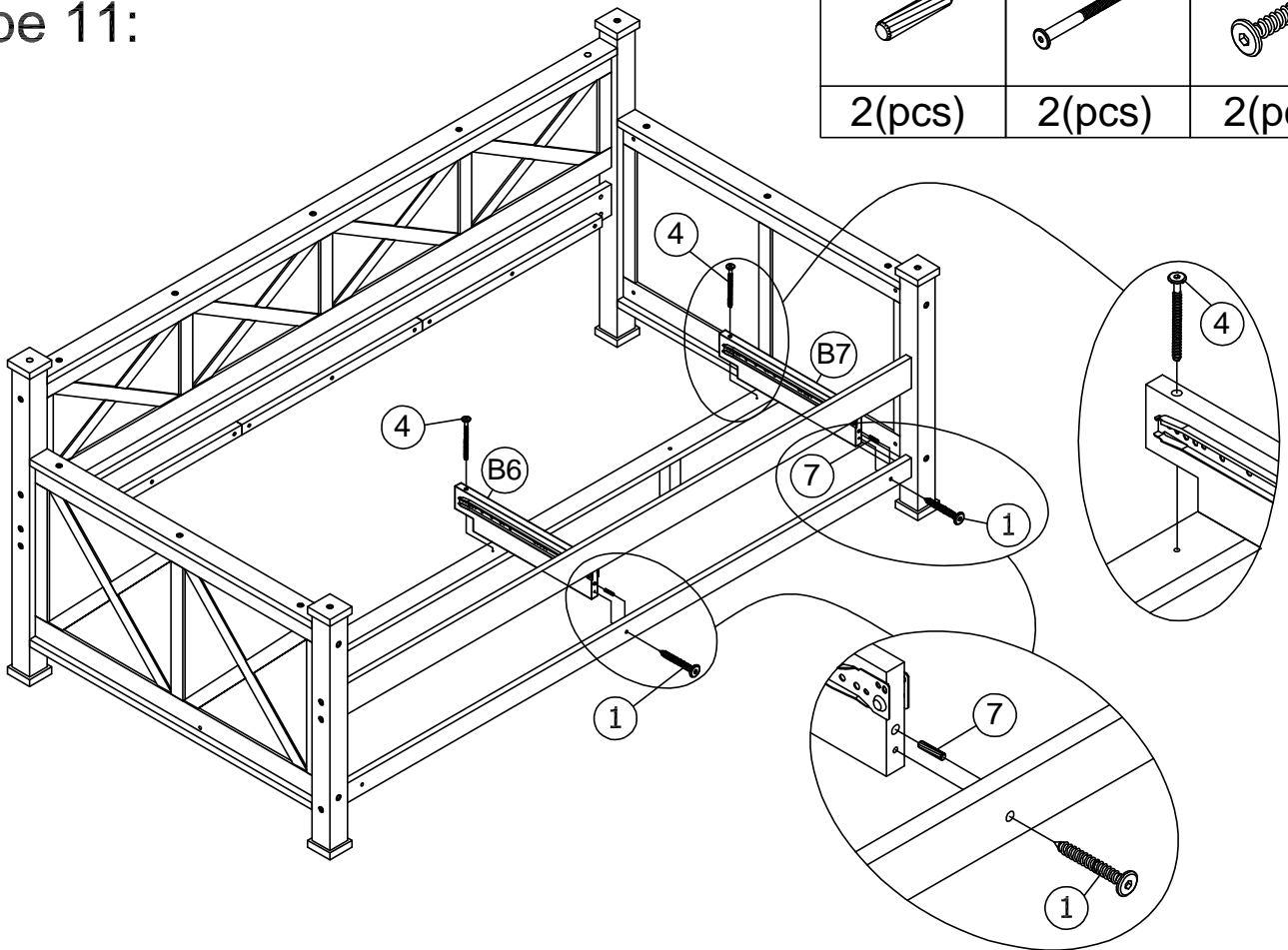
7	4	1
		
2(pcs)	2(pcs)	2(pcs)



STEP 12:

Étape 12:

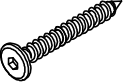
7	4	1
		
1(pc)	1(pc)	1(pc)

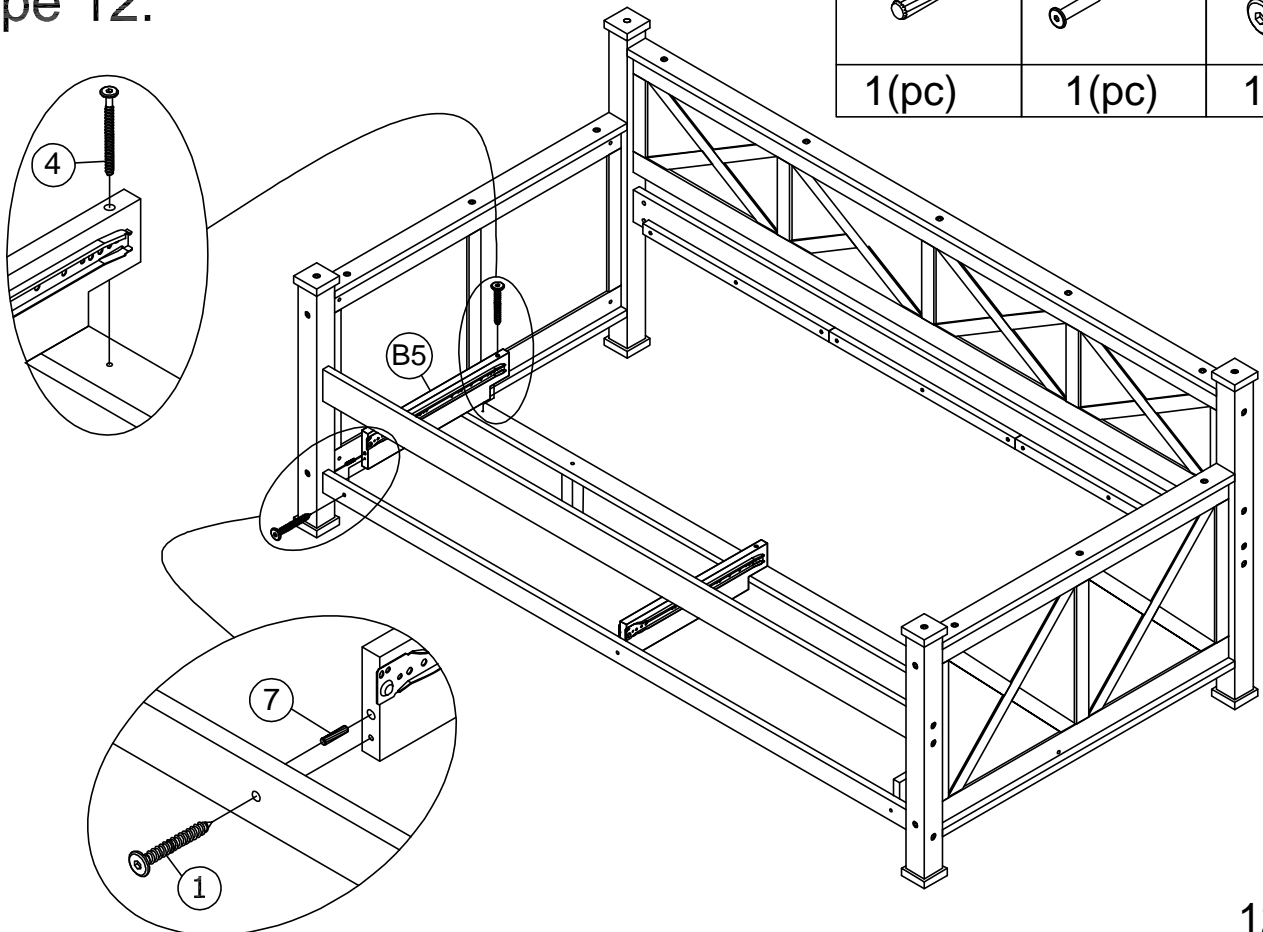

STEP 13:

Étape 13:

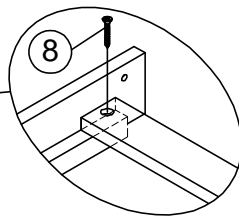
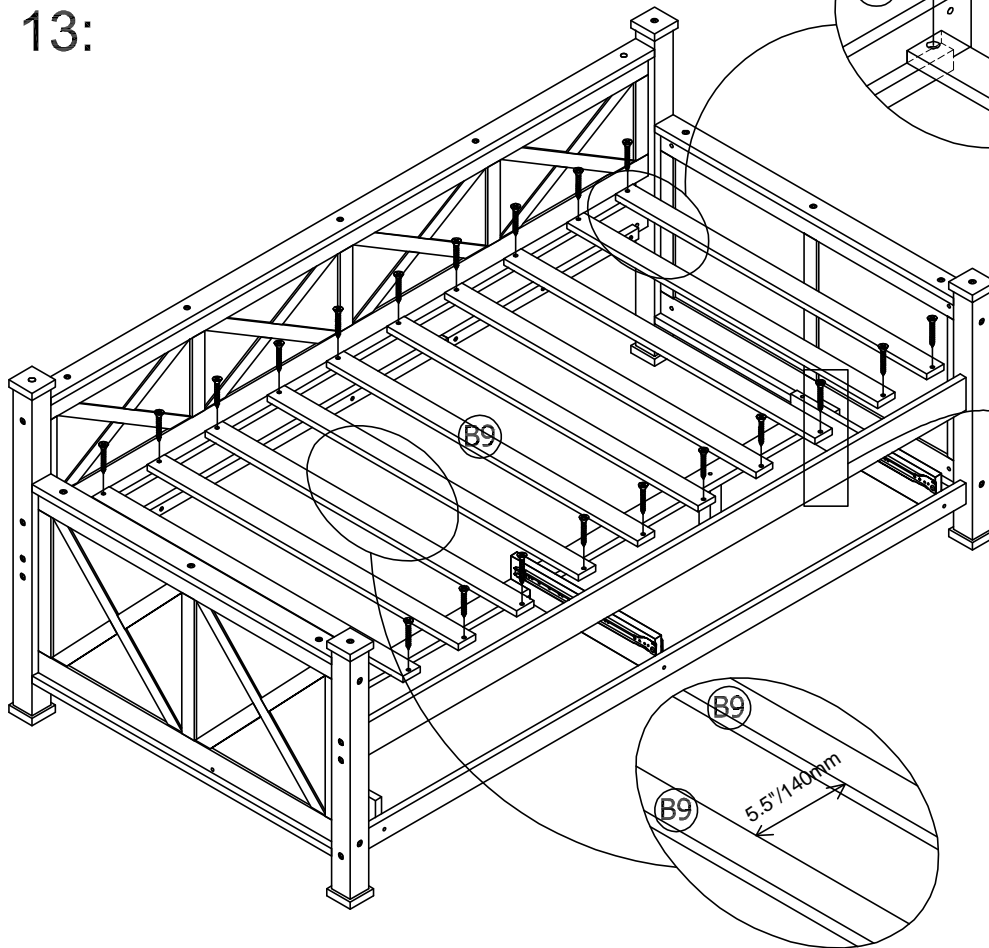

8



20(pcs)

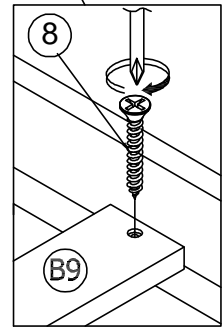

STEP 14:

Étape 14:

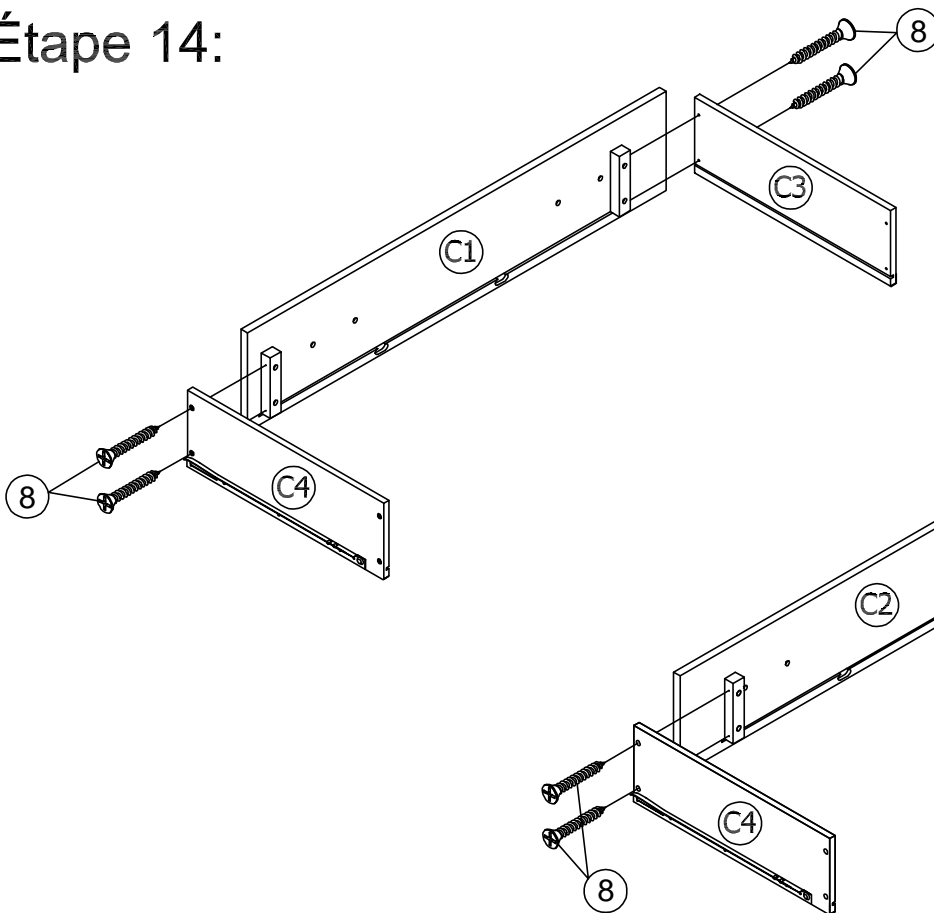

8



8(pcs)

STEP 15:

Étape 15:

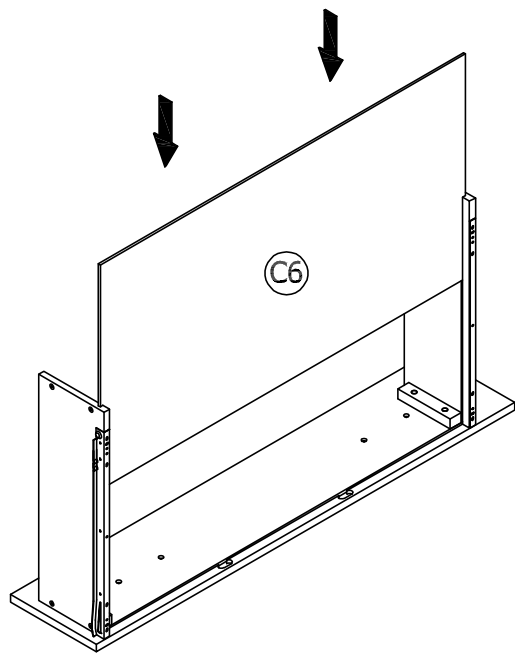
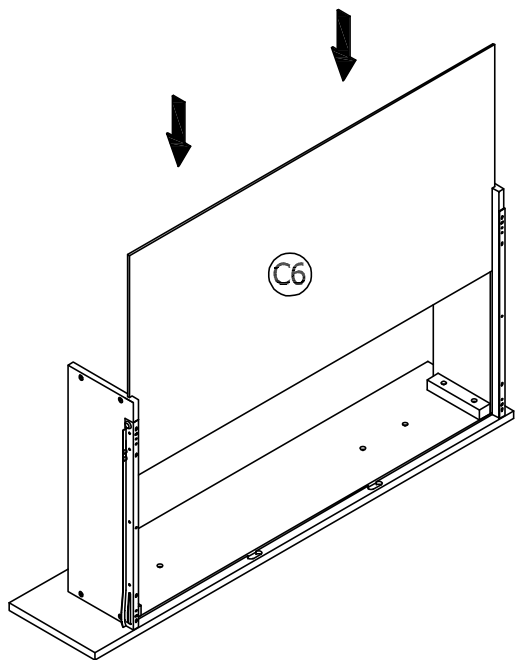

STEP 16:

Étape 16:

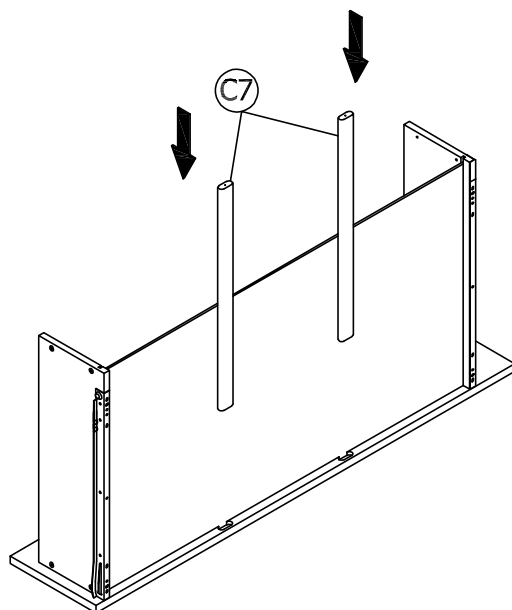
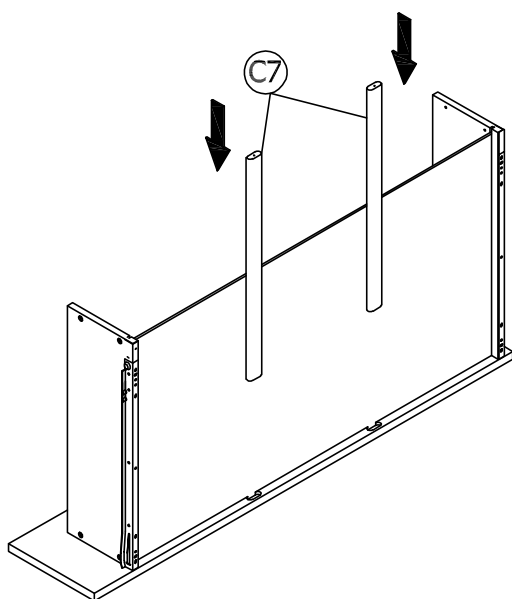

STEP 17:

Étape 17:

8



12(pcs)

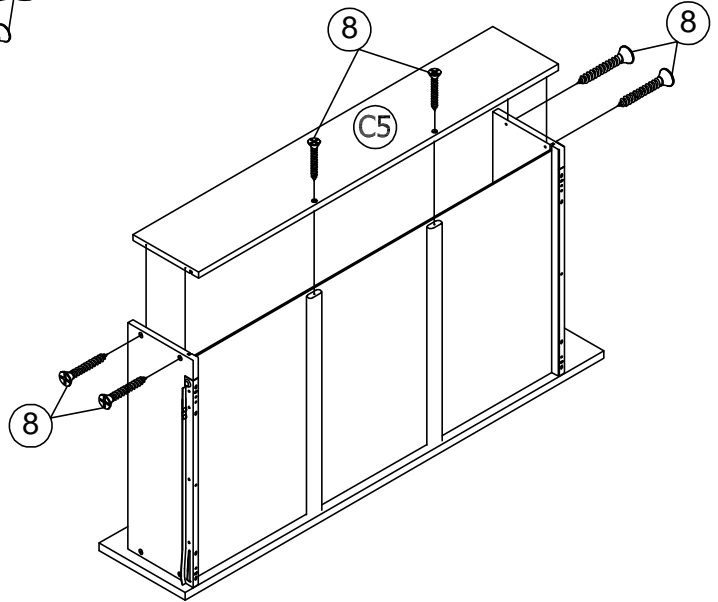
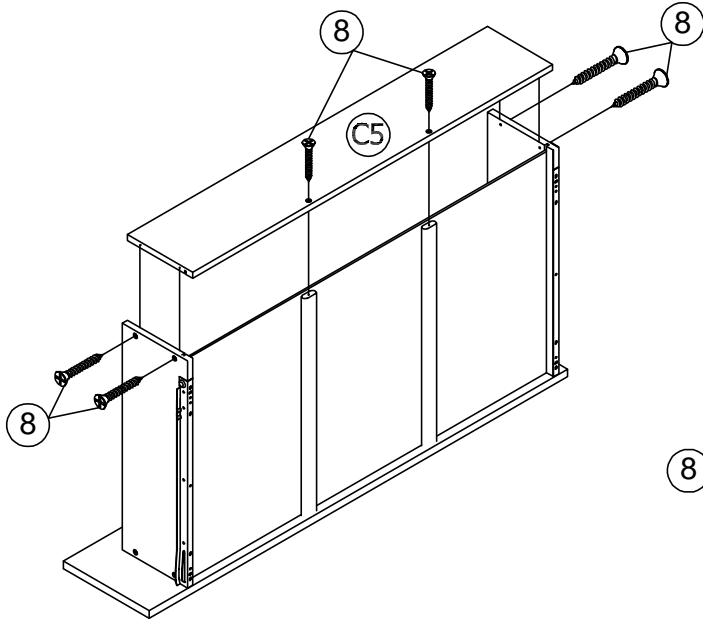

STEP 18:

Étape 18:

10

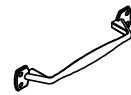

4(pcs)

9

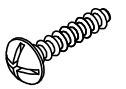

8(pcs)

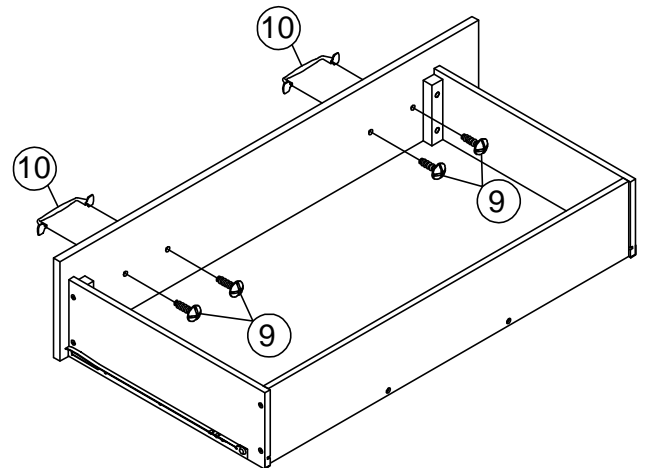
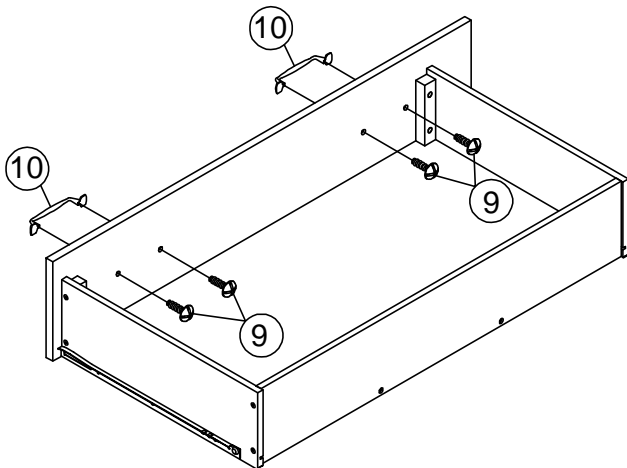

STEP 19:

Étape 19:

