

ASSEMBLY INSTRUCTION (WF317683 / WF317686)

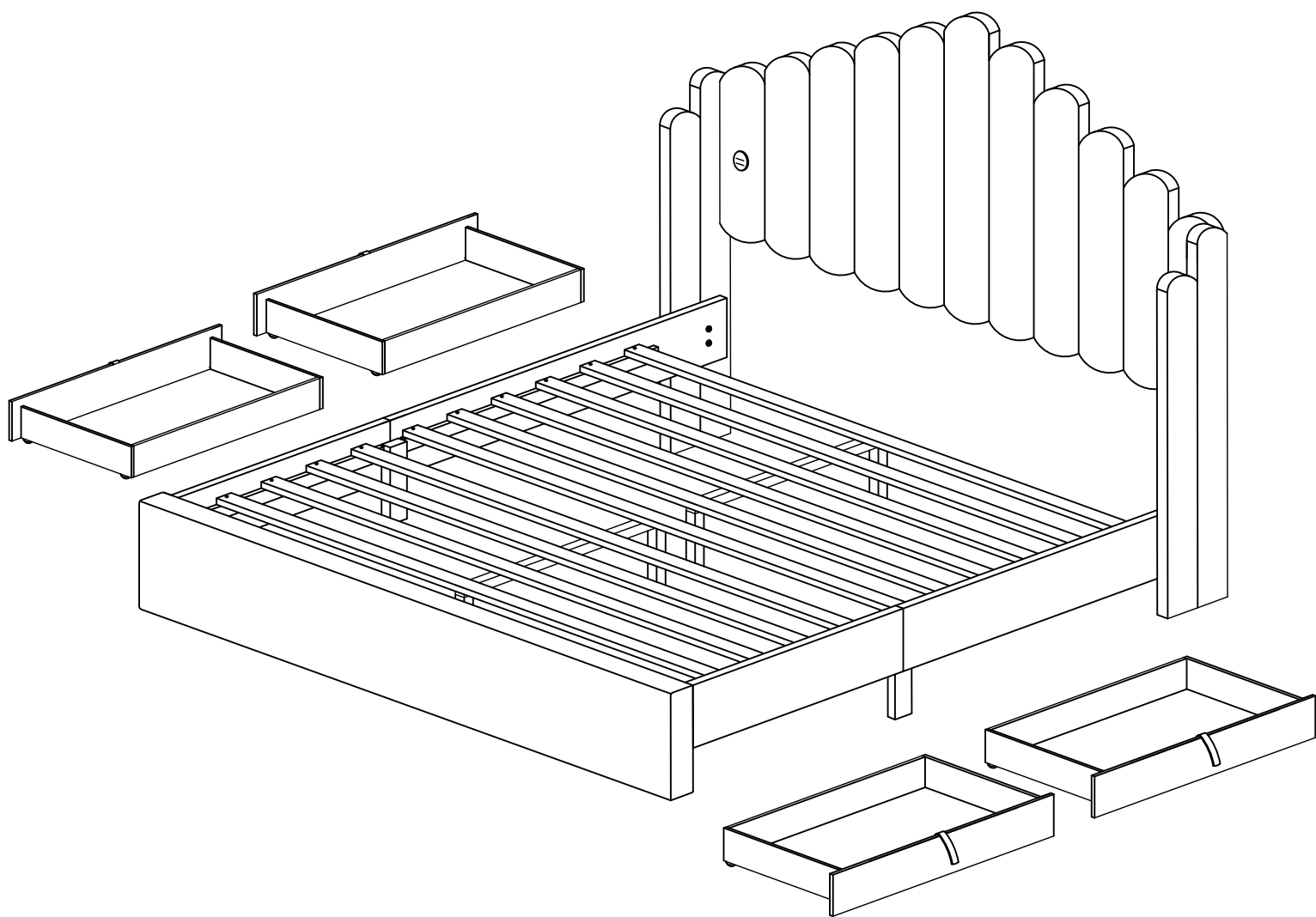

ASSEMBLY INSTRUCTION (WF317683 / WF317686)

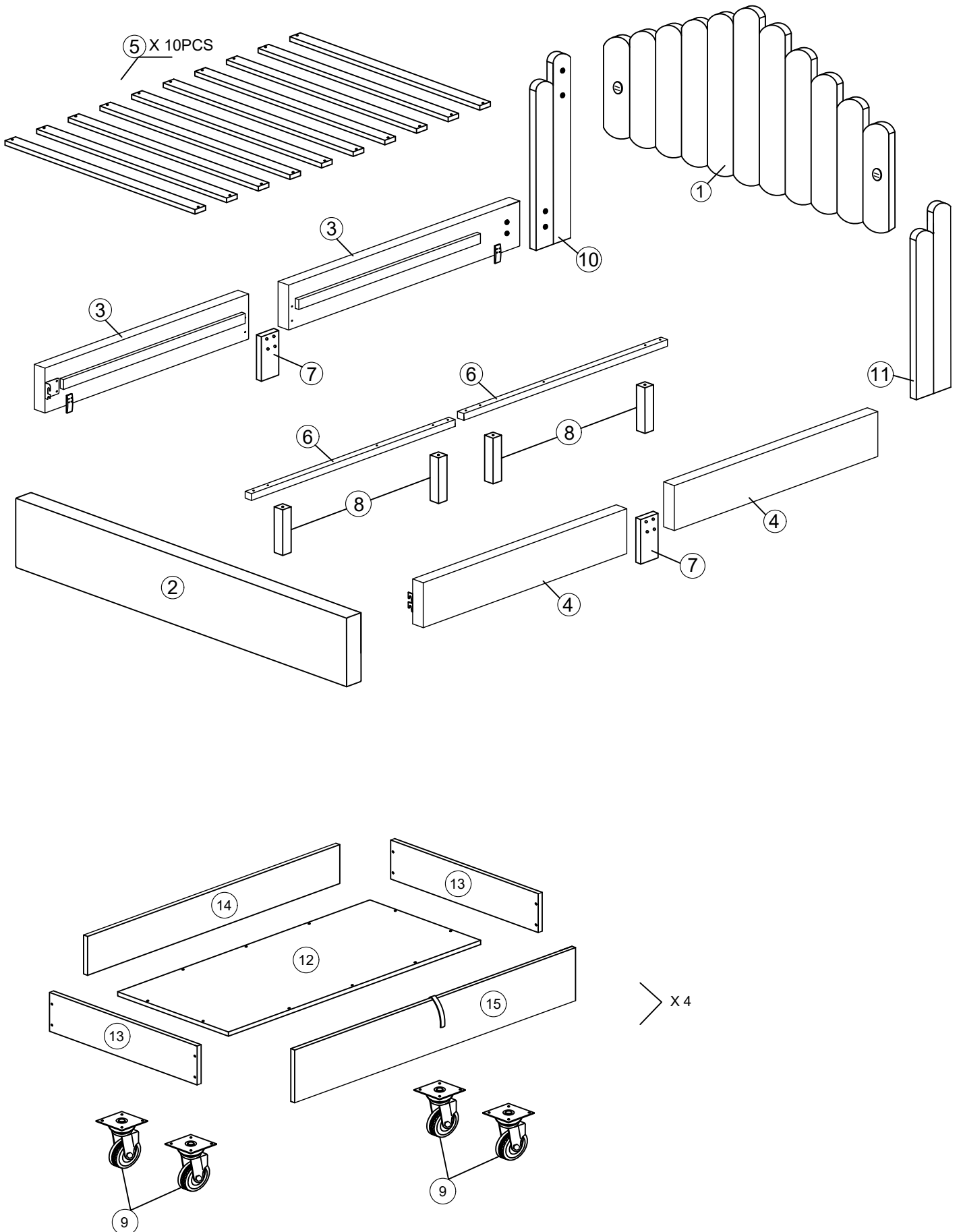

Part List (Box 1 - WF317683)

1

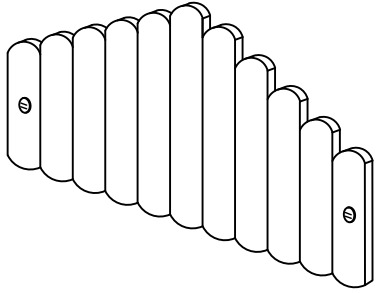

Headboard 1pc

The image shows a single headboard component consisting of a series of vertical slats of varying heights, arranged in a slightly curved pattern. Two circular fasteners are visible on the ends.

2

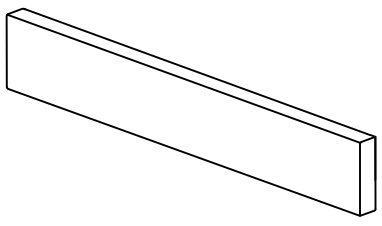

Footboard 1pc

The image shows a single, long, rectangular footboard component.

3

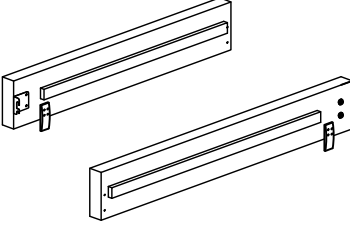

SidePanel (L) 2pcs

The image shows two side panel components for the left side, each featuring a long horizontal slot and a small protrusion on the side.

4

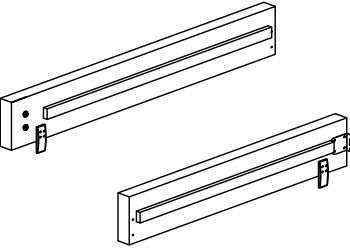

SidePanel (R) 2pcs

The image shows two side panel components for the right side, similar to the left side panels but with a different protrusion design.

5

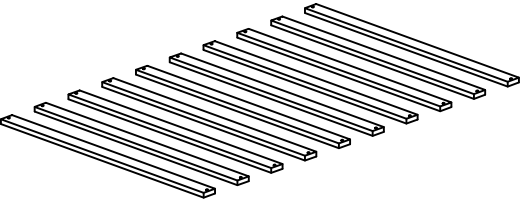

LVL Slats 10pcs

The image shows ten long, thin, rectangular LVL slats arranged in a slightly curved pattern.

6

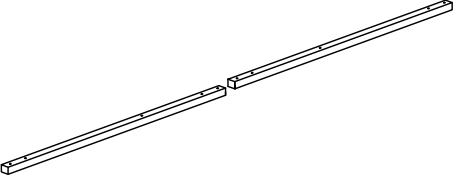

Center Wood 2pcs

The image shows two long, thin, rectangular center wood pieces, one of which is shown with a small notch or joint.

7

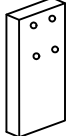

Side Panel
Center Leg 2pcs

The image shows two side panel center leg components, each a vertical rectangular piece with two circular holes.

8

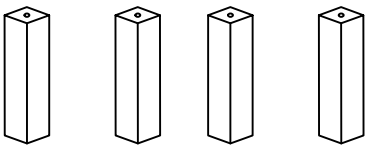

Center Legs 4pcs

The image shows four vertical rectangular center leg components.

9



CASTER NO LOCK
16pcs

The image shows a single castor wheel with a square mounting plate and a locking mechanism.

Part List (Box 2 - WF317686)

10

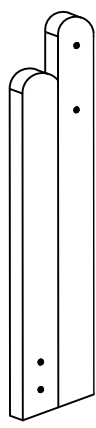

Side Panel (L) 1pc

11

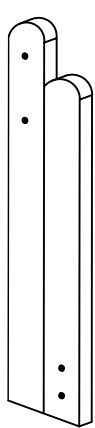

Side Panel (R) 1pc

12

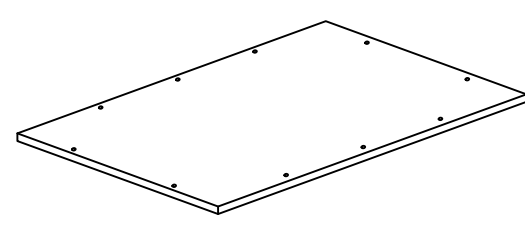

Drawer Bottom Panel 4pcs

13

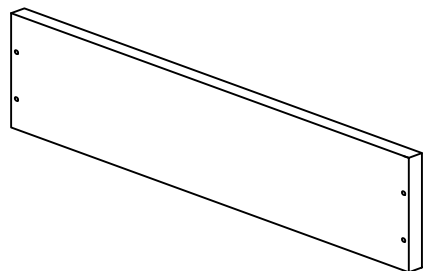

Drawer Side Panel (L / R) 8pcs

14

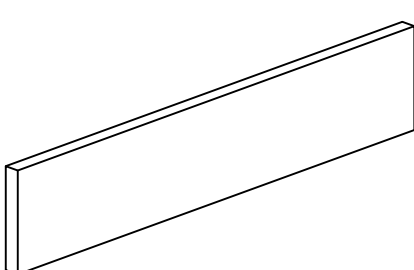

Drawer Back Panel 4pcs

15

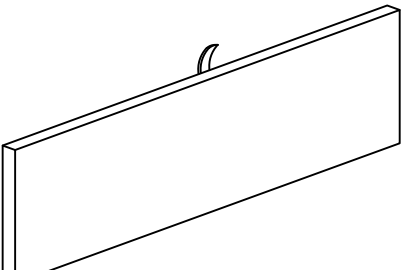

Drawer Front Panel 4pcs

Hardware List (Box 1 - WF317683)

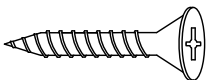
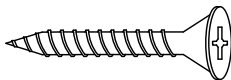
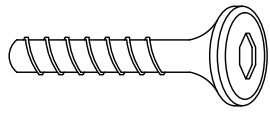
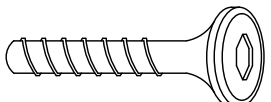
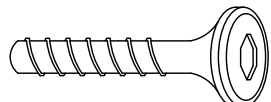
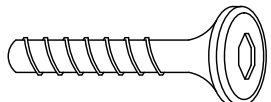
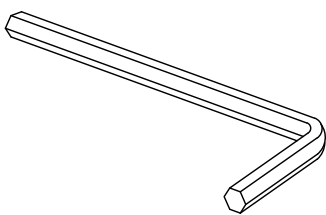
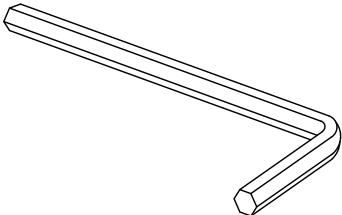
<p>A</p>  <p>M4 X 16 MM Chipboard Screw 64pcs</p>	<p>B</p>  <p>M4 X 32 MM Chipboard Screw 92pcs</p>	<p>C</p>  <p>M6 X 25 MM JCBC Screw 8 pcs</p>
<p>D</p>  <p>M6 X 30 MM JCBC Screw 4 pcs</p>	<p>E</p>  <p>M6 X 45 MM JCBC Screw 10pcs</p>	<p>F</p>  <p>M8 X 25 MM JCBB Screw 4pcs</p>
<p>G</p>  <p>M4 Allen Key 1 pc</p>	<p>H</p>  <p>M5 Allen Key 1 pc</p>	

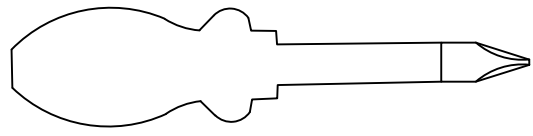

ASSEMBLY TOOLS REQUIRED (NOT INCLUDED)

ASSEMBLY INSTRUCTION

STEP 1

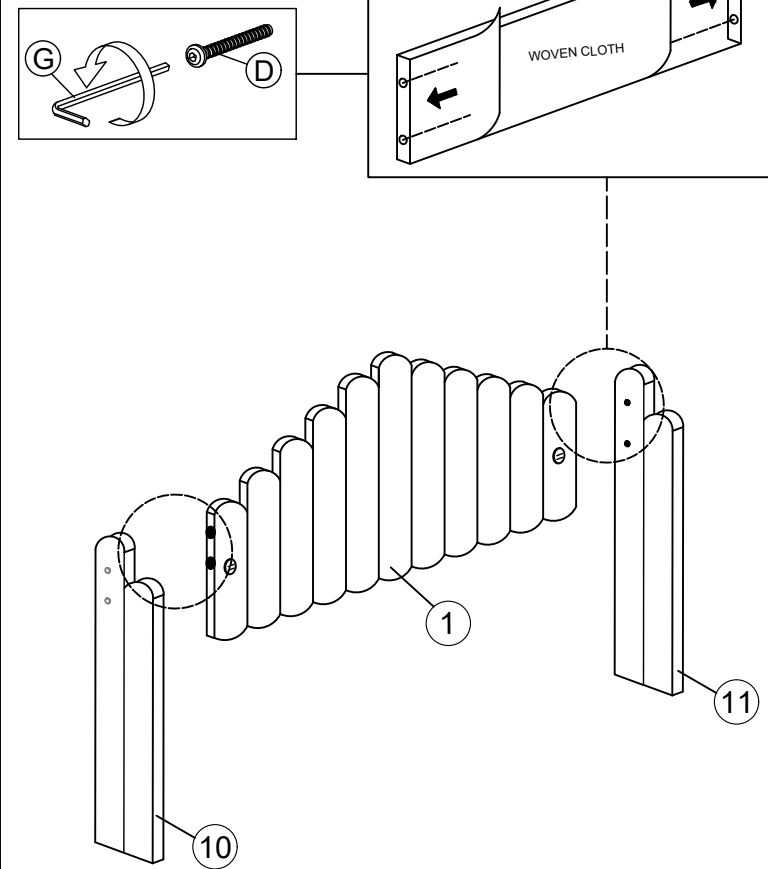

STEP 2

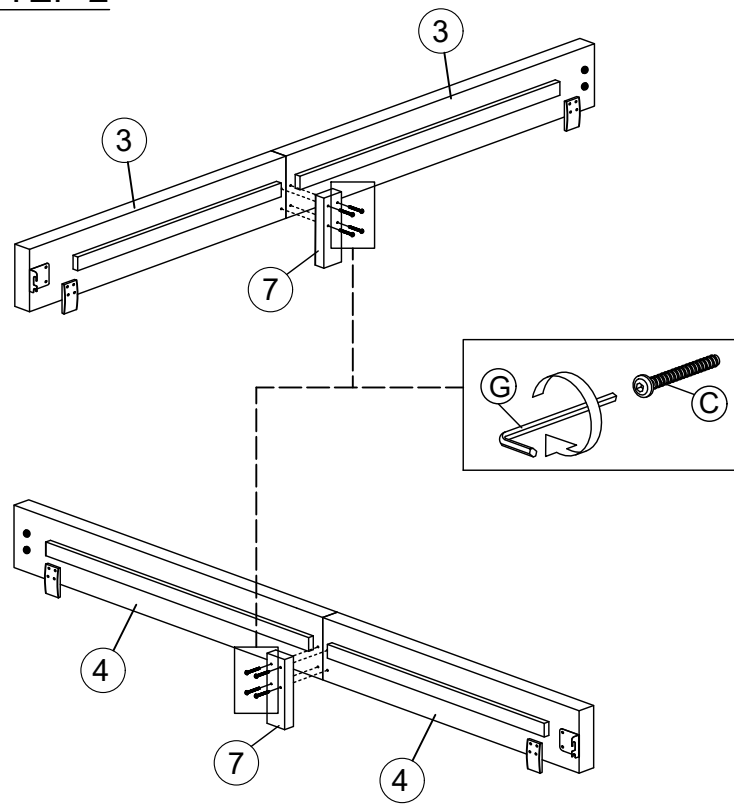

STEP 3

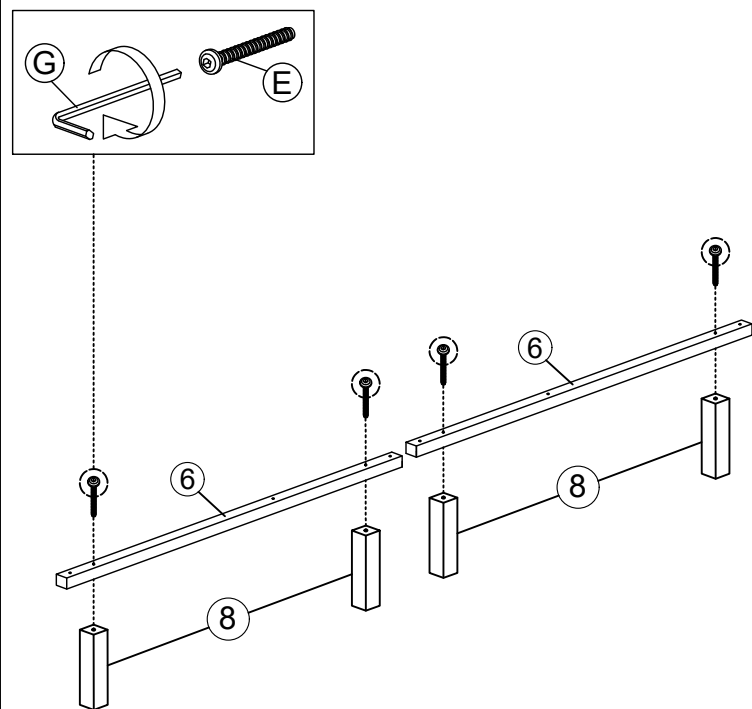

STEP 4

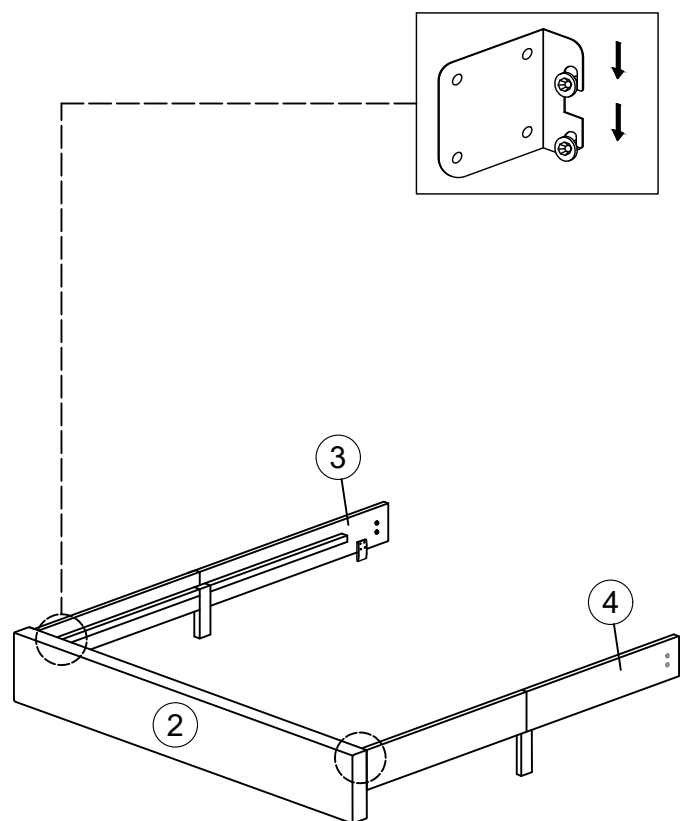

ASSEMBLY INSTRUCTION

STEP 5

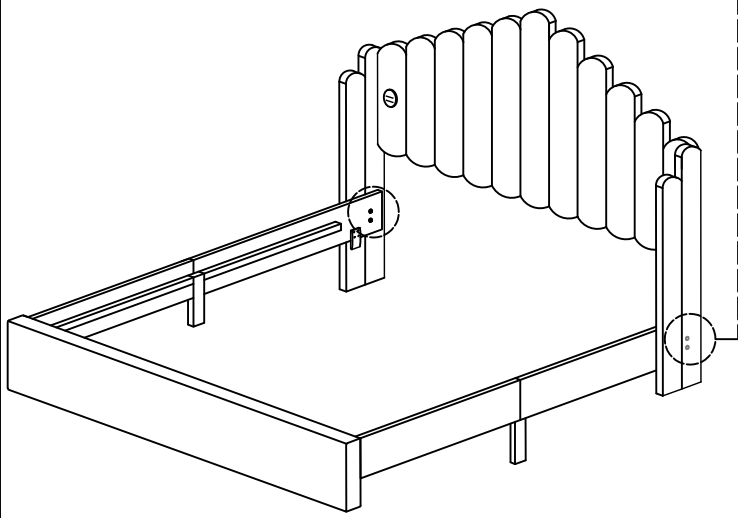
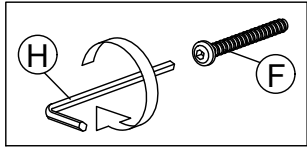

STEP 6

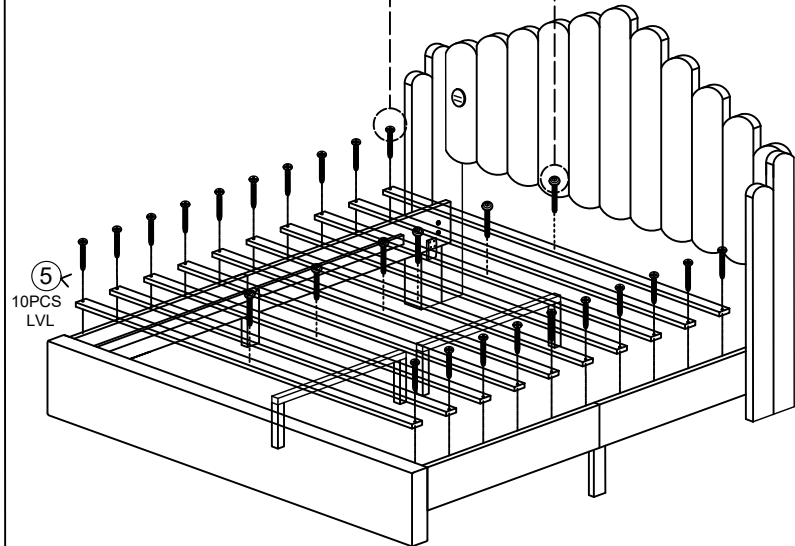
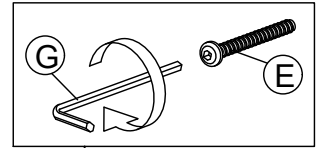
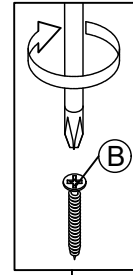

COMPLETE

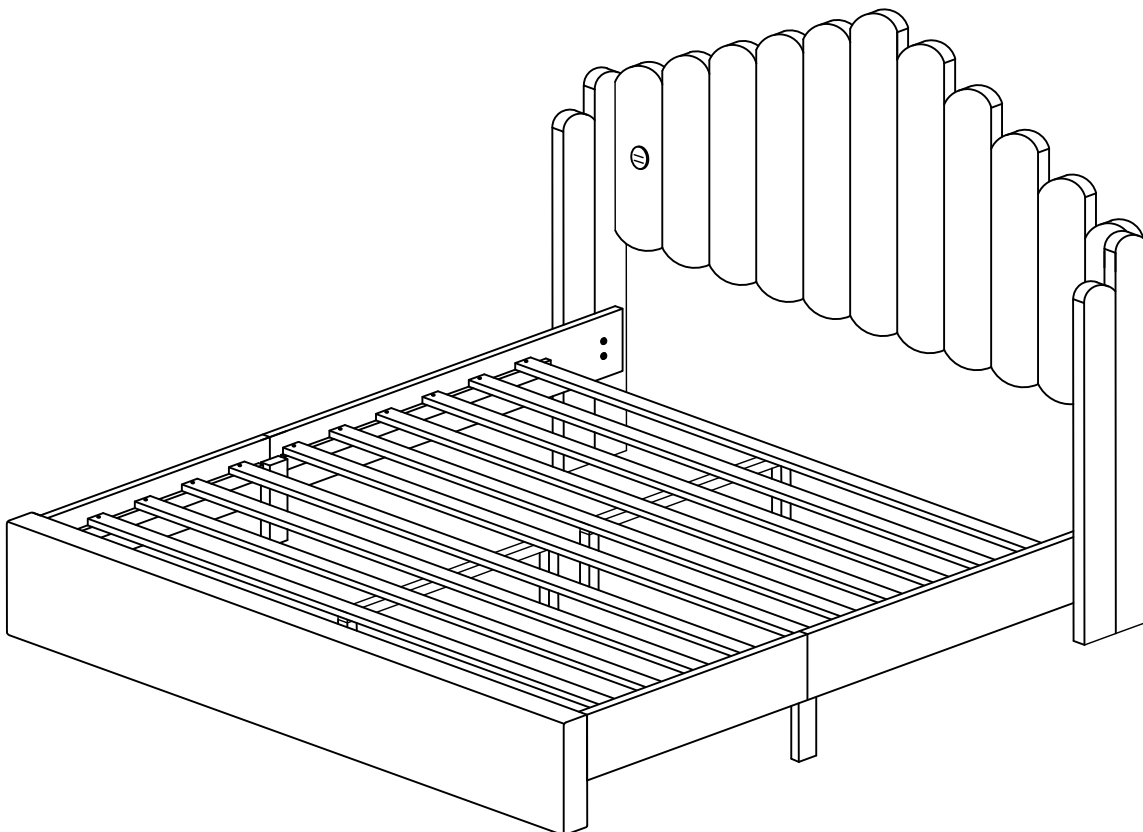

ASSEMBLY INSTRUCTION

STEP 7

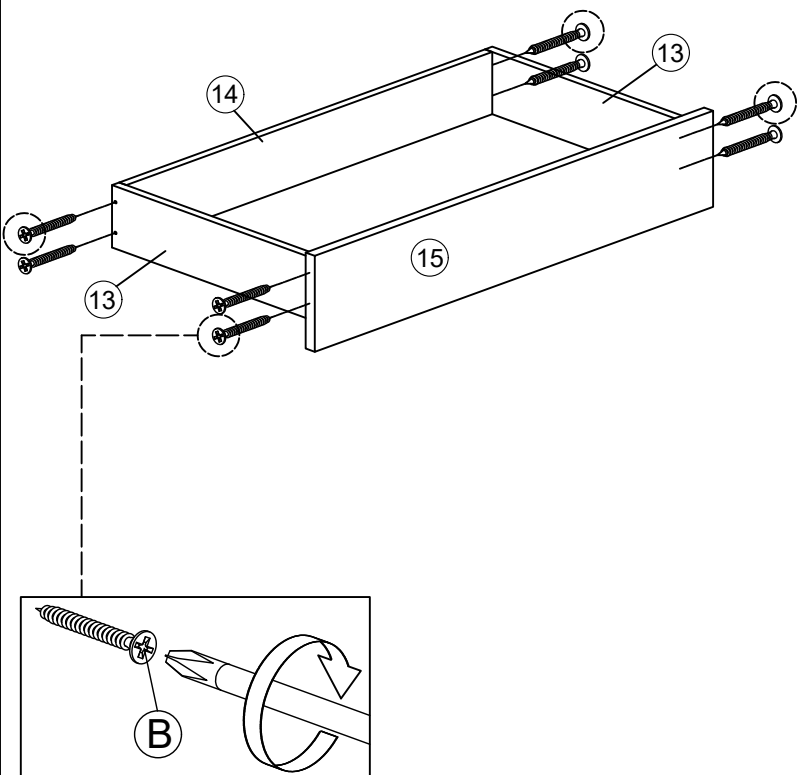

STEP 8

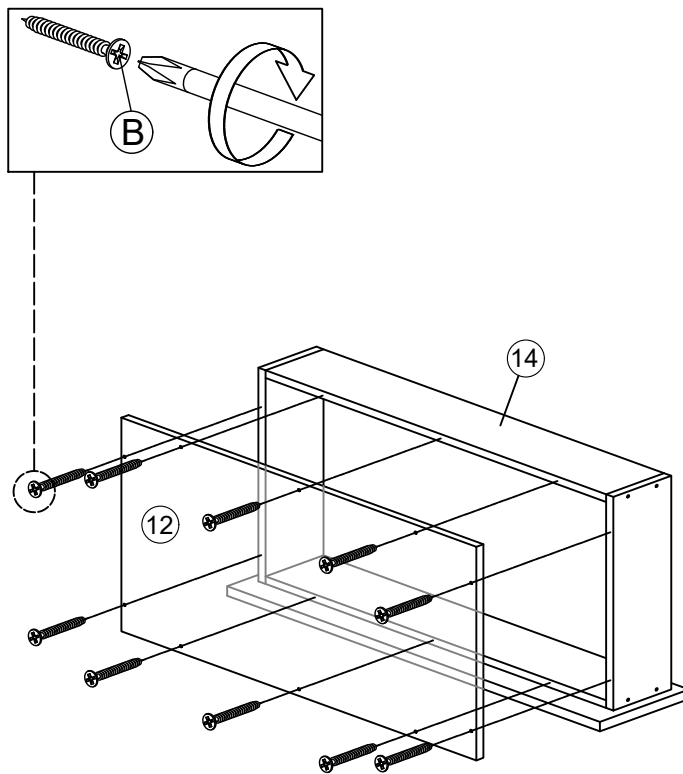

STEP 9

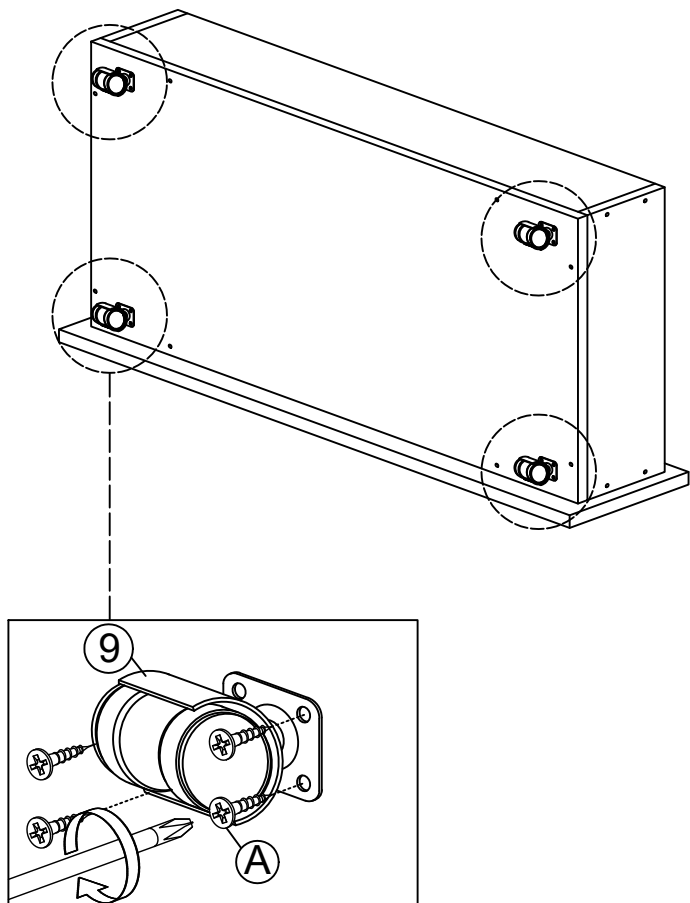

COMPLETE

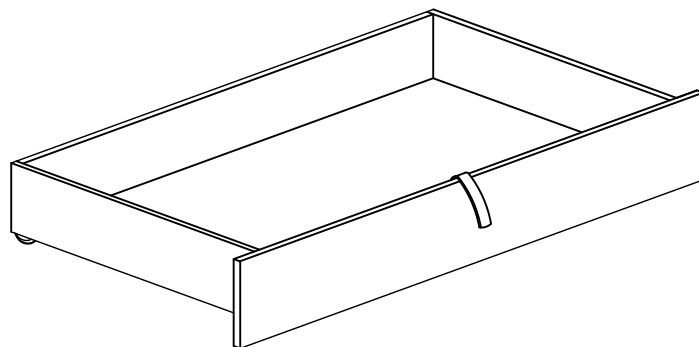

FULLY COMPLETED ASSEMBLY

