

Coffe Table Wide

assembly guide

introduction



Before starting, please check all components and accessories according to the provided list. If you purchased more than one product, to prevent confusion, be sure that you completed the first product, then start the next one. Please make sure that you select correct numbered part and use specific connector to assemble. We do not recommend any modification or rotation in assembly. Please follow the manual carefully.

Furniture parts are going to several manufacturing procedures. During this process, parts can have little dust or marks. Please clean the parts with damp cloth before assembly to get the best result. Usual cleaning would be suffice.

Valued Customer,

We design and carefully manufacture our products for our customers, We wish that our customers to have fun while they are doing their new furniture

The product you just purchased was subjected to all sorts of tests and controls before sending out to you.

Hope you enjoy your new furniture!!!



Do not use your furniture for out of purposes.

Please do not expose your furniture with excessive heat, cold and humidity because product can be affected negatively.

before you start

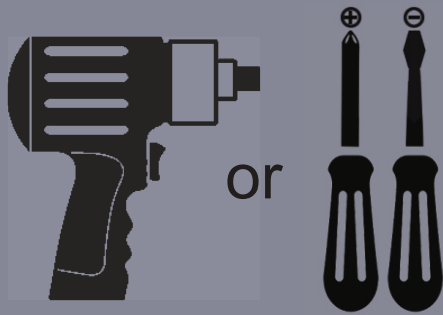

Get required installation tools prepared.

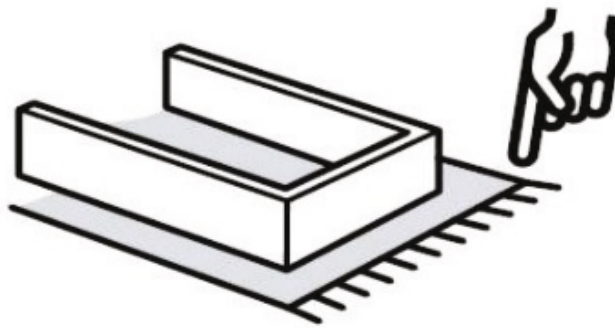
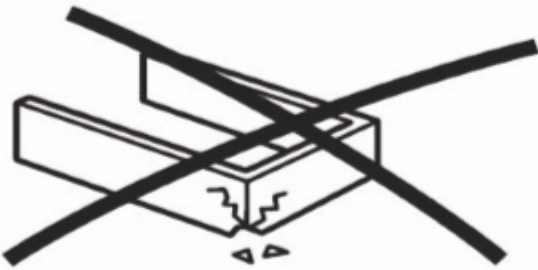

Do not install the product on rough surfaces.



Get help from someone else!

getting familiar with the main components

*Minifix is the main connection component used in
Before starting, please check
the below figures

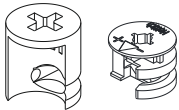

MINIFIX
HEAD

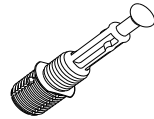

MINIFIX
SCREW



DOWEL

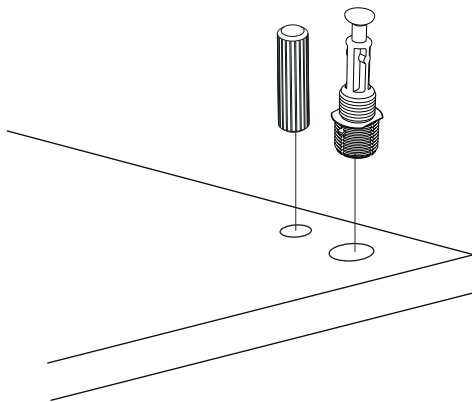

*Please notice that there is an small arrow on A02 (minifix head). This arrow should show the direction of upper hole.

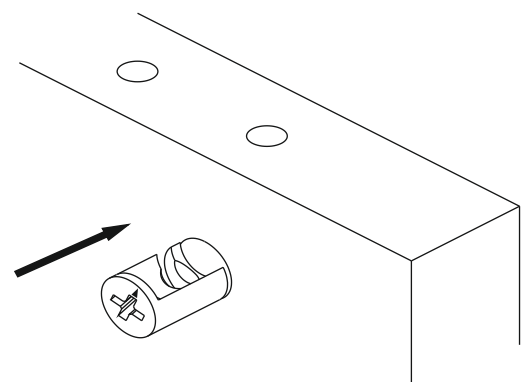

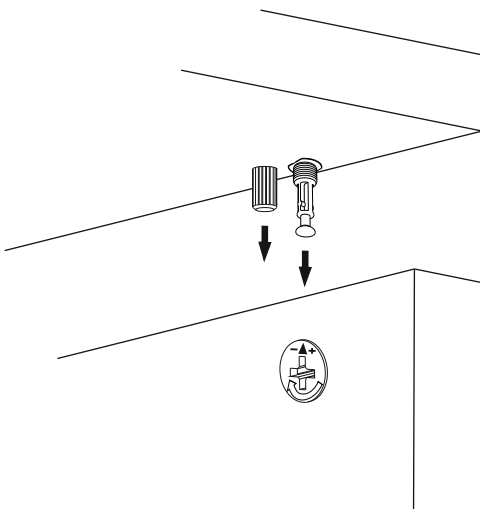

*After attaching two pieces please turn the A02 (minifix head) clockwise direction with the help of a screwdriver.

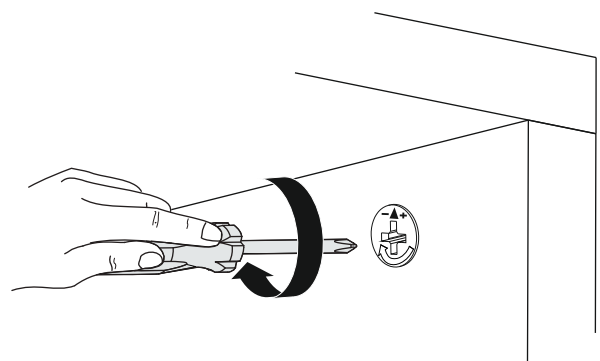

*Please do not over screw the minifix head since it may be broken if too much power is imposed. Just make sure that it is screwed to the direction “+” do not go any further.

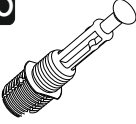
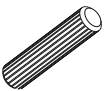

Part1	1x
Part2	2x
Part3	1x
Part4	1x
Part5	2x
Part6	2x
Part7	2x
TOTAL	11x

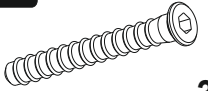
A02 minifix screw  21x	A03 minifix head  21x	A04 dowel $\varnothing 8$  20x	A07 18 mm sticker  24x	A13 50 mm screw  3x
---	--	---	---	--

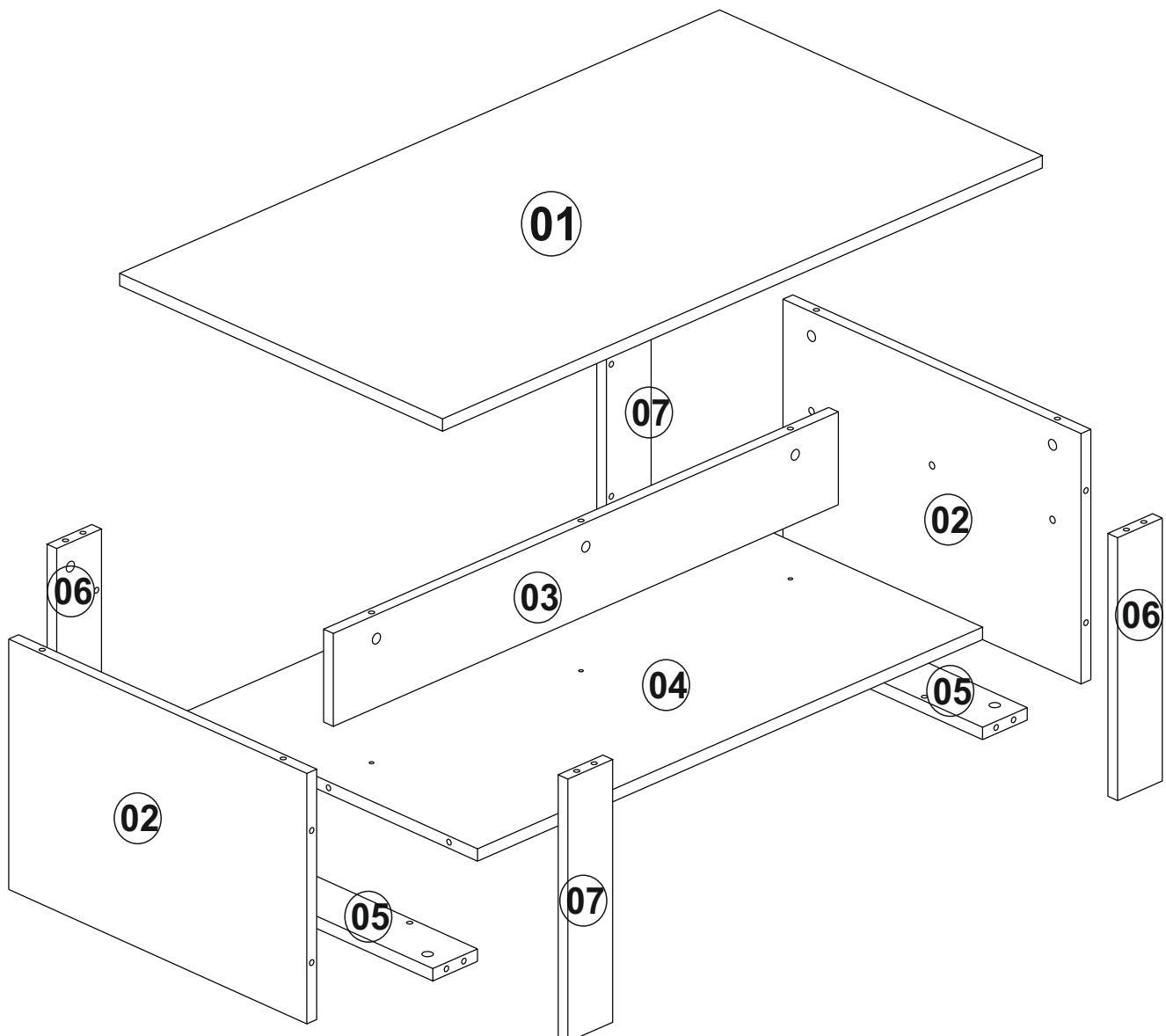

1

step a

*Please insert A03 (minifix screw) into the holes on the piece #2,#6 and #7 as shown below

*Please insert A04 (dowel) into the holes on the piece #5,#6 and #7 as shown below

*Please insert A02 (minifix head) into the holes on the all pieces as shown below

*Make sure that all the arrows on A02 (minifix head) are in correct direction

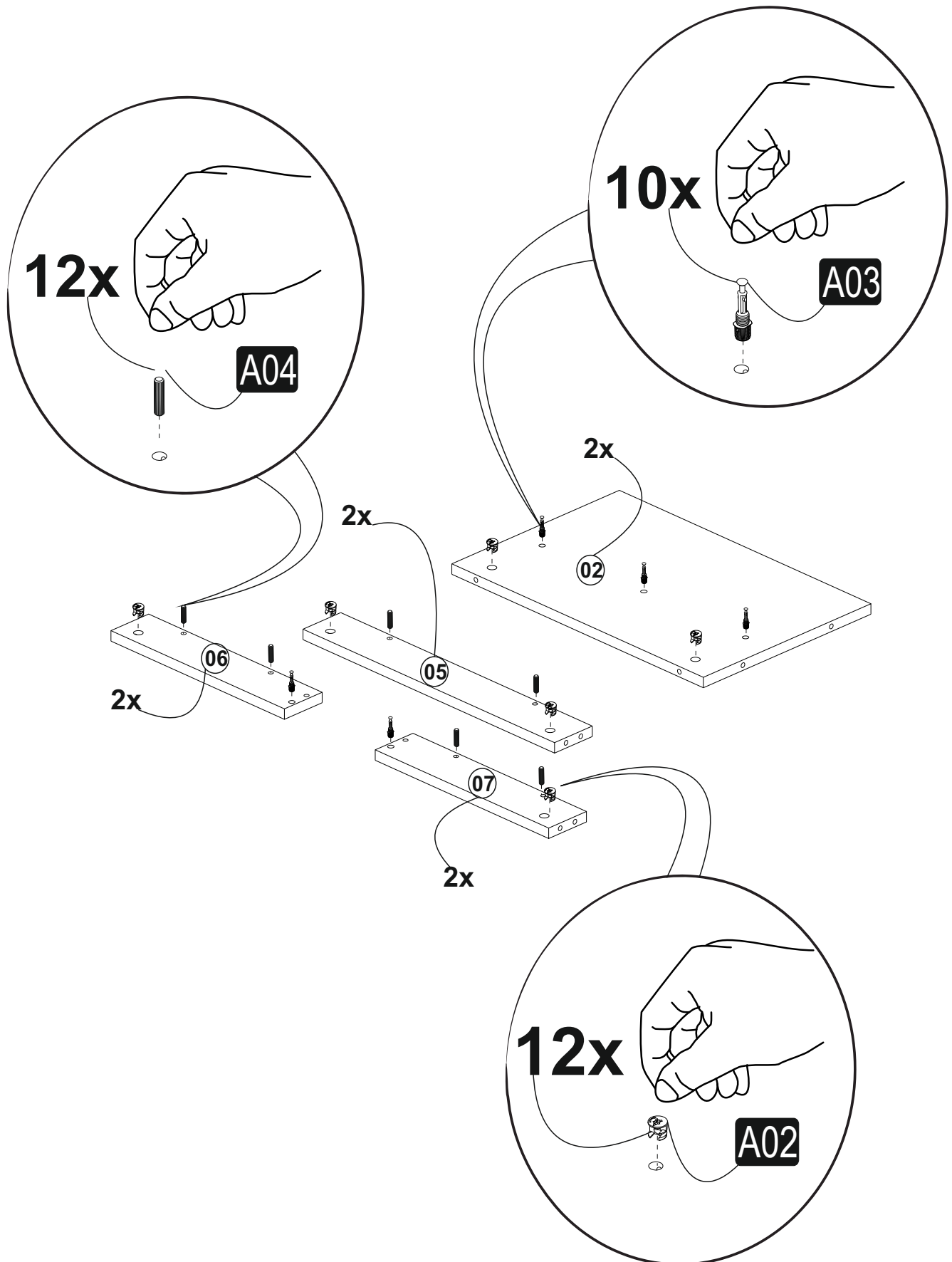

2 step b

- *Please attach the piece #5 to the pieces #2 as shown below
- *Please attach the pieces #6 and #7 to the pieces #2 and #5 as shown below
- *Now screw the A02 (minifix head) clockwise direction with the help of screwdriver

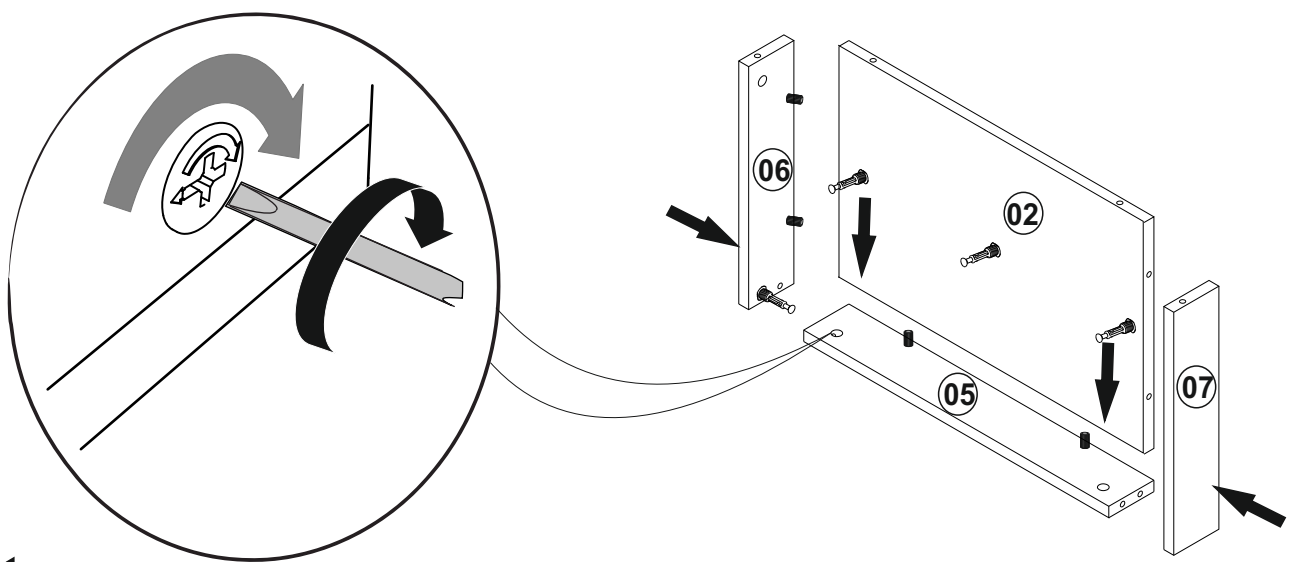

3 step c

- *Please insert A03 (minifix screw) into the holes on the piece #1 as shown below
- *Please insert A04 (dowel) into the holes on the piece #1 as shown below
- *Please insert A02 (minifix head) into the holes on the pieces #3 as shown below
- *Make sure that all the arrows on A02 (minifix head) are in correct direction

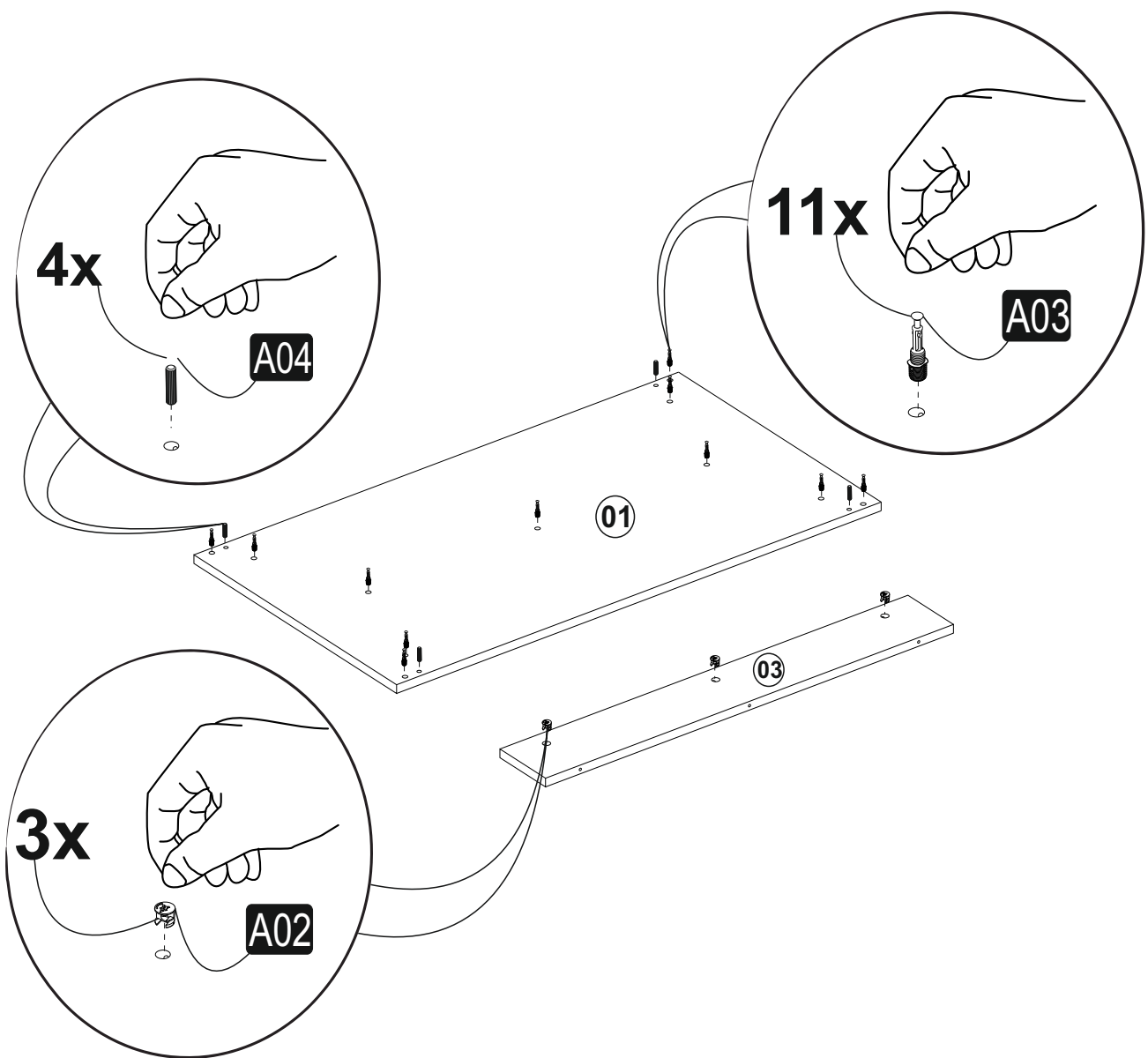

4 step d

- *Please insert A02 (minifix head) into the holes on the pieces #4 as shown below
- *Make sure that all the arrows on A02 (minifix head) are in correct direction

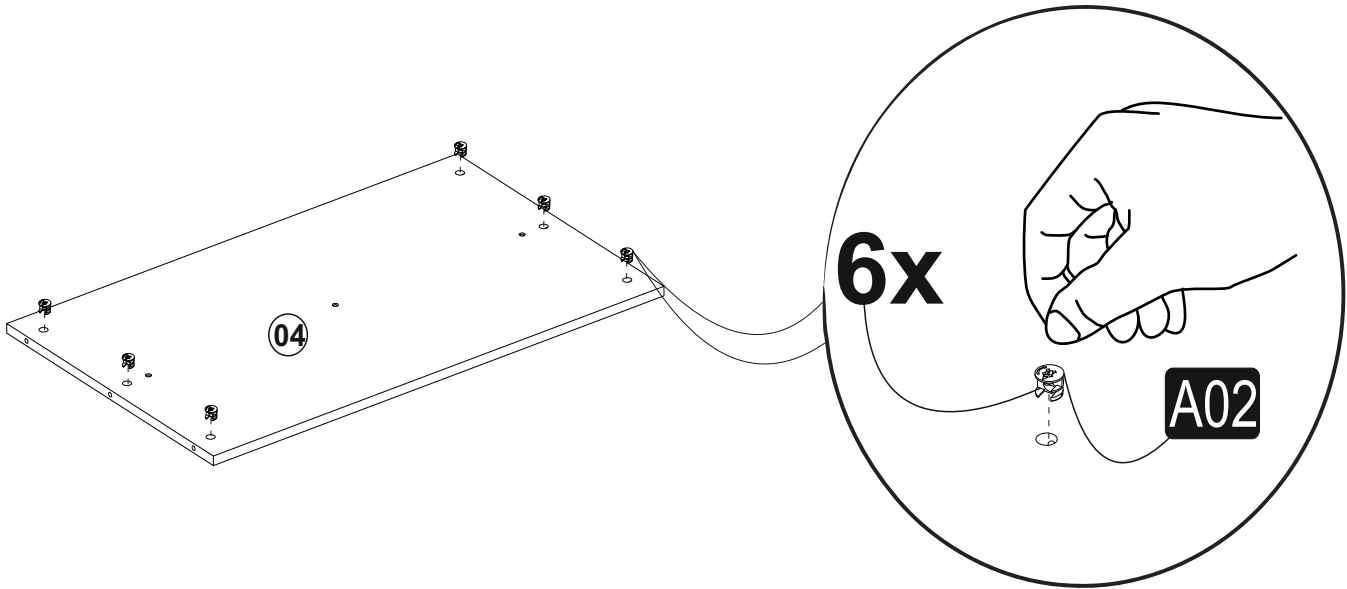

5 step e

- *Please attach **the parts we installed in step b** to the piece #4 as shown below
- *Now screw the A02 (minifix screw) clockwise direction with the help of screwdriver.

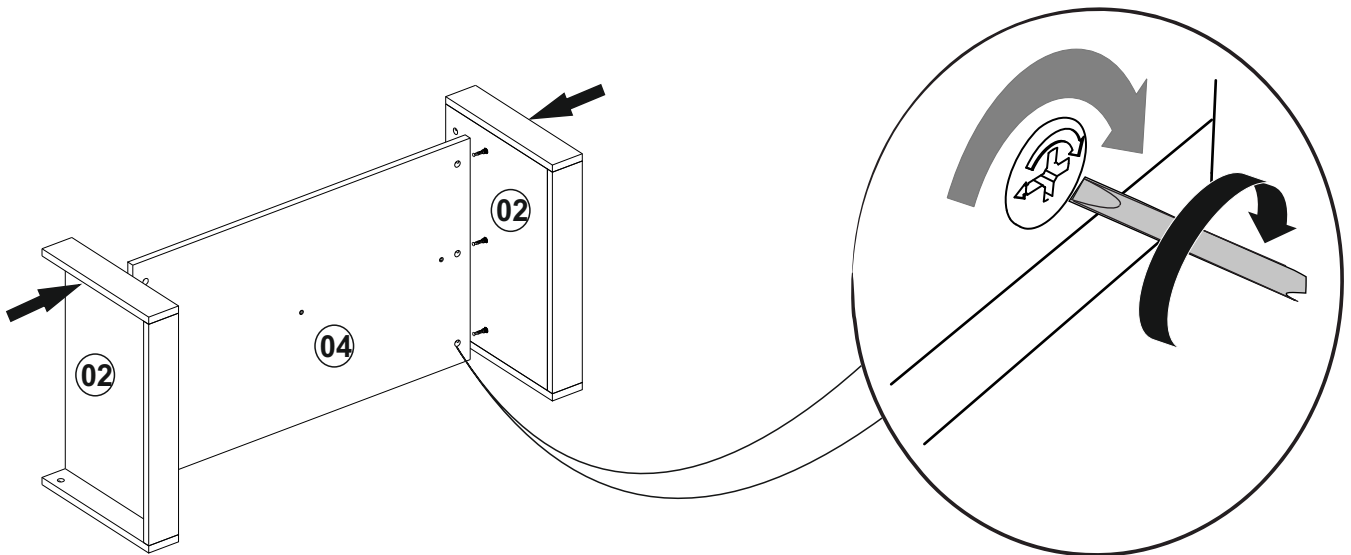

6 step f

*Please attach the #piece #3 onto the piece #4 as shown below

*Now screw the A13 (50 mm screw) clockwise direction with the help of screwdriver.

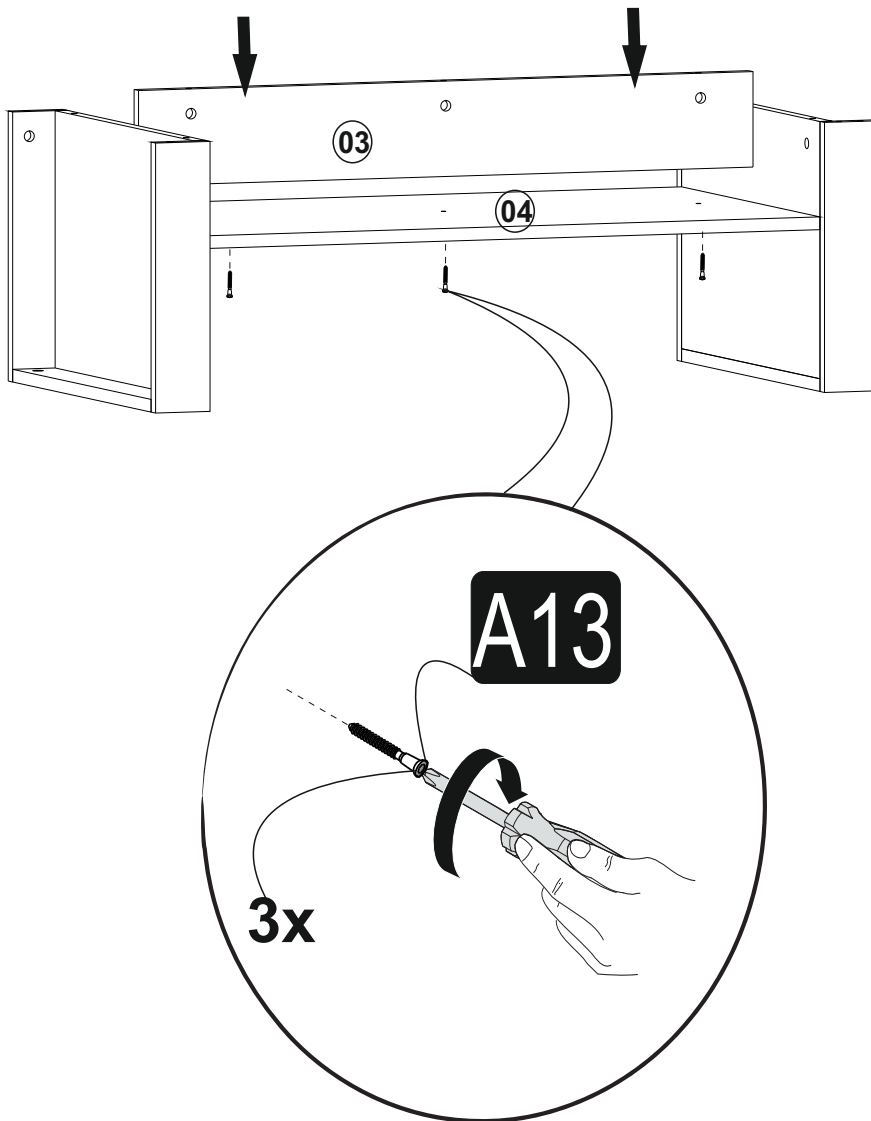

7 step g

*Please attach the piece #1 onto the top of the furniture as shown below

*Now screw the A02 (minifix head) clockwise direction with the help of screwdriver

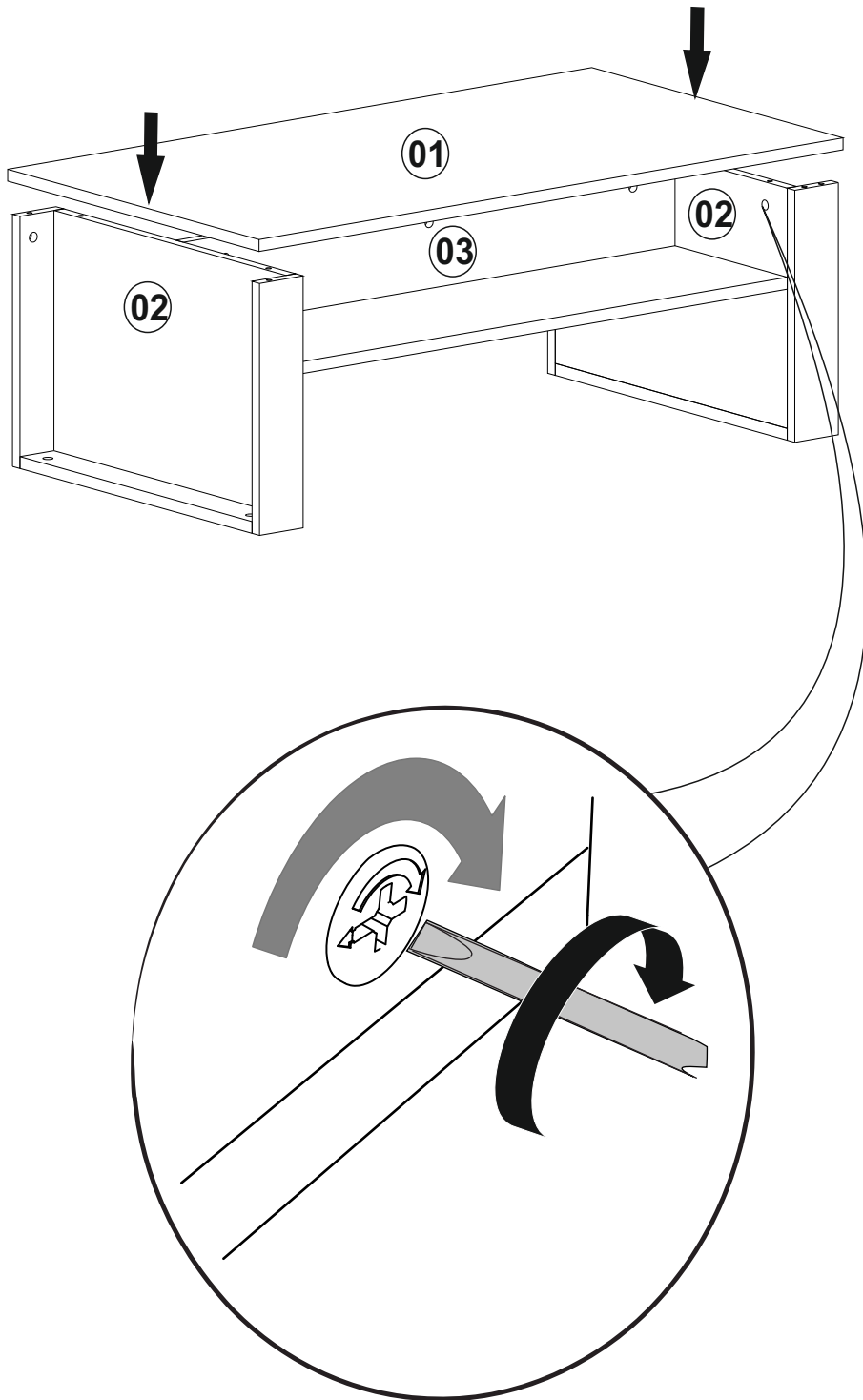

8

step h

*For the best appearance of your furniture please place all A07(18 mm sticker) onto the A13 (50 mm screw) and A02(minifix head).

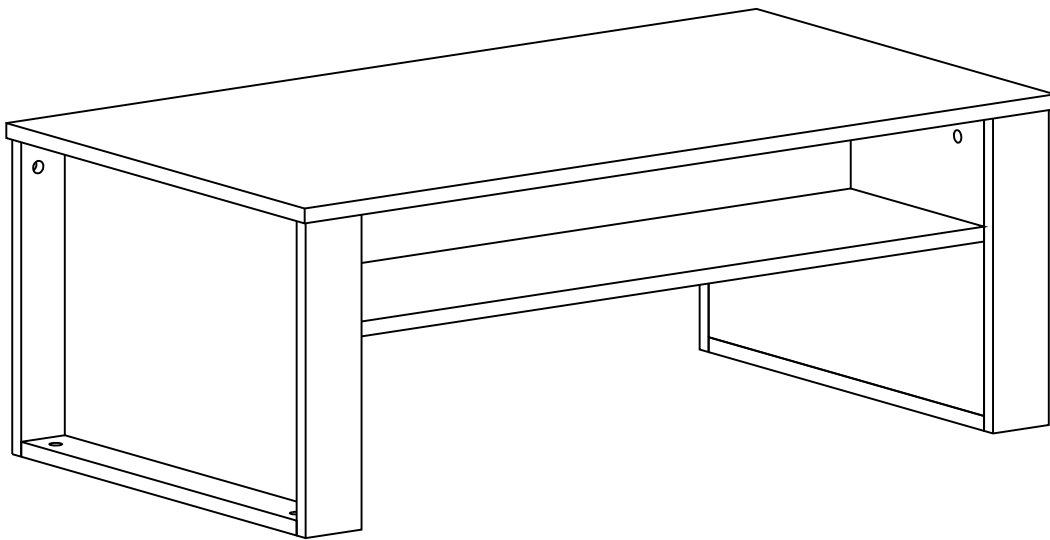
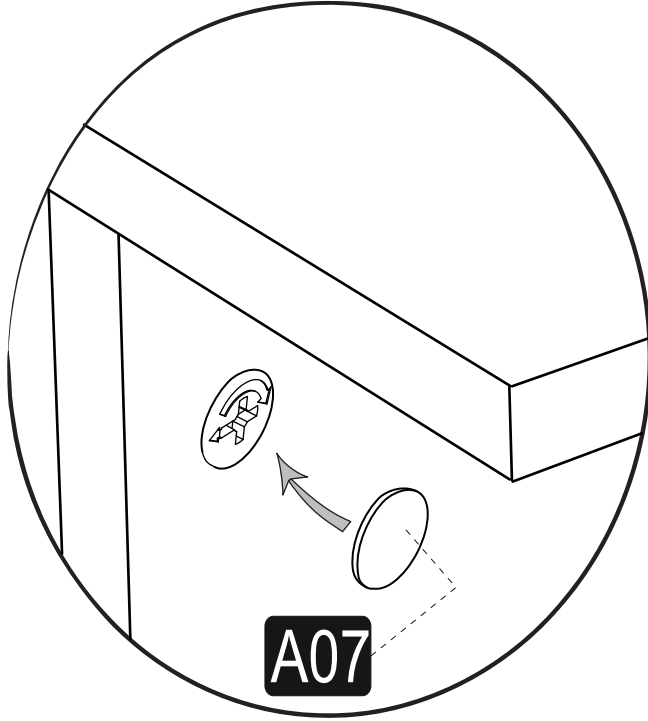

final look

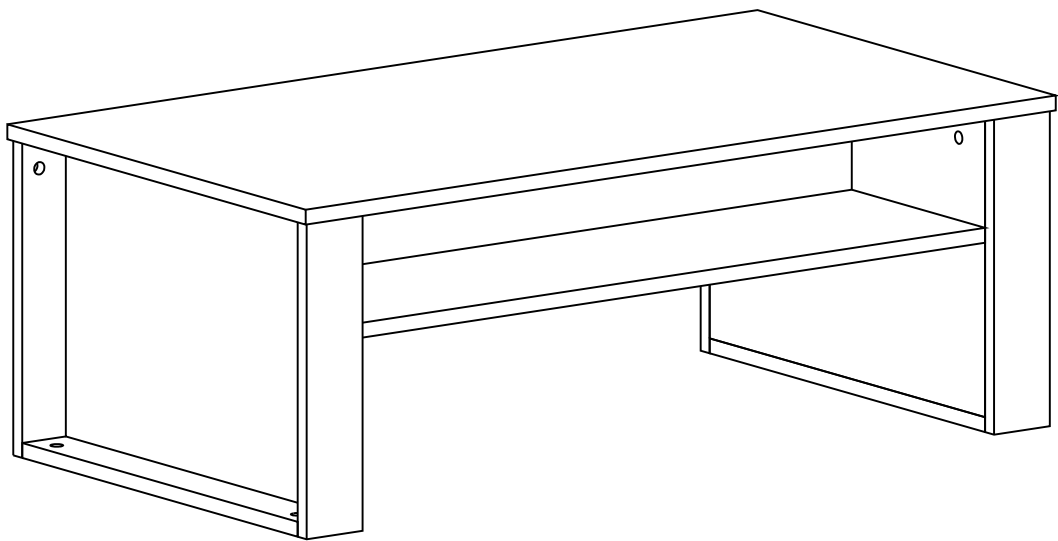

Enjoy your product!