

ASSEMBLY INSTRUCTIONS

FULL BED

Caution: Please read instructions thoroughly before unpacking assembly parts. Sharp exposed staple tips can cause injury, therefore, for your protection, please remove any exposed staples used in packing.

- 1 We recommend that you should assemble this product with the assistance of another person; this will make assembly easier, and will help to eliminate damage to the product or injury to persons during assembly.
- 2 Be sure to check all packing materials carefully for small parts that may have come loose inside the carton during shipment.
- 3 Please do not over-tighten screws or bolts.
- 4 Please put all parts on a non-abrasive floor before assembly, and follow the assembly steps to assemble your newly purchased product correctly and efficiently.

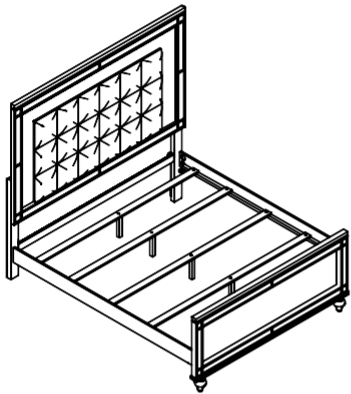

Hardware List For Headboard (F 1741-10-1)				Hardware List For Footboard (F 1741-11-1)			
1		JCBC Bolt (Ø5/16" x 60mm)	6 Pcs	8		FULL THREAD BOLT (Ø5/16"x90)	8 Pcs
2		Spring washer (Ø5/16"x13x1.2)	6 Pcs	9		Corved Washer (Ø5/16")	8 Pcs
3		Flat washer (Ø5/16"x19x2)	6 Pcs	10		NUT washer (Ø5/16")	8 Pcs
4		JCBC Bolt (Ø1/4" x 38mm)	2 Pcs	11		Wrench key' 1/2"x90mm	1 Pc
5		Spring washer (Ø1/4"x13x1.2)	2 Pcs	Hardware Bag For Footboard (F 1741-12-1)			
6		Flat washer (Ø1/4"x19x2)	2 Pcs				
7		Allen Key L57 x4 mm	1 Pc	12		Wood Screw Ø4x25	8 Pcs
Tools Required: Please use a screwdriver for the screwdriver is not included.							

PARTS LIST - LISTA DE PARTES

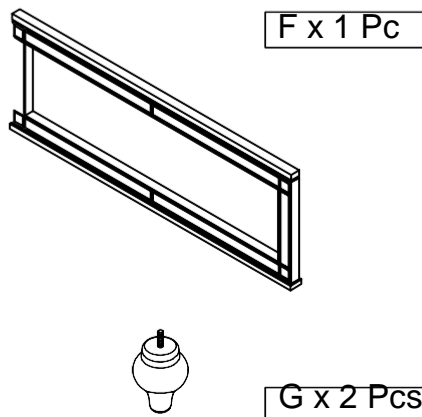
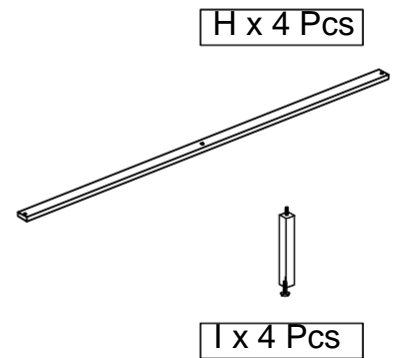
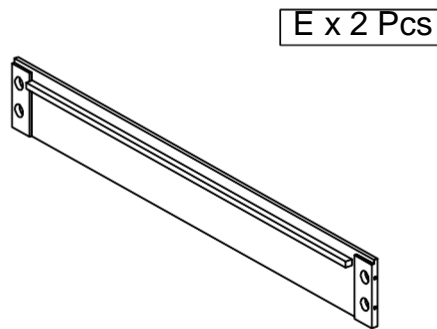
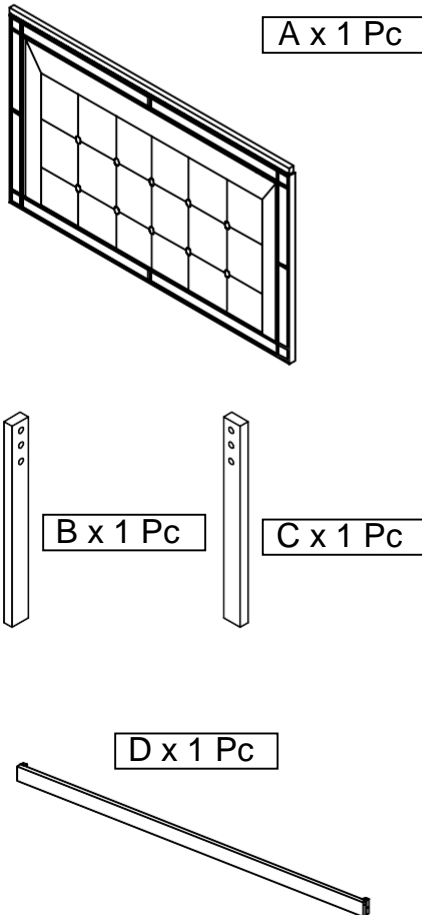

ASSEMBLY INSTRUCTIONS

FULL BED

STEP 1

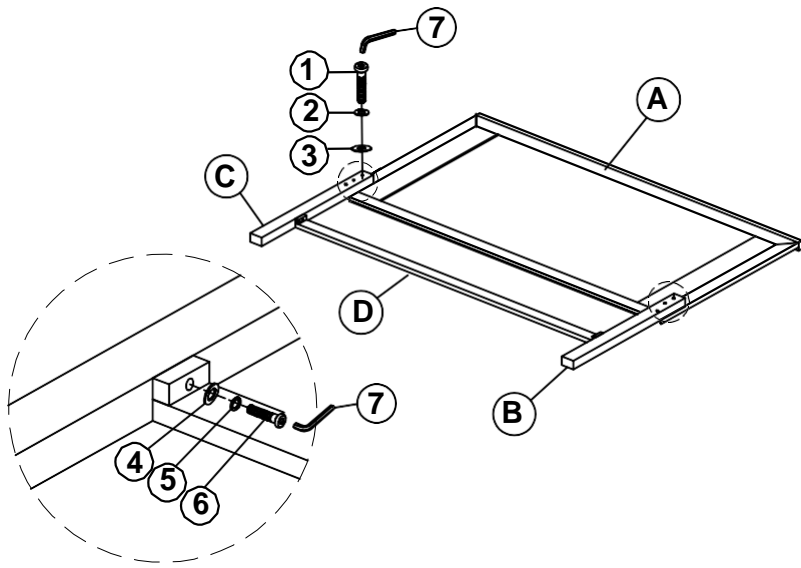

STEP 2

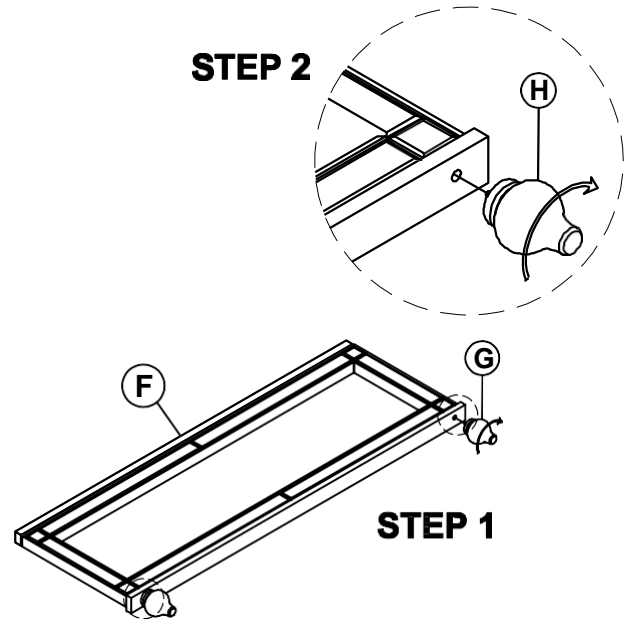

STEP 3

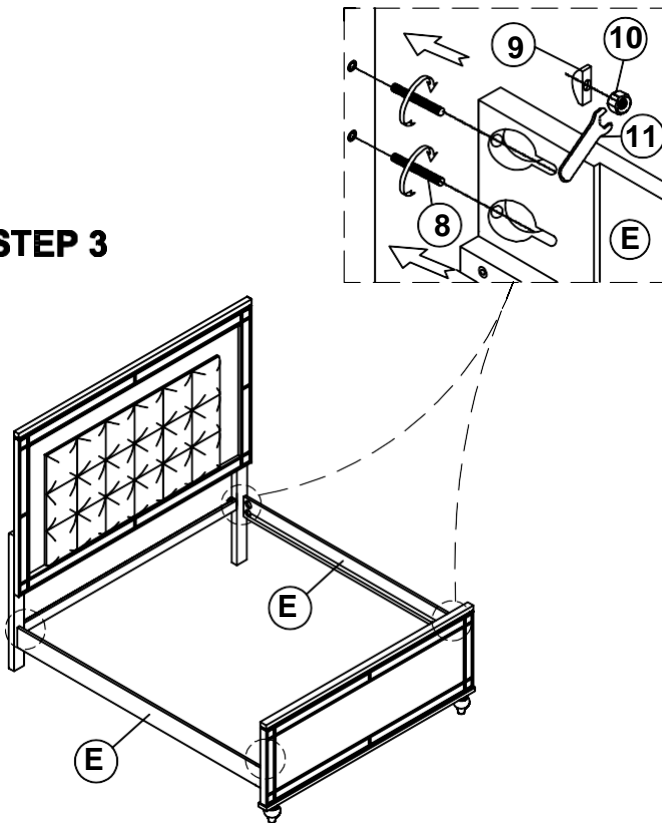

STEP 4

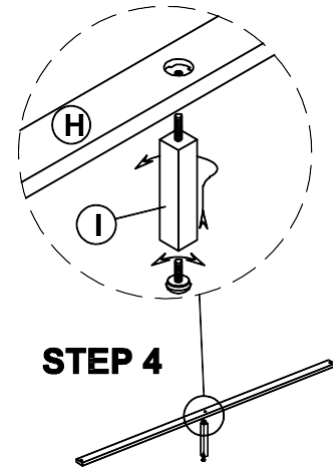

STEP 5

