

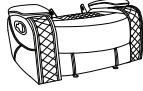



**ASSEMBLY INSTRUCTIONS**  
**ORION II COLLECTION**  
**ITEM#: U1769V-13**  
**DESCRIPTION : ORION II GLIDER RECLINER**

Thank you for purchasing this quality product. Be sure to check all packing materials carefully for small parts, which may have come loose during shipment. Identify and count all items and compare with the parts list shown below. It is recommended to have two people during assembling and to remove the back and base of the furniture out from the box. **Please follow the drawings below to assemble the item**

PARTS LIST			
NO.	DESCRIPTION	SKETCH	QTY
A	Seat		1PC
B	Backrest		1PC
C	Left Side Facing (LSF) Wing		1PC
D	Right Side Facing (RSF) Wing		1PC

All images shown are for illustration purpose only.  
 Actual product may vary due to product enhancement.

# ASSEMBLY INSTRUCTIONS

## ORION II COLLECTION

**ITEM#:** U1769V-13

**DESCRIPTION :** ORION II GLIDER RECLINER

**Step 1:**  
Check the bottom of the Seat (A) to cut and remove any fastener that is holding the mechanism in place during transportation.

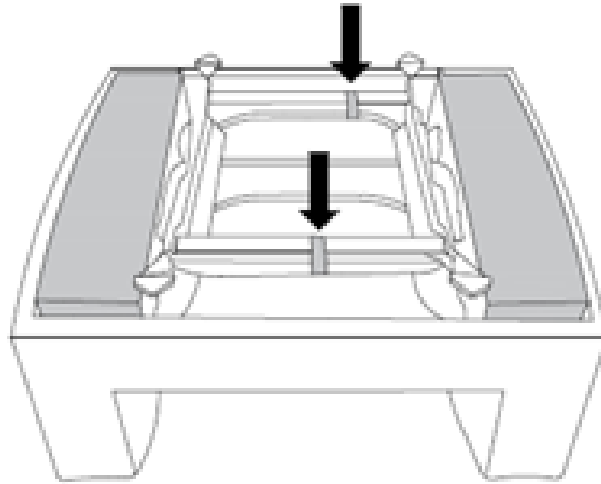

**Step 2:**  
Insert the backrest (B) to the seat (A) and make sure the backrest is secured in position.

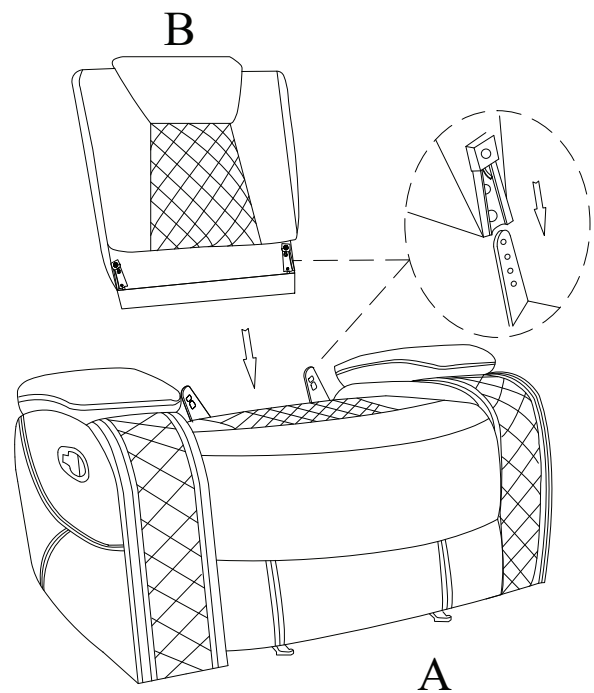

All images shown are for illustration purpose only.  
Actual product may vary due to product enhancement.

**Step 3 :**

Attach the LSF and RSF Wings (C & D) to the backrest (B).

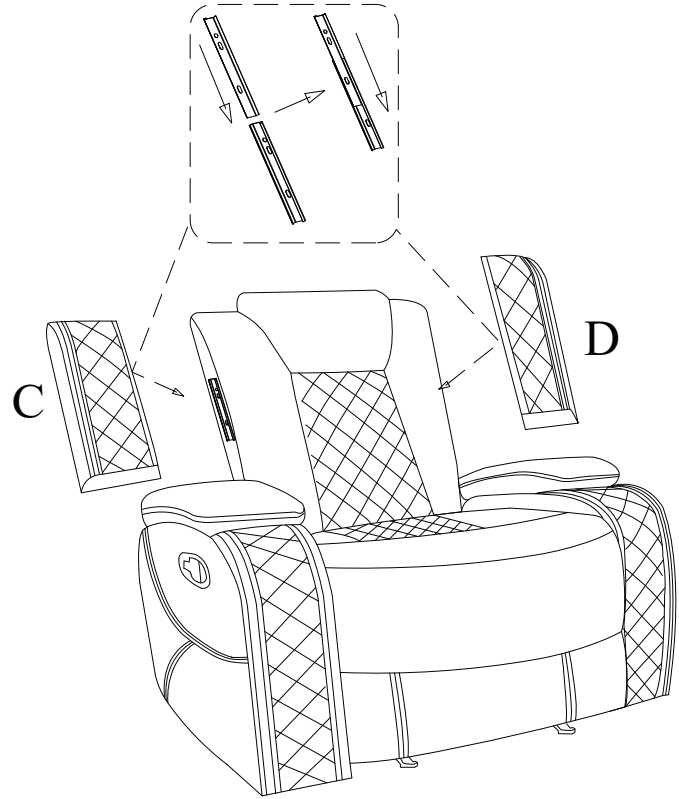

**Step 4:**

Open the footrest by pulling the handle.

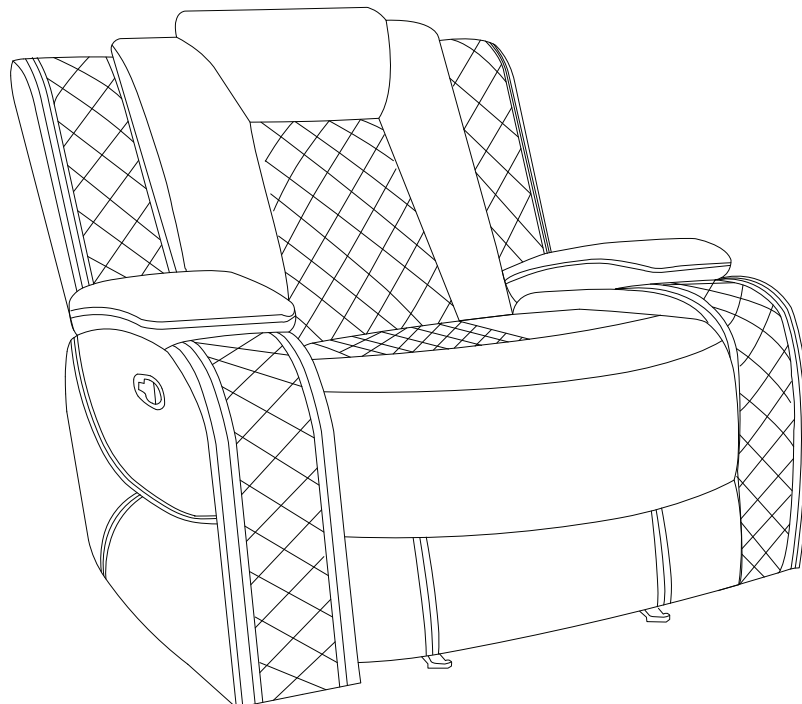

All images shown are for illustration purpose only.  
Actual product may vary due to product enhancement.







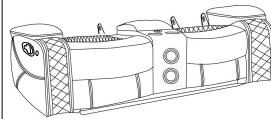

# ASSEMBLY INSTRUCTIONS

## ORION II COLLECTION

ITEM#: U1769V-25

DESCRIPTION : ORION II CONSOLE LOVESEAT  
W/ DUAL RECLINERS

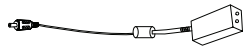
Thank you for purchasing this quality product. Be sure to check all packing materials carefully for small parts, which may have come loose during shipment. Identify and count all items and compare with the parts list shown below. It is recommended to have two people during assembling and to remove the back and base of the furniture out from the box. **Please follow the drawings below to assemble the item**

PARTS LIST			
NO.	DESCRIPTION	SKETCH	QTY
A	Seat		1PC
B	Left Side Facing (LSF) Backrest		1PC
C	Console backrest		1PC
D	Right Side Facing (RSF) Backrest		1PC
E	Left Side Facing (LSF) Wing		1PC
F	Right Side Facing (RSF) Wing		1PC
G	Power Cable 12V		1PC
H	Transformer		1PC
I	Power Connector		1PC

All images shown are for illustration purpose only.  
Actual product may vary due to product enhancement.

# ASSEMBLY INSTRUCTIONS

## ORION II COLLECTION

ITEM#: U1769V-25

DESCRIPTION : ORION II CONSOLE LOVESEAT W/ DUAL RECLINERS

Step 1:  
Take out the console backrest stored under the RSF arm. Unscrew the knob screws from the console backrest (C).

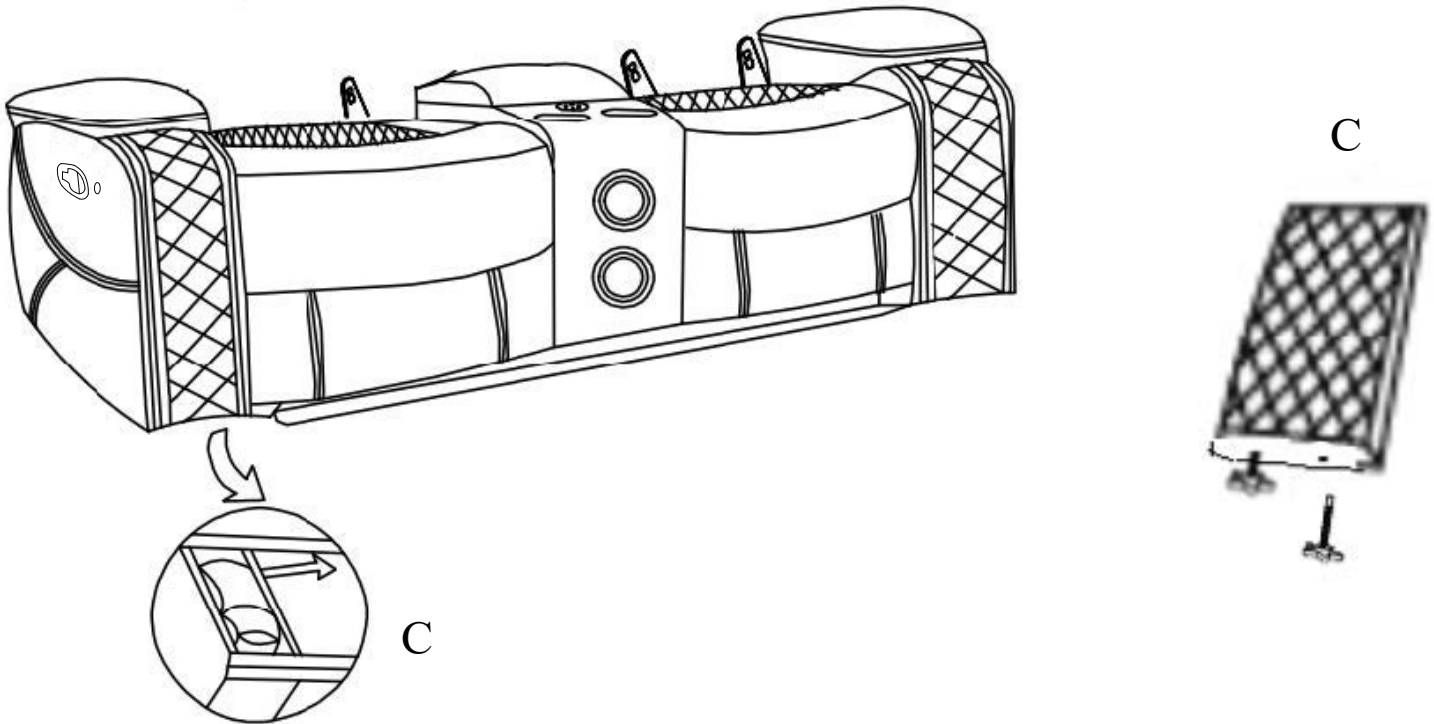

Step 2:  
Open the zipper at the center back of the seat(A).

Back view

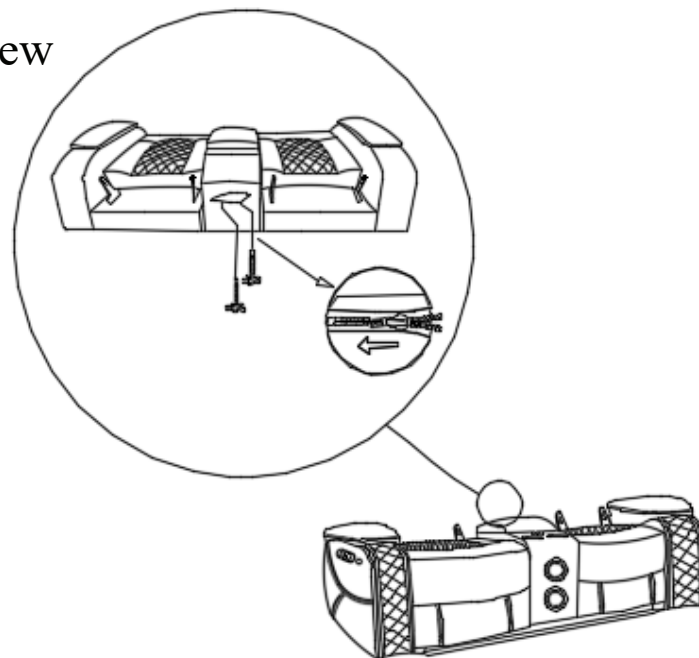

All images shown are for illustration purpose only.  
Actual product may vary due to product enhancement.

# ASSEMBLY INSTRUCTIONS

## ORION II COLLECTION

ITEM#: U1769V-25

DESCRIPTION : ORION II CONSOLE LOVESEAT W/ DUAL RECLINERS

Step 3:  
Place the console Backrest (C) in the correct position and then attach to the seat (A) by turning the knob screws from inside the zipper counterclockwise.

Back view

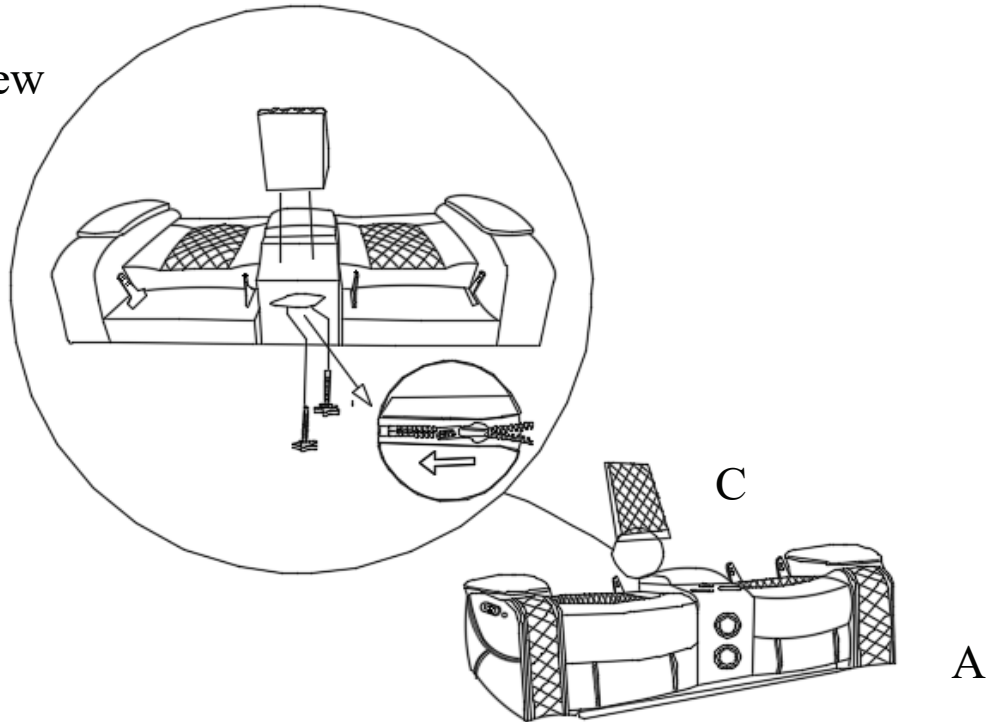

Step 4:  
Insert the LSF backrest (B) and the RSF backrest (D) to the seat (A). Make sure the backrests are secured in position.

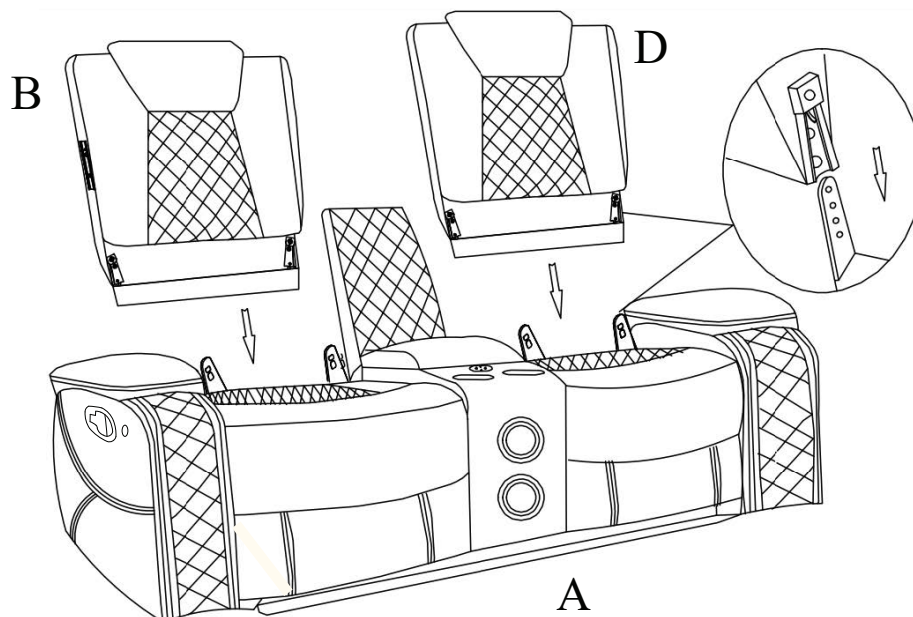

All images shown are for illustration purpose only.  
Actual product may vary due to product enhancement.

# ASSEMBLY INSTRUCTIONS

## ORION II COLLECTION

ITEM#: U1769V-25

DESCRIPTION : ORION II CONSOLE LOVESEAT  
W/ DUAL RECLINERS

### Step 5:

Insert the LSF wing(E) to the LSF backrest(B) and insert the RSF wing(F) to the RSF backrest(D). Make sure the wings are secured in position.

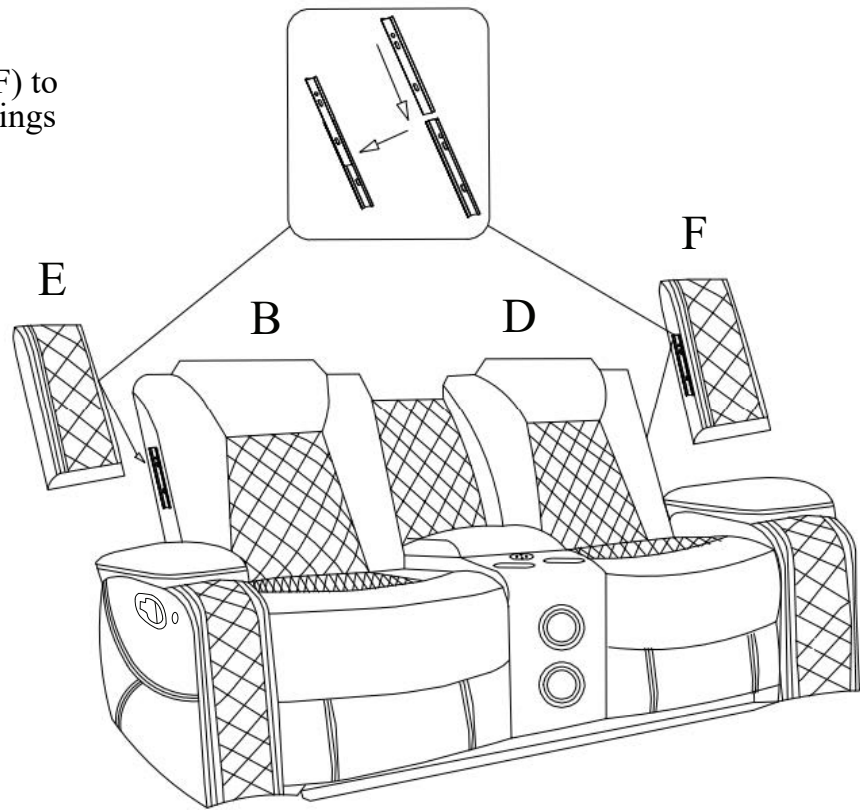

### Step 6:

Locate the electric cable which is fasted to the metal frame at the back center of the seat (A). Connect the Transformer (H) to the electric cable on Seat (A) then connect the Power Connect (I) to the Transformer (H).

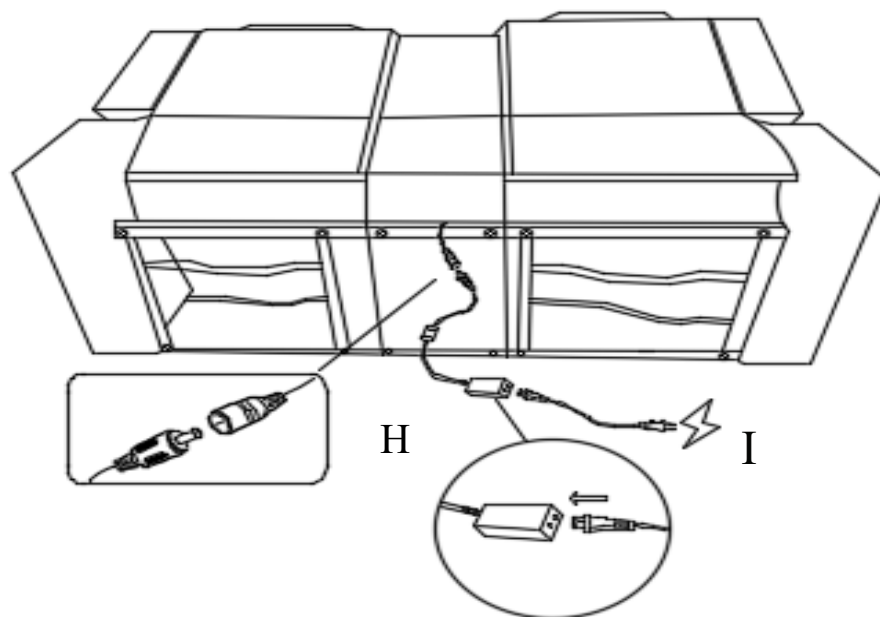

All images shown are for illustration purpose only.  
Actual product may vary due to product enhancement.

# ASSEMBLY INSTRUCTIONS

## ORION II COLLECTION

ITEM#: U1769V-25

DESCRIPTION : ORION II CONSOLE LOVESEAT  
W/ DUAL RECLINERS

### Step 7:

Locate power cable fastened to the metal frame near the back on the side of the seat (A).  
Connect the Power Cable 12 V (G) to the power cable on seat (A).

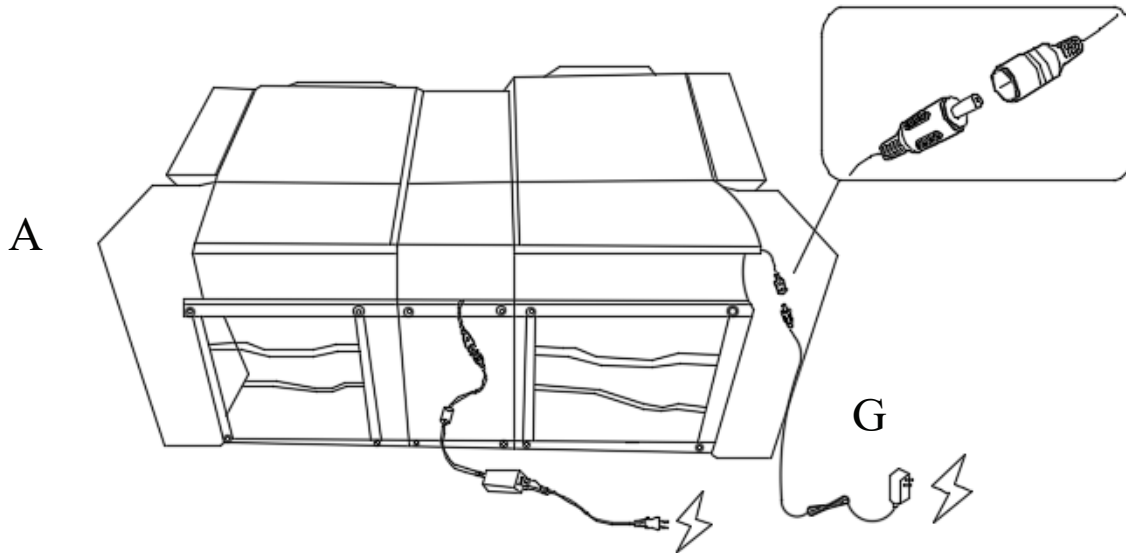

### Step 8:



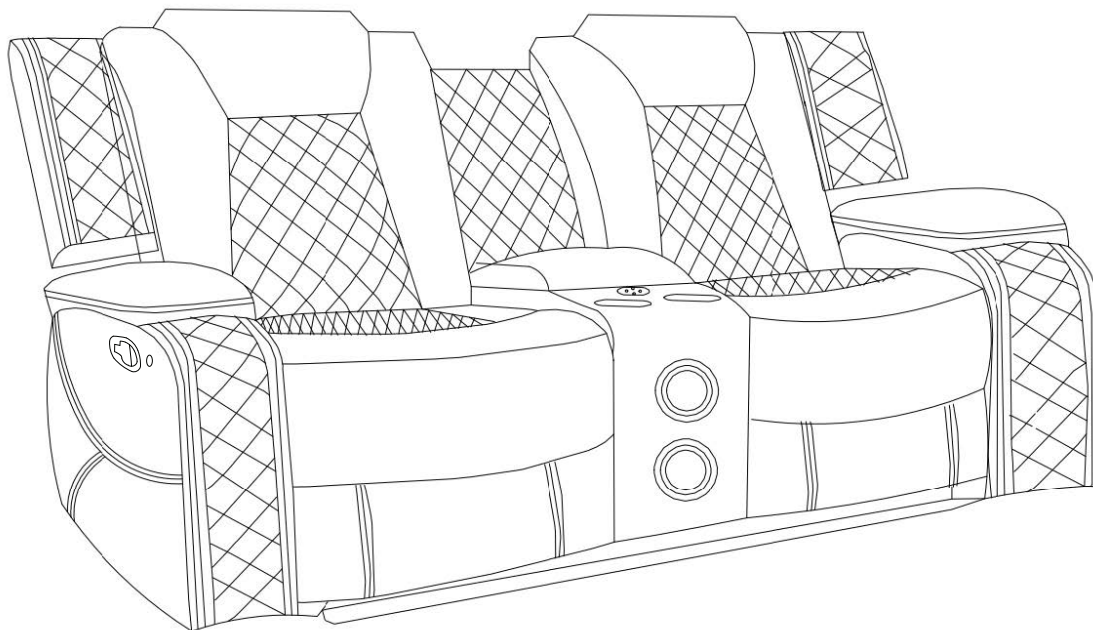





Open the footrest by pulling the handle.

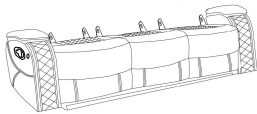

All images shown are for illustration purpose only.  
Actual product may vary due to product enhancement.

**ASSEMBLY INSTRUCTIONS**  
**ORION II COLLECTION**  
**ITEM#: U1769V-30**  
**DESCRIPTION : ORION II SOFA W/DUAL RECLINER**

Thank you for purchasing this quality product. Be sure to check all packing materials carefully for small parts, which may have come loose during shipment. Identify and count all items and compare with the parts list shown below. It is recommended to have two people during assembling and to remove the back and base of the furniture out from the box. **Please follow the drawings below to assemble the item**

PARTS LIST			
NO.	DESCRIPTION	SKETCH	QTY
A	Seat		1PC
B	Left Side Facing (LSF) Backrest		1PC
C	Mid backrest		1PC
D	Right Side Facing (RSF) Backrest		1PC
E	Left Side Facing (LSF) Wing		1PC
F	Right Side Facing (RSF) Wing		1PC
G	Power Cable 12V		1PC
H	Small Round End Power Cable 9V		1PC

All images shown are for illustration purpose only.  
 Actual product may vary due to product enhancement.

# ASSEMBLY INSTRUCTIONS

## ORION II COLLECTION

ITEM#: U1769V-30

DESCRIPTION : ORION II SOFA W/DUAL RECLINER

Step 1:  
Insert the backrest (B/C/D) to the seat (A) and  
make sure the backrests are secured in position.

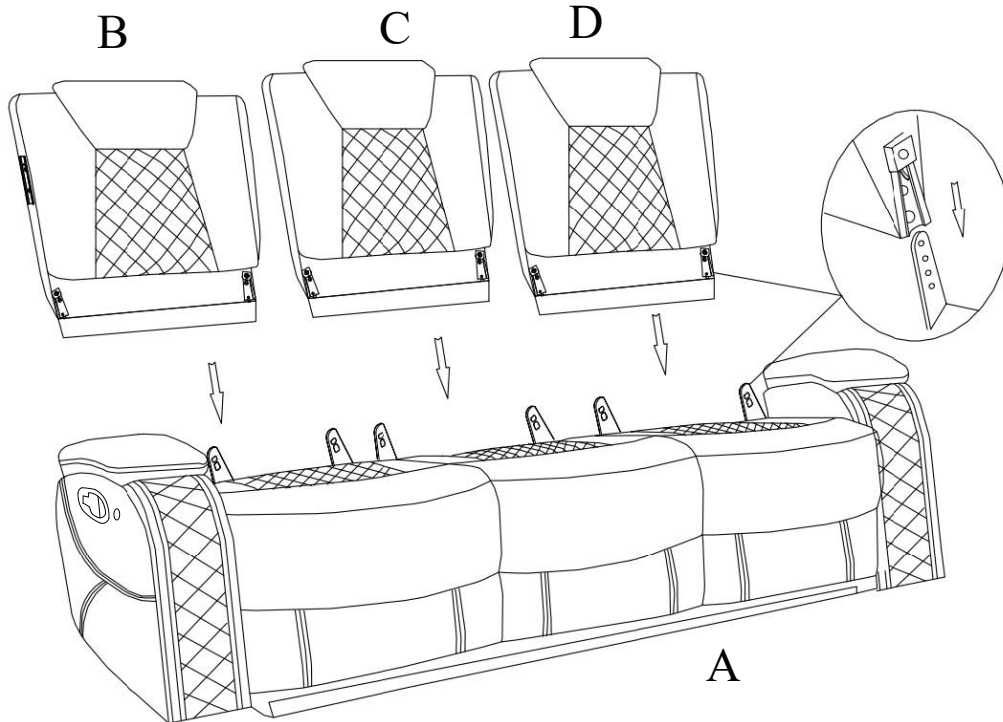

Step 2:  
Insert the LSF wing(E) to the LSF  
backrest(B) and insert the RSF  
wing(F) to the RSF backrest(D).  
Make sure the wings are secured  
in position.

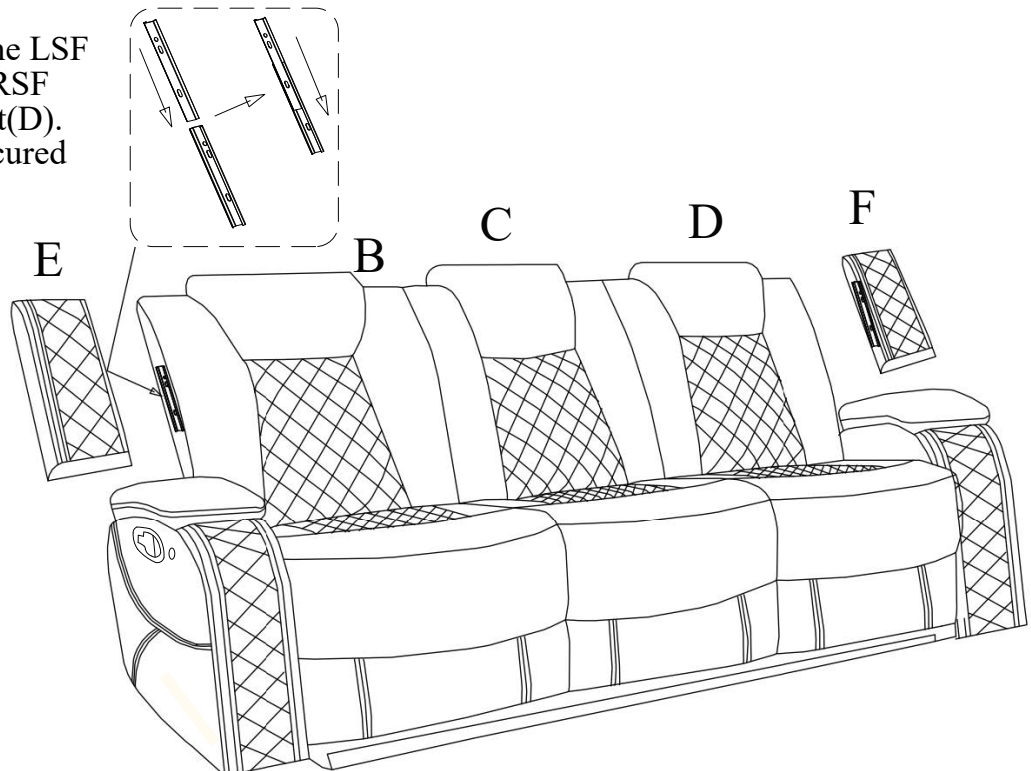

All images shown are for illustration purpose only.  
Actual product may vary due to product enhancement.

# ASSEMBLY INSTRUCTIONS

## ORION II COLLECTION

ITEM#: U1769V-30

DESCRIPTION : ORION II SOFA W/DUAL RECLINER

**Step 3:**  
Locate the two round electric cables which is fasted to the metal frame near the back center of the seat (A). Connect the larger round electric motor cables then connect Small Round End Power Cable 9V (H) to the other electric cable with the smaller round end on seat (A).

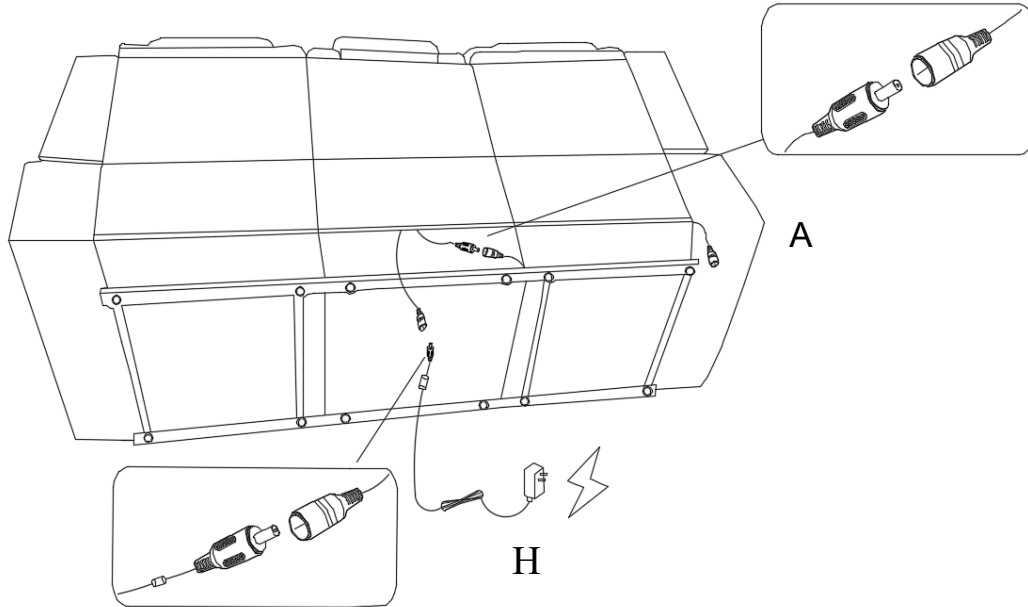

**Step 4:**  
Locate power cable fasted to the metal frame near the back on the side of the seat (A). Connect the Power Cable 12 V (G) to the power cable on seat (A).

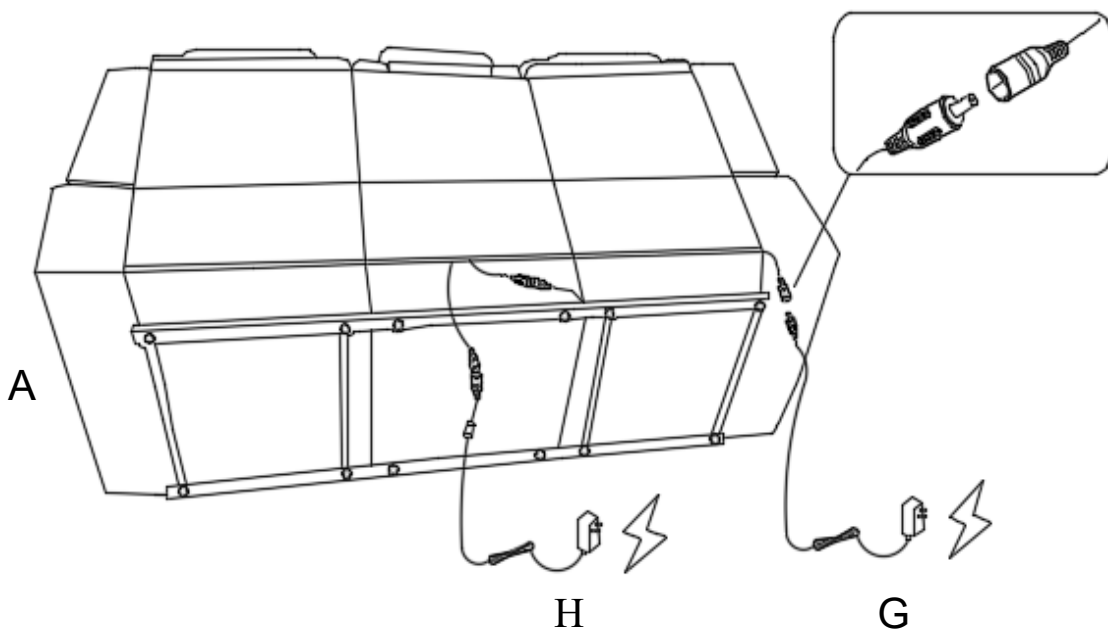

All images shown are for illustration purpose only.  
Actual product may vary due to product enhancement.

# ASSEMBLY INSTRUCTIONS

## ORION II COLLECTION

ITEM#: U1769V-30

DESCRIPTION : ORION II SOFA W/DUAL RECLINER

**Step 5:**

Open the footrest by pulling the handle.

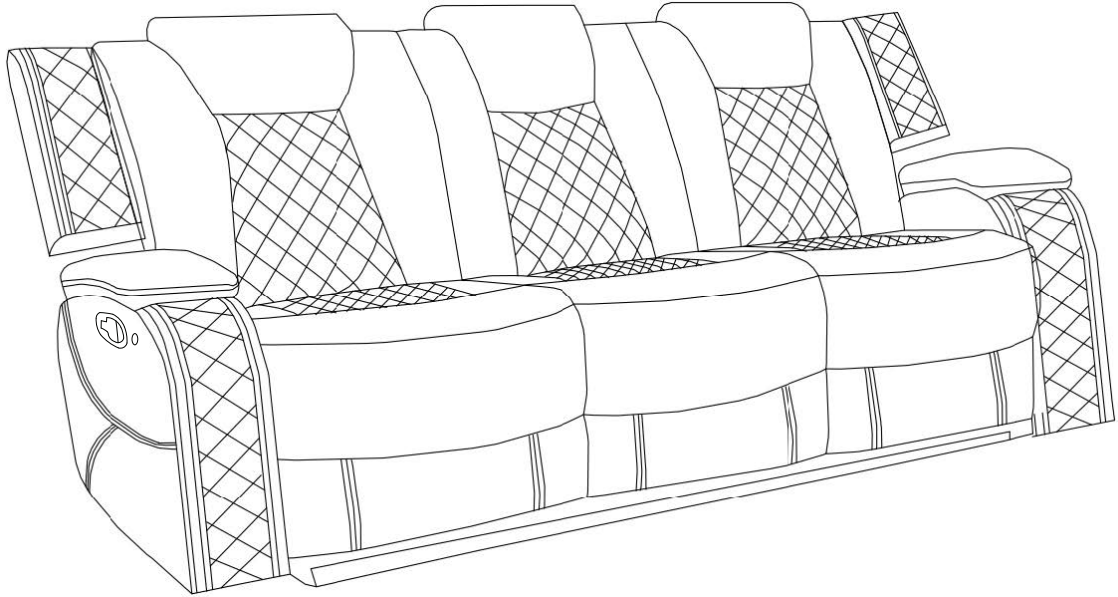

All images shown are for illustration purpose only.  
Actual product may vary due to product enhancement.