

INSTALLATION MANUAL

GUIDE D'INSTALLATION

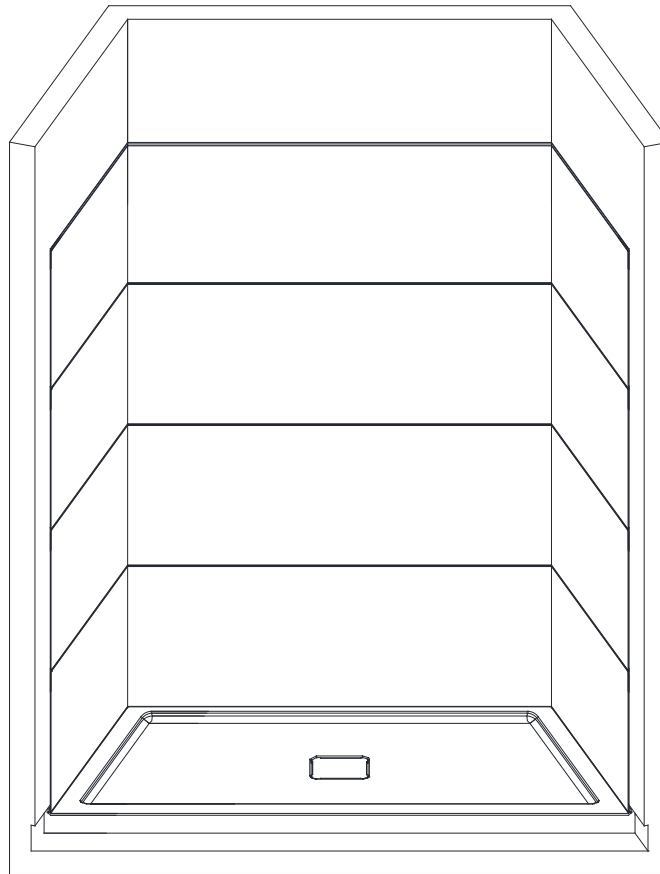

PBF306060	PBF366072
PBF326060	PBF306096
PBF366060	PBF326096
PBF306072	PBF366096
PBF326072	

SPECIFICATION. / SPÉCIFICATION.

Model Modèle	Dimensions*		
	L	W	H
PBF306060/PBF326060/PBF366060/ PBF306072/PBF326072/PBF366072/ PBF306096/PBF326096/PBF366096	30"/32"/36" [762/813/914mm]	60" [1524mm]	60"/72"/96" [1524/1829/2438mm]

* Tolérance sur les dimensions: $\pm 1/4"$ [.6 cm]
Tolerance on dimensions: $\pm 1/4"$ [.6 cm]

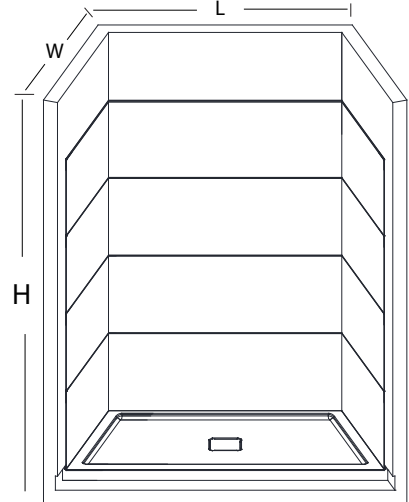

TOOLS AND MATERIALS REQUIRED. / OUTILS ET MATÉRIAUX REQUIS.

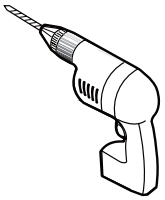

DRILL
PERÇEUSE



DRILL BITS 3/16"
MÈCHE 3/16"

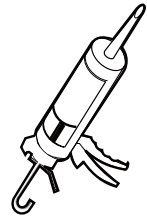

SILICONE
SCÉLLANT



PENCIL
CRAYON

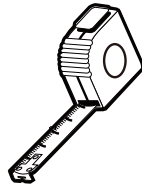

TAPE MEASURE
RUBAN À MESURER

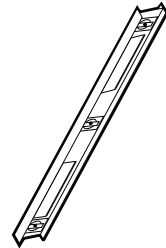

LEVEL
NIVEAU

Elements / Pièces:

A



Front Panels

B



Side Panels

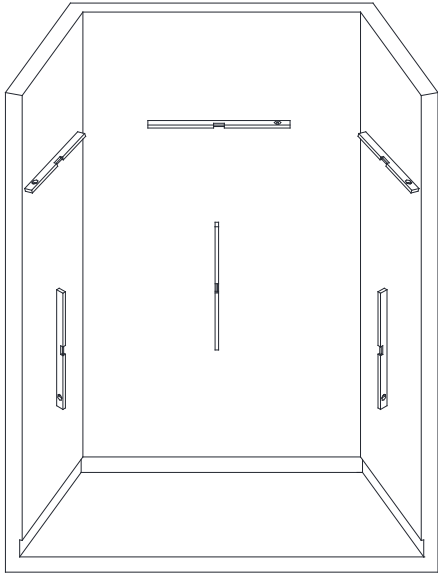

Step 1. Inspect the installation wall to confirm it is level.

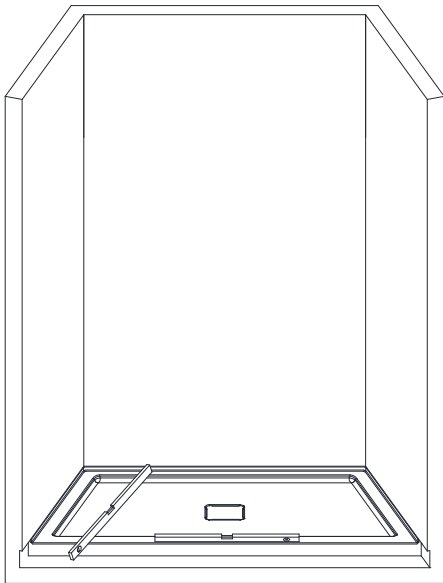

Step 2. Adjust the shower base or bathtub to ensure the surface is level.

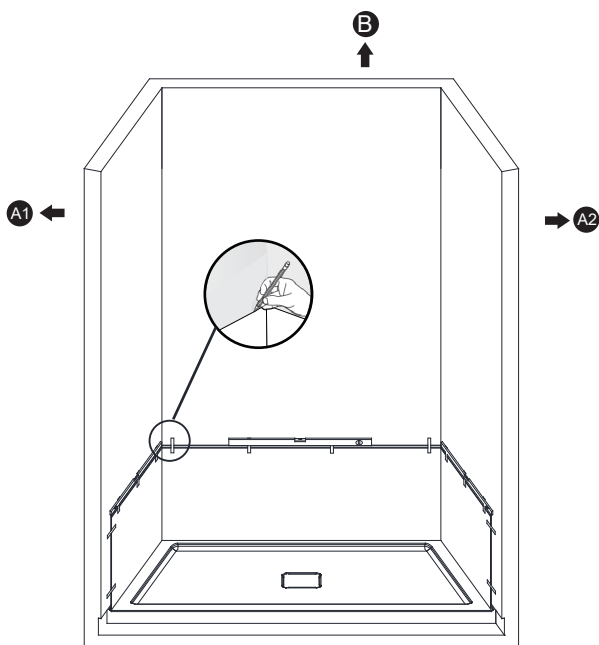

Step 3. Place the first panel into the bathtub or shower base against the wall to verify sizing, Using a level mark a horizontal reference line along the top edge.

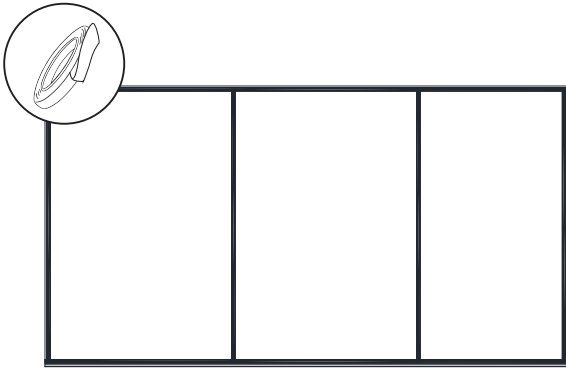

Step 4. Apply 3M double-sided tape to the back panel as illustrated.

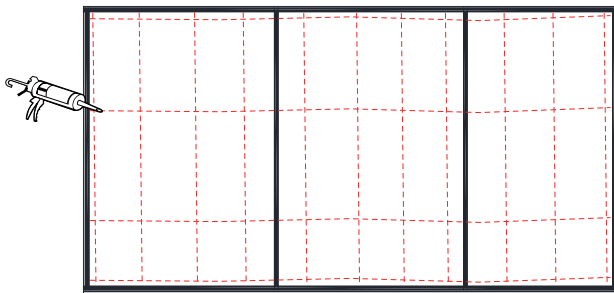

Step 5. Apply adhesive to the back panel surface as shown in the diagram.

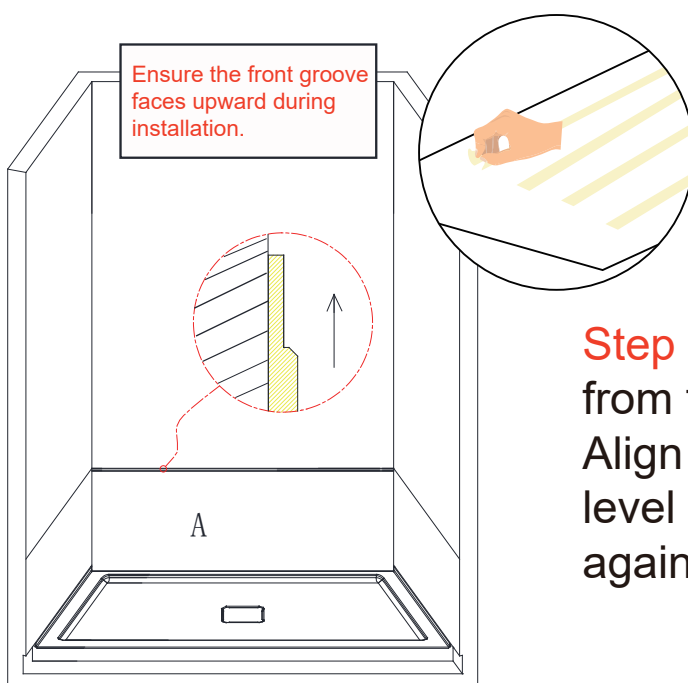

Step 6. Remove the protective film from the 3M tape on Panel A. Align the top edge with the marked level line, press the panel firmly against the wall, and hold to secure.

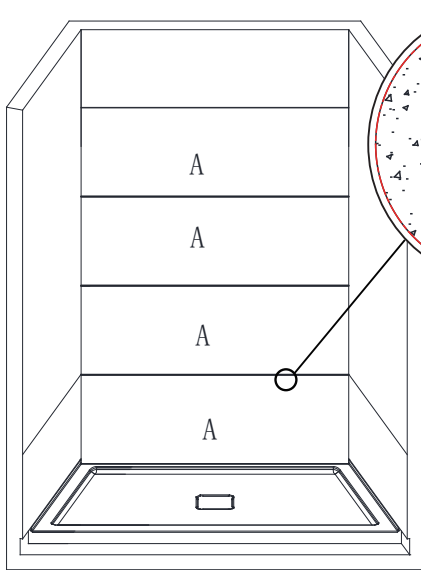

Verify even spacing between panels and ensure flush surface alignment.

Step 7. For additional Panel A sections, repeat the process: remove 3M tape film, apply adhesive, align horizontally, and press firmly into place.

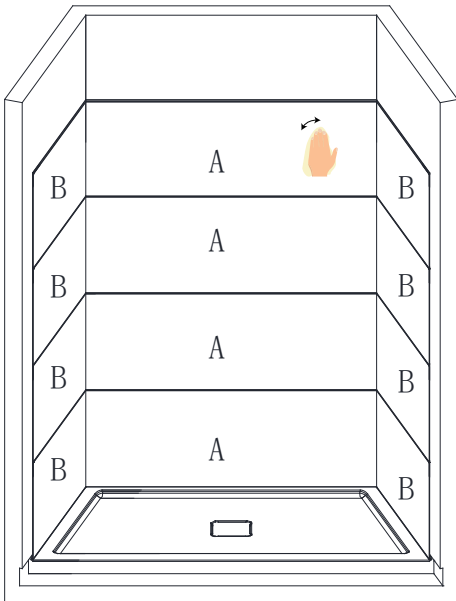

Step 8. Make sure the gaps are flush and the board surface is flat. Repeat the A panel operation process to paste the B panel horizontally upward onto the walls on both sides and press firmly.



24 HOURS

Allow 24 hours for silicone to dry before use

