

Installation & Assembly

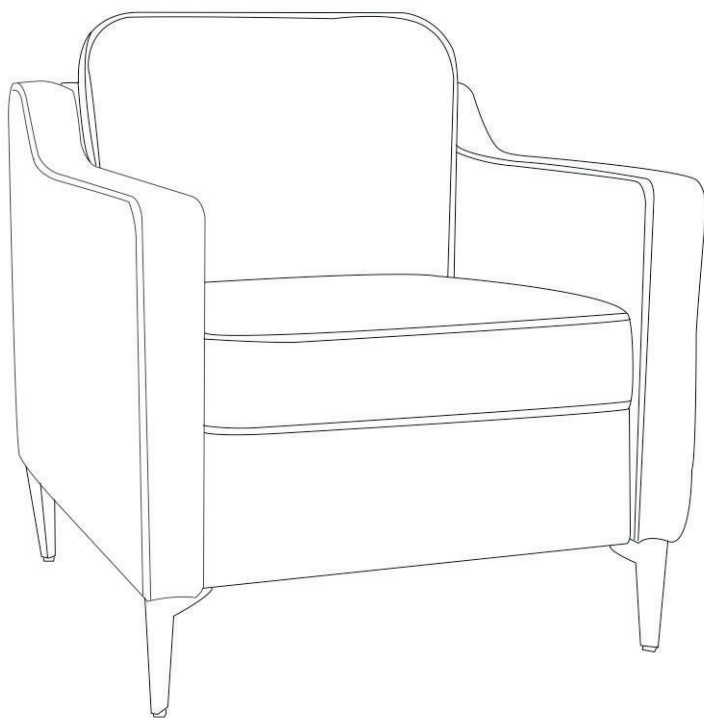

PARTS LIST

Ax2

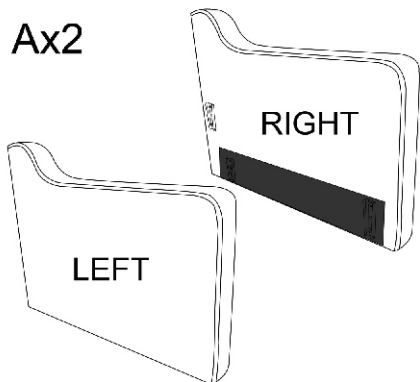

SIDES

Bx1

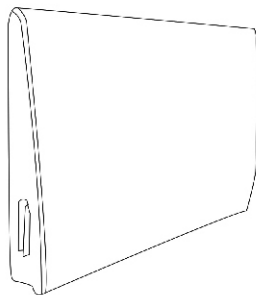

BACK

Cx1

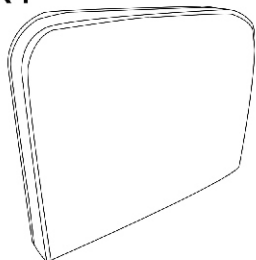

BACK PILLOW

Dx1

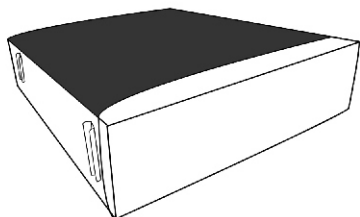

SEAT

Ex1

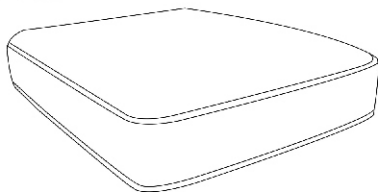

SEAT PILLOW

Fx4

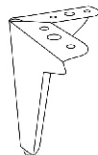

LEGS

HARDWARE&TOOL LIST



Hx8 Bolt (M6x20mm)



Jx8 Washer

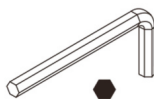

Kx1 Allen key

Be sure to check all packing material fit the packing list. Carefully for small parts, which may have some loose inside the carton during shipment.

ASSEMBLY INSTRUCTIONS

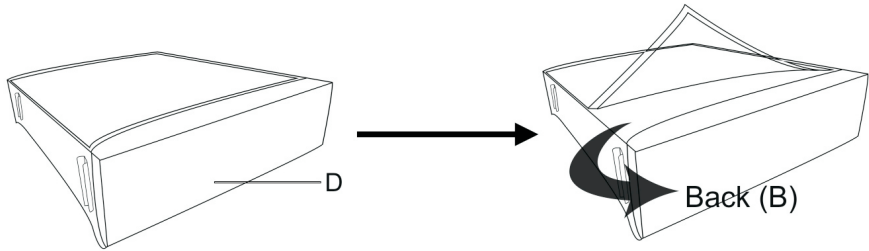

Remove the Velcro at the bottom of the armrest
and remove the Back (B) from inside

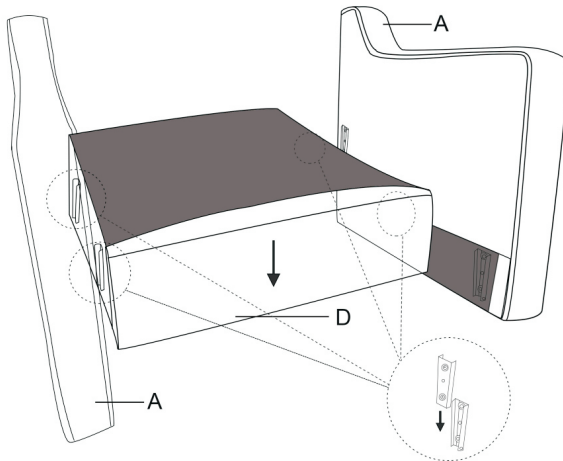

STEP 1: Attach seat(D) to sides(A),
Insert both connectors at the same time, Push hard to connect fully.

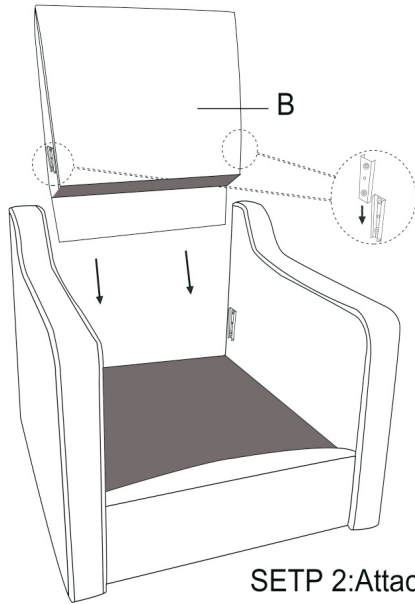

STEP 2: Attach back(B) to (A)&(D),
Insert both connectors at the same time,
Push hard to connect fully.

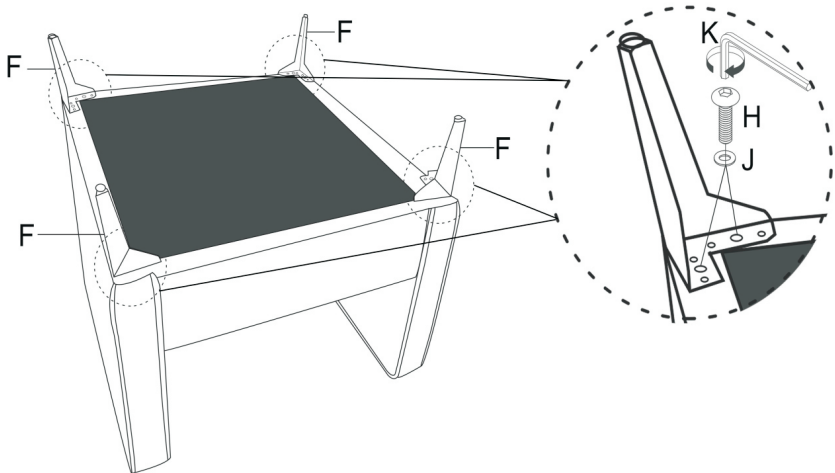

STEP 3: Attach legs(F) to bottom of armrests with bolts (H) ,washer(J) and allen key(K).

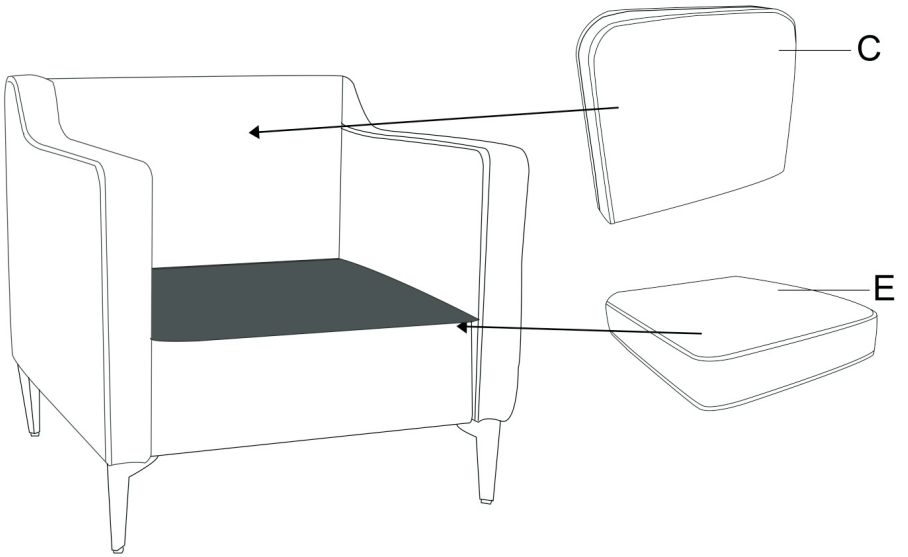

STEP 4: Place place seat pillow(E) on seat and then place back pillow(C) onto backrest.

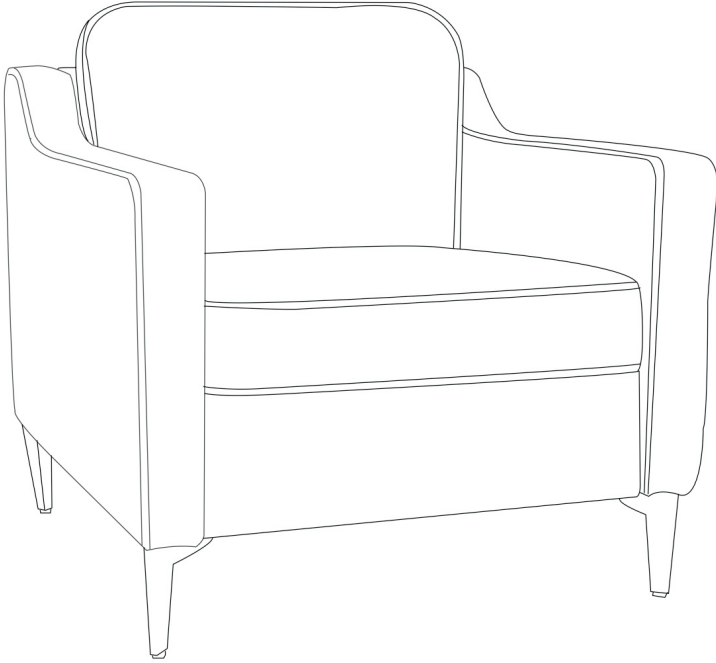

It will take a while for the cushions to expand. Normally it will take up to around 24 hours to expand to its full size.



If it is too wrinkled, please iron it with an ironer on low heat