







ASSEMBLY INSTRUCTION & PARTS IDENTIFICATION

Thank you for purchasing this quality product. Be sure to check all packing material carefully for small parts that may have come loose inside the carton during shipment.

Hardware Kit			
No		Description	Qty
A		Bolt M6x50mm Sheft Bolt	6 Pcs
B		Bolt M6x40mm Top Bolt	10 Pcs
C		Lock Washer	16 Pcs
D		Flat Washer	16 Pcs
E		Allen key	1 Pc
F		Dowel	8 Pcs

Key Parts			
No	Code	Description	Qty
1	a	STORAGE BOX	1 Pc
2	b	LEG ASSEMBLY	2 Pcs
3	c	SHELF	1 Pc
4	d	DRAWER COMPLETE	1 Pc
5	e	PULL W/ SCREW	1 Set
6	f	FULL EXTENSION GLIDE	1 Set
7	g	FLOOR GLIDE	4 Pcs

STEP 1:

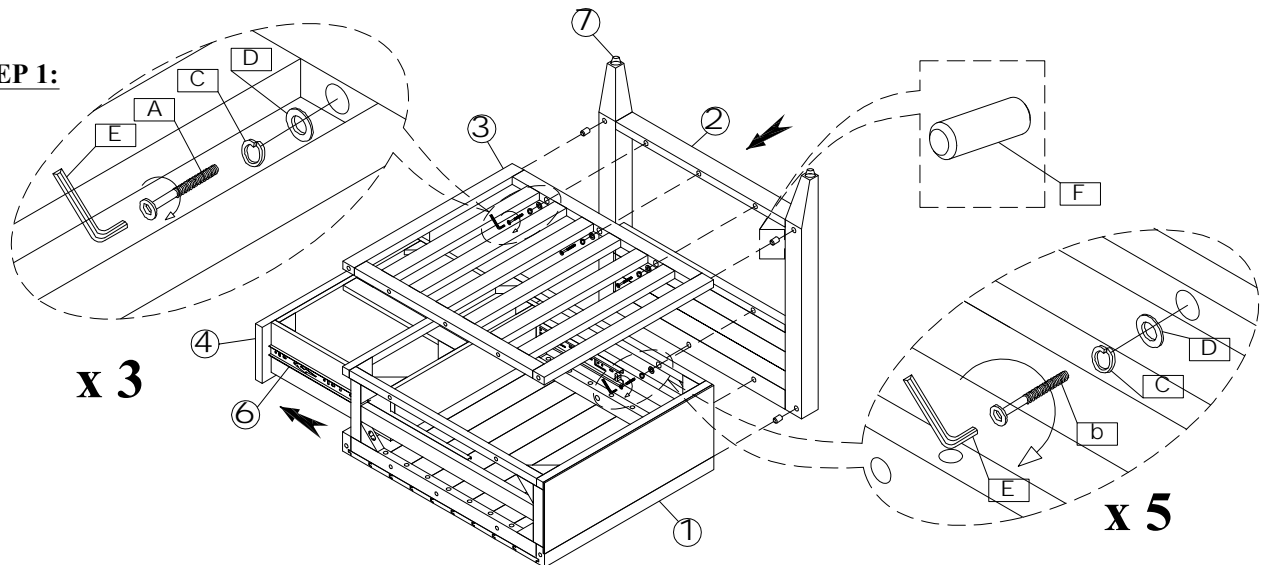



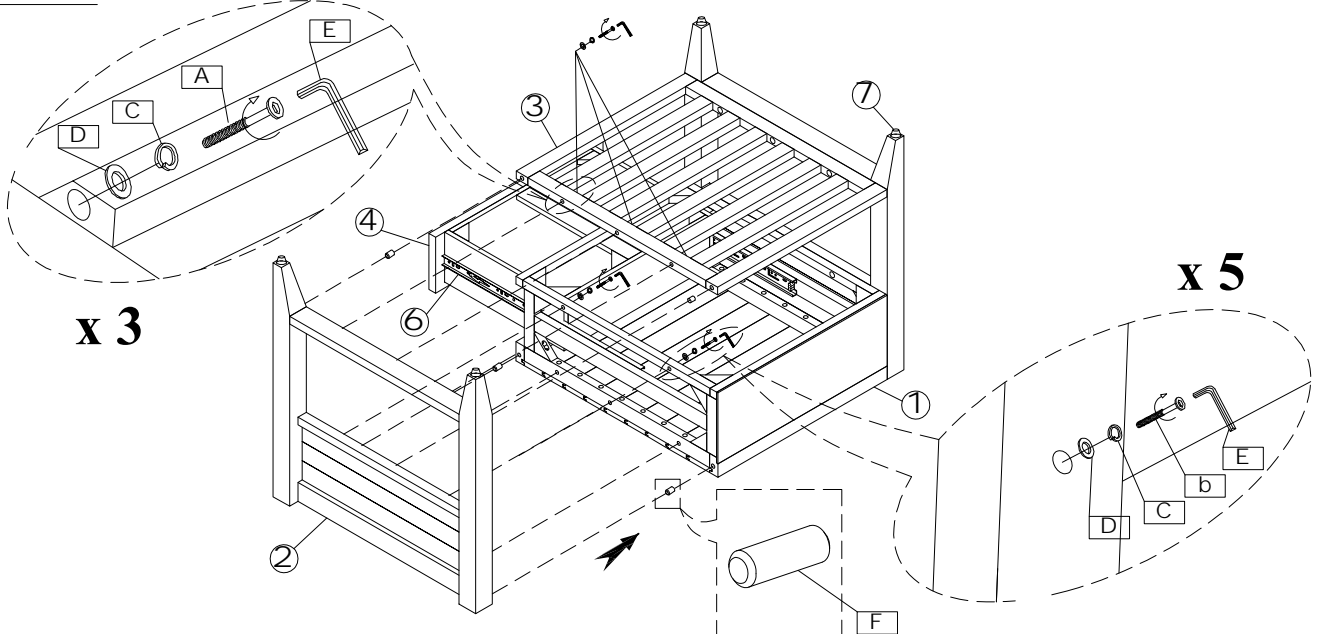



STEP 2:



ASSEMBLY INSTRUCTION & PARTS IDENTIFICATION END TABLE

Thank you for purchasing this quality product. Be sure to check all packing material carefully for small parts that may have come loose inside the carton during shipment.

Hardware Kit				Key Parts			
No	Description		Qty	No	Code	Description	Qty
A		Bolt M6x50mm Sheft Bolt	6 Pcs	1	a	STORAGE BOX	1 Pc
B		Bolt M6x40mm Top Bolt	10 Pcs	2	b	LEG ASSEMBLY	2 Pcs
C		Lock Washer	16 Pcs	3	c	SHELF	1 Pc
D		Flat Washer	16 Pcs	4	d	DRAWER COMPLETE	1 Pc
E		Allen key	1 Pc	5	e	PULL W/ SCREW	1 Set
F		Dowel	8 Pcs	6	f	FULL EXTENSION GLIDE	1 Set
				7	g	FLOOR GLIDE	4 Pcs

STEP 3:

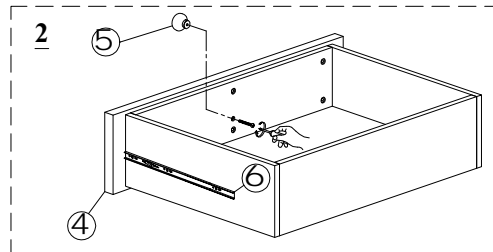
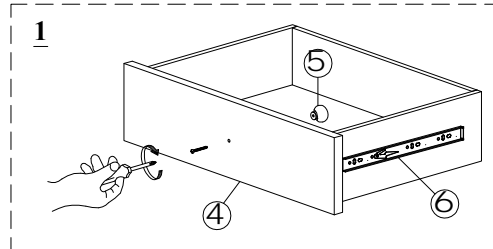
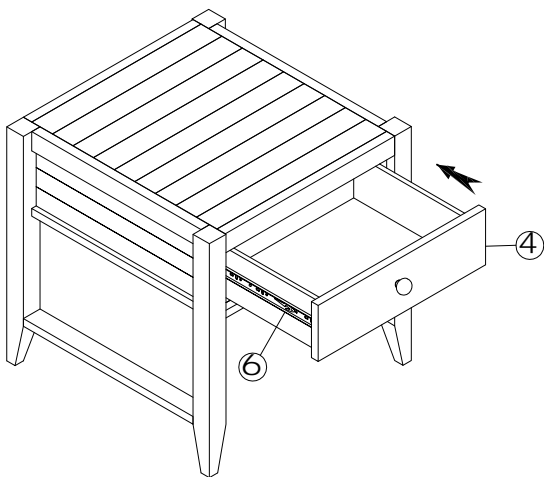

STEP 4:

