

Assembly Instructions

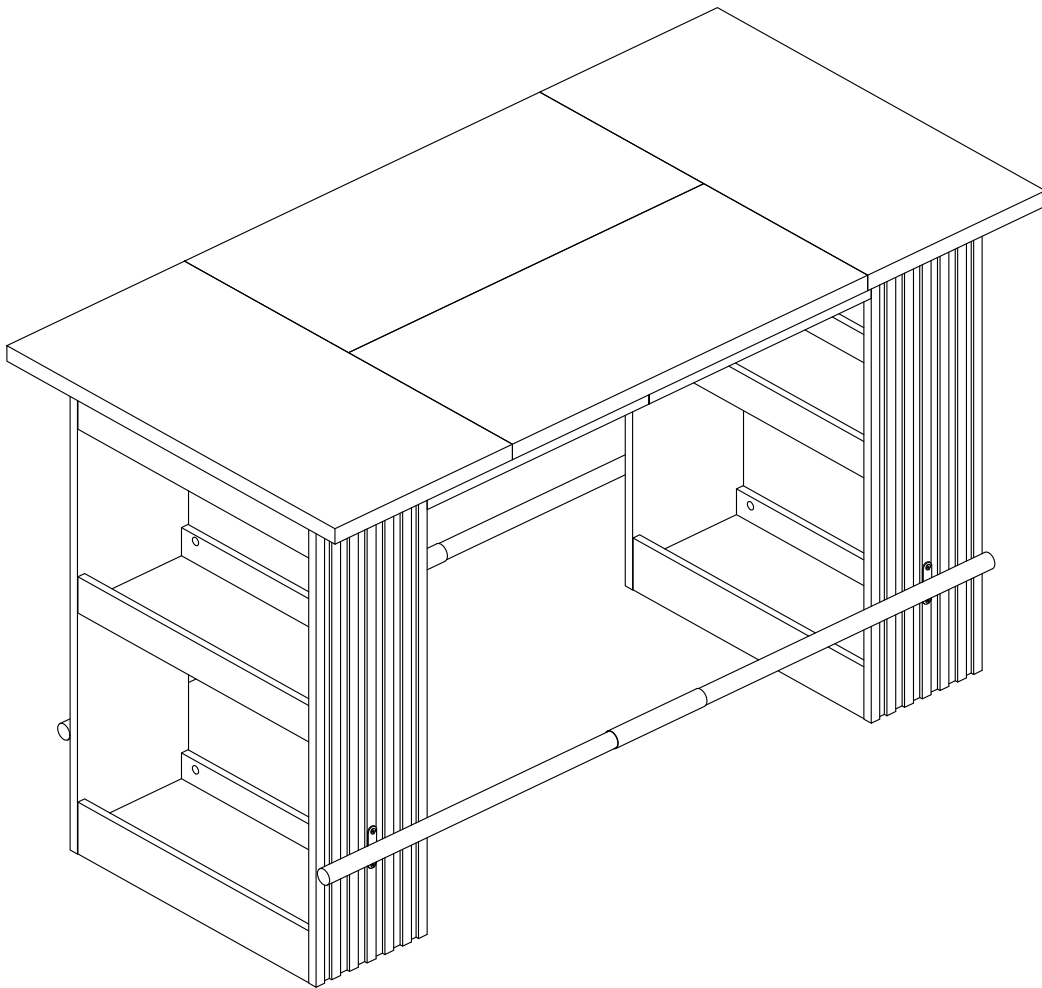

Bar Table

Model No.
HOGA-YT0020

Contact Us

We're here to help you.

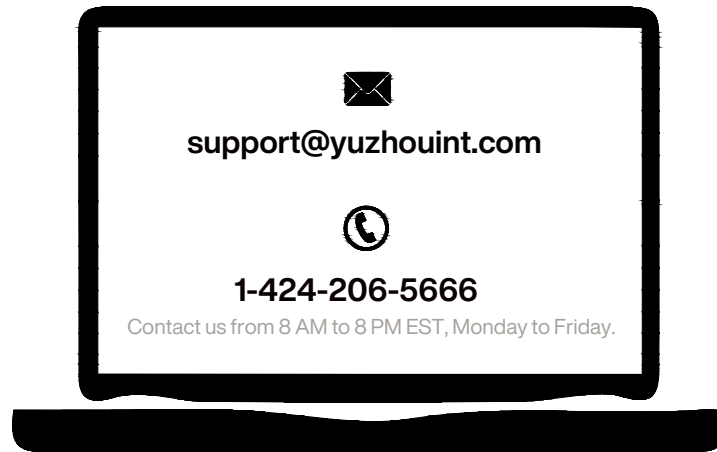

Your satisfaction is our top priority. If you encounter any issues with this product, such as missing or damaged parts, we're here to help. Please retain the original packaging and take photos of the packaging and the product, then contact us as soon as possible.

Warm Tips

1. Carefully read these instructions and keep them for future reference.
2. Check the parts list and confirm everything's there before starting assembly.
3. When assembling, put all parts on a soft, smooth surface like a carpet to avoid scratches.
4. Don't fully tighten screws until all parts are confirmed in place to avoid misalignment.

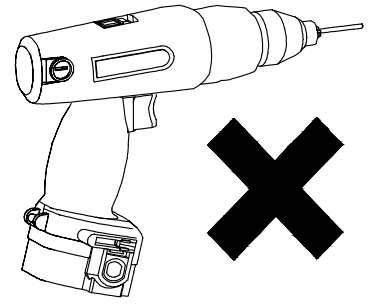
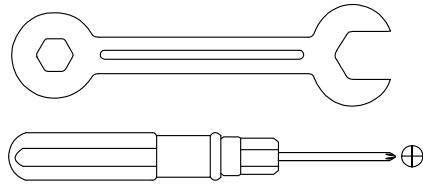
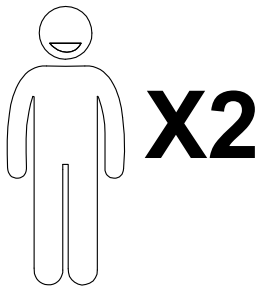

We recommend using hand tools for assembly.

If an electric screwdriver is used, reduce power and torque to avoid damage to the product.

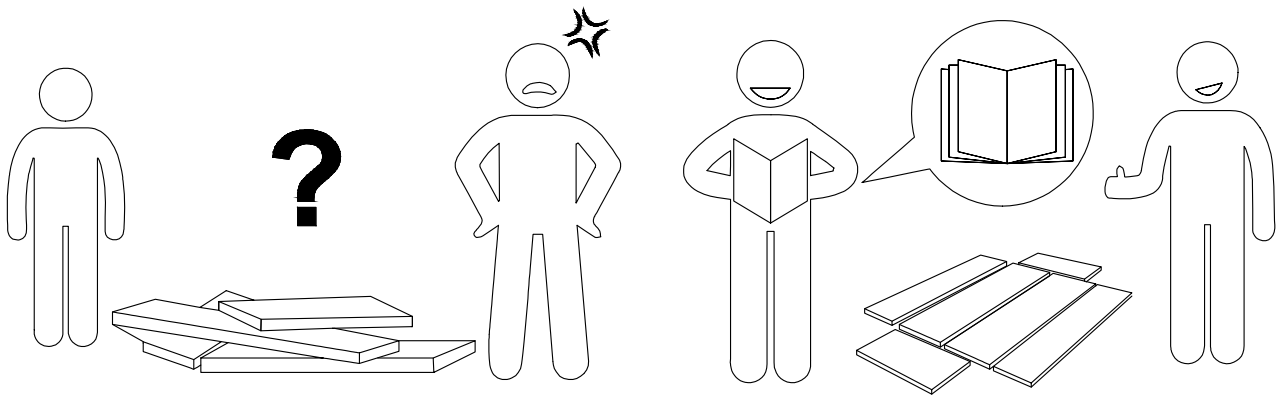

AVOID SCRATCHES

In order to avoid scratching, this furniture should be assembled on a soft surface, such as a rug.

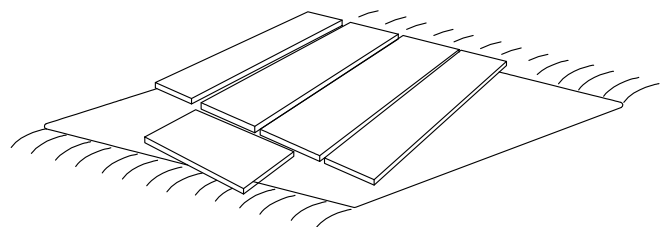
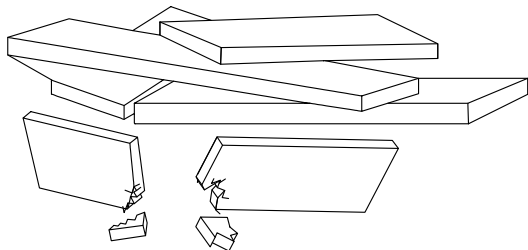

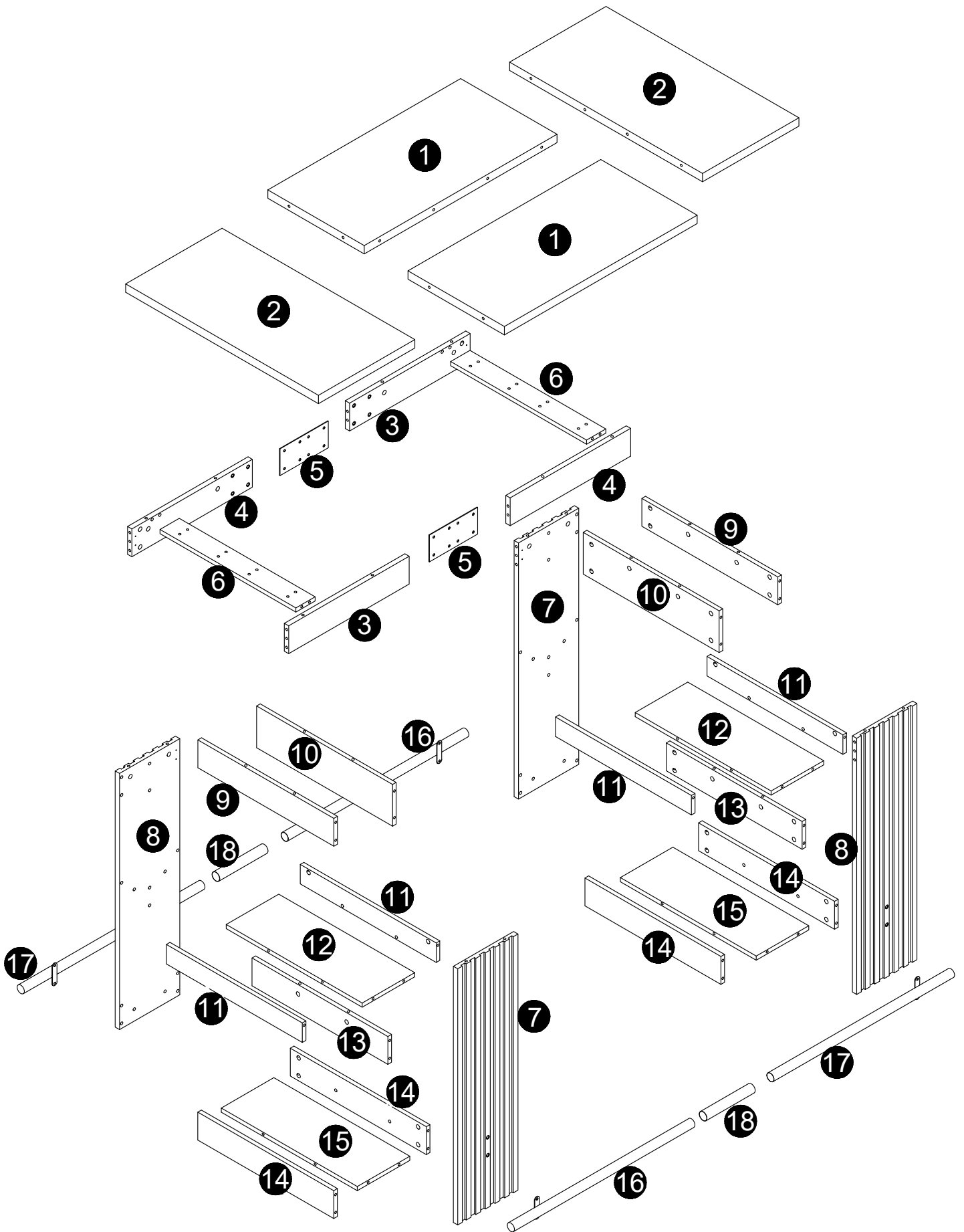

⚠ Caution

Make sure all parts are included. Most board parts are labeled or stamped on the raw edge. Contact us for a free replacement if you encounter any damaged or missing parts.



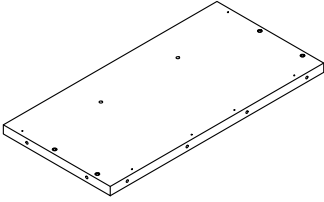
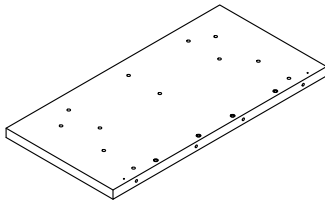
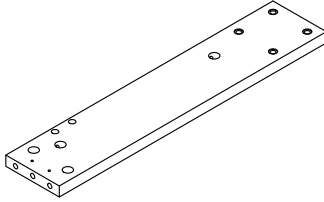
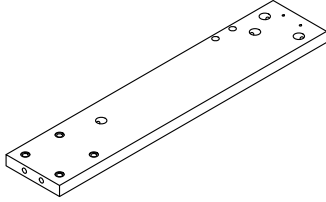
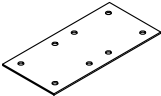
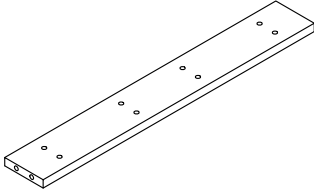
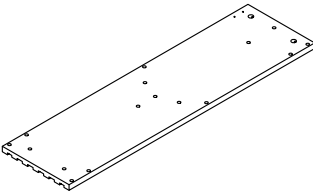
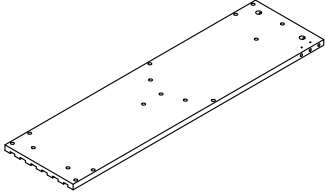
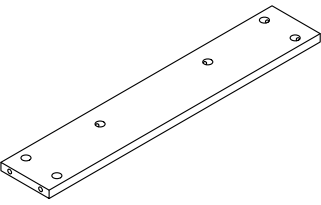
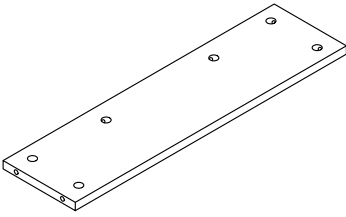
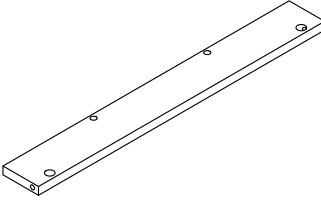
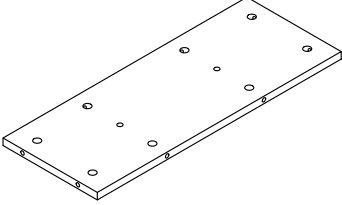
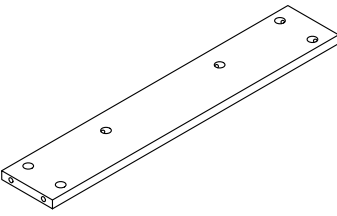
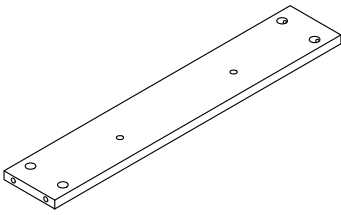
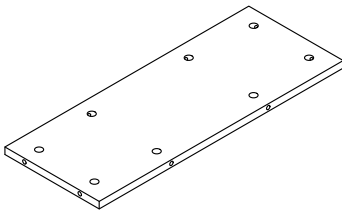
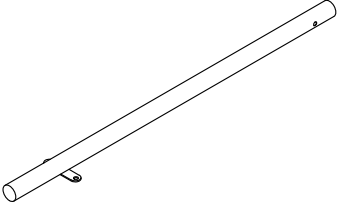

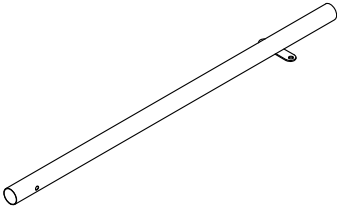
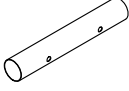

Parts List

1  2 pcs	2  2 pcs	3  2 pcs	4  2 pcs
5  2 pcs	6  2 pcs	7  2 pcs	8  2 pcs
9  2 pcs	10  2 pcs	11  4 pcs	12  2 pcs
13  2 pcs	14  4 pcs	15  2 pcs	16  2 pcs

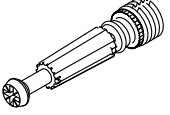
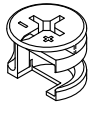
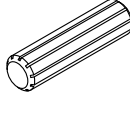
Parts List

<p>17</p>  <p>2 pcs</p>	<p>18</p>  <p>2 pcs</p>		
---	---	--	--

Hardware List

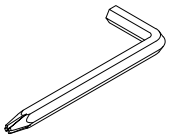
A	B	C	D	E	F
 <p>Ø6x40mm</p>	 <p>Ø15x12mm</p>	 <p>Ø8x30mm</p>	 <p>M6x25mm</p>	 <p>M6x12mm</p>	 <p>47x16x2mm</p>
<p>124 pcs</p>	<p>124 pcs</p>	<p>20 pcs</p>	<p>16 pcs</p>	<p>28 pcs</p>	<p>16 pcs</p>
G	H	I	J		
 <p>Ø3.5x14mm</p>	 <p>Ø21</p>		 <p>M4</p>		
<p>32 pcs</p>	<p>28 pcs</p>	<p>8 pcs</p>	<p>1 pc</p>		

Installation of Cams and Pins

Step 1-2: Align the plastic part with the mounting hole and press it in. If you can't press it in, loosen the screw counter clockwise or completely remove the screw from the plastic part and try again.

Step 3-4: After pressing the plastic part into place, use a screwdriver to tighten the screw clockwise.

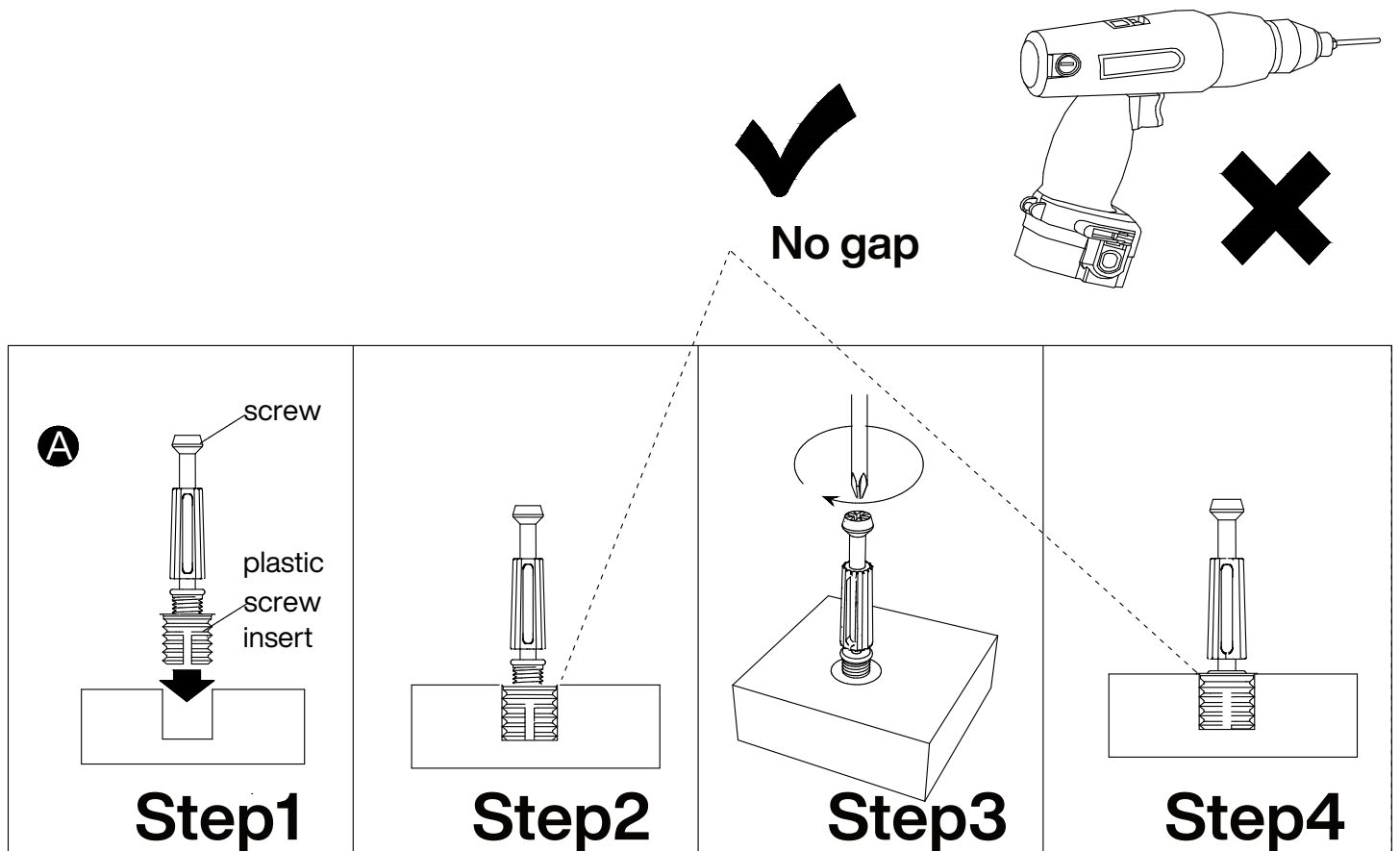

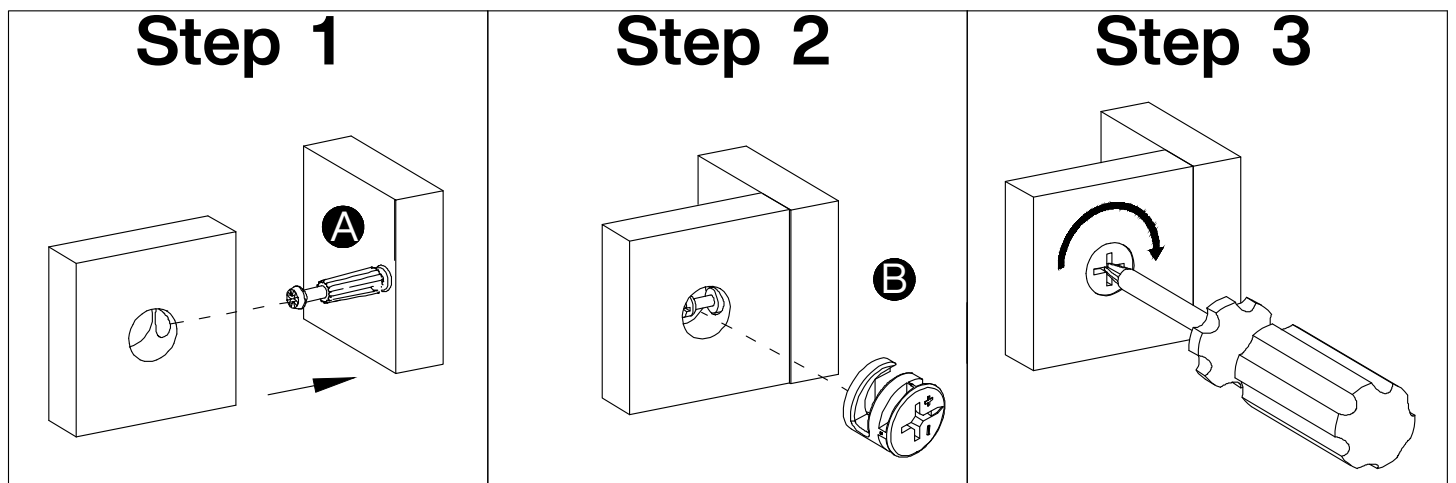

Screw the pin into the hole. Set the cams correctly by aligning the head of the cams with the lock pins. Lock the cam by turning the cam head with a screwdriver until it is tightened. Please do not use an electric screwdriver to assemble the unit.

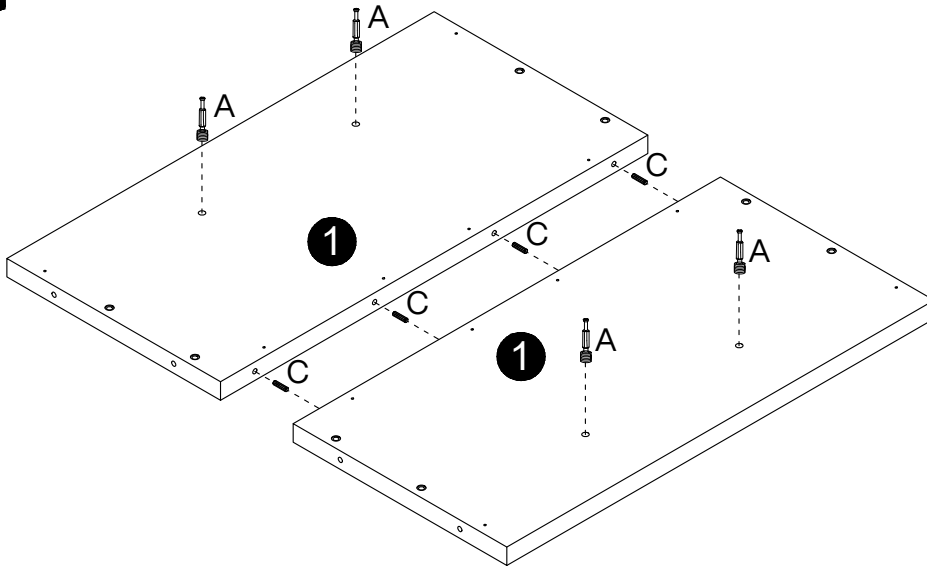

1

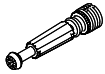

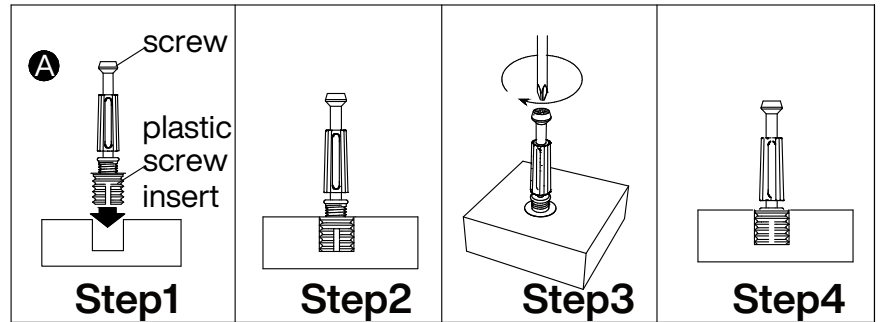

A	C
	
Ø6x40mm	Ø8x30mm
4 pcs	4 pcs



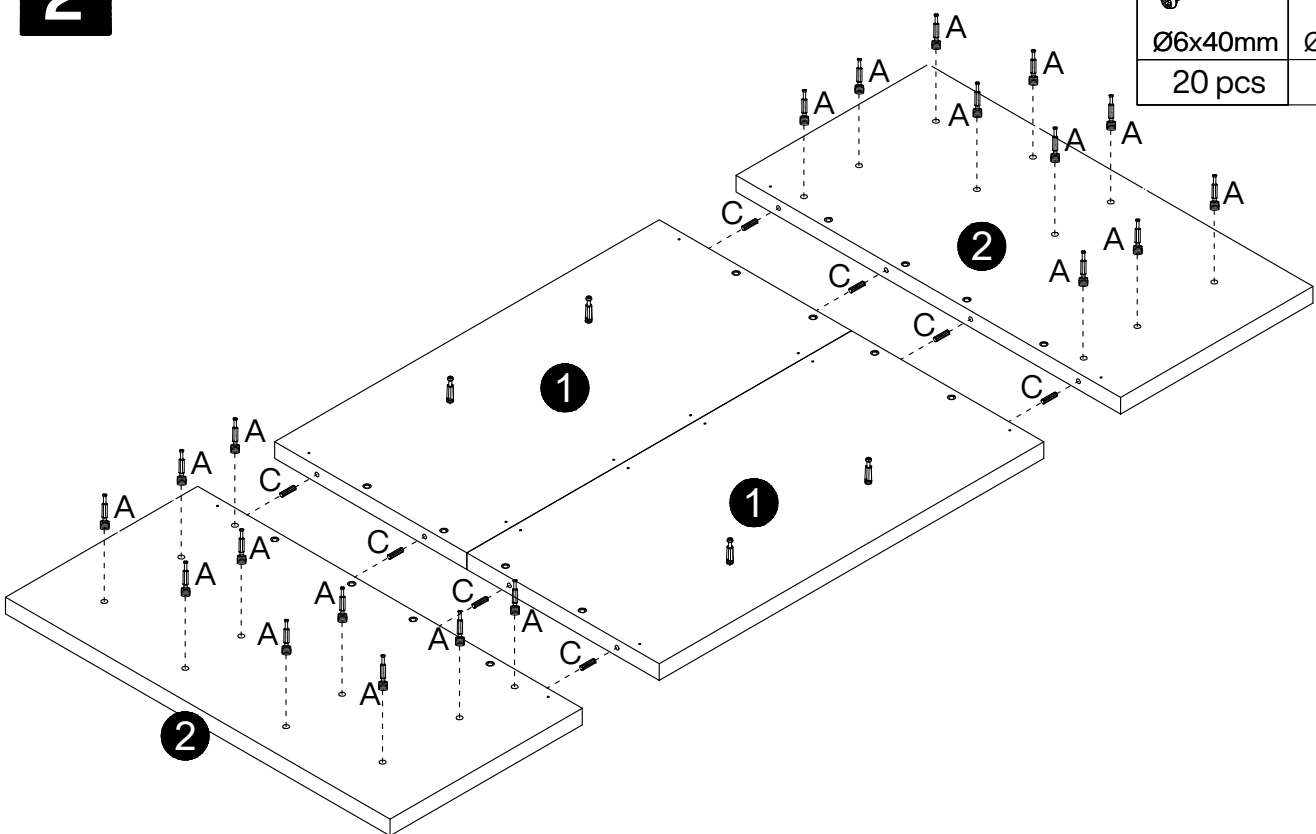

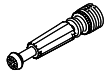
2



A	C
	
Ø6x40mm	Ø8x30mm
20 pcs	8 pcs

3

G	F
	
3.5x14mm	47x16x2mm
16 pcs	8 pcs

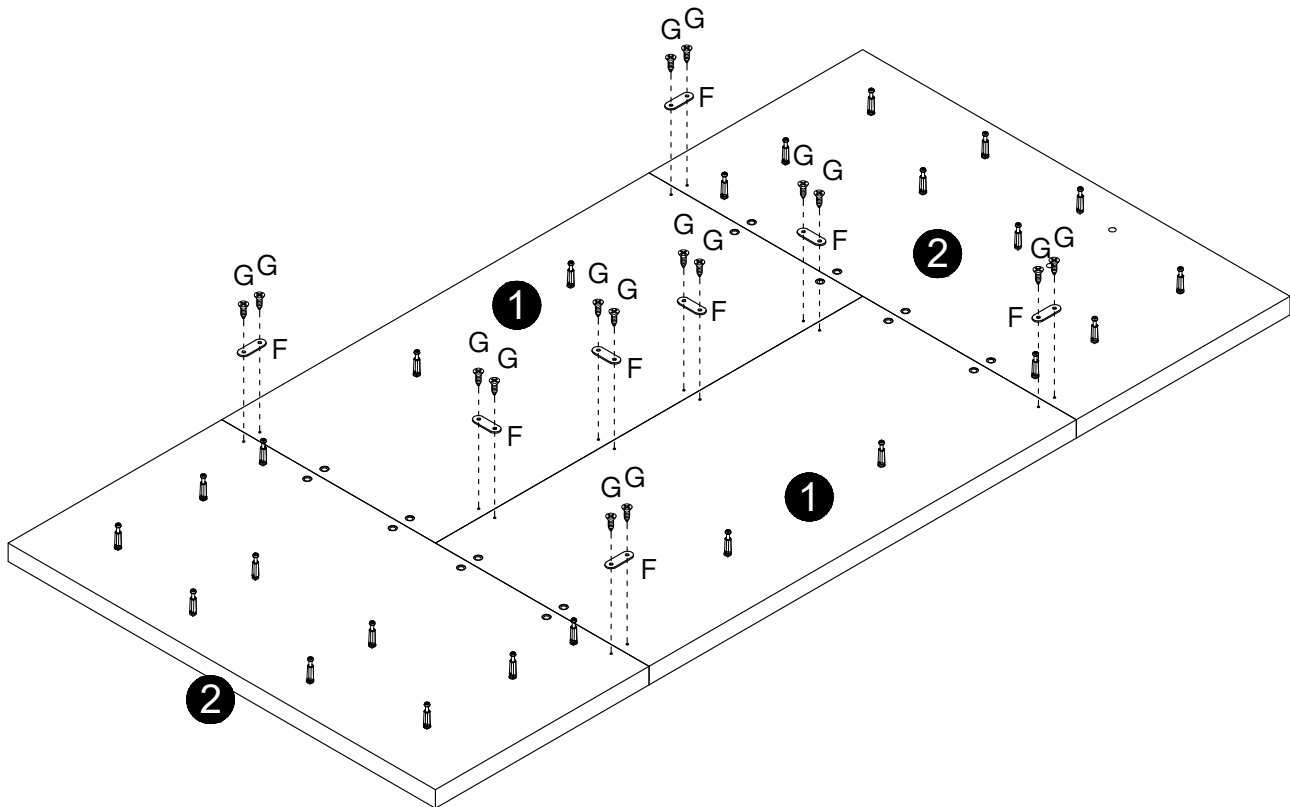

4

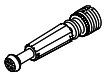
A

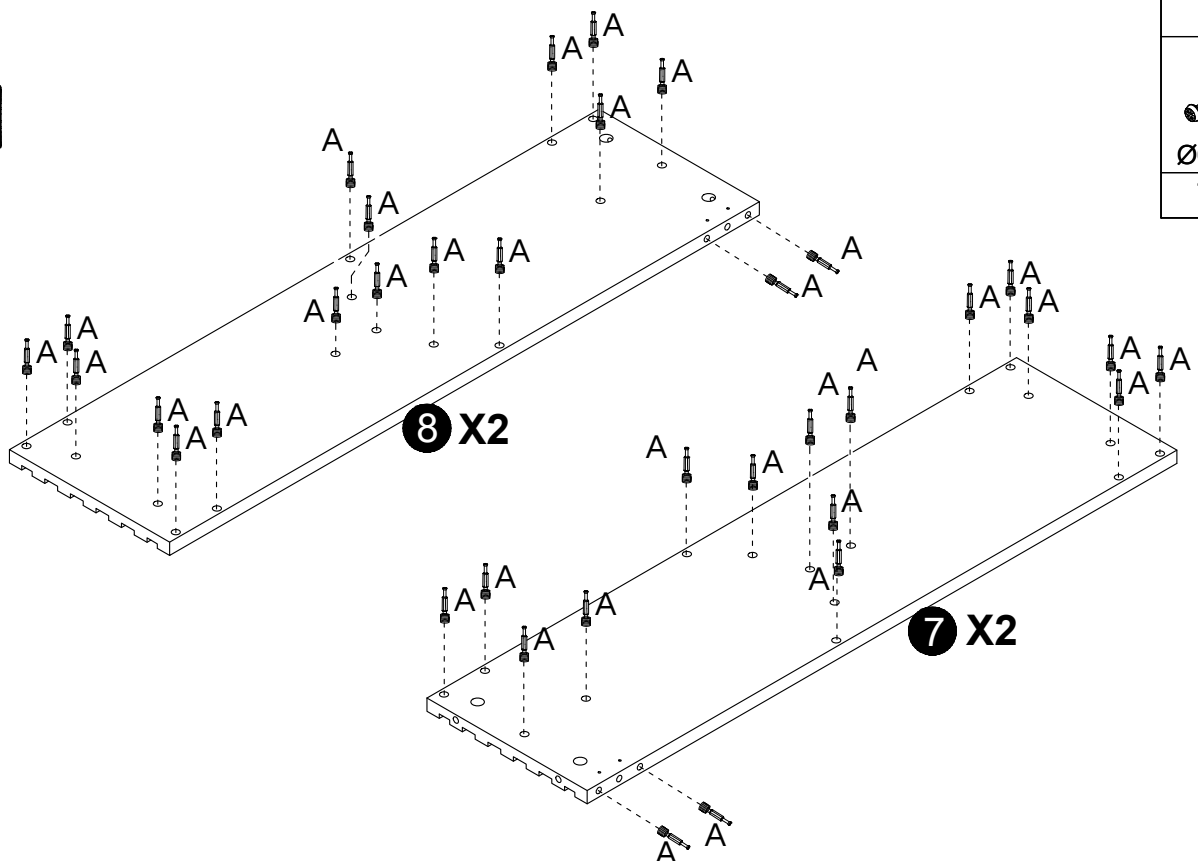
Ø6x40mm
72 pcs



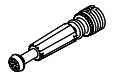

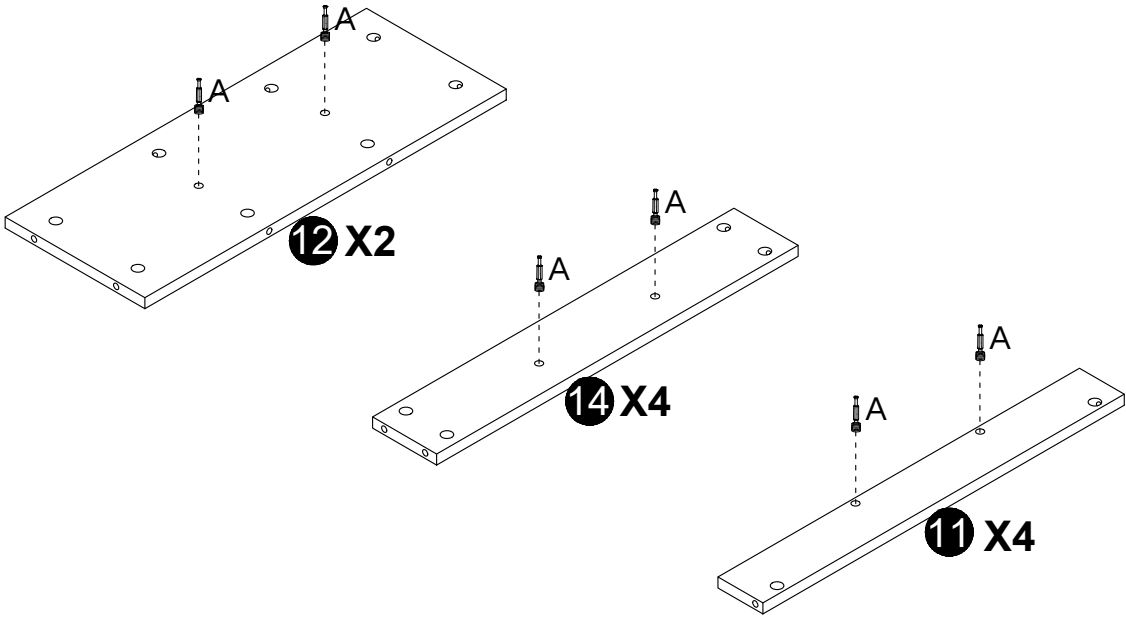

5

A

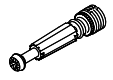
Ø6x40mm
20 pcs



6

A	C	E
		
Ø6x40mm	Ø8x30mm	M6x12mm
8 pcs	4 pcs	16 pcs

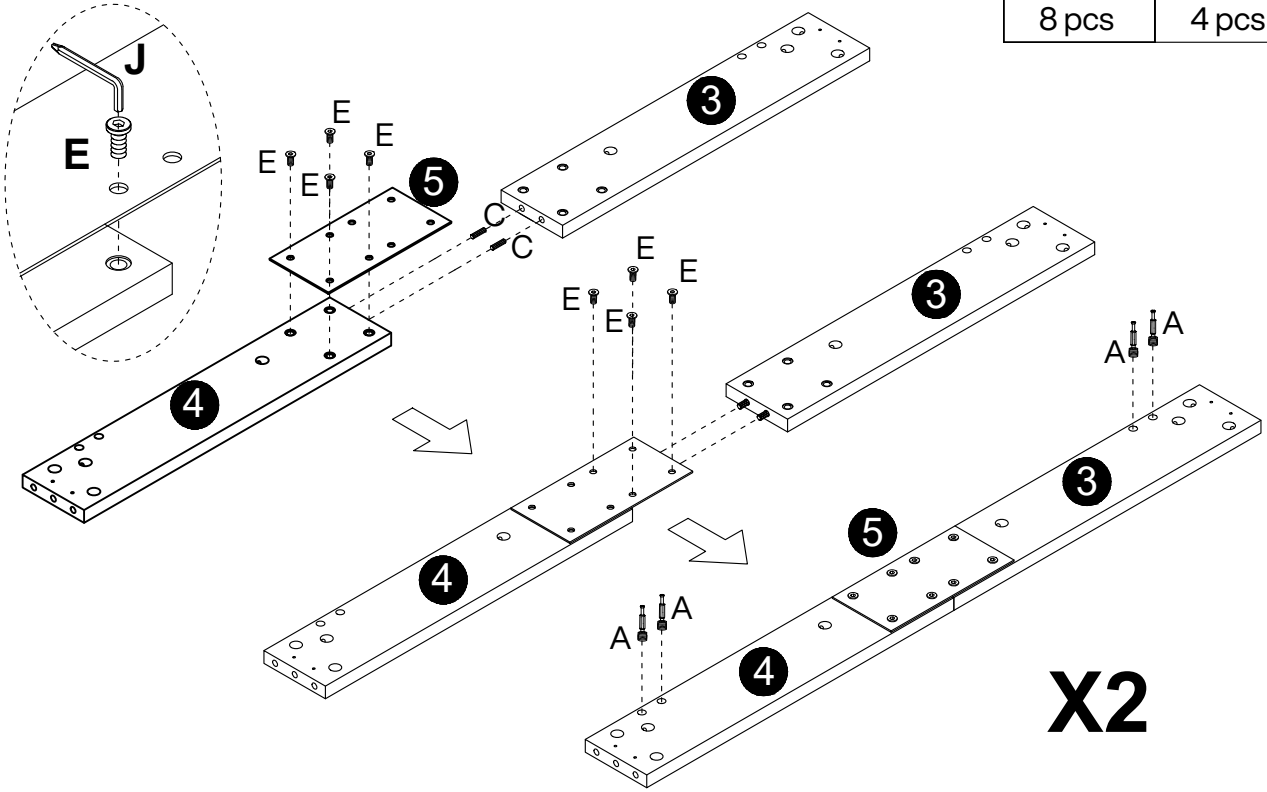
J

M4
1pc

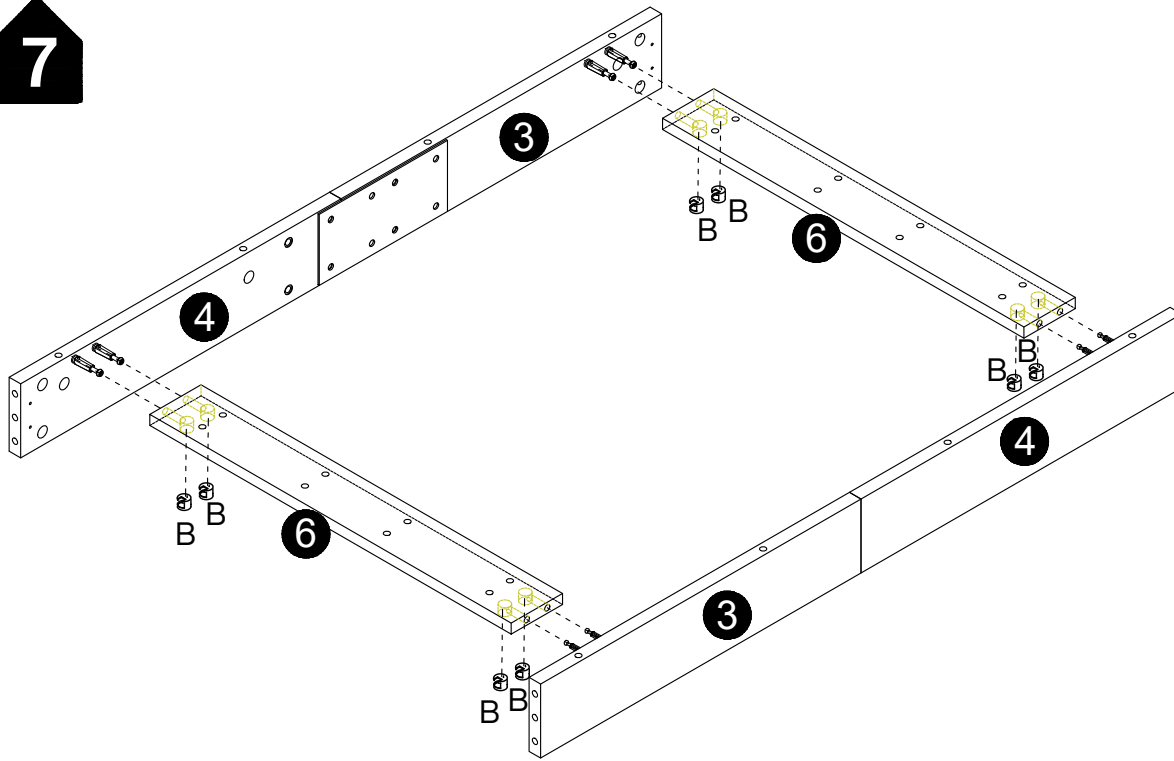

7

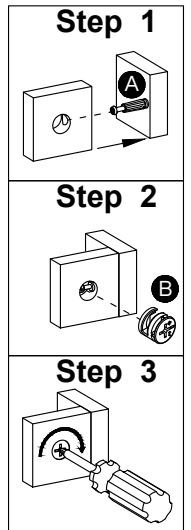

B

Ø15x12mm
8 pcs

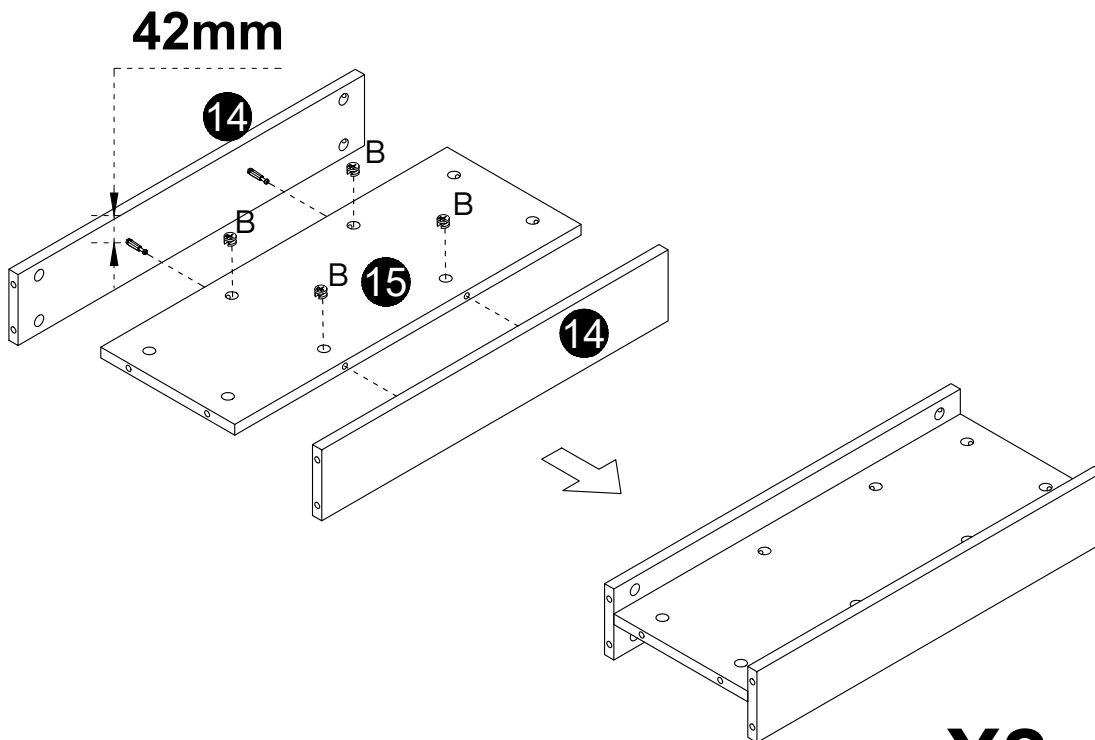

8



B

Ø15x12mm
8 pcs

X2

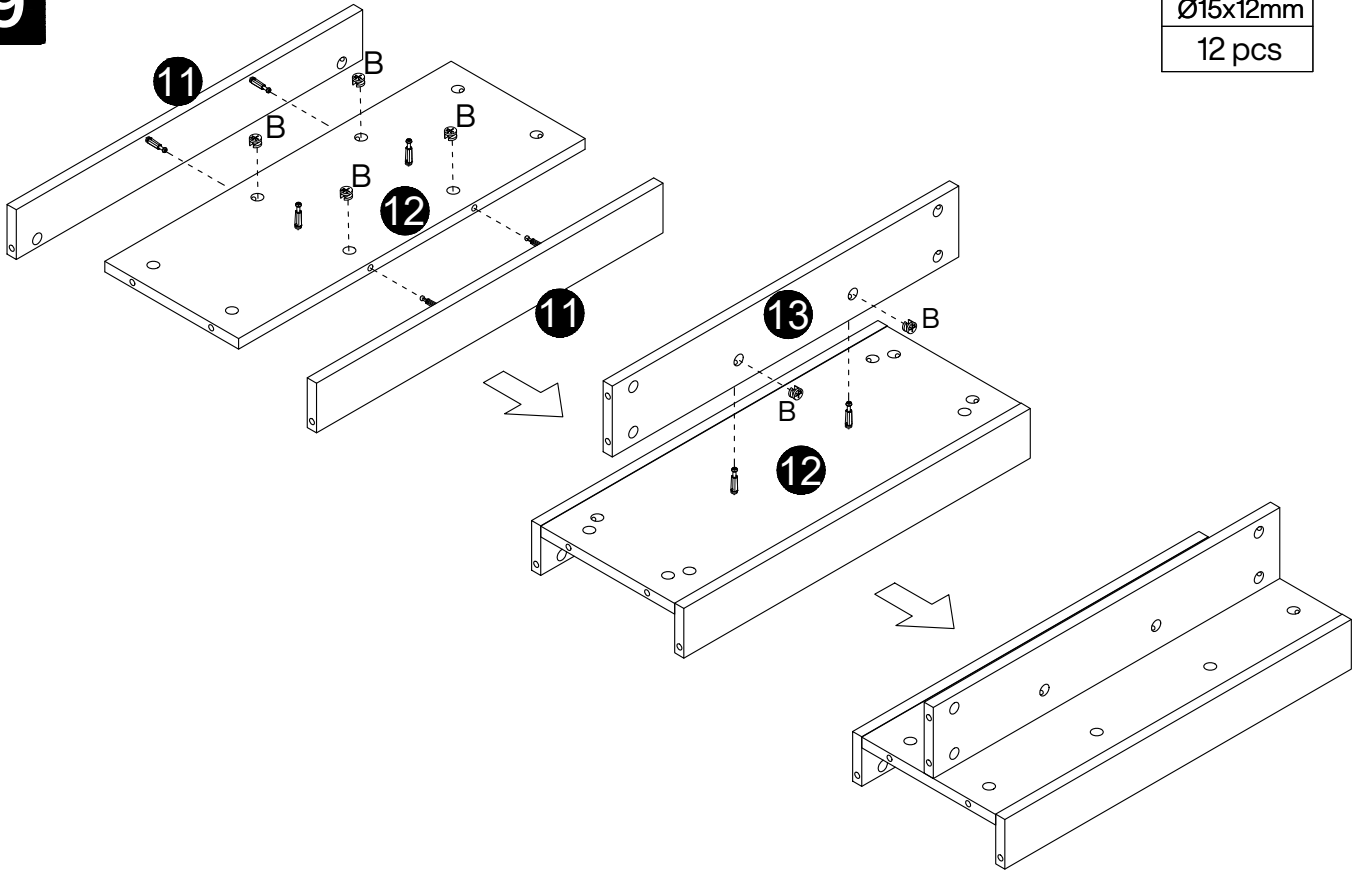
9





B

Ø15x12mm
12 pcs

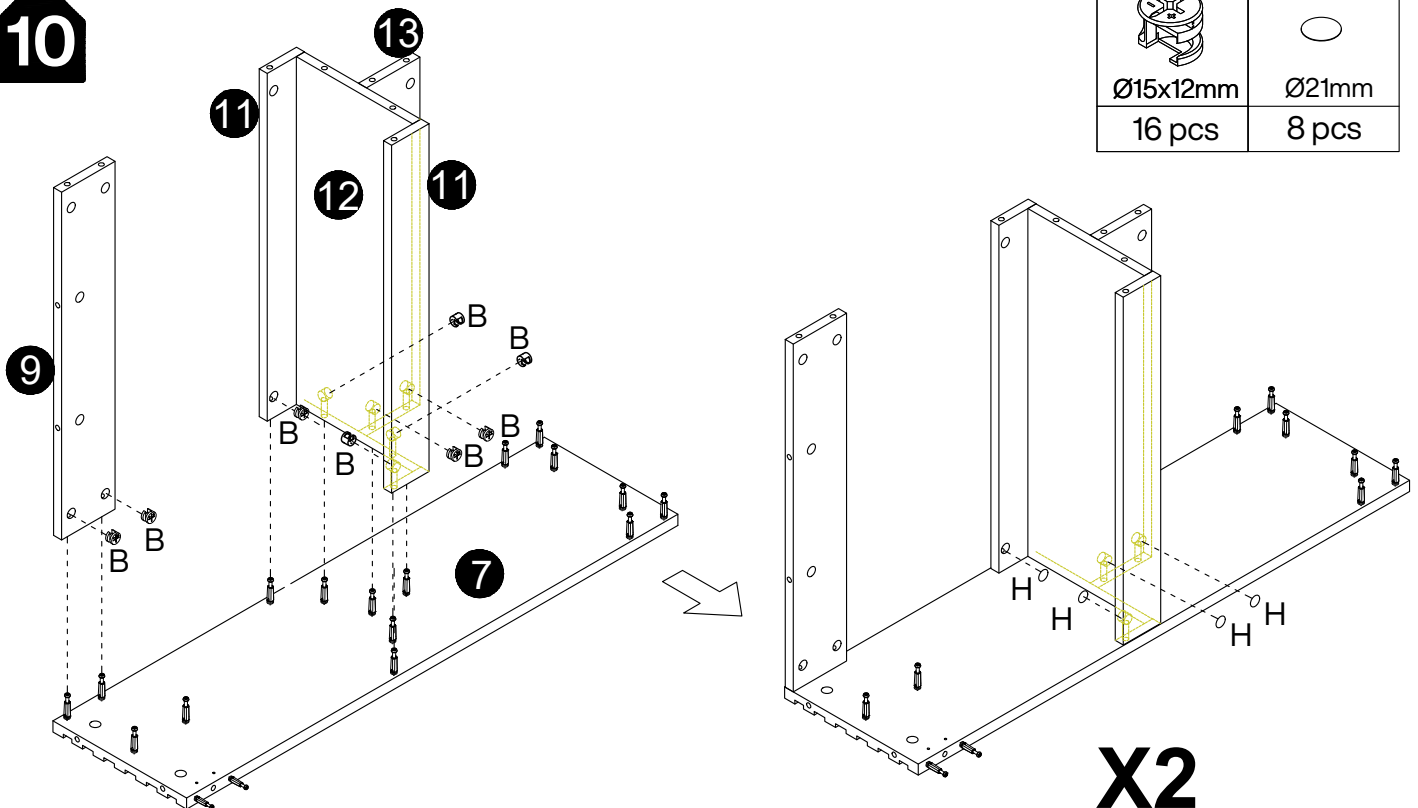
X2

10





B	H
	
Ø15x12mm	Ø21mm
16 pcs	8 pcs

X2

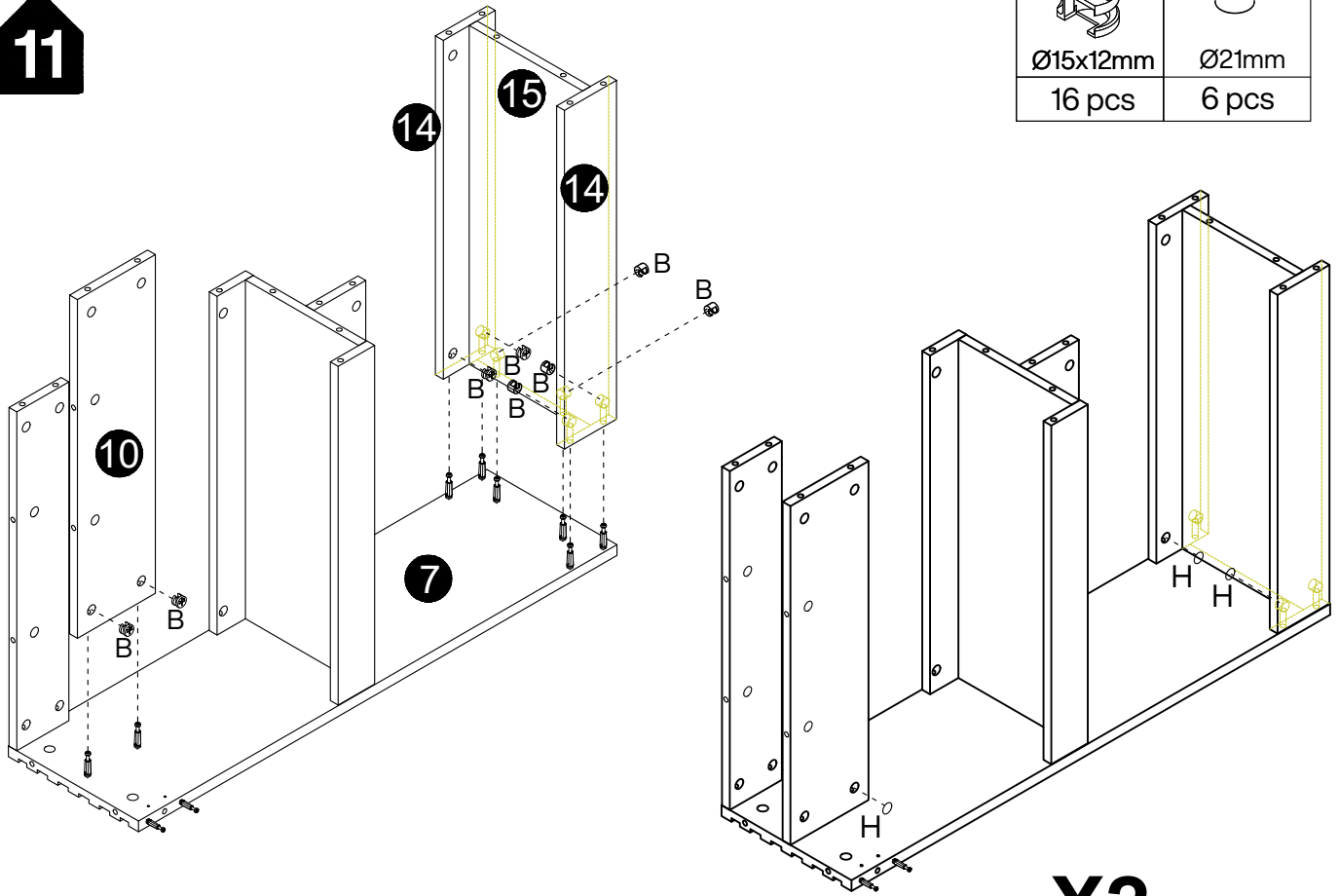
11





B	H
	
Ø15x12mm	Ø21mm
16 pcs	6 pcs

X2

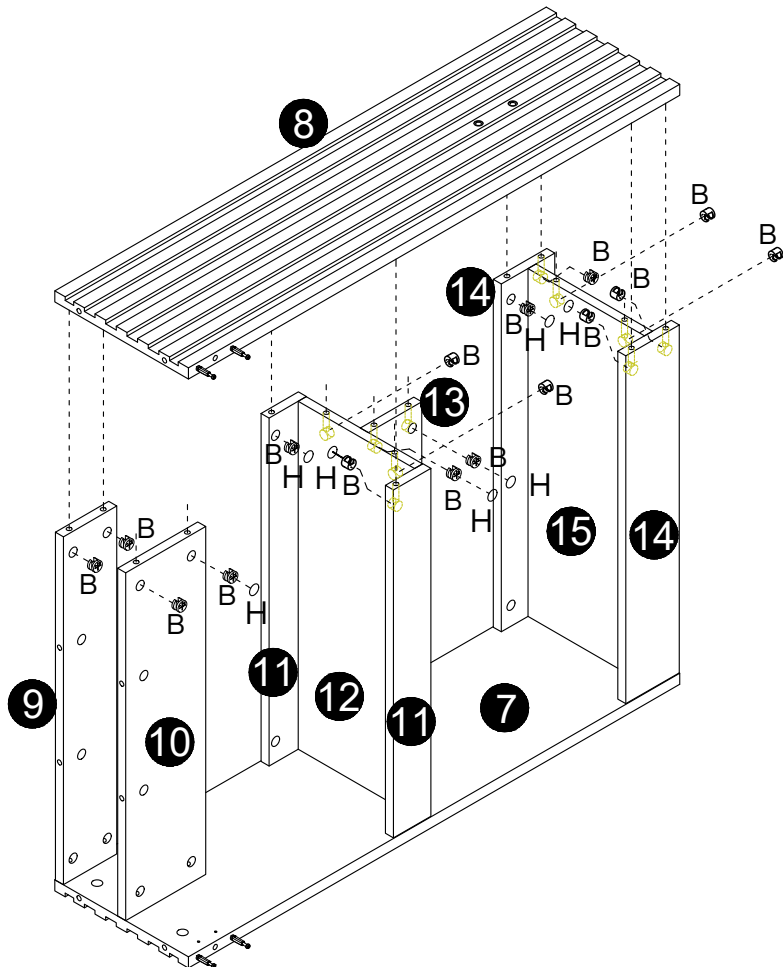
12



B	H
	
Ø15x12mm	Ø21mm
32 pcs	14 pcs

X2

13

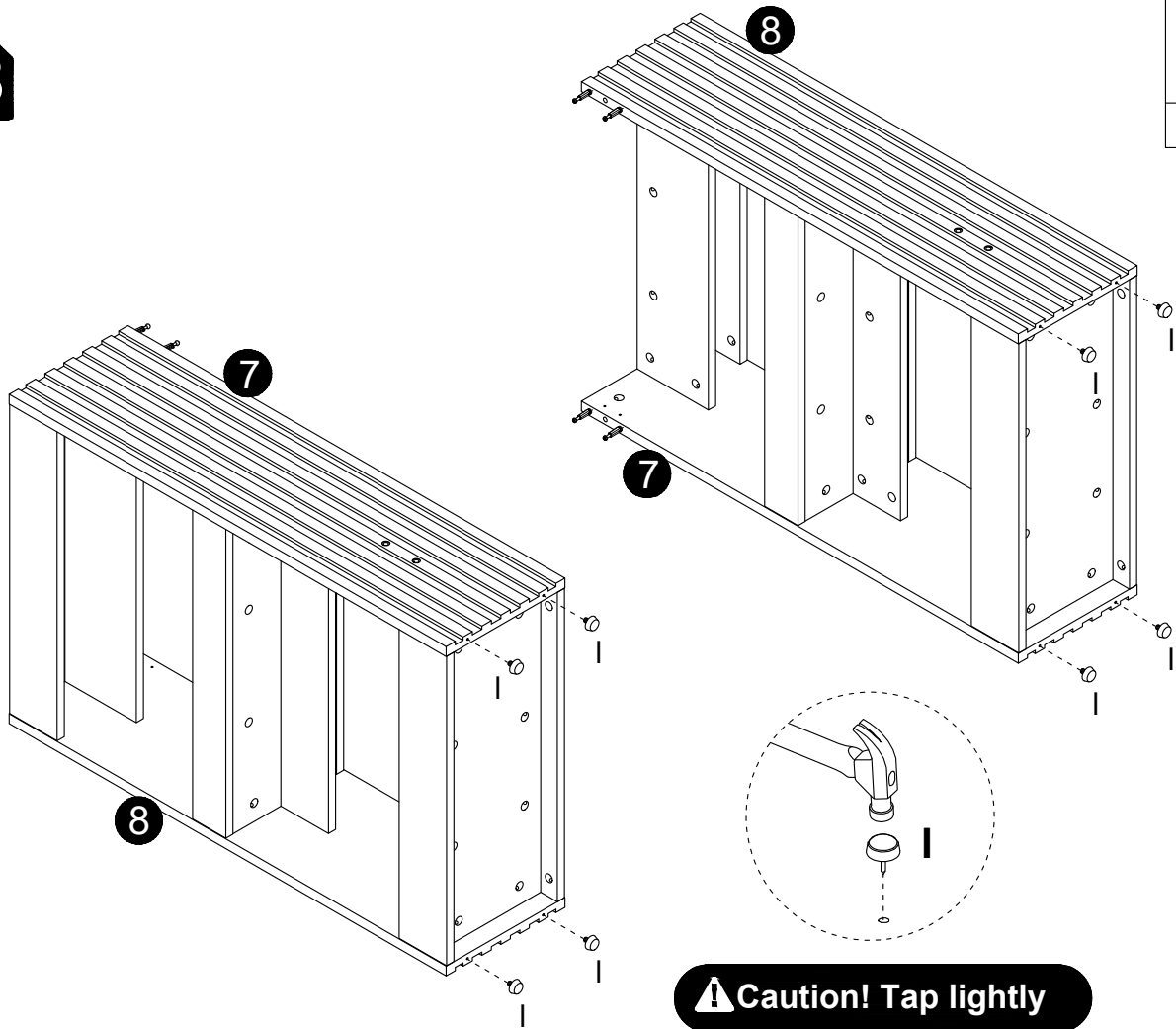



I

8 pcs

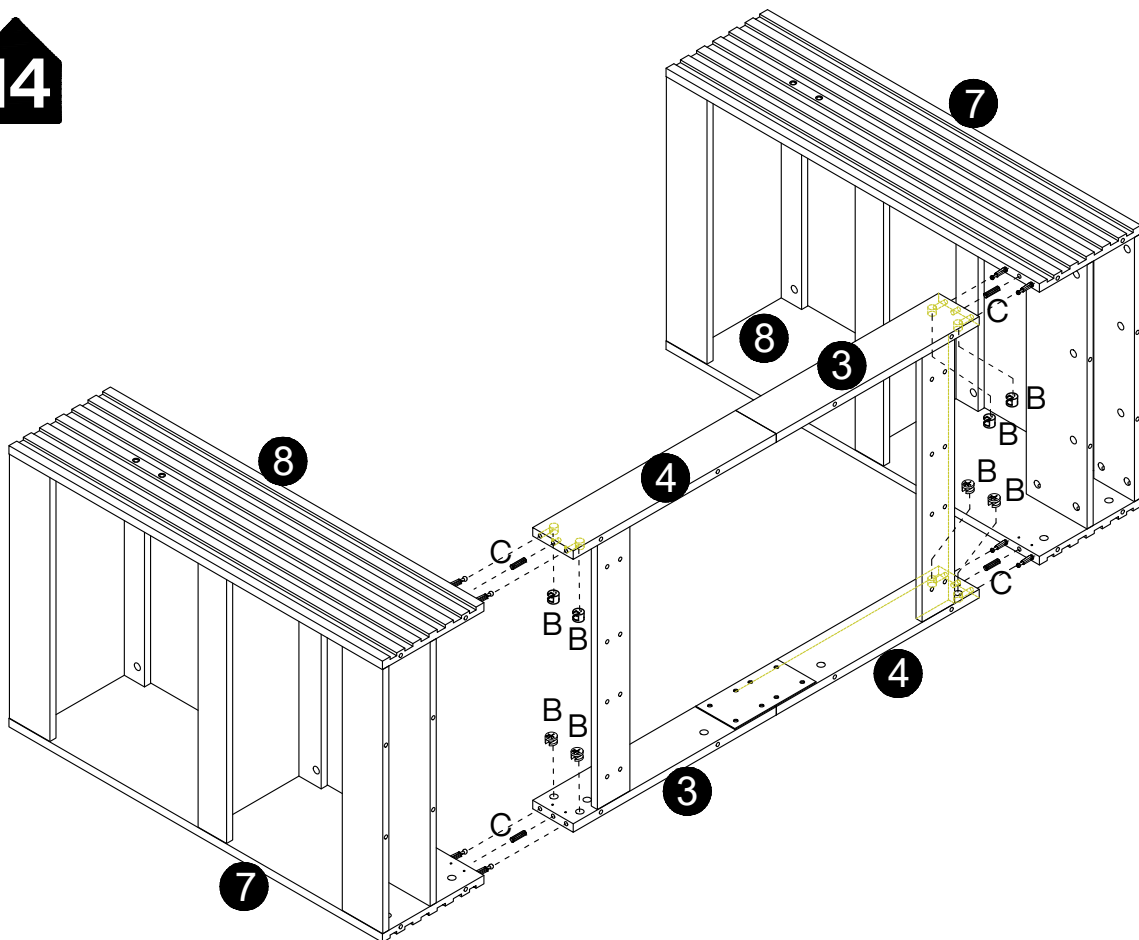
⚠ Caution! Tap lightly



14



B

Ø15x12mm
8 pcs

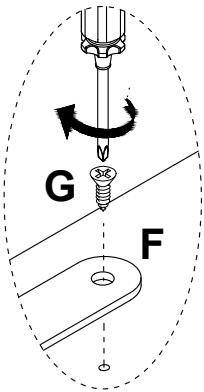
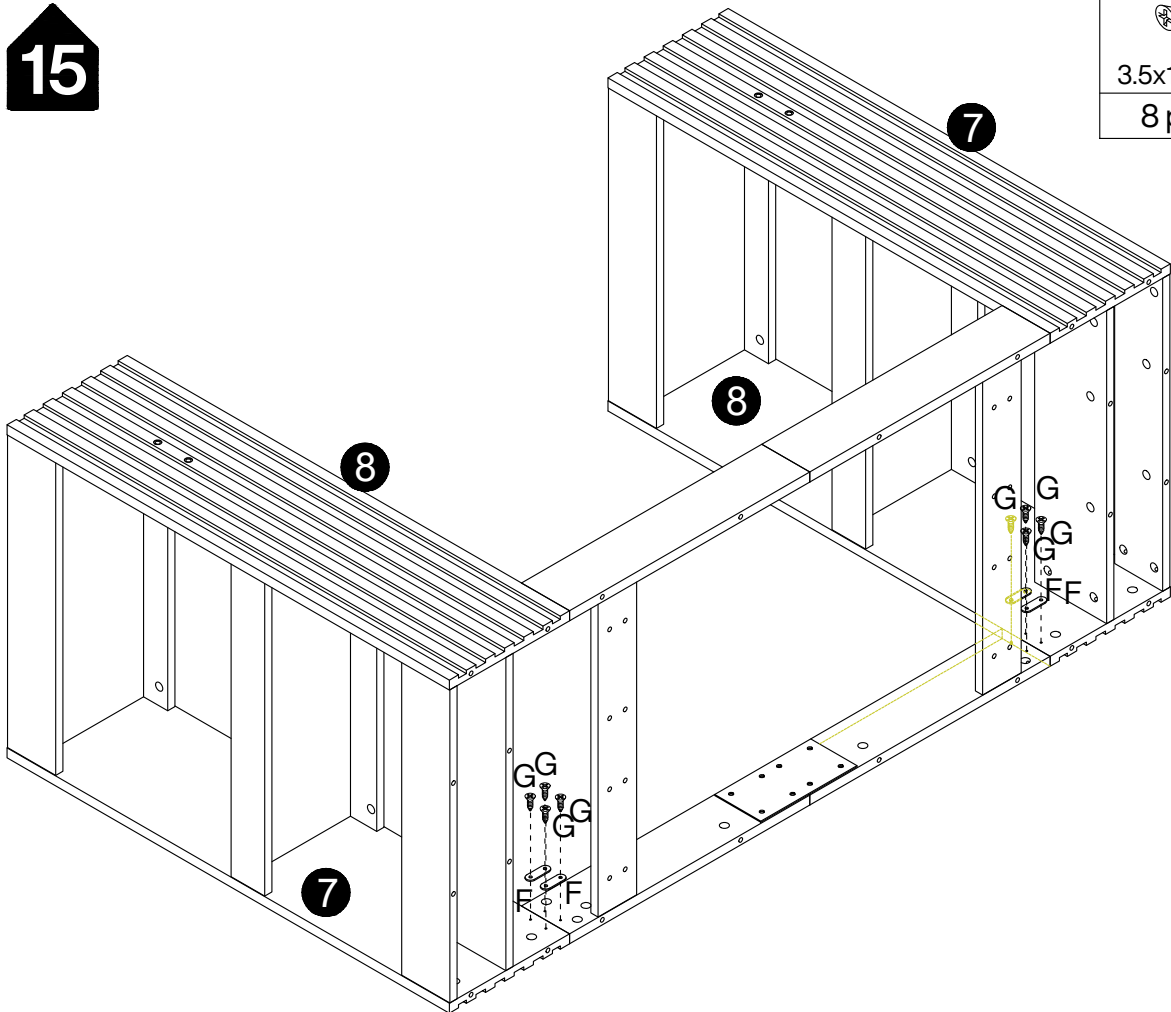

C

Ø8x30mm
4 pcs

15

G	F
	
3.5x14mm	47x16x2mm
8 pcs	4 pcs



16

G	F
	
3.5x14mm	47x16x2mm
8 pcs	4 pcs

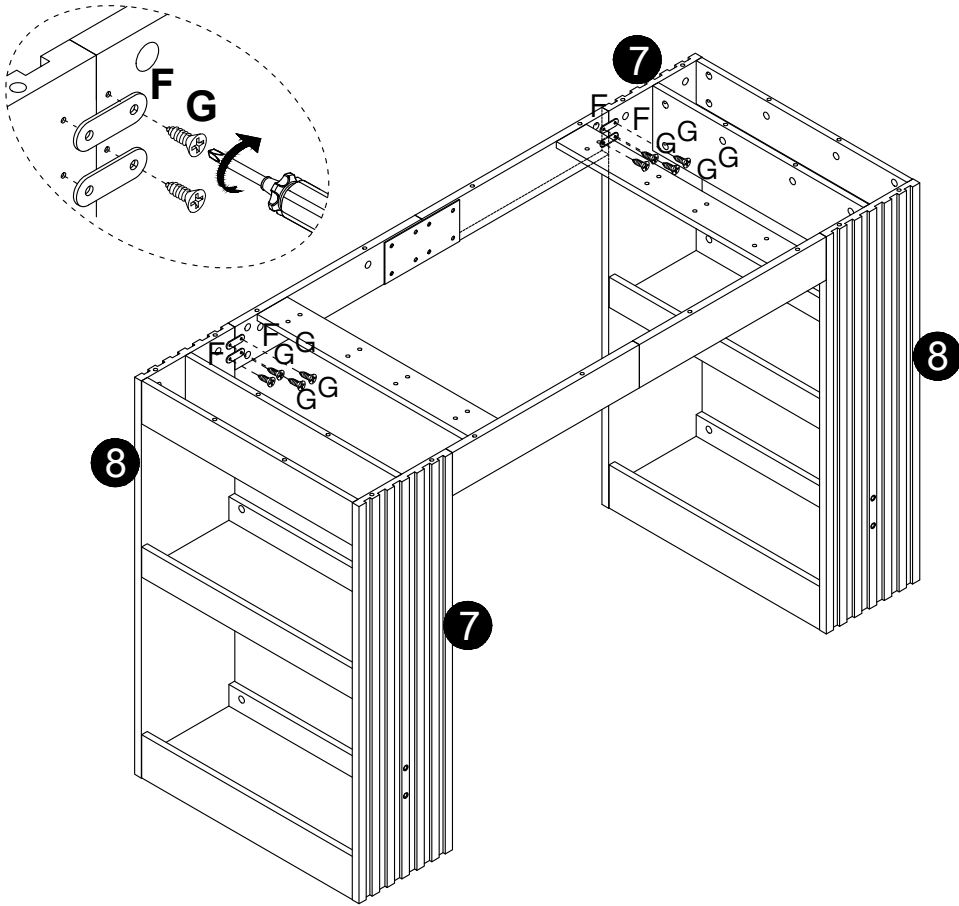

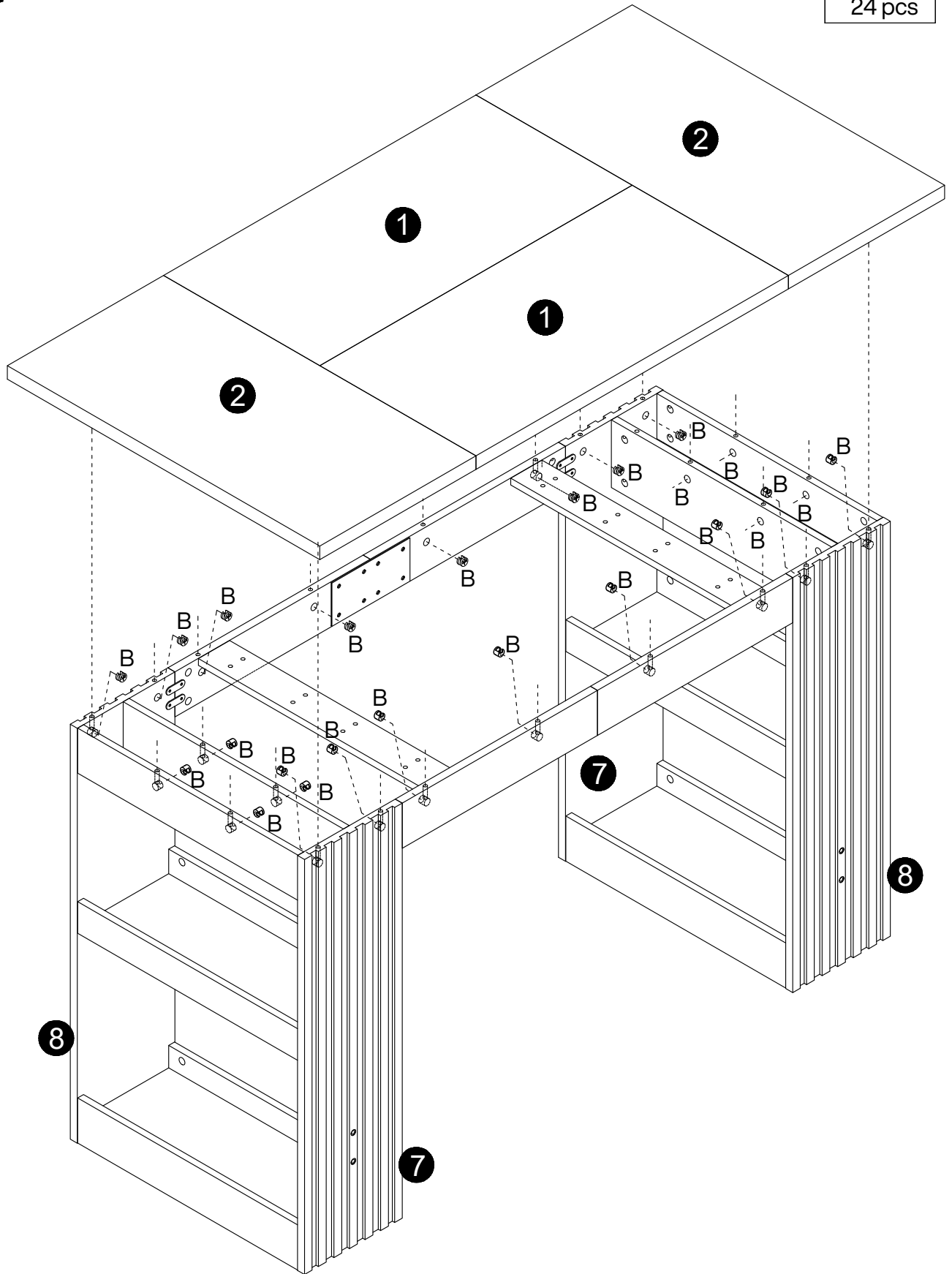

17

B

Ø15x12mm
24 pcs

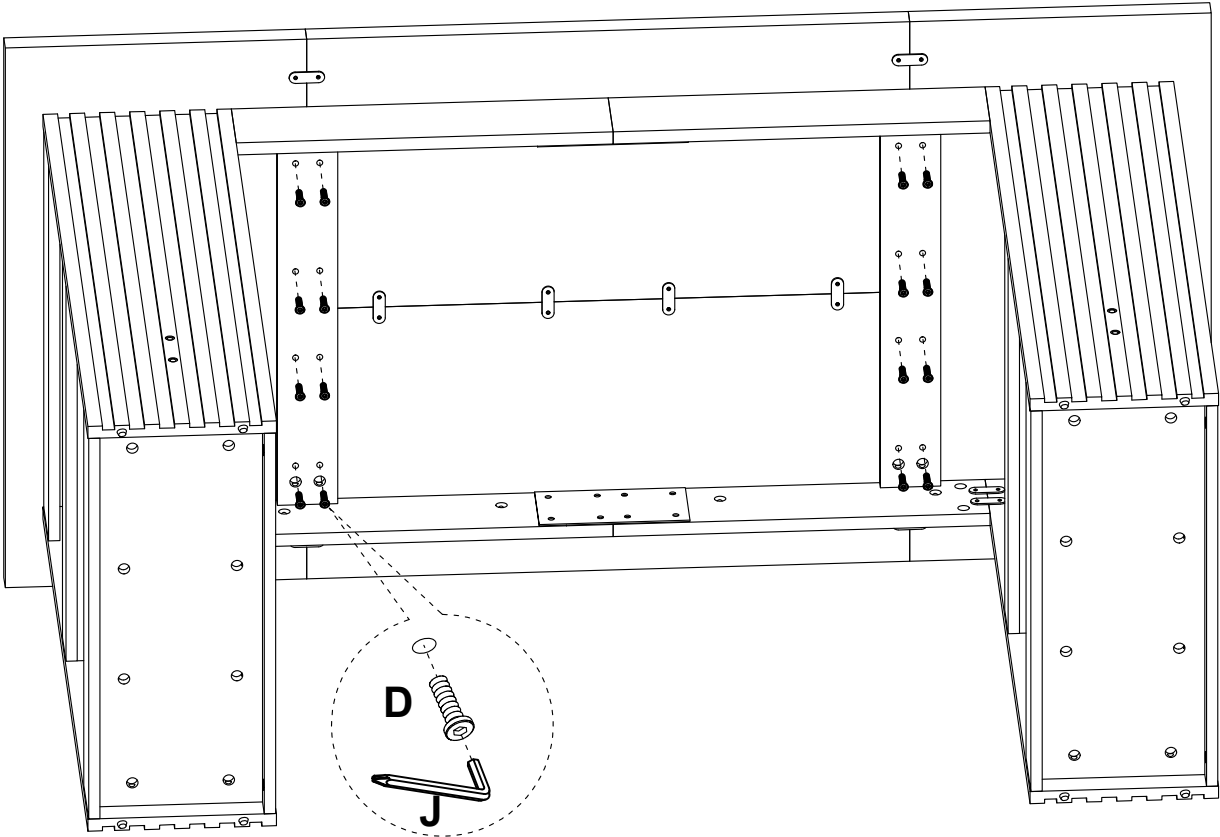

18

D	J
	
M6x25mm	M4
16 pcs	1 pc



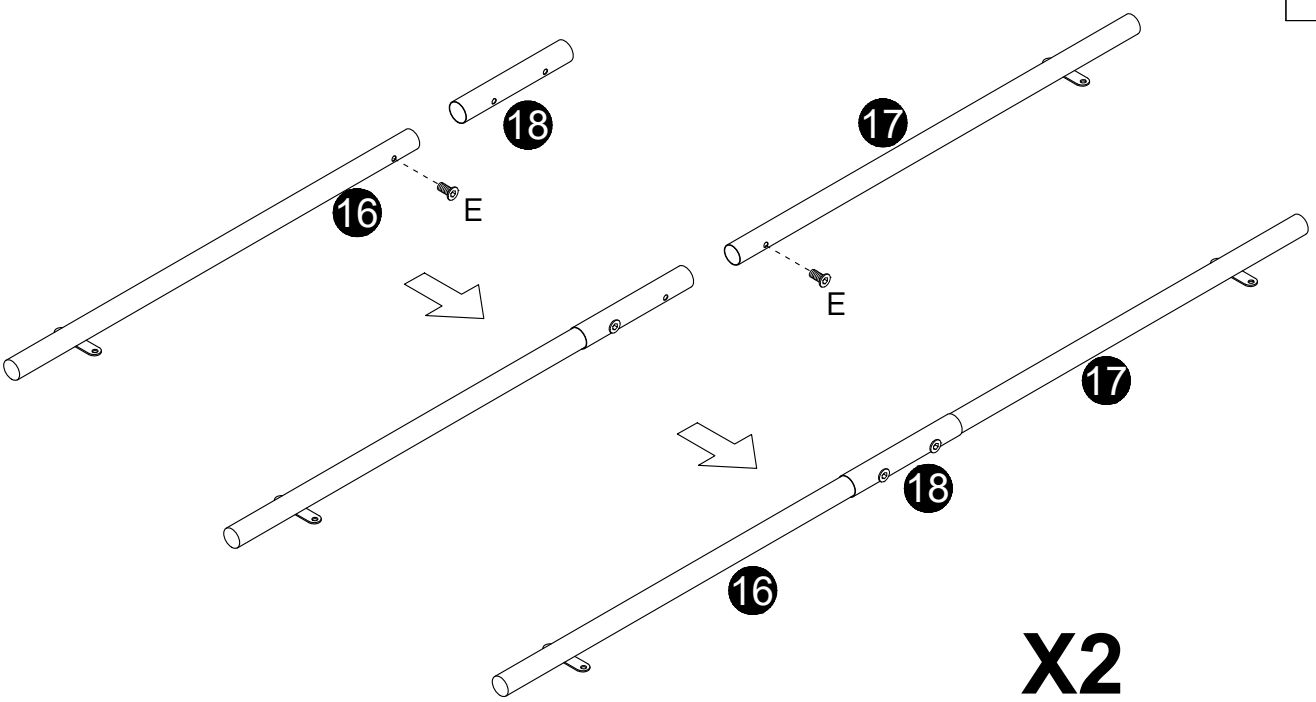

19

E

M6x12mm
4 pcs



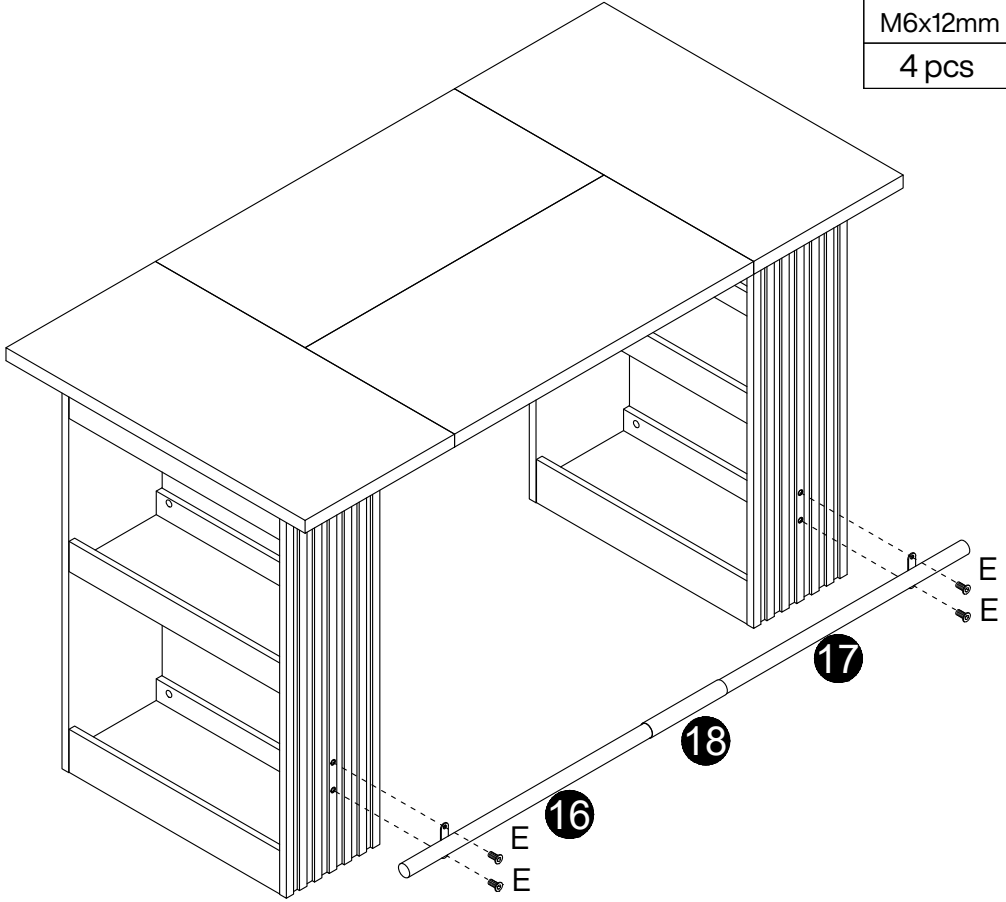

20

E	J
	
M6x12mm	M4
4 pcs	1 pc



21

E	J
	
M6x12mm	M4
4 pcs	1 pc

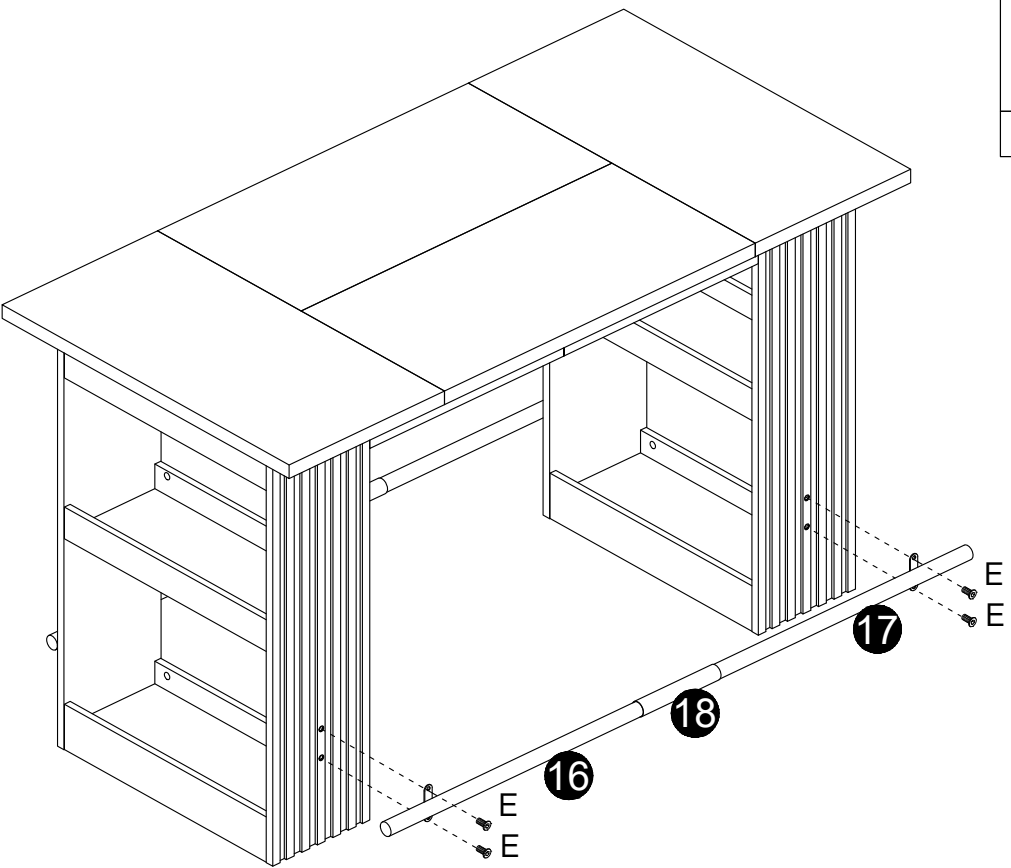

Thank you for your support!

