

ASSEMBLY INSTRUCTIONS

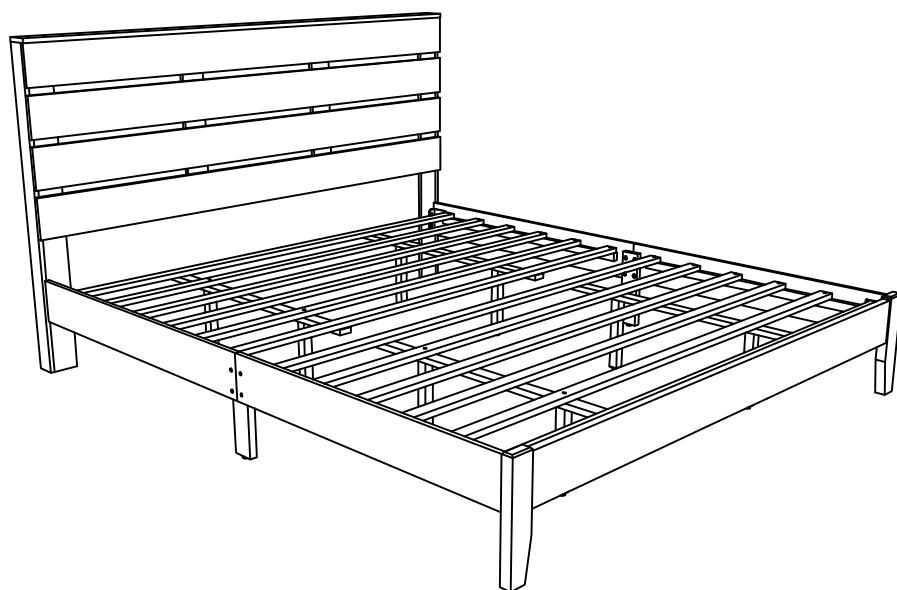

TOOLS REQUIRED



Allen Wrench

(Included)



Phillips
Screwdriver

(Not Included)

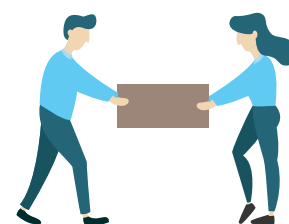

**3 - People
Recommended**

ASSEMBLY RATING



EASY —————> DIFFICULT

The Assembly Rating is a 5-point system showing the level of effort needed to assemble a specific product.



CHECK BEFORE STARTING

Are you missing anything?

Double-check all parts, hardware and accessories listed on Page 6 are accounted for.

Check out our Quick Tips!

We recommend reviewing the pre-assembly handouts. Even experts need a refresher now and then!

Should we send any replacements?

Are there any irregularities or flaws in the parts? We can send replacements!

Prep Time!

Please review the assembly instructions and all diagrams prior to assembling. Arrange parts as recommended on Page 7 and group identical hardware together to make assembling easier.

PRE ASSEMBLY INTRODUCTION

We understand building ready-to-assemble furniture can be a challenging experience for some. To help avoid confusion, we have provided some helpful tips that may speed up the process.



Teamwork

ALWAYS have at least two people to help with transporting and assembling the product to avoid potential injury and/or damage.

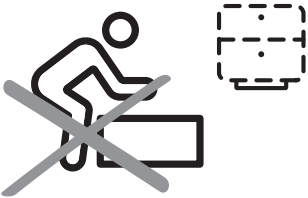

Suitable Location

Assembling near the area of the intended location is highly recommended.



Sufficient Space

Make sure you have enough space to move around during the assembly.

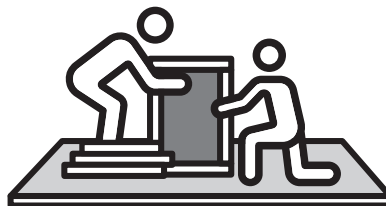

Avoid Scratches

Use cardboard, blankets or a carpeted area while assembling furniture to prevent scratches.

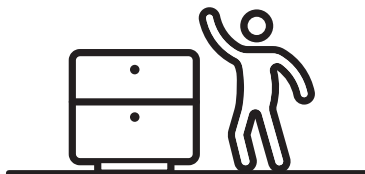

Flat Surface

Make sure the furniture rests on a flat and level surface with each leg evenly touching the floor.

ASSEMBLY AND CARE ADVICE



FAILURE TO FOLLOW THE GUIDELINES BELOW MAY RESULT IN INJURY AND/OR PROPERTY DAMAGE.



Position each part correctly and insert screws or bolts into their respective holes.



Use the appropriate hand tools or power tools for assembly. Select steps, such as tightening screws and/or bolts, may require hand tools to avoid causing damage during assembly.



Turn clockwise to tighten and only tighten when step is completed or when instructed to do so.



Save the instructions and store any supplied tools for later maintenance.



After two weeks, check and tighten any loose hardware and repeat again every six months thereafter.

IT IS THE USER'S RESPONSIBILITY TO MAINTAIN THE FURNITURE. THE HARDWARE MAY LOOSEN OVER TIME AND MAY CAUSE THE FURNITURE TO BE WOBBLY AND UNABLE TO SUPPORT ITS INTENDED WEIGHT CAPACITY. THIS MAY LEAD TO COLLAPSE AND MAY CAUSE SERIOUS INJURY.







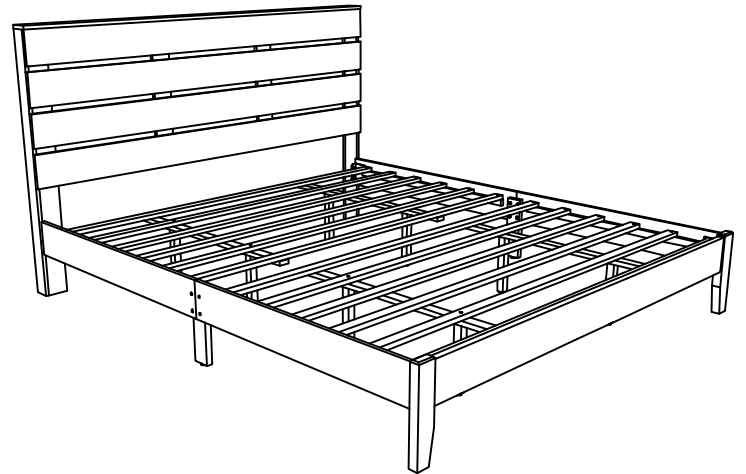





CAL.KING BED













- Please keep instructions for future reference.
- Check the quantity and irregularity of parts and hardware before you start.



PARTS

#1 1pc  Top Front Headboard	#2 3pcs  Front Headboard Panel	#3 1pc  Footboard Panel	#4 2pcs  Headboard Leg(L&R)	#5 2pcs  Headboard Center Panel	#6 2pcs  Side Rail Left
#7 2pcs  Side Rail Right	#8 1pc  Footboard Leg Left	#9 1pc  Footboard Leg Right	#10 2pcs  Side Rail Leg	#11 12pcs  Bed Slat - 1845x45x18mm	#12 8pcs  Bed Slat Support - 255x30x30mm
#13 4pcs  Bed Center Slat - 940x45x18mm					

HARDWARE

#A 8pcs  Bolt 1/4" x 1-3/8"	#B 10pcs  Bolt 1/4" x 2"	#C x 10pcs  Lock washer	#D x 8pcs  Flat washer	#E 24pcs  CSK M4 x 32mm	
#F 26pcs  Pan Head Screw M4 x 25mm	#G 4pcs  Wood Dowel M8 x 30mm	#H 28pcs  Wood Dowel M8 x 20mm	#I 1pc  Allen Key with Ball M4 x 110mm	#J 1pc  Allen Key M5 x 65mm	#K 2pcs  Bend-Washer 15mm x 25mm

ASSEMBLY INSTRUCTIONS

1

Part #1 x1pc

Part #4 x2pcs

Hardware #F x6pcs

Align Headboard Leg(#4) to the Top front Headboard(#1), then secure by using pan head screw(#F)

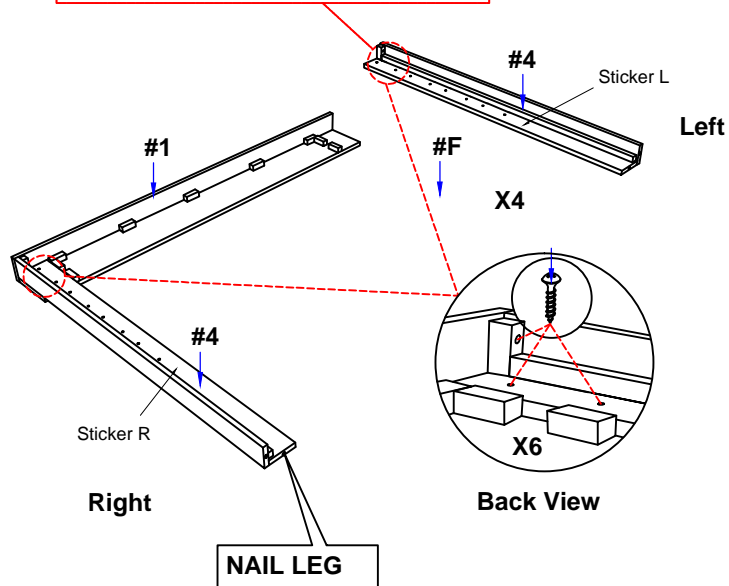

2

Hardware #H x12pcs

Turn-over the fixed part (#1) & (#4) then insert the dowel (#H) into pre drilled hole provided on Headboard Leg (L&R)(#4) as shown.

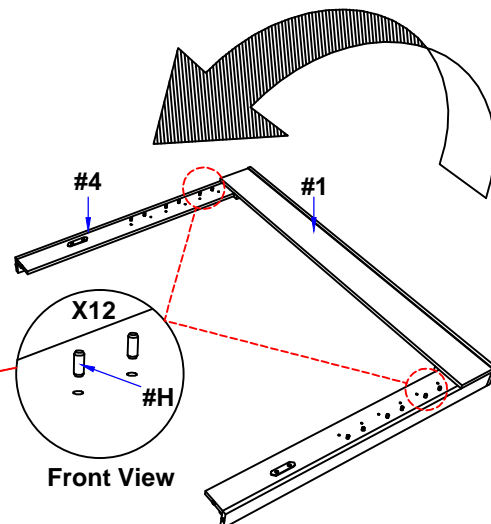

ASSEMBLY INSTRUCTIONS

3

Part #2 x3pcs

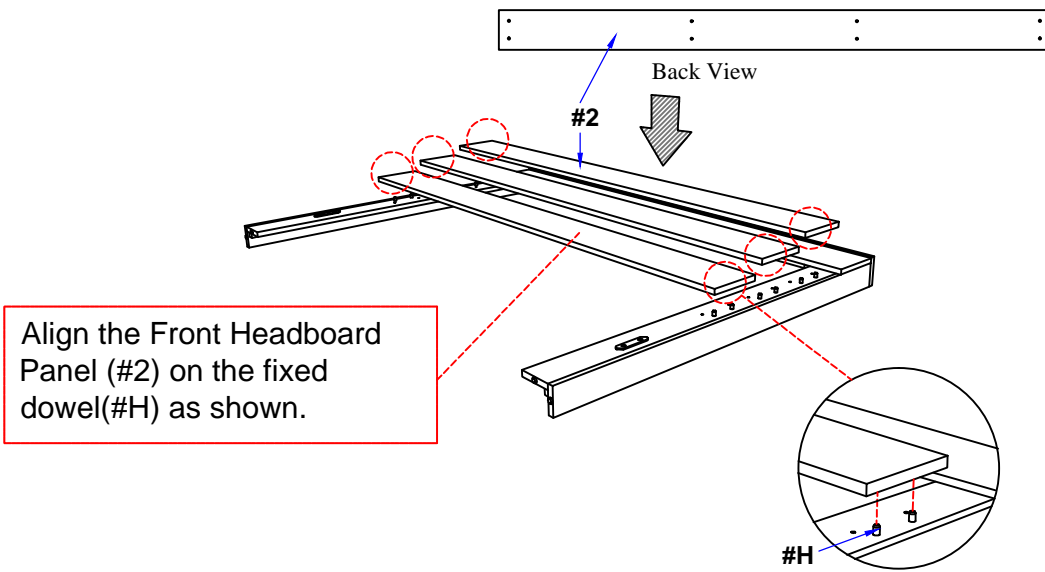

4

Part #5 x2pcs

Hardware #F x20pcs

Hardware #H x16pcs

Secure Headboard Leg (L&R)(#4) and Front Headboard Panel (#2) with Pan Head Screw(#F) by tighten with Screw Driver (NOT PROVIDED) as shown..

Lift Headbord with Upside down position as shown

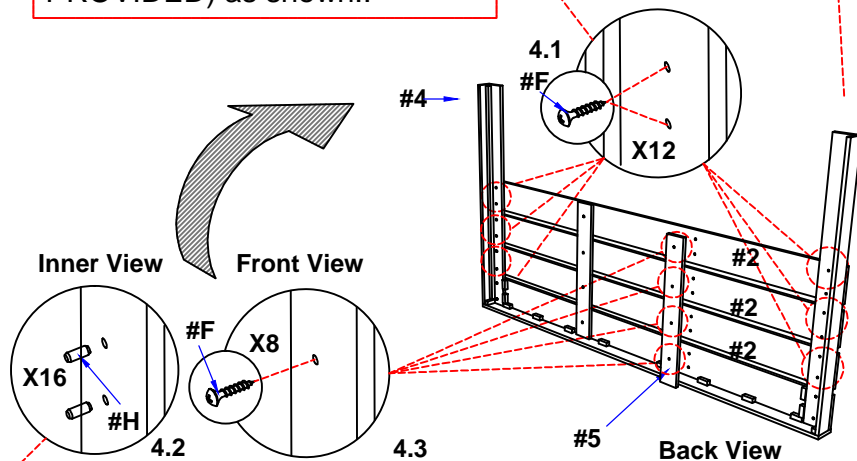

Align The Headboard Center Panel (#5) by inserting The Dowel(#H) into the predrilled hole at back of Headboard Center Panel and secure with Pan Head Screw(#F) and tighten it with Screw Driver (NOT PROVIDED) a shown.

ASSEMBLY INSTRUCTIONS

5

- Part #3 x1pc
- Part #8 x1pc
- Part #9 x1pc
- Hardware #B x2pcs
- Hardware #C x2pcs
- Hardware #G x4pcs
- Hardware #K x2pcs

Insert Dowel (#G) to the Footboard Panel (#3) and attach Footboard Leg(L&R) (#8) & (#9) accordingly secure with JCBC (#B), Spring washer (#C) and Bend-Washer (K) . Tighten with Allen Key (#I) as shown.

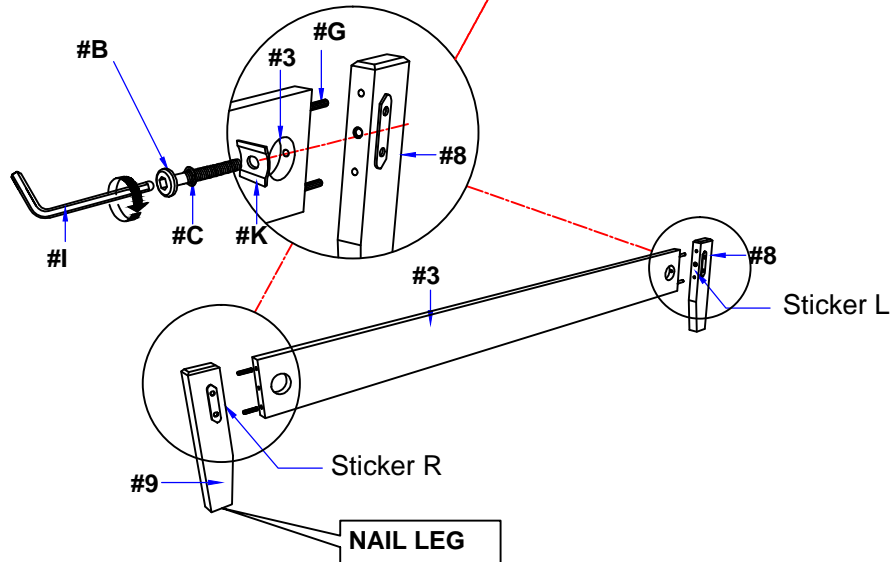

6

- Part #6 x2pcs
- Part #7 x2pcs
- Part #10 x2pcs
- Hardware #A x8pcs
- Hardware #C x8pcs
- Hardware #D x8pcs

Align the side rail (#6) & (#7) to the Side Rail Leg (#10). Secure with JCBC (#A), Spring washer (#C) and Flat washer (#D). Tighten with Allen Key (#I). Repeat the same step for other Side Rail Assembly.

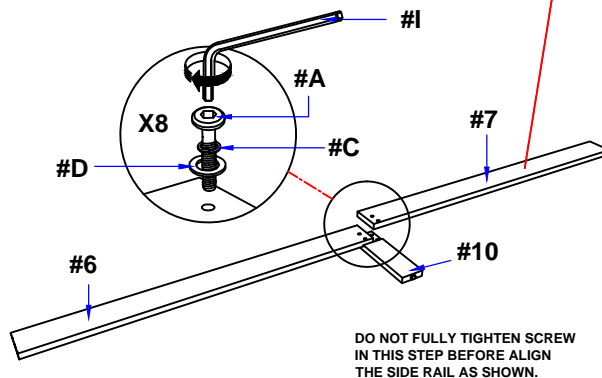

ASSEMBLY INSTRUCTIONS

7

Align the Side Rail (#6) and (#7) to Headboard & Footboard then secure by tightening bolts.

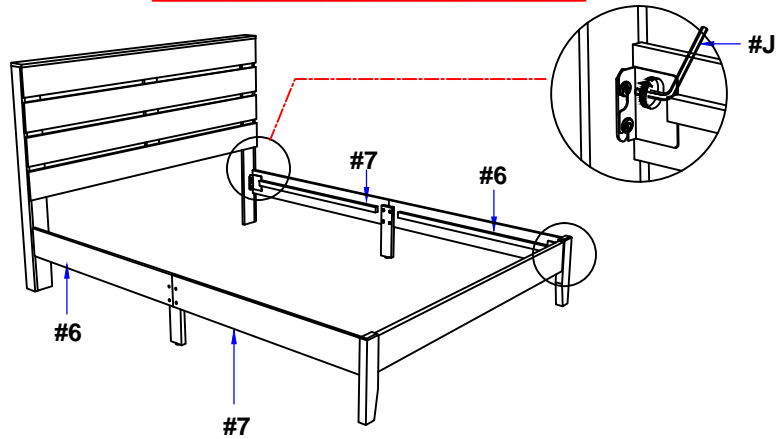

8

- Part #11 x12pcs
- Part #12 x8pcs
- Part #13 x4pcs
- Hardware #B x8pcs
- Hardware #E x24pcs

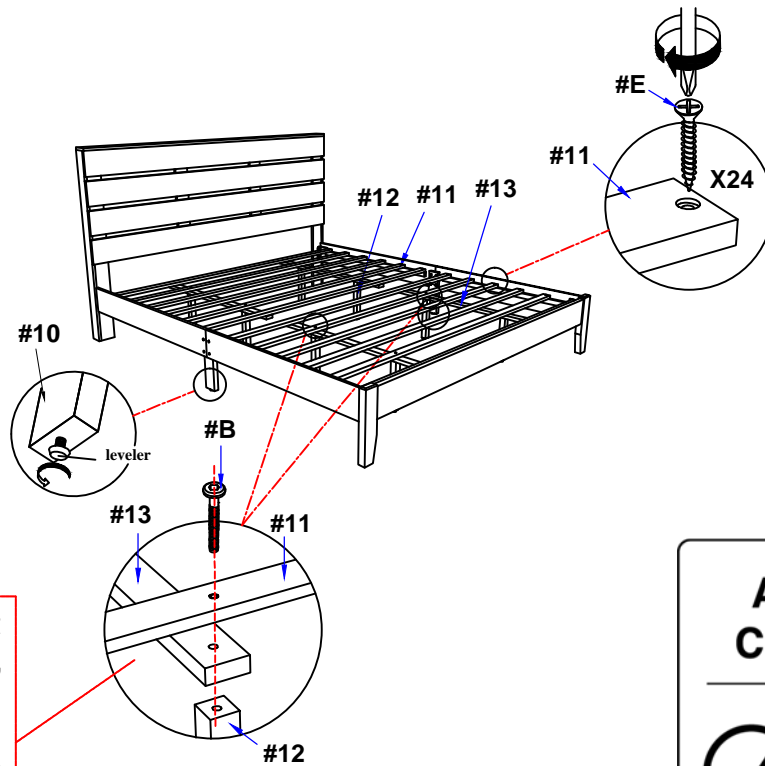

Align the Bed Slat Support Leg (#12), to Bed Slat (#11) and Center slat (#13) secure with JCB (#B) as shown. Fix the bed slat (#11) to side rail (#6)&(#7) and tighten with Csk Screw (#E) as per diagram shown. Repeat step 8 for other set of slats assembly.

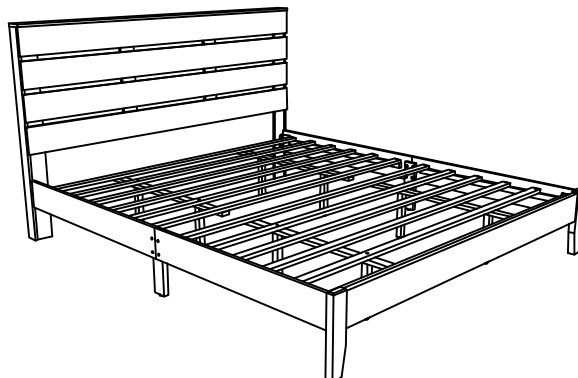

ASSEMBLY COMPLETED



Please ensure the furniture rests on an even and flat surface. If the product wobbles or feels loose, double-check all bolts and/or screws are properly tightened and secured.



Keep this handy!

Please retain this instruction manual and any order-related information for future reference.



Lift, don't drag!

To avoid damage to product please always LIFT the product when transporting or adjusting the placement.