



Project Name:	
Location:	
Item:	Qty:
Model:	

# MIM50-O

## Indoor/Outdoor Ice Maker



Model MIM50-O



FEATURE LIST	
Model:	MIM50-O
Description:	Maxx Ice 50lb Outdoor Ice Maker
Voltage:	120V/60Hz/1Ph, 220V/50Hz/1Ph
Amps:	4.8
Ice Type:	Slab Cube
Ice Cube Size:	1.3" W x 1.125" D x 1" H
Water Consumption:	20 gal / 100 lb ice
Unit Weight:	83 lb / 37 kg
Unit Dimensions:	15" W x 23" D x 34" H 381mm W x 584.2mm D x 863.6mm H
Shipping Weight:	93 lb / 42 kg
Shipping Dimensions:	17" W x 26 3/4" D x 38" H 432mm W x 678mm D x 965mm H

The compact Indoor/Outdoor MIM50-O produces up to 50 pounds of ice per day and includes a self-contained 25 pound storage bin. The unit produces crystal clear ice cubes and features a stainless steel finish. Suitable for freestanding or built in applications, this unit will run on standard household electrical current and is UL approved for commercial use.

Maxx Ice's continuing commitment to quality products may mean a change in specification or pricing without notice.

### MAXX ICE

3355 Enterprise Avenue Fort Lauderdale, FL 33331  
 Tel: 954.202.7336 www.thelegacycompanies.com



Project Name:	
Location:	
Item:	Qty:
Model:	

# MIM50-O

Outdoor Ice Maker

## PLAN VIEW

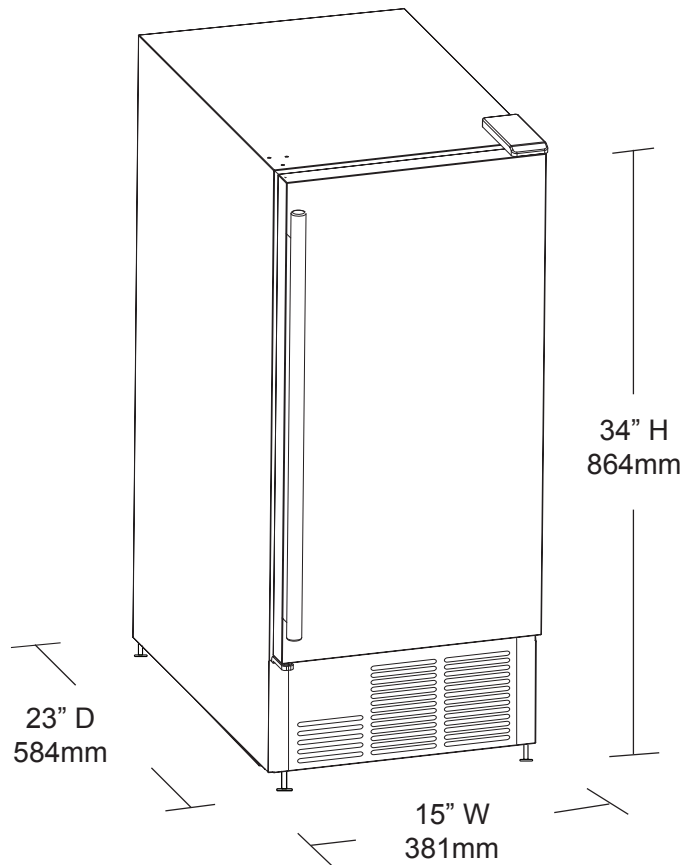

- Based on 70°F Air/50°F Water 21°C Air/10°C Water
  - Produces Up to 50lb (23kg) every 24 hours
- Produces clear ice cubes
- 25 lb storage bin with automatic overflow prevention
- Condenser: Air Cooled
- Indoor/Outdoor Use
- Stainless Steel Reversible Door
  - Unit ships with hinge on right.
  - Easily changed to left during installation.
- Sturdy, plastic legs (adjustable)
- Household or Commercial Use
- Freestanding or Built-In Applications

\* Gravity drain required. Water Filter recommended.

### MAXX ICE

3355 Enterprise Avenue Fort Lauderdale, FL 33331  
Tel: 954.202.7336 [www.thelegacycompanies.com](http://www.thelegacycompanies.com)