

# ASSEMBLY INSTRUCTIONS

## TWIN BED

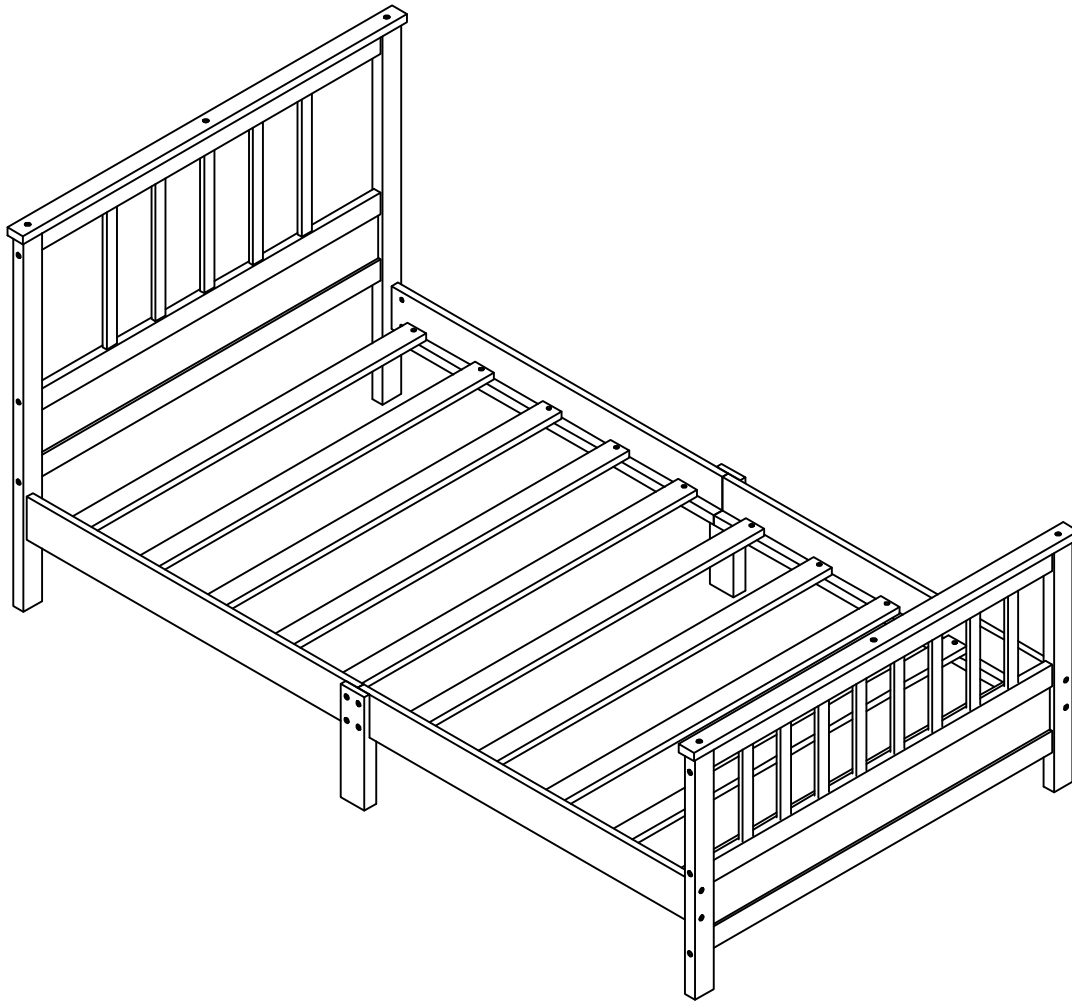

STEP 5:

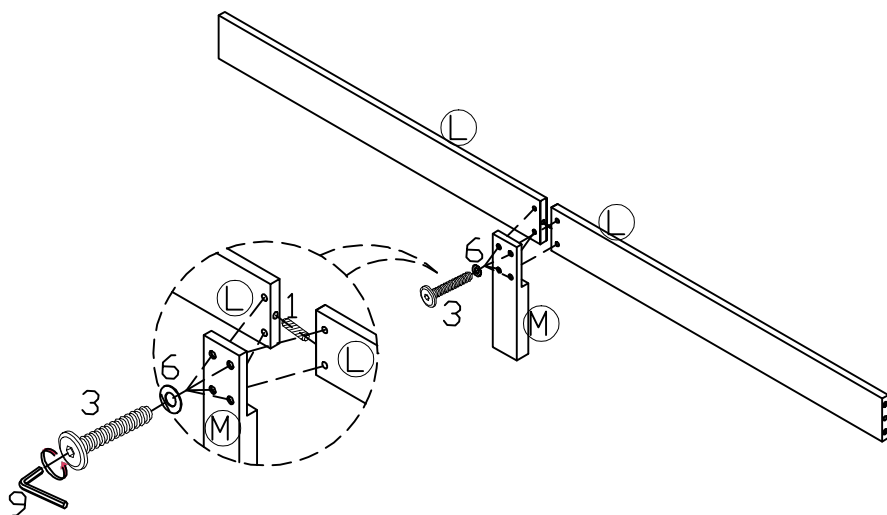



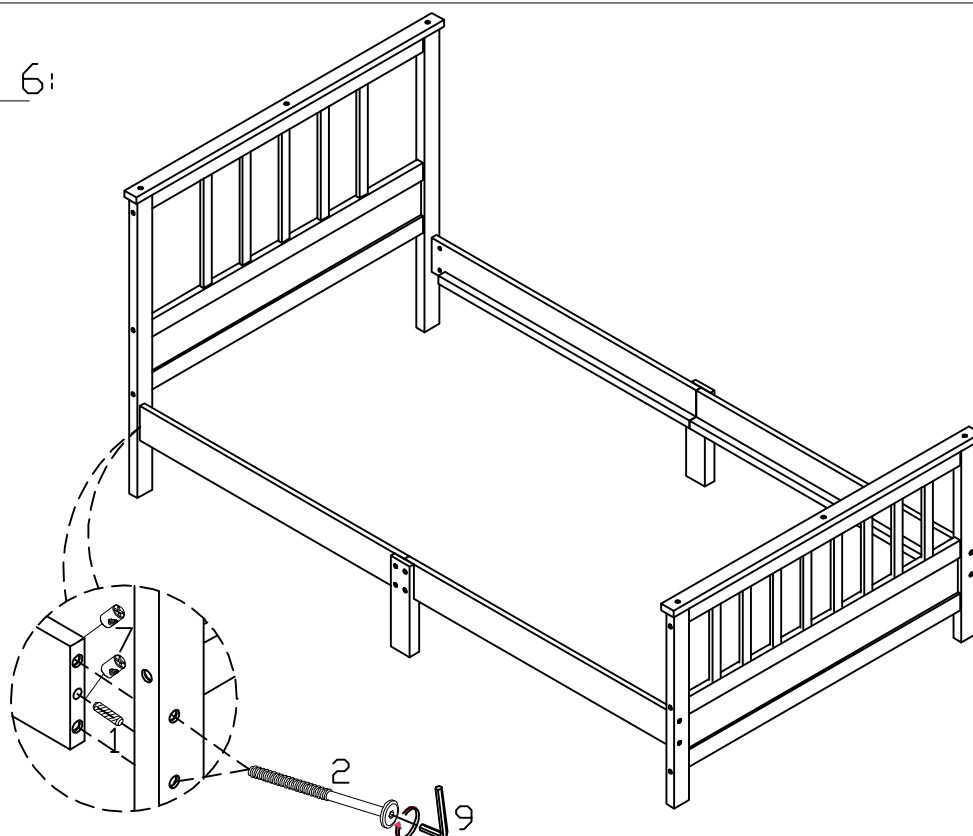



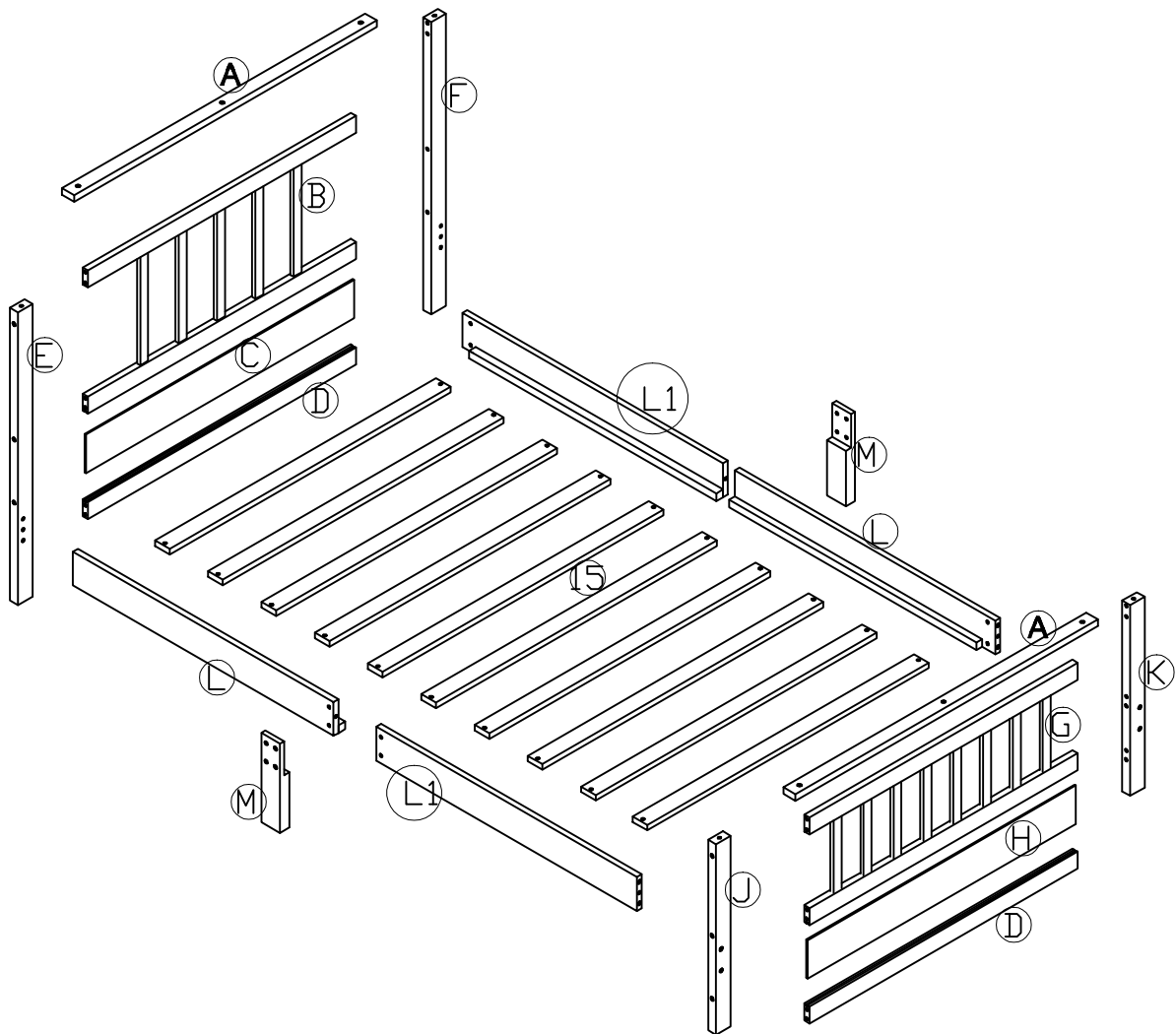

STEP 6:

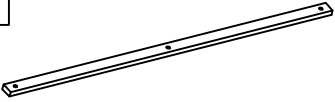
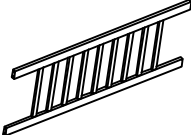
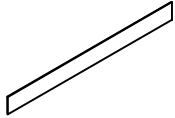

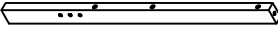

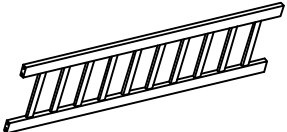

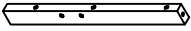
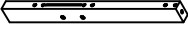
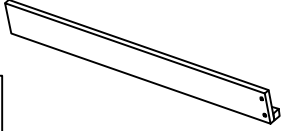

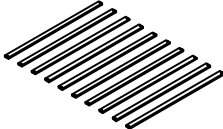
## Detail View

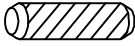
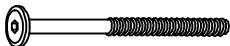

**Part List**

<p><b>A</b></p> 	<p><b>B</b></p> 	<p><b>C</b></p> 
<p>Horizontal bar - 2pcs</p>	<p>Headboard frame - 1pc</p>	<p>Headboard panel - 1pc</p>
<p><b>D</b></p> 	<p><b>E</b></p> 	<p><b>F</b></p> 
<p>Headboard bottom rail-2pc</p>	<p>Headboard Leg(Left) - 1pc</p>	<p>Headboard Leg(Right) - 1pc</p>
<p><b>G</b></p> 	<p><b>H</b></p> 	
<p>Footboard Frame - 1pc</p>	<p>Footboard panel - 1pc</p>	
<p><b>J</b></p> 	<p><b>K</b></p> 	<p><b>LL1</b></p> 
<p>Footboard leg (Left) - 1pc</p>	<p>Footboard leg (Right) - 1pc</p>	<p>Side rail -4pcs</p>
<p><b>M</b></p> 	<p><b>15</b></p> 	
<p>Center rail Leg -2pcs</p>	<p>Slats -10pcs</p>	

**Hardware List**

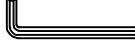
<p><b>1</b></p>  <p>∅10 × 30mm</p>	<p><b>2</b></p>  <p>(∅15)1/4" × 85mm</p>	<p><b>3</b></p>  <p>(∅15)1/4" × 25mm</p>
<p>Wood dowel (18pcs)</p>	<p>Hex-Head bolts (8pcs)</p>	<p>Hex-Head bolts (8pcs)</p>
<p><b>4</b></p>  <p>∅1/4" × 50mm</p>	<p><b>5</b></p>  <p>∅1/4" × 110mm</p>	<p><b>6</b></p>  <p>∅1/4"mm</p>
<p><b>Hex-Head bolts (6pcs)</b></p>	<p><b>Hex-Head bolts (2pcs)</b></p>	<p><b>Flats washer (8pcs)</b></p>
<p><b>7</b></p>  <p><b>1/4"×15 (9.5mm)</b></p>	<p><b>8</b></p>  <p><b>∅4*30mm</b></p>	<p><b>9</b></p>  <p><b>(1/4")4.5*58mm</b></p>
<p>Horizontal-Hole bolts(8pcs)</p>	<p>Wood screws (20pcs)</p>	<p><b>Allen key (1pcs)</b></p>

**ASSEMBLY TOOLS REQUIRED ( NOT INCLUDED )**

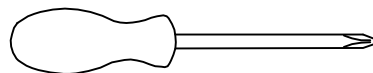

**PLEASE BE CAREFUL DO NOT DAMAGE THE HOLE POSITION WHEN YOU USE POWER TOOLS !**

**STEP 1:**

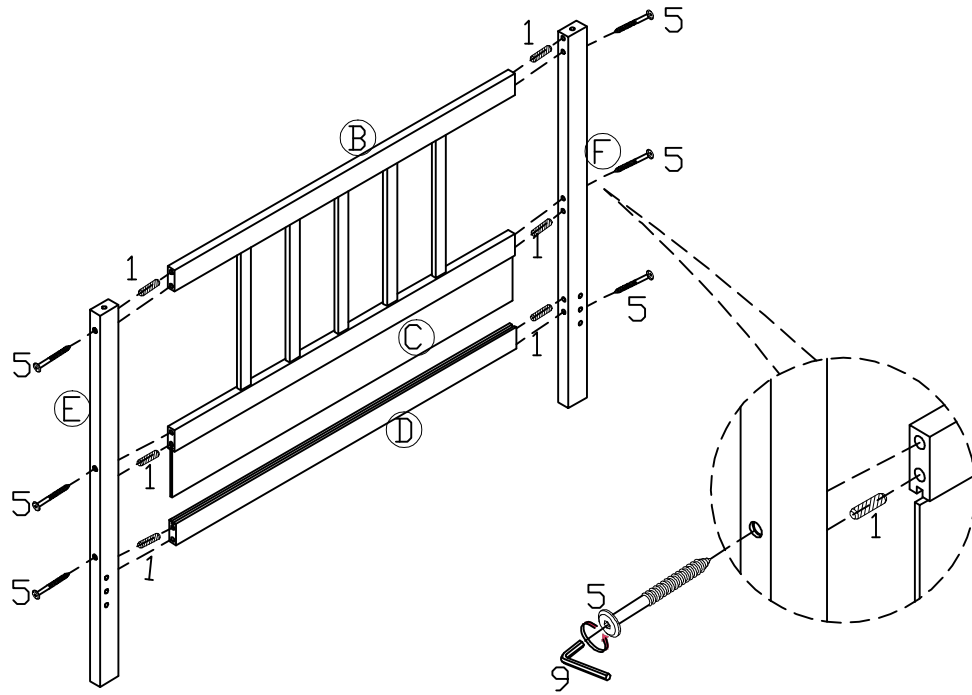

**STEP 2:**

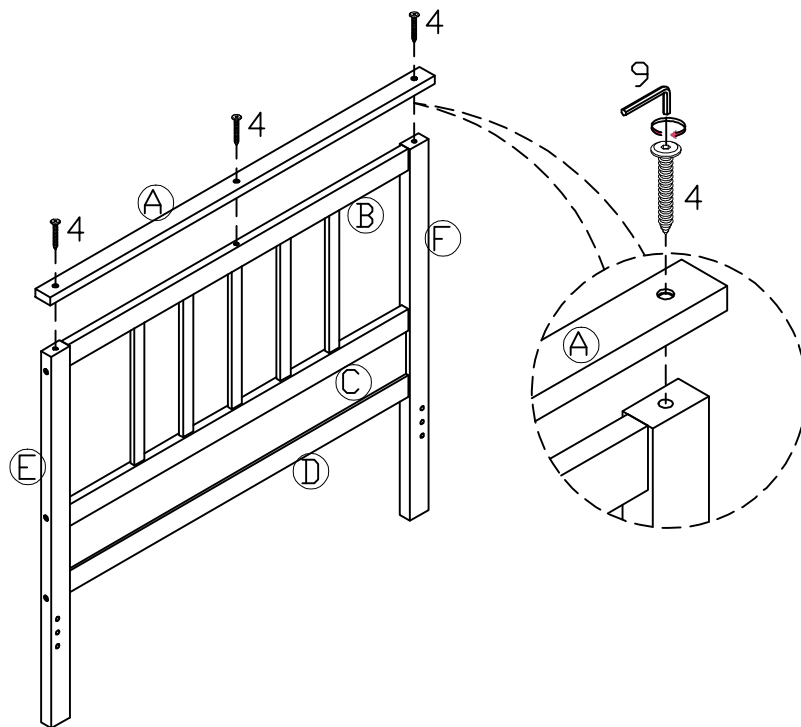

STEP 3:

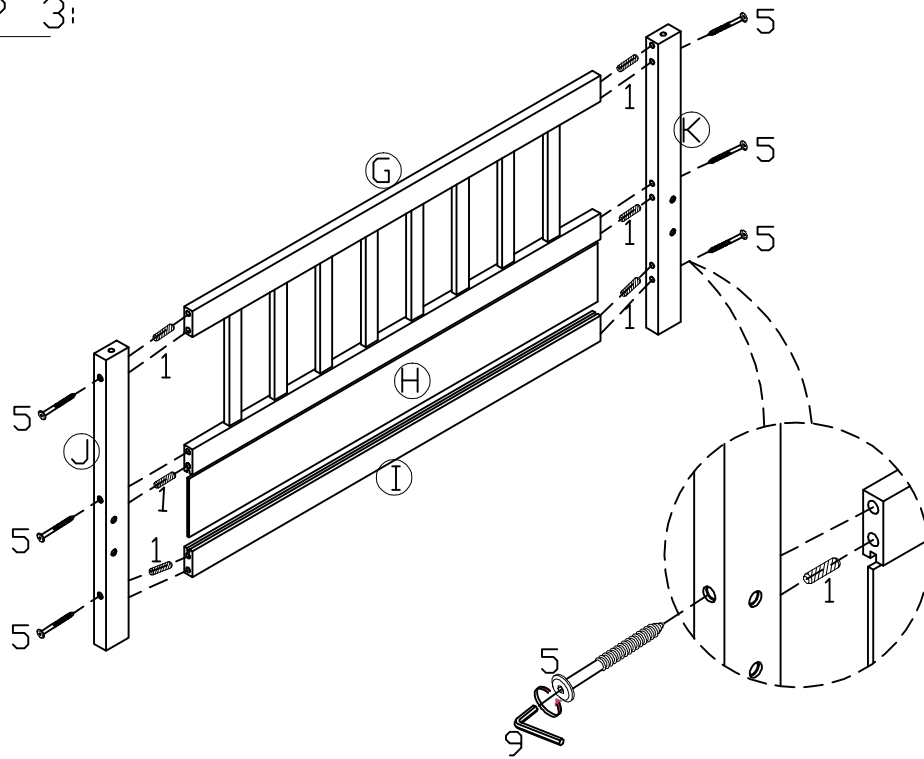

STEP 4:

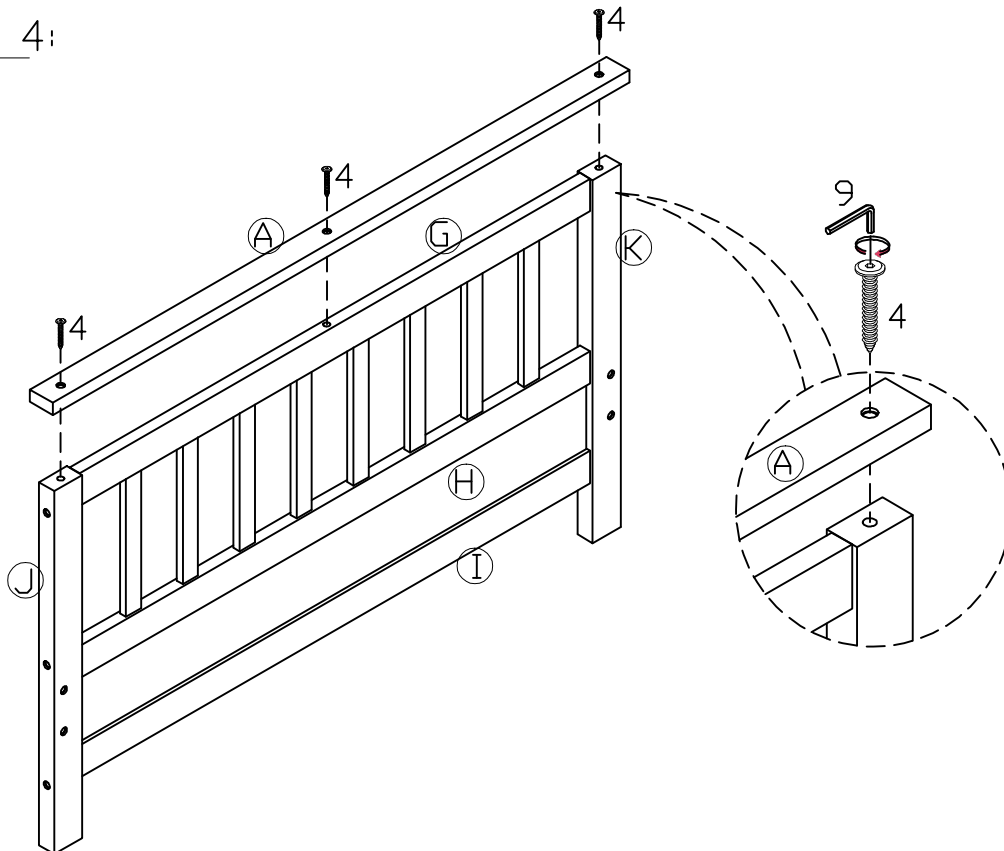

STEP 5:

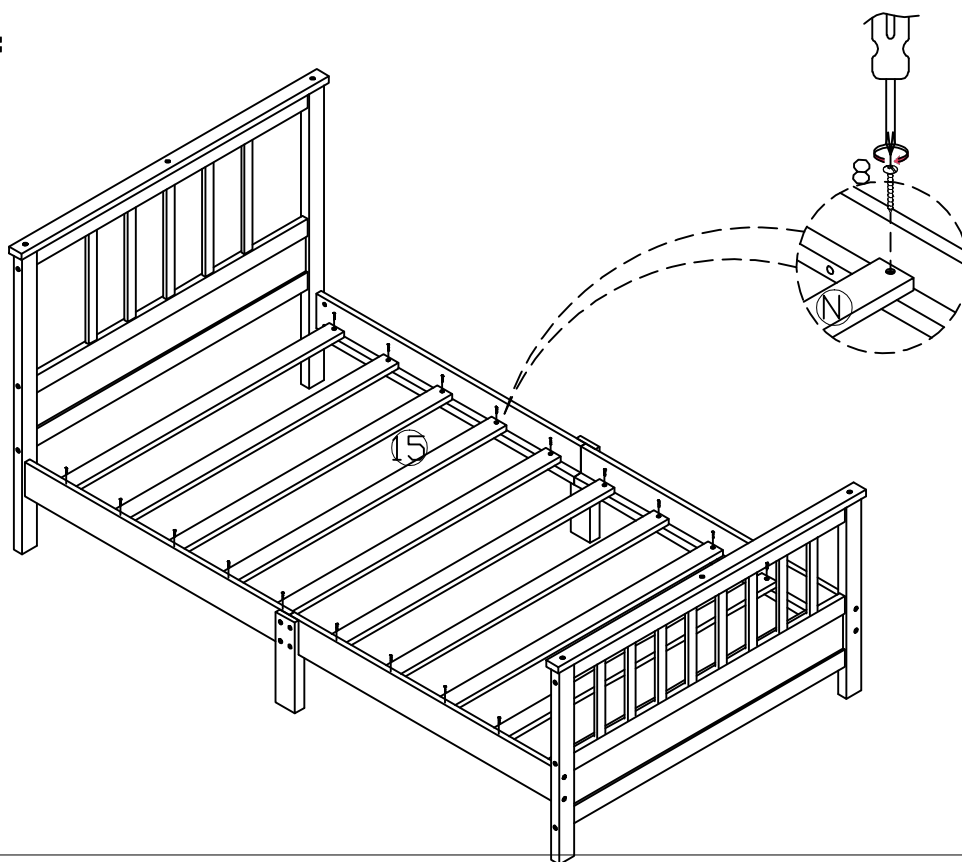

STEP 6:

