

PLATFORM BED

TWIN/FULL/QUEEN/E-KING SIZE

ASSEMBLY INSTRUCTIONS

PARTS AND FITTING PACKAGING DETAIL

BOX #1

- A. HEADBOARD 1 PC
- B. FOOTBOARD 1 PC

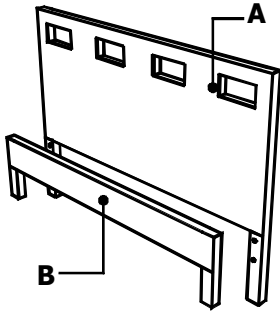

BOX #2

- C. SIDERAILS 2 PCS
- D. CENTER SLATS 1 PC
- E. CENTER LEG 4 PCS
- HARDWARE BOX

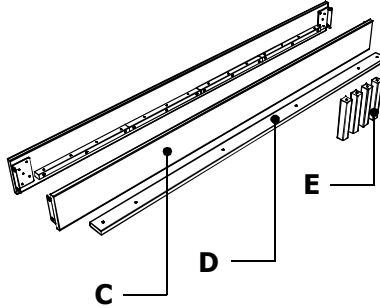

BOX #3

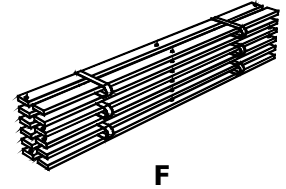

- F. BED SLATS 12 PCS

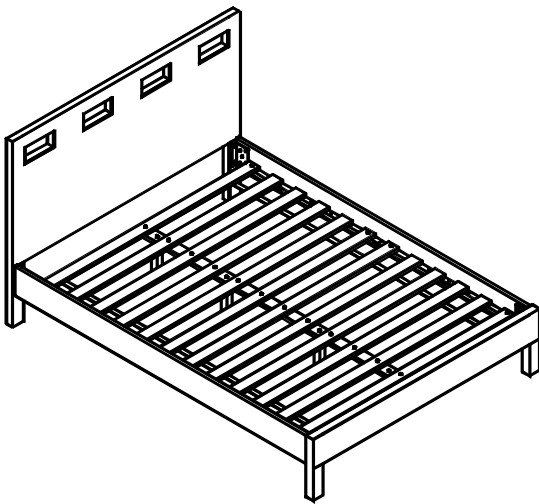

PLATFORM BED ASSEMBLED

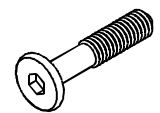
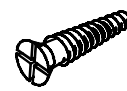
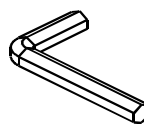

HARDWARE PACKED IN BOX #2

1	PHILLIPS HEAD BOLT 20MM	8 PCS	2	WASHERS 8MM	8 PCS	3	ALLEN BOLT 40MM	10 PCS
								
4	WOOD SCREW Ø8X30MM	8 PCS	5	ALLEN KEY	1 PC	YOUR BOX MAY CONTAIN EXTRA HARDWARE		
								

TOOL REQUIRED :

PHILLIPS HEAD SCREW DRIVER (NOT PROVIDED)

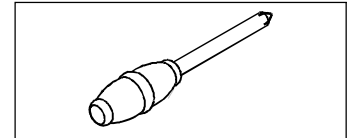

STEP 1 :

FIX ONE OF THE SIDERAILS (C) TO THE HEADBOARD (A) USING PHILLIPS HEAD BOLTS (1) AND WASHERS (2).

DO NOT TIGHTEN BOLTS COMPLETELY UNTIL ASSEMBLY IS COMPLETED.

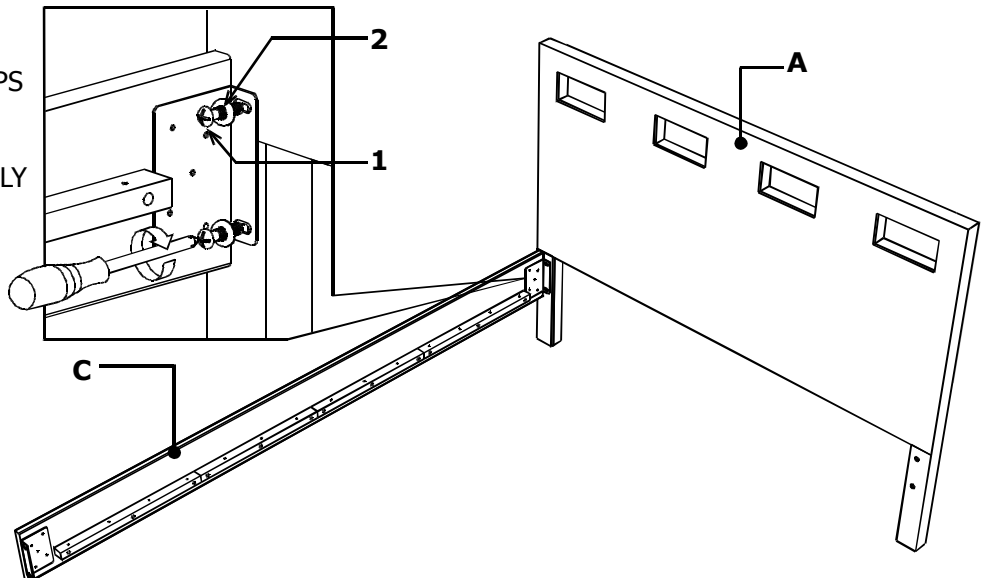

STEP 2 :

FIX THE OTHER END OF THE SIDERAIL (C) TO THE FOOTBOARD (B) USING PHILLIPS HEAD BOLTS (1) AND WASHER (2).

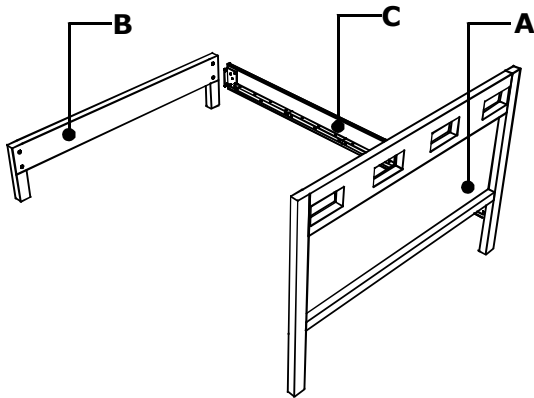

STEP 3 :

FIX THE OTHER SIDERAIL (C) TO THE HEADBOARD (A) AND FOOTBOARD (B).

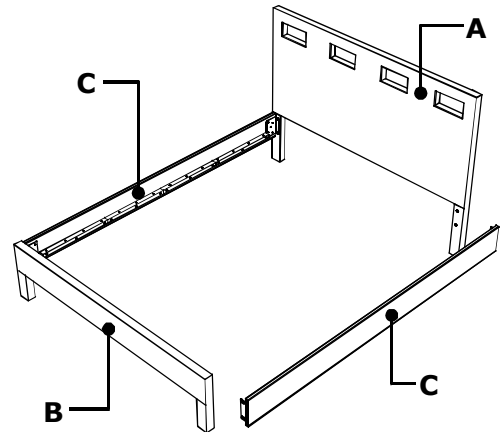

STEP 4 :

ARRANGE CENTER SLAT (D) SO THAT T-NUTS ARE FACING THE FLOOR. SLIDE ALLEN BOLTS (3) FROM TOP OF CENTER SLAT (D) INTO THE 2ND, 5TH, 6TH, AND 9TH PREDRILLED HOLES. FIX CENTER LEGS (E) TO CENTER SLAT (D) USING ALLEN BOLTS (3) AND ALLEN KEY (5).

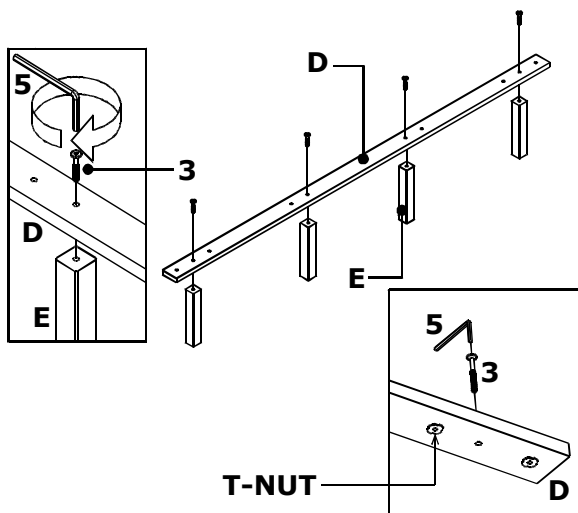

STEP 5 :

SPREAD BED SLATS (F) ON BED FRAME. FIX 1ST, 6TH, 7TH, AND 12TH BED SLATS TO BED FRAME USING WOOD SCREWS (4). USE PILOT HOLES ON SIDERAILS (C) AS REFERENCE FOR CORRECT PLACEMENT.

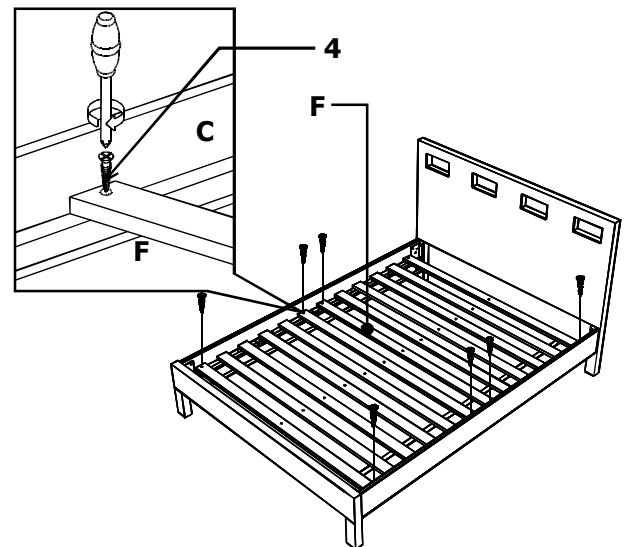

STEP 6 :

SLIDE CENTER SLAT (D) UNDER BED SLATS (F). SLIDE ALLEN BOLTS (3) FROM TOP OF BED SLATS (F) THROUGH PRE-DRILLED HOLES ON 1ST, 2ND, 5TH, 8TH, 11TH AND 12TH BED SLATS. TIGHTEN ALLEN BOLTS (3) WITH ALLEN KEY (5) TO SECURE BED SLATS (F) TO CENTER SLAT (D).

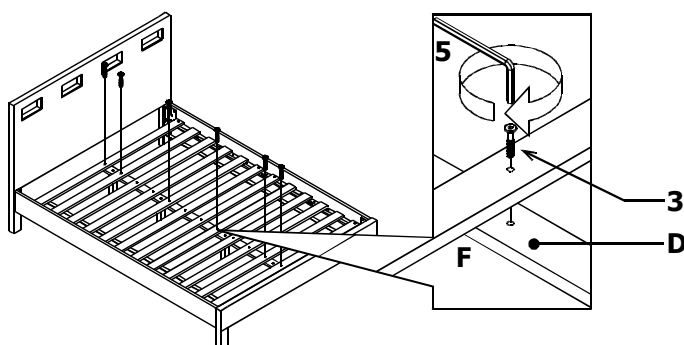

INSTRUCTIONS FOR ADJUSTING LEVELERS:

POSITION THE BED IN YOUR ROOM LOCATE LEVELERS UNDER EACH CENTER LEG (E).

TURN COUNTER-CLOCKWISE TO EXTEND, CLOCKWISE TO CONTRACT.

ADJUST LEVELERS UNTIL EACH LEG IS APPLYING EQUAL UPWARD PRESSURE ON THE CENTER SLAT.

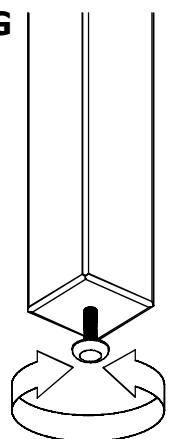

MAINTENANCE INSTRUCTIONS:

- REMOVE BOX SPRING AND MATTRESS BEFORE MOVING YOUR BED.
- LIFT YOUR BED WHEN MOVING IT. DRAGGING CAN DAMAGE CENTER SUPPORT.
- READJUST LEVELERS AFTER MOVING YOUR BED.