

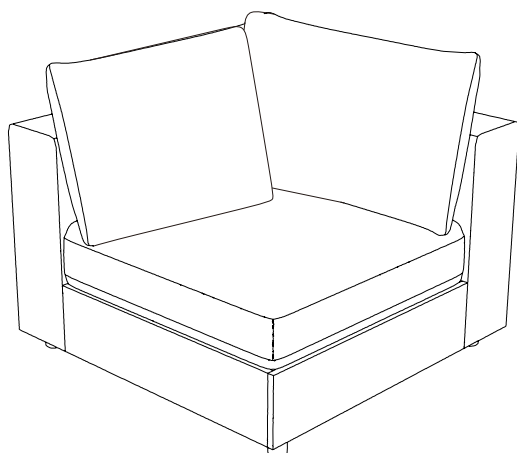

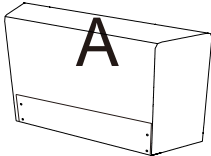

ASSEMBLY INSTRUCTION

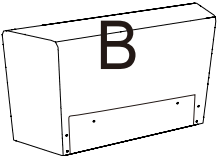

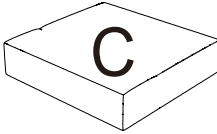

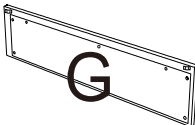
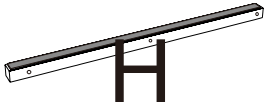
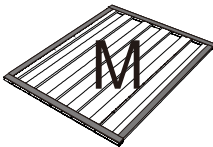

ITEM NO.:D88061.D88062.D88063.D88064.D88065.D88066-C

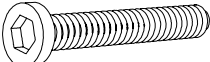

PARTS LIST

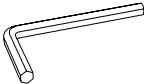
 Backrest x1	 Backrest x1	 Seat cushion x1	 Back cushion x1
 Back cushion x1	 Base Frame Side Panel x1	 Base Frame Front Panel x1	 Support Bar x2
 Slats x1			

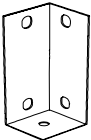
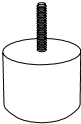
HARDWARE LIST

 1/4*20mm x16	 1/4*50mm x4	 19mm x4	 30mm*100mm x1
 x3	 x1	 x5	 x2

BEFORE ASSEMBLY

Open up Velcro of Non-Woven Fabric cover on the bottom to remove hardware, legs and parts.

1. Please open the black woven fabric with Velcro closure on the bottom of the frame then cut off the black straps before removing the parts for assembly.

2. After removing the cushion from the compress bag, please allow air to flow through the cushion for few days. You can try to fluff cushion by push in and push out on all four sides of the cushion. Hitting the top/front of the cushion with your hand to fluff them after installation.

3. Please allow at least 24 hours for the cushions to recover to its natural state after removing from the package.

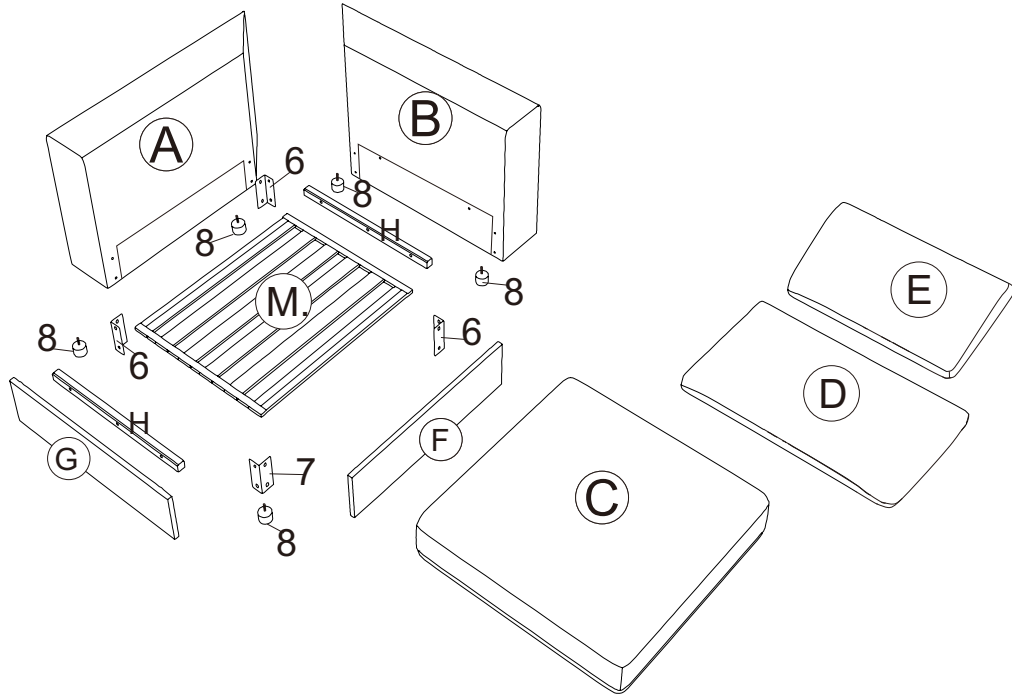
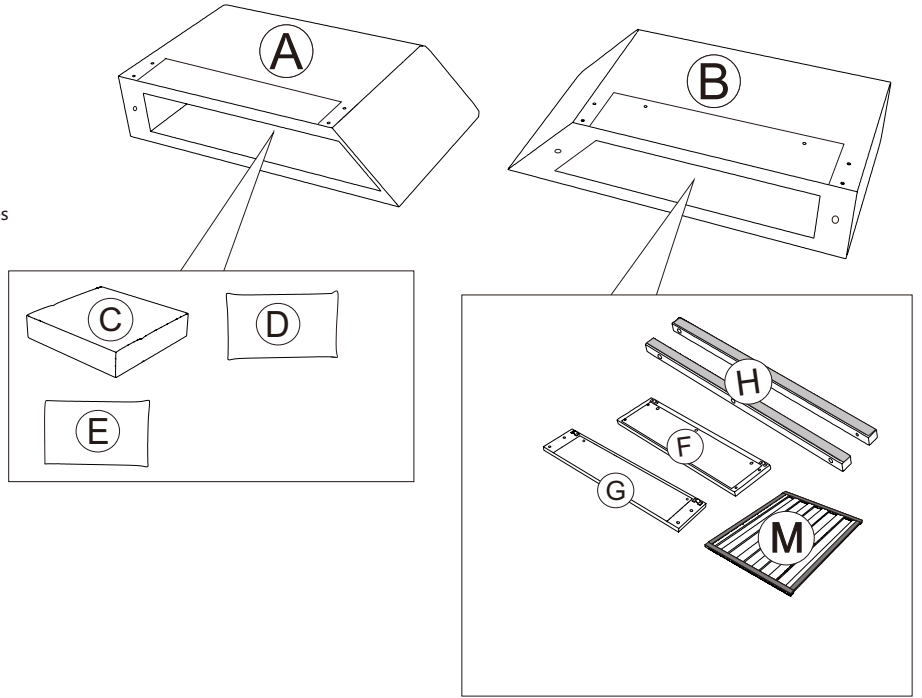
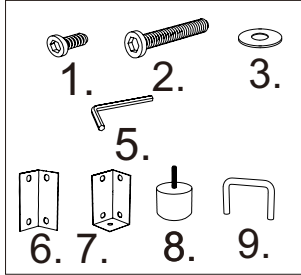

SOFA ASSEMBLY INSTRUCTION

Step1

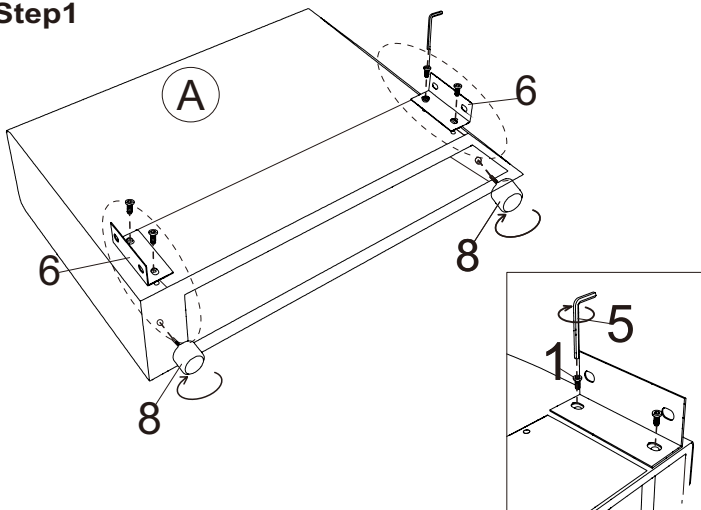

Step2

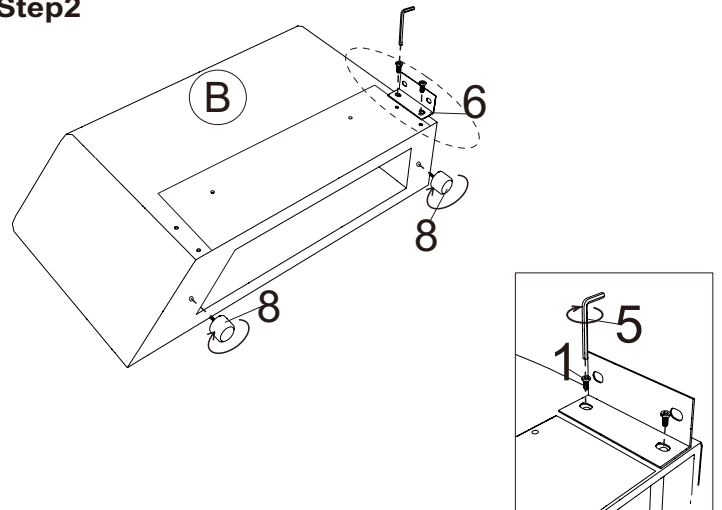

Step3

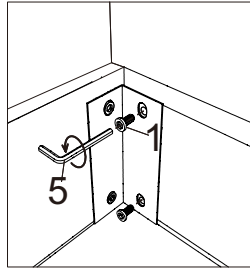
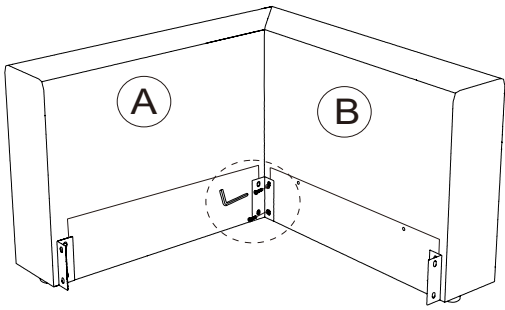

Step4

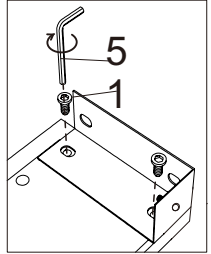
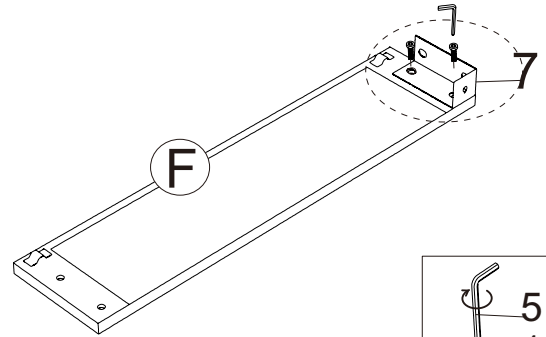

Step5

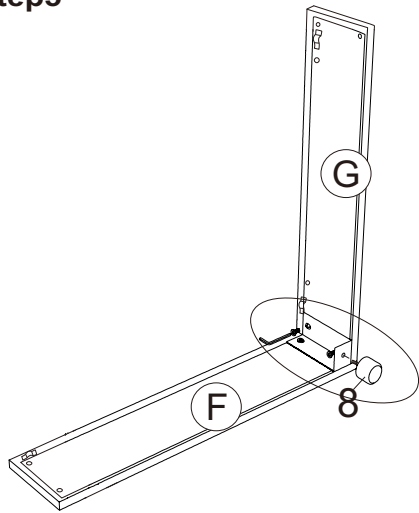

Make sure to align Part#G,F, and 7 at the same level. If there is any issue, use the oval screw holes to adjust.

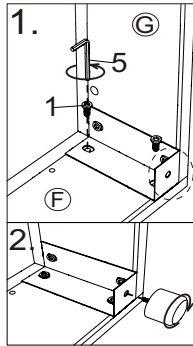

Step6

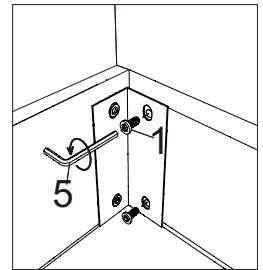
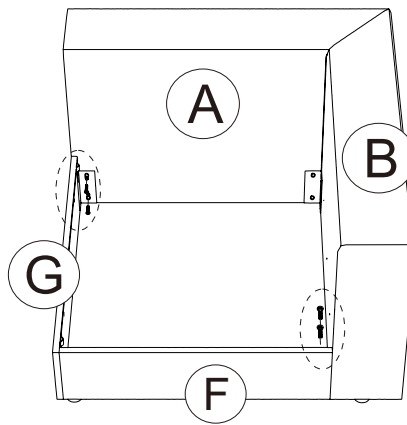

Step7

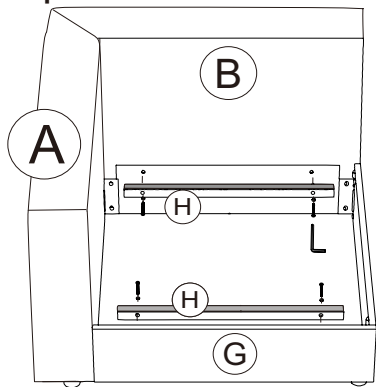

Face the Velcro upward.

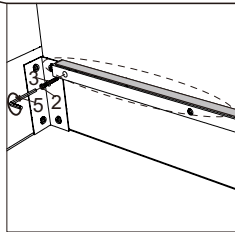

Step8

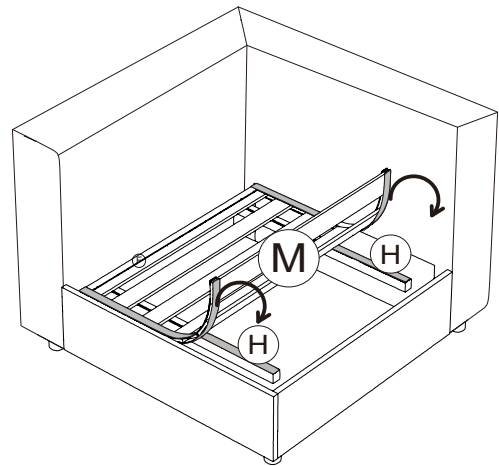

Step9

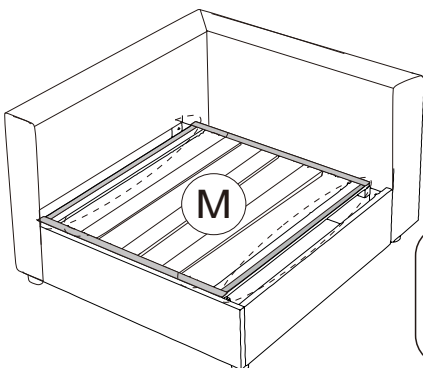

Face the Velcro upward.

Step10

