

# Installation & Assembly

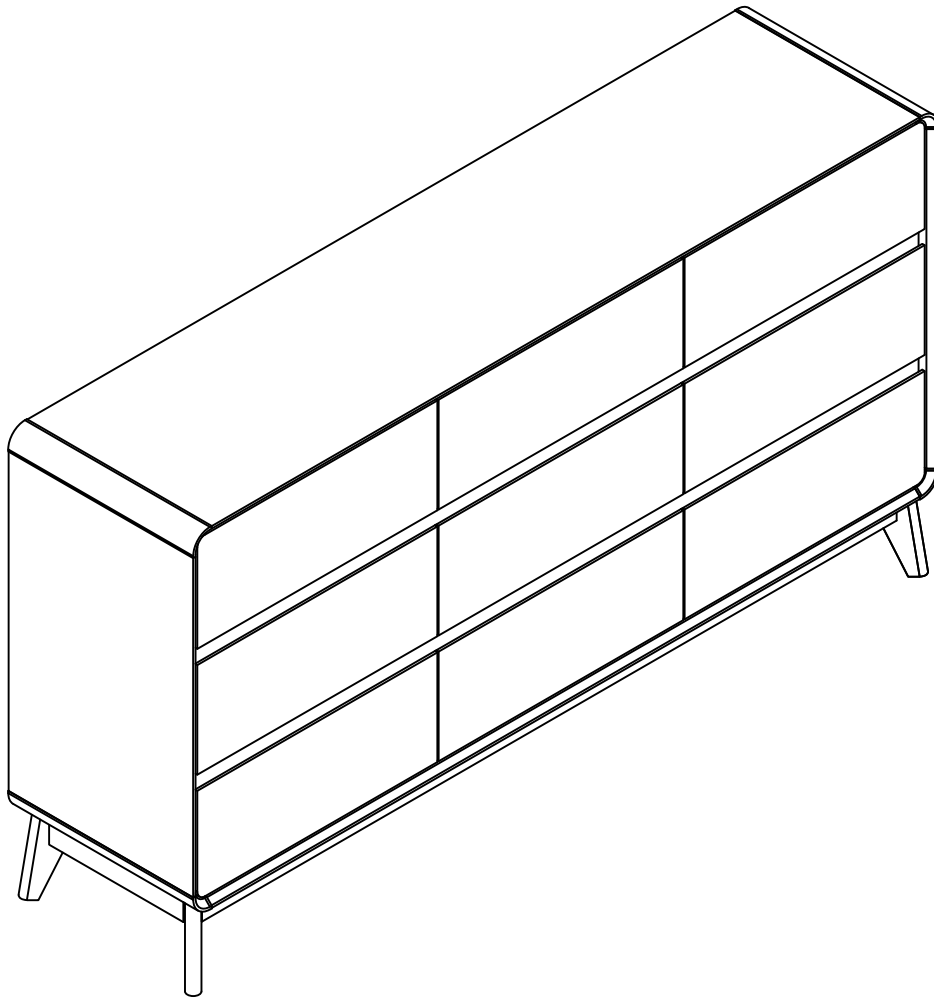

As this item contains many parts, please read the installation instruction carefully before installation. Please use tools properly and carefully. If you have any questions about the product and installation, please contact us.

Our professional after-sales team will serve you online all day.

# Before You Start

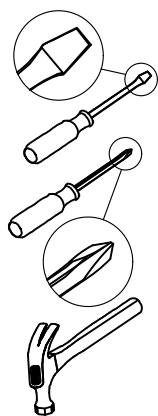

- ✓ Read through each step carefully and follow the proper order
- ✓ Separate and count all your parts and hardware
- ✓ Give yourself enough room for the assembly process
- ✓ Have the following tools: Flat Head Screwdriver, #2 Phillips Head Screwdriver and Hammer
- ✓ Caution: If using a power drill or power screwdriver for screwing, please be aware of to slow down and stop when screw is tight. Failure to do so may result in stripping the screw. (Assembly speed can be increased by using electric screwdriver)

# Helpful Hints

## PEOPLE NEEDED FOR ASSEMBLY: 1-2

- Open your item in the area you plan to keep it to avoid excessive heavy lifting.
- Identify, sort and count the parts before attempting assembly.
- Compression dowels are lightly tapped in with a hammer.
- Slides are labeled with an **R** (right) and **L** (left) for proper placement.
- Make sure to always face the point on the top of the Cam Lock towards the outer edge.
- If there is a back panel in the package, please install it to make sure your unit is complete and sturdy.
- Please fix all the screws provided for the back panel which can enhance product stability. If it is difficult to fix it when tightening, it can be fixed with the help of a hammer and then tightened.
- Do NOT use harsh chemicals or abrasive cleaners on this item.
- Never push, pull, or drag your furniture.



---

# Board Identification

Not actual size

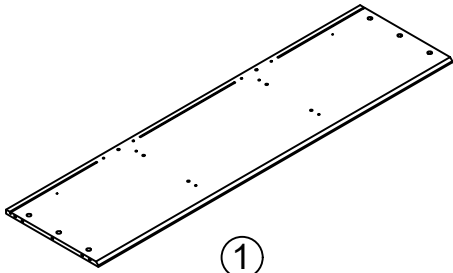

①  
TOP  
Qty:1

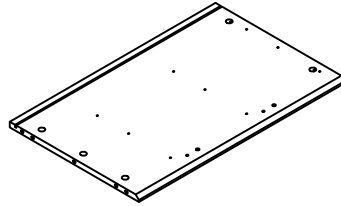

②  
LEFT SIDE PANEL  
Qty:1

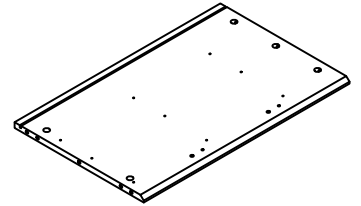

③  
RIGHT SIDE PANEL  
Qty:1

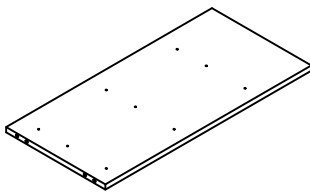

④  
MIDDLE PANEL  
Qty:2

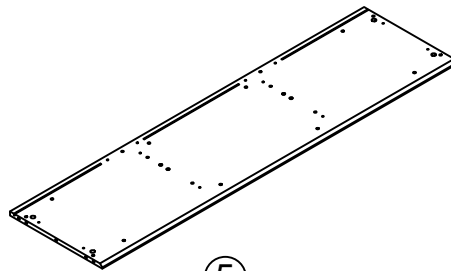

⑤  
BOTTOM FRAME  
Qty:1

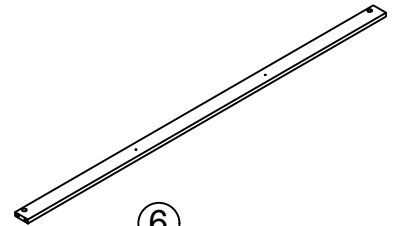

⑥  
FRONT SLAT  
Qty:2

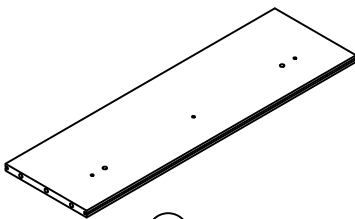

⑦  
BACK SLAT  
Qty:2

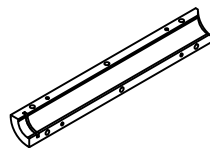

⑧  
CONNECTION RAIL  
Qty:2

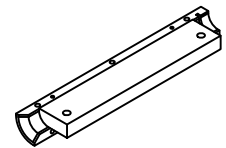

⑨  
CONNECTION RAIL  
Qty:1

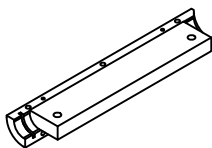

⑩  
CONNECTION RAIL  
Qty:1

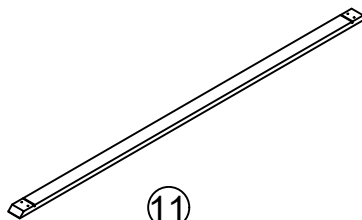

⑪  
REAR FOOT STRIP  
Qty:2

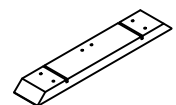

⑫  
SIDE FOOT STRIP  
Qty:2

# Board Identification

Not actual size



⑬

LEG  
Qty:4

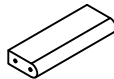

⑭

LEG  
Qty:2

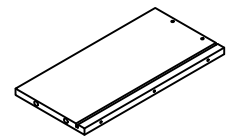

⑮

DRAWER LEFT SIDE  
Qty:9

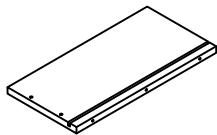

⑯

DRAWER RIGHT SIDE  
Qty:9

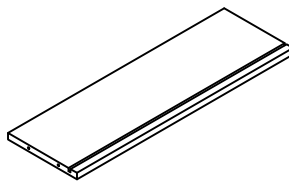

⑰

DRAWER BACK PANEL  
Qty:9

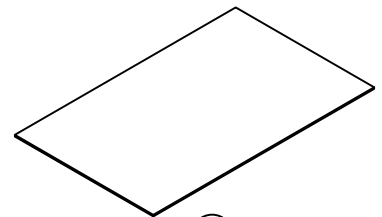

⑱

DRAWER BOTTOM PANEL  
Qty:9

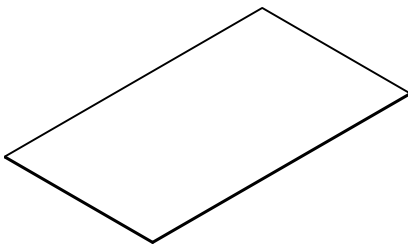

⑲

BACK PANEL  
Qty:1

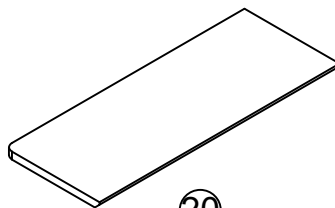

⑳

DRAWER FRONT PANEL  
Qty:1

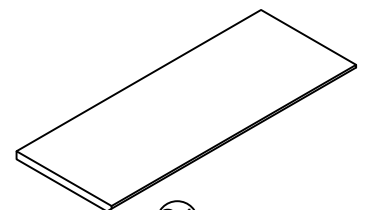

㉑

DRAWER FRONT PANEL  
Qty:1

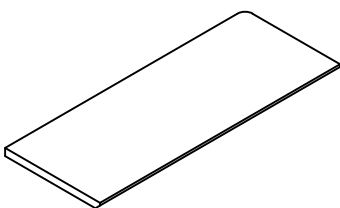

㉒

DRAWER FRONT PANEL  
Qty:1

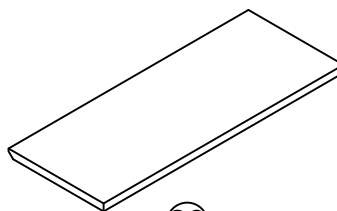

㉓

DRAWER FRONT PANEL  
Qty:1

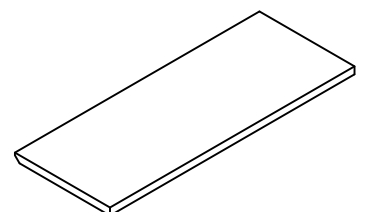

㉔

DRAWER FRONT PANEL  
Qty:1

---

# Board Identification

Not actual size

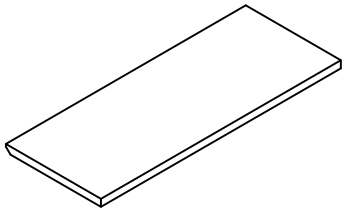

25

DRAWER FRONT PANEL  
Qty:1

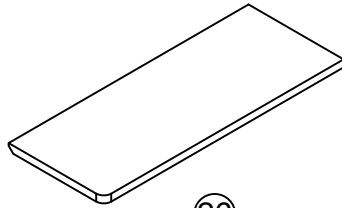

26

DRAWER FRONT PANEL  
Qty:1

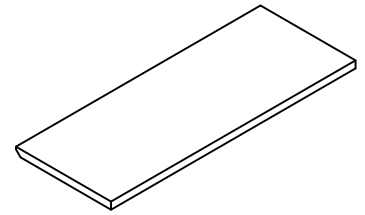

27

DRAWER FRONT PANEL  
Qty:1

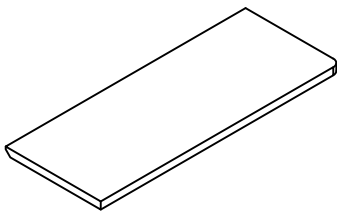

28

DRAWER FRONT PANEL  
Qty:1

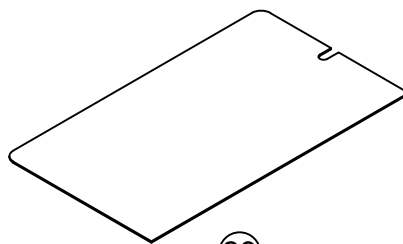

29

BACK PANEL  
Qty:2

# Board Identification

Not actual size

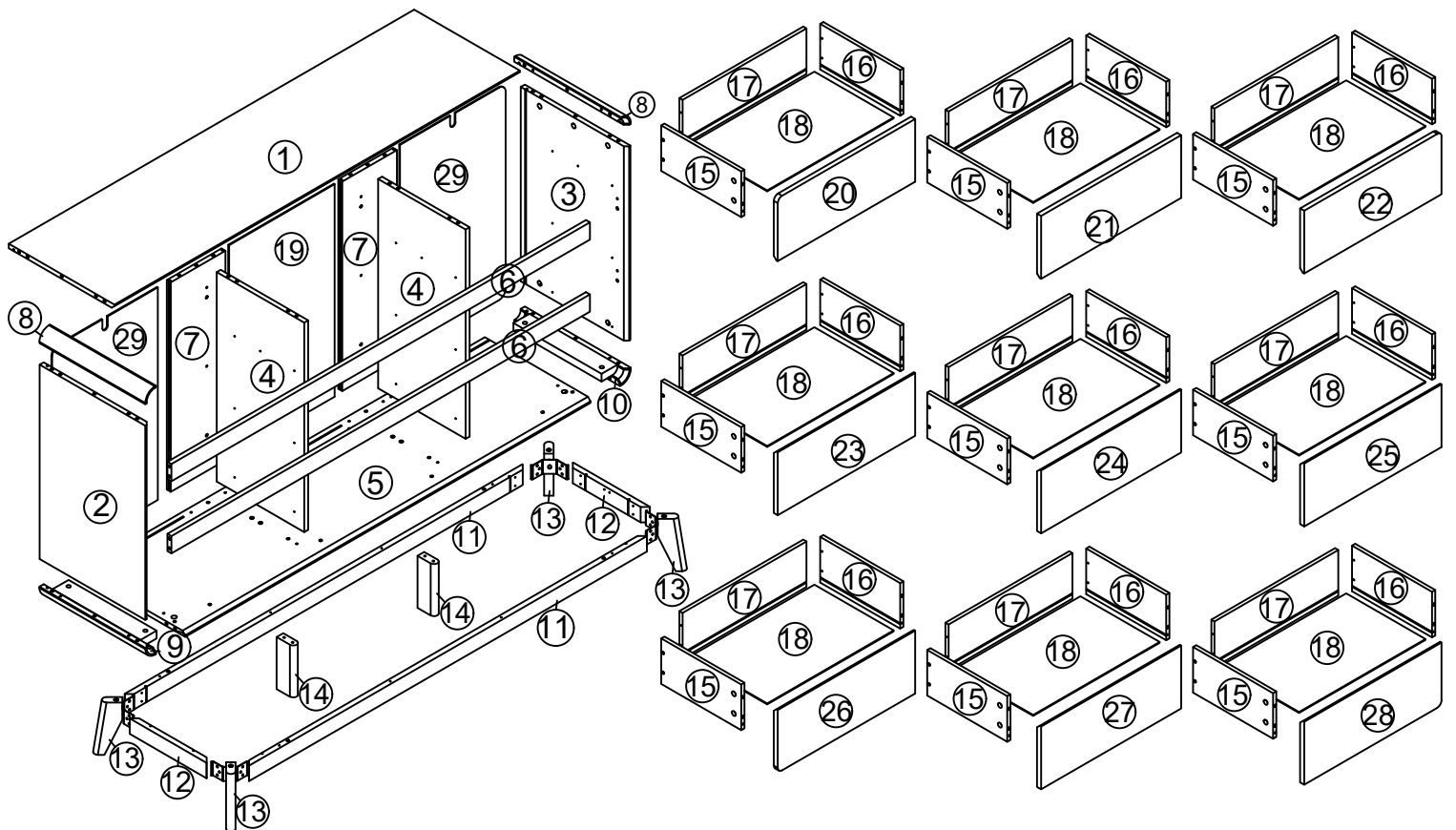

# Part List

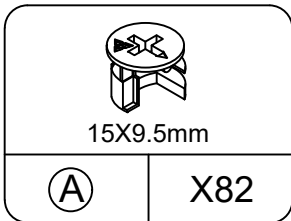

CAM LOCK  
spare:3

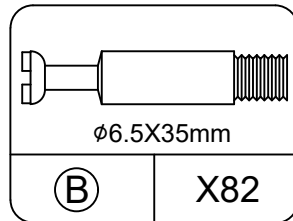

CAM BOLT  
spare:3

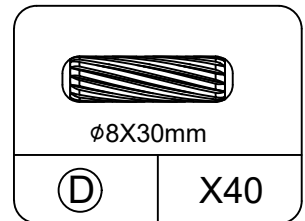
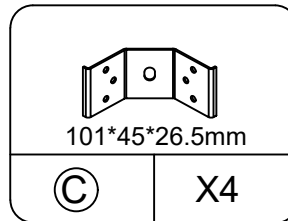

WOOD DOWEL  
spare:3

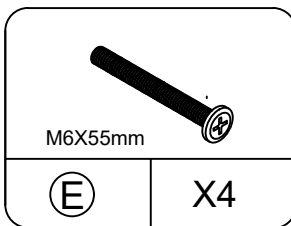

SCREW  
spare:1

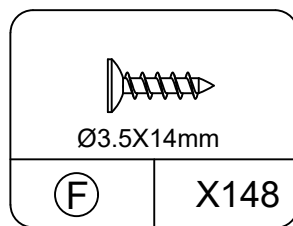

SCREW  
spare:3

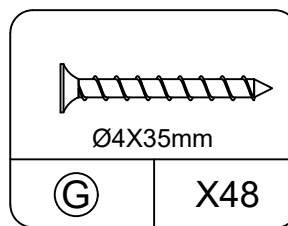

SCREW  
spare:3

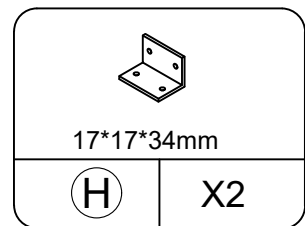

METAL PLATE

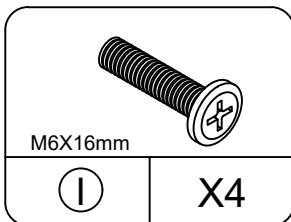

SCREW  
spare:1

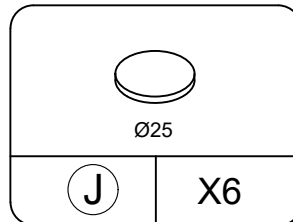

FLOOR-MATS  
spare:1

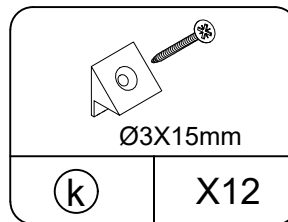

BACK PANEL BUCKLE  
spare:2

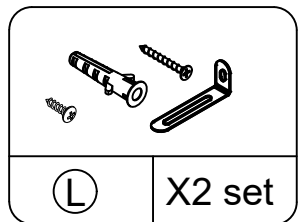

TIPPING RESTRAINT  
HARDWARE KIT

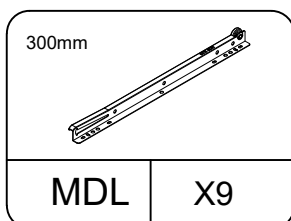

LEFT DRAWER RUNNER

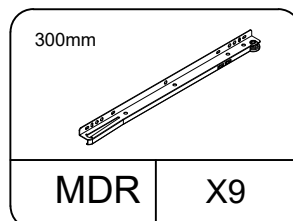

RIGHT DRAWER RUNNER

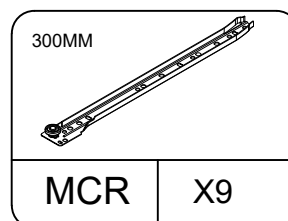

RIGHT CABINET MEMBER

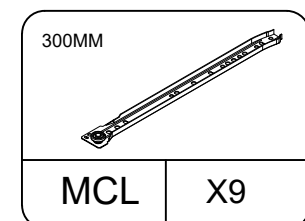

LEFT CABINET MEMBER

# Part List

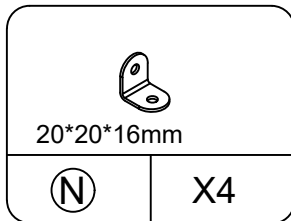

METAL PLATE

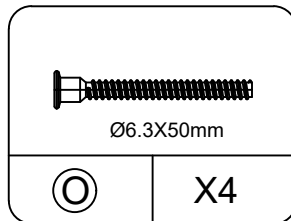

SCREW  
spare:1

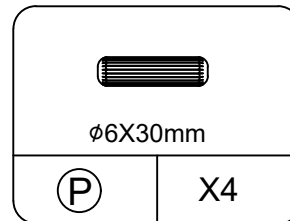

WOOD DOWEL  
spare:1

Insert the cam bolt into the hole first, then insert the cam lock and lock it.

## Cam Lock Fastening System

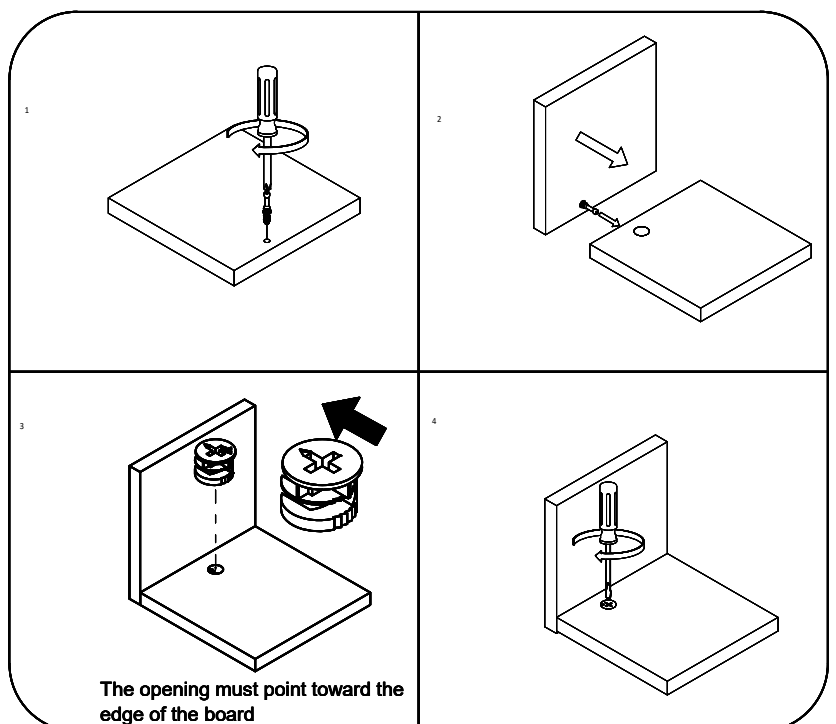

# STEP 1

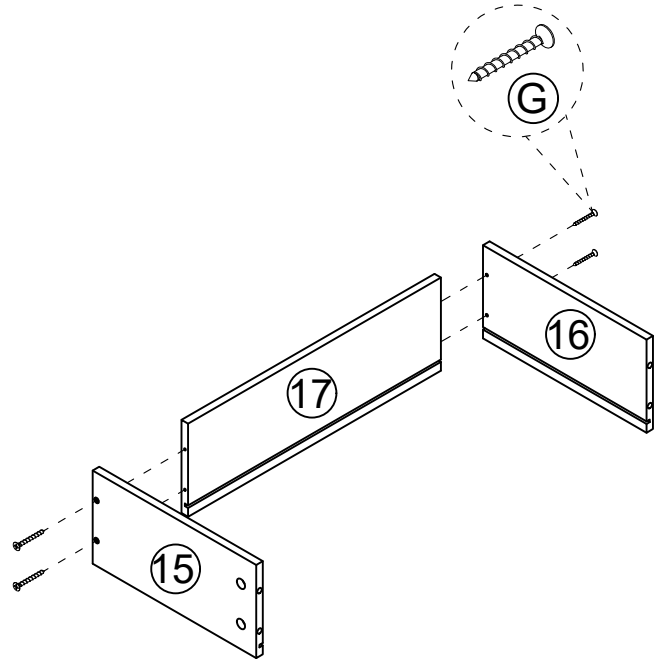
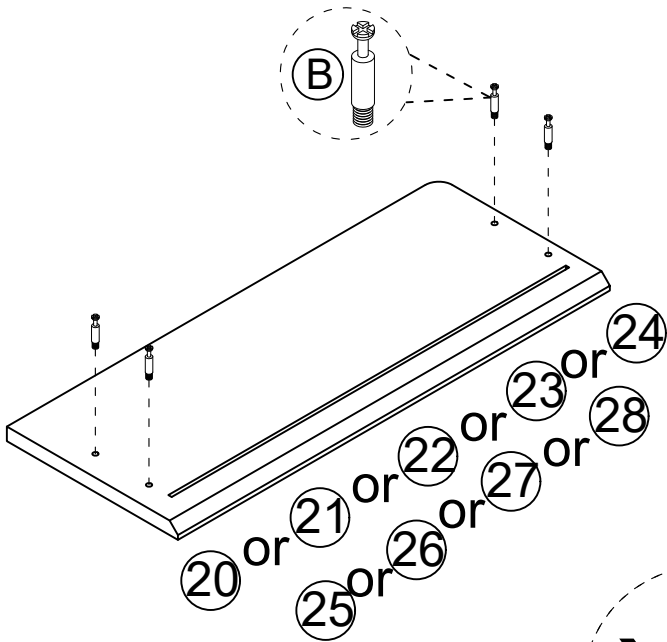
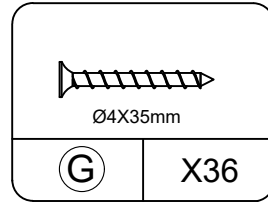
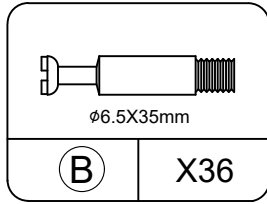
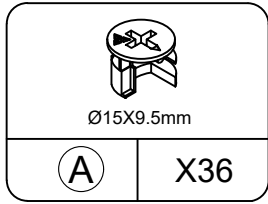
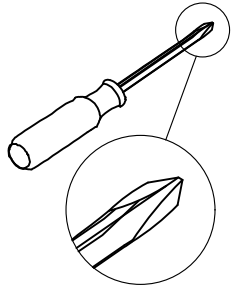

X 9

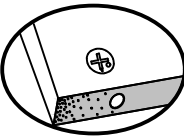
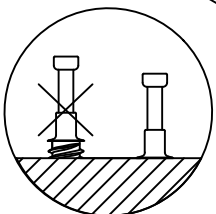
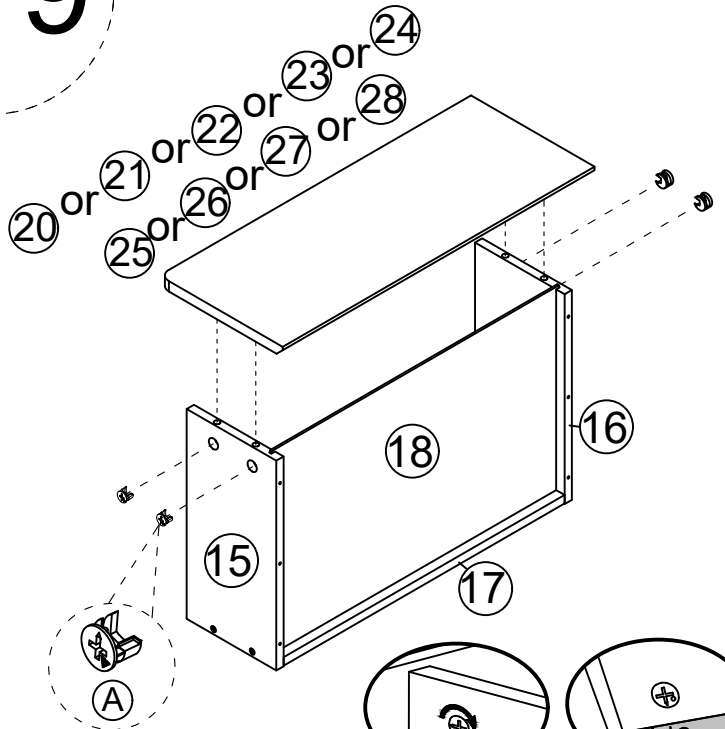
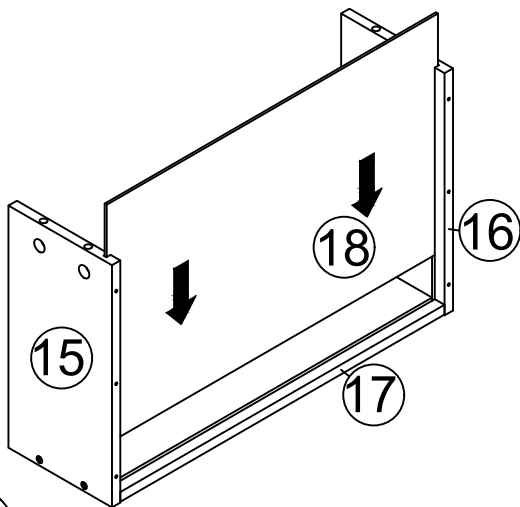

# STEP 2

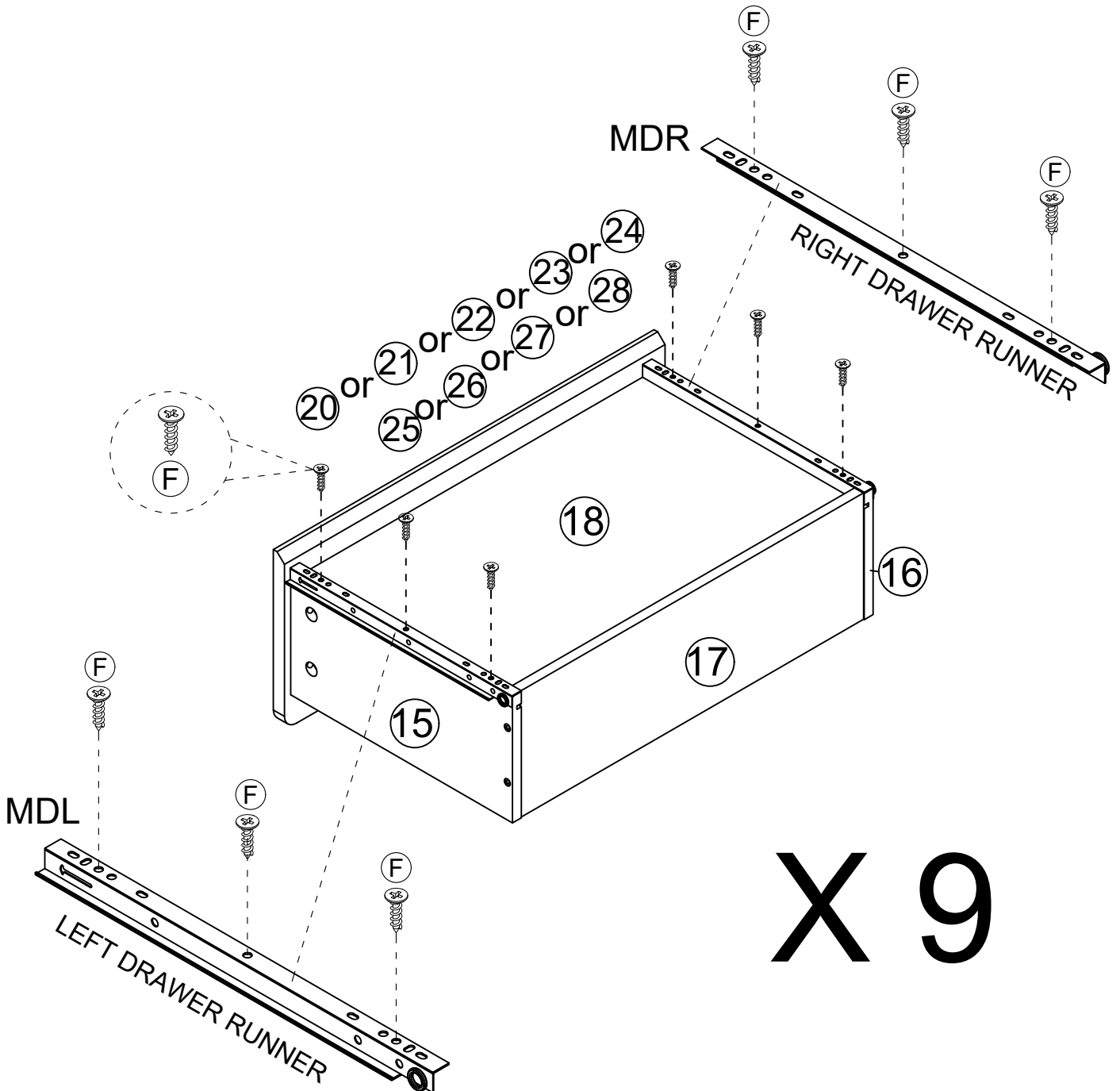
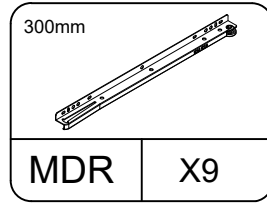
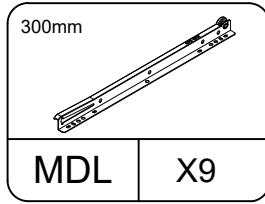
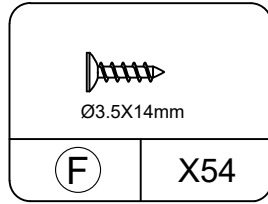
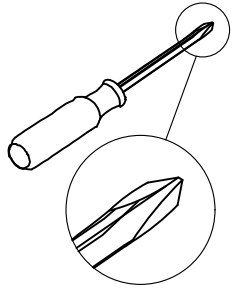

# STEP 3

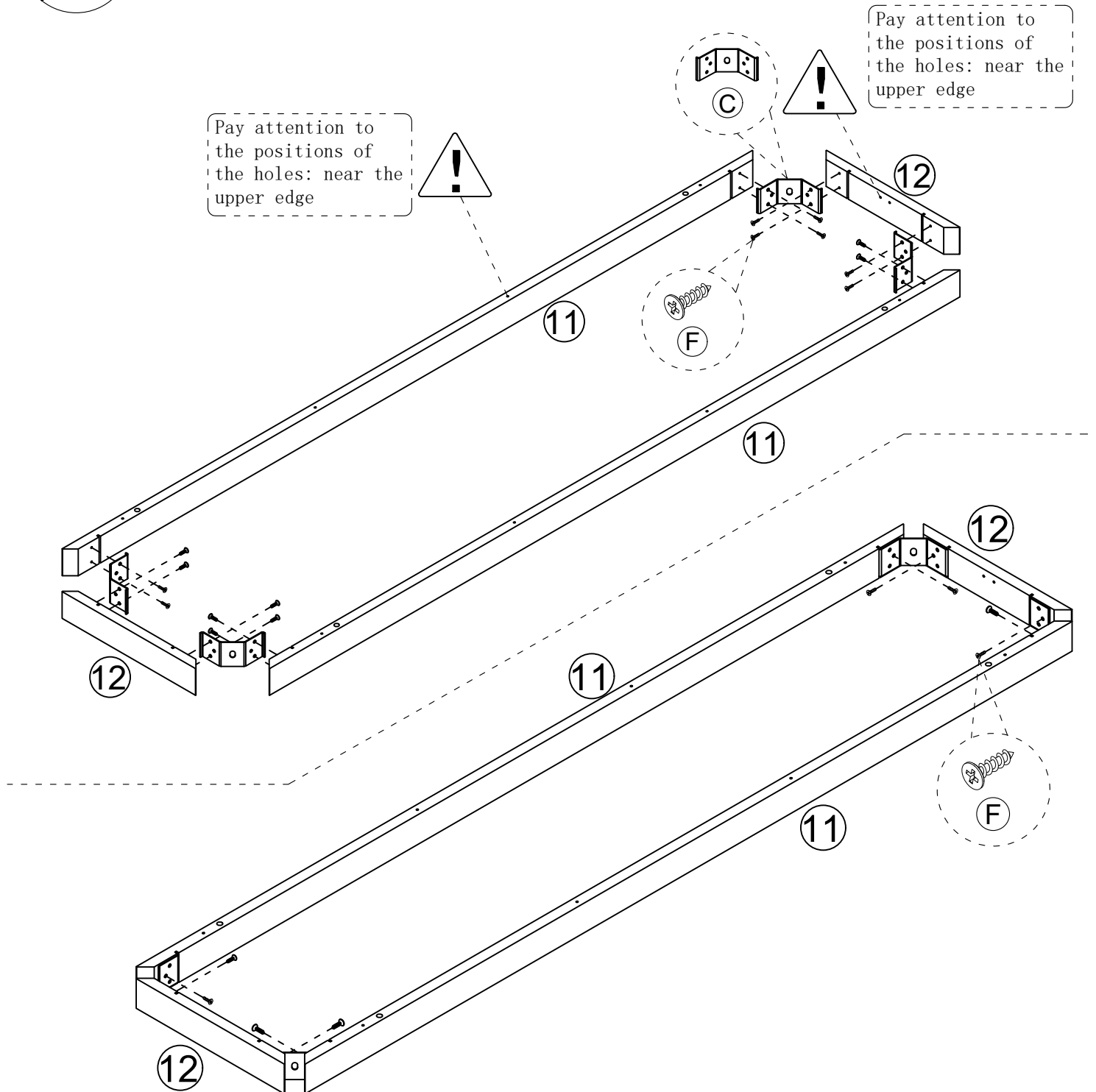
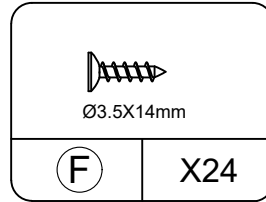
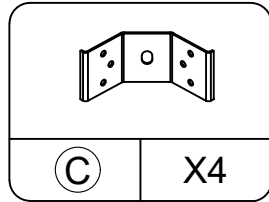
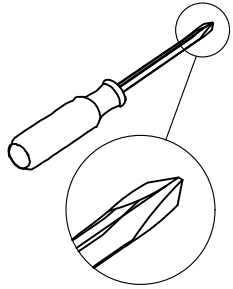

# STEP 4

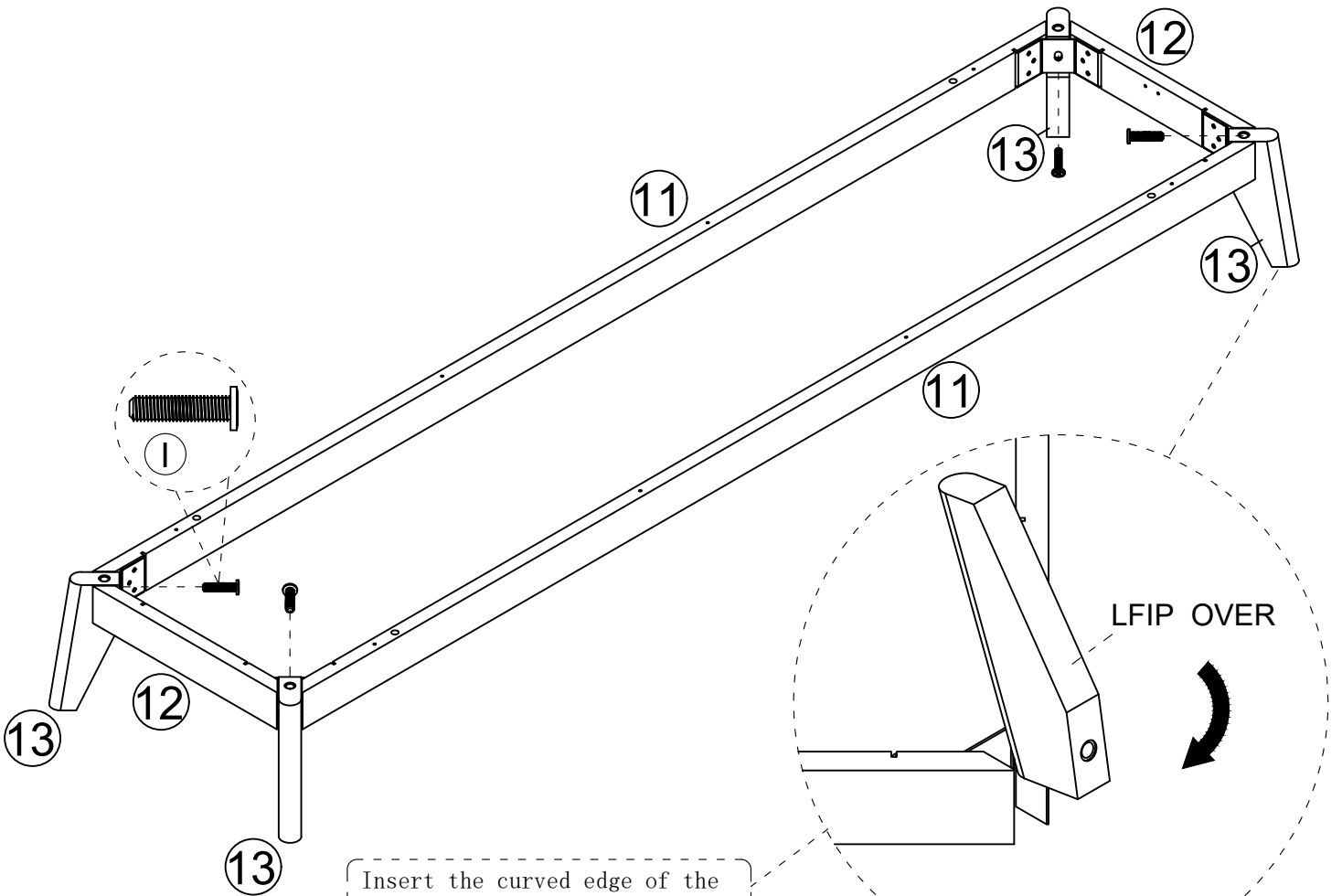
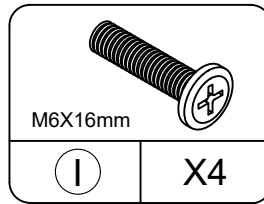
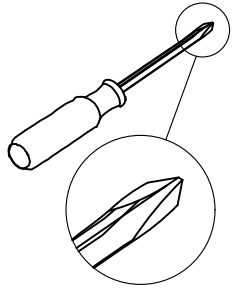

Insert the curved edge of the foot into the gap between Part 11 and Part 12. Then rotate the foot downward to the correct position so that the top of the foot aligns with the rails. Meanwhile, the hole in the foot will also align with the hole in the metal piece.

# STEP 5

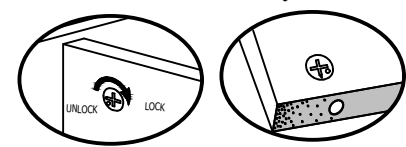
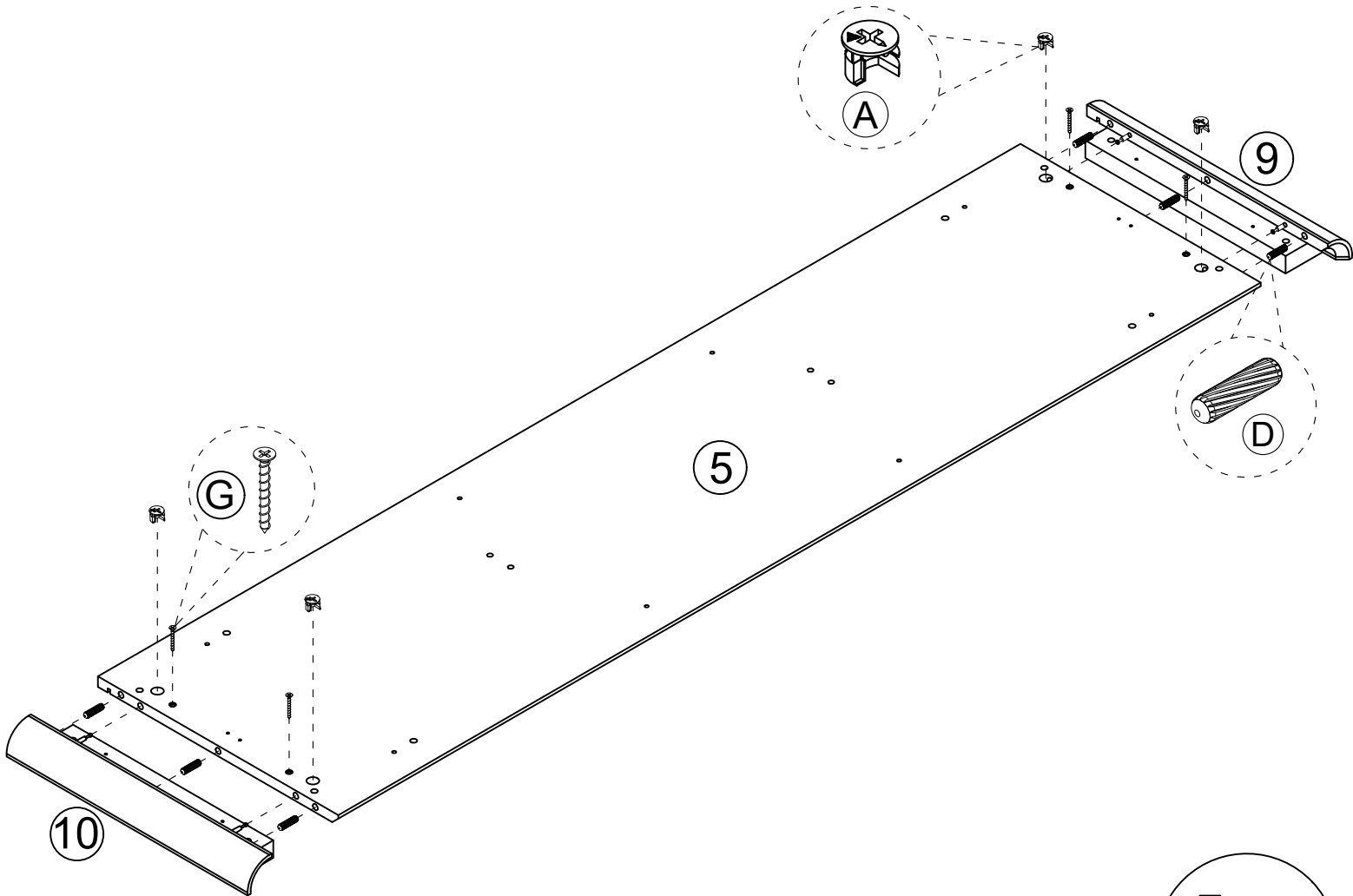
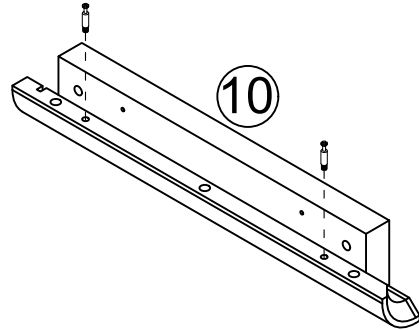
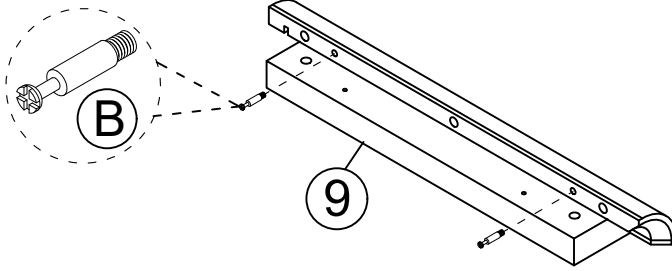
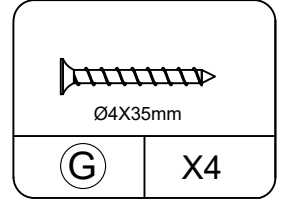
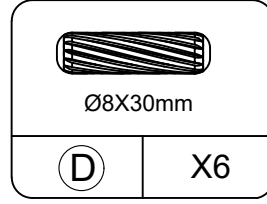
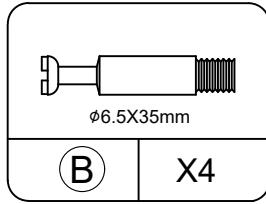
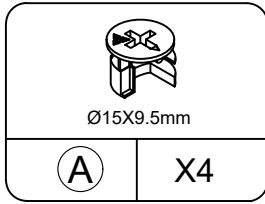
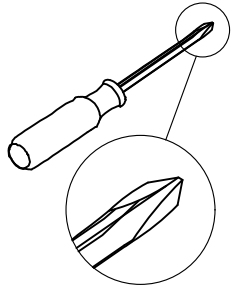

Proper orientation of CAM LOCK

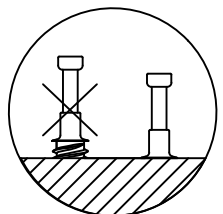

# STEP 6

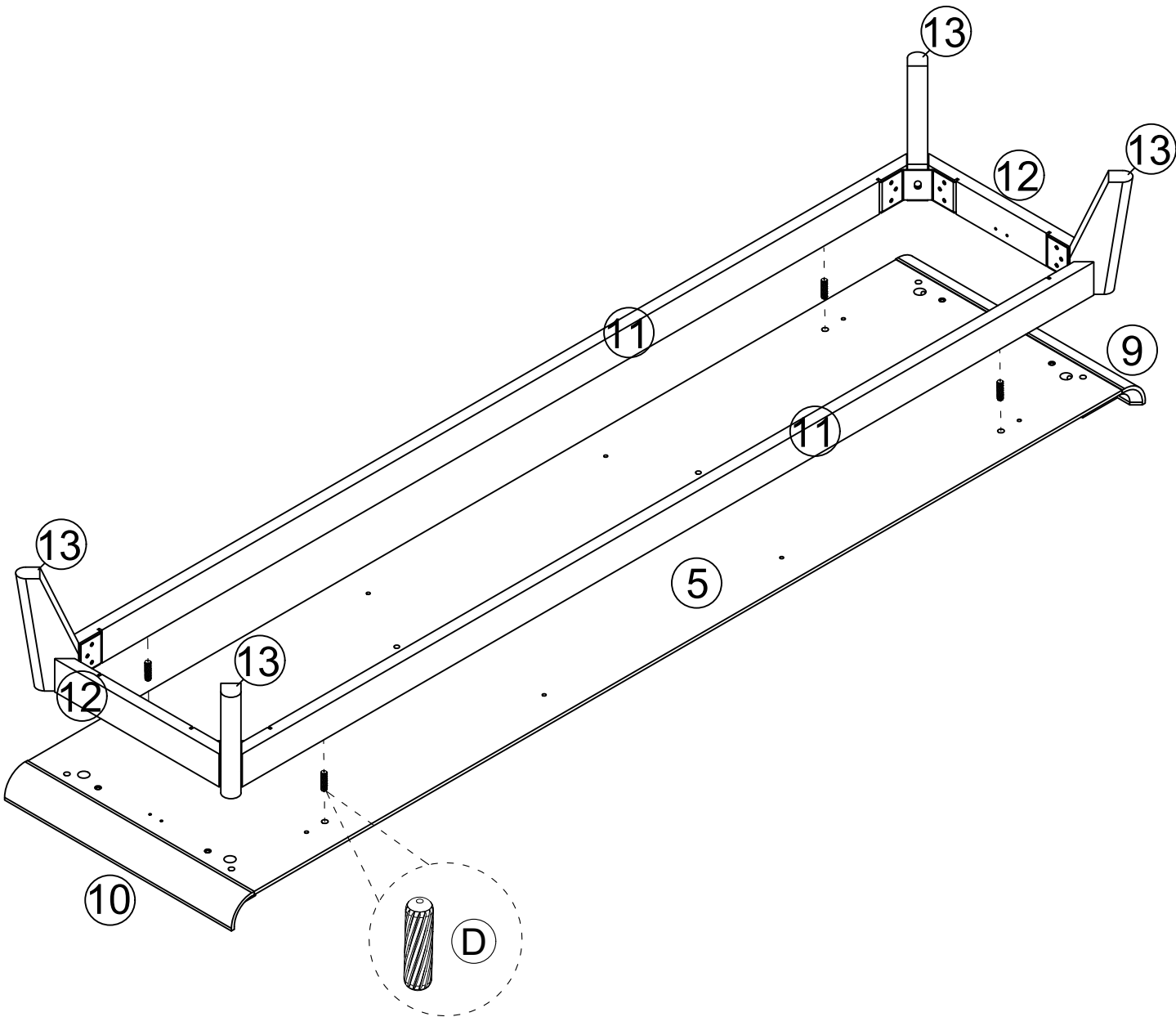
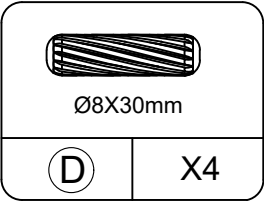
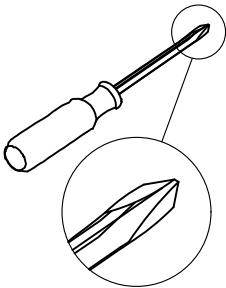

# STEP 7

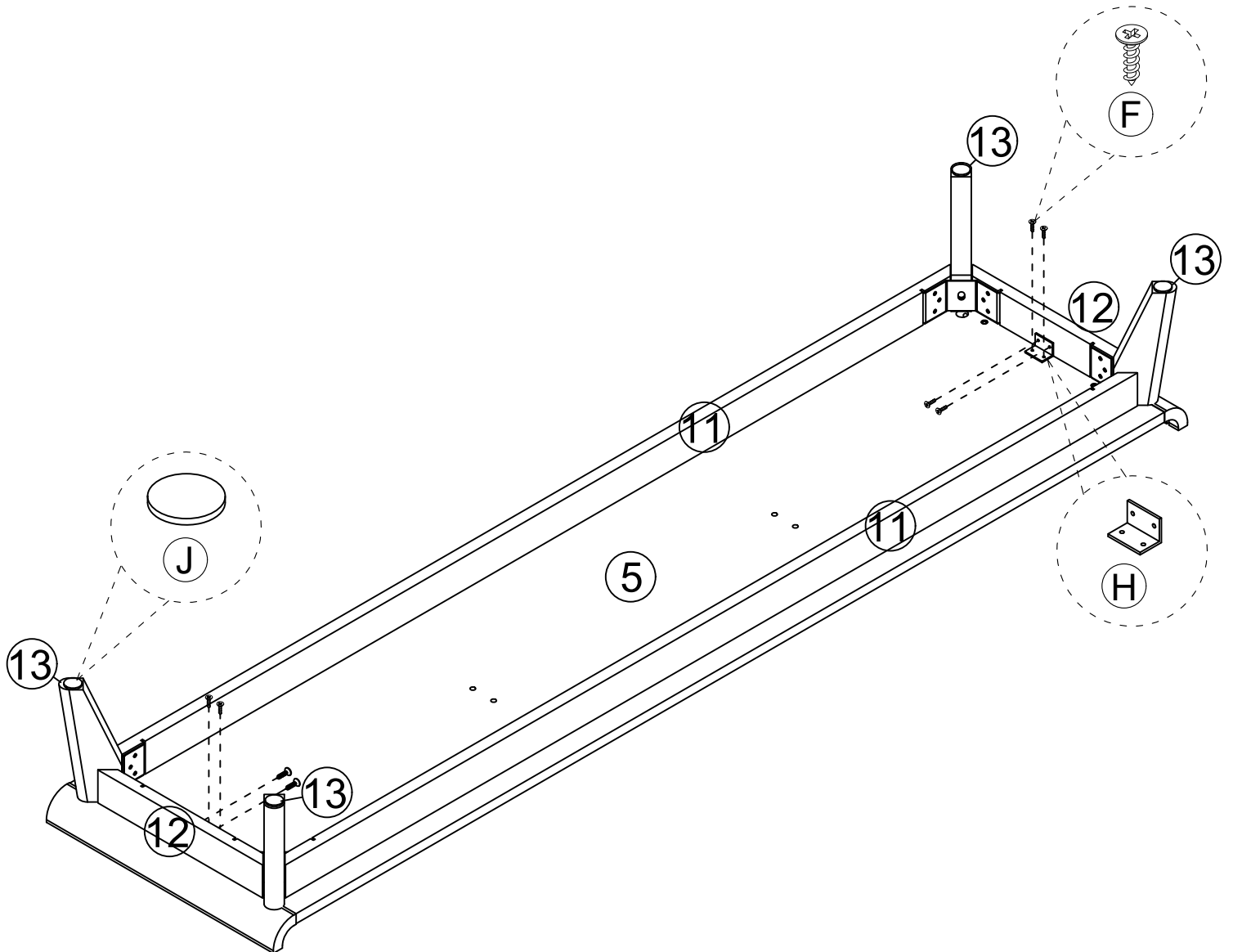
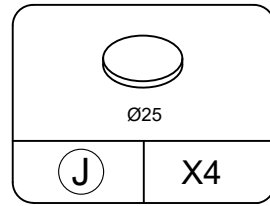
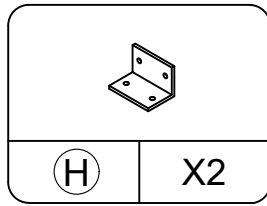
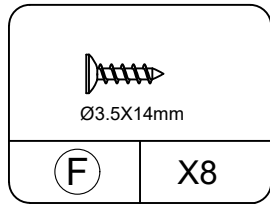
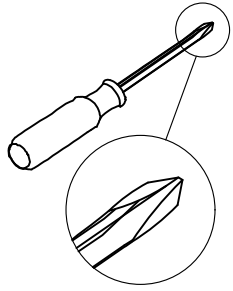

# STEP 8

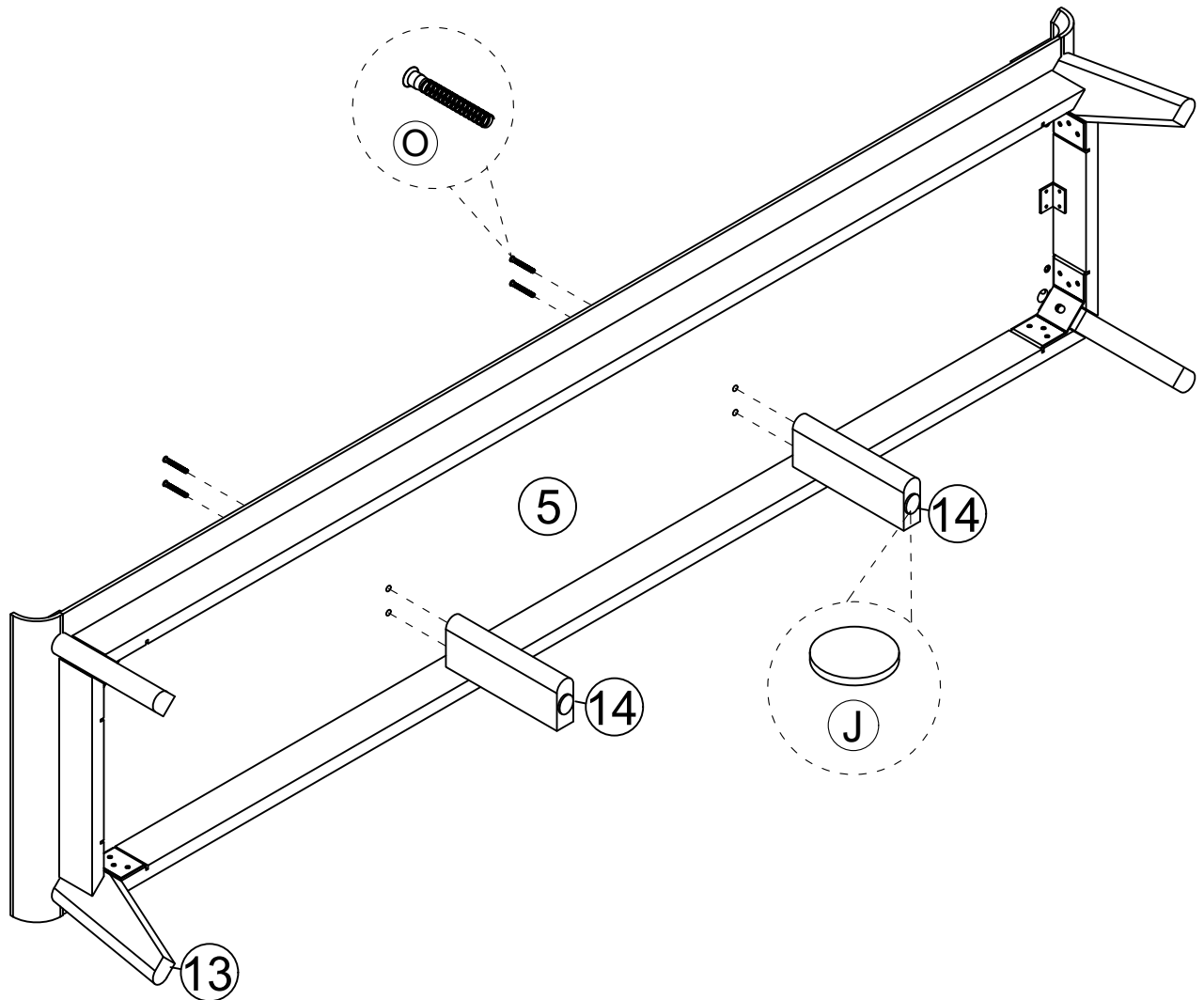
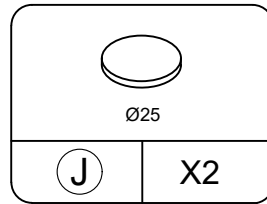
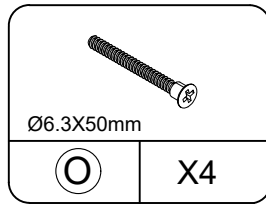
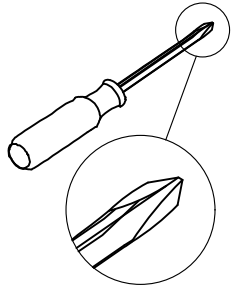

# STEP 9

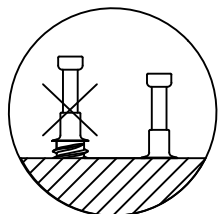
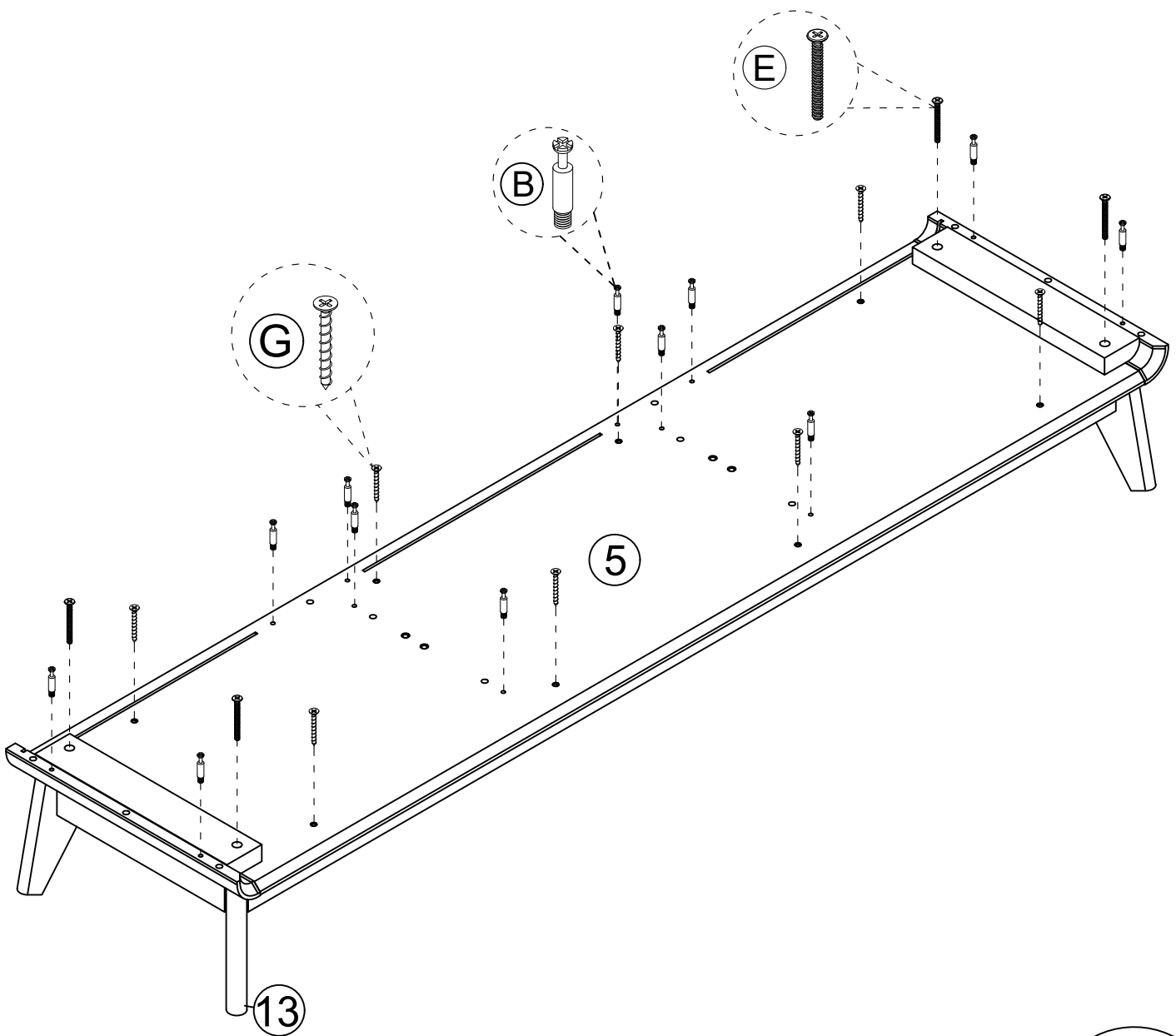
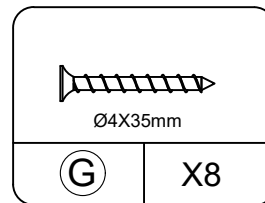
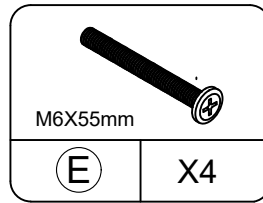
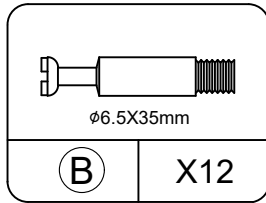
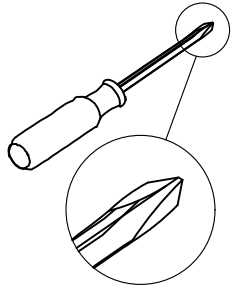

# STEP 10

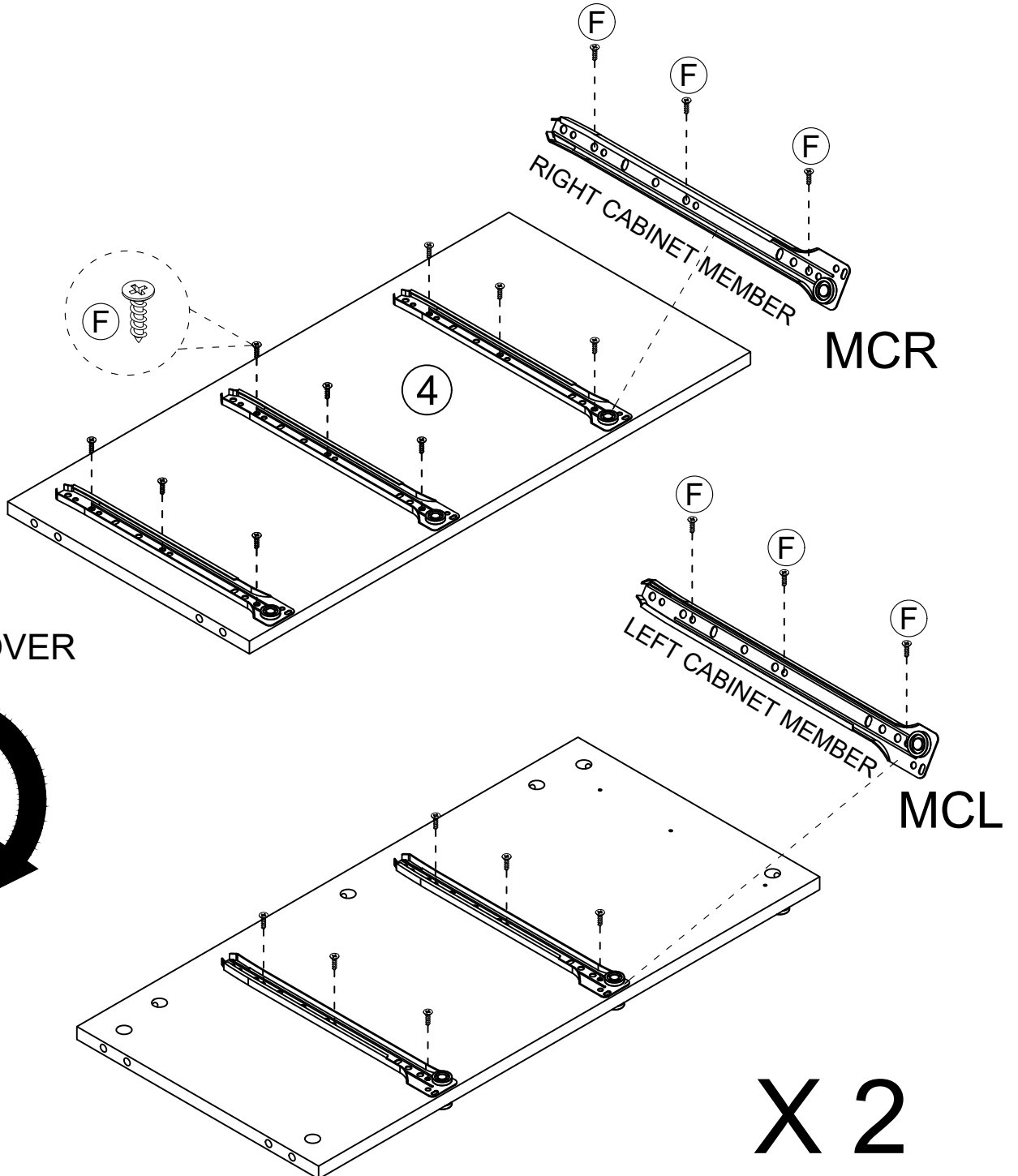
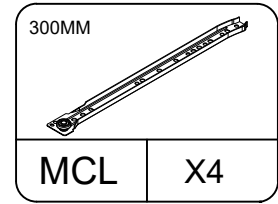
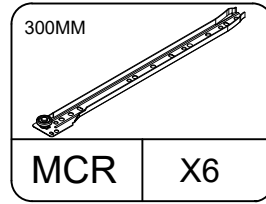
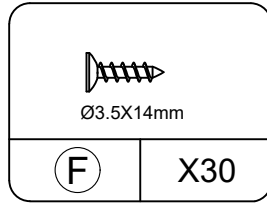
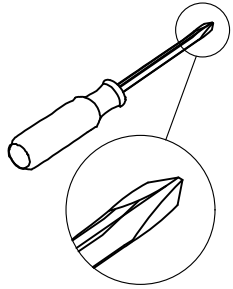

# STEP 11

---

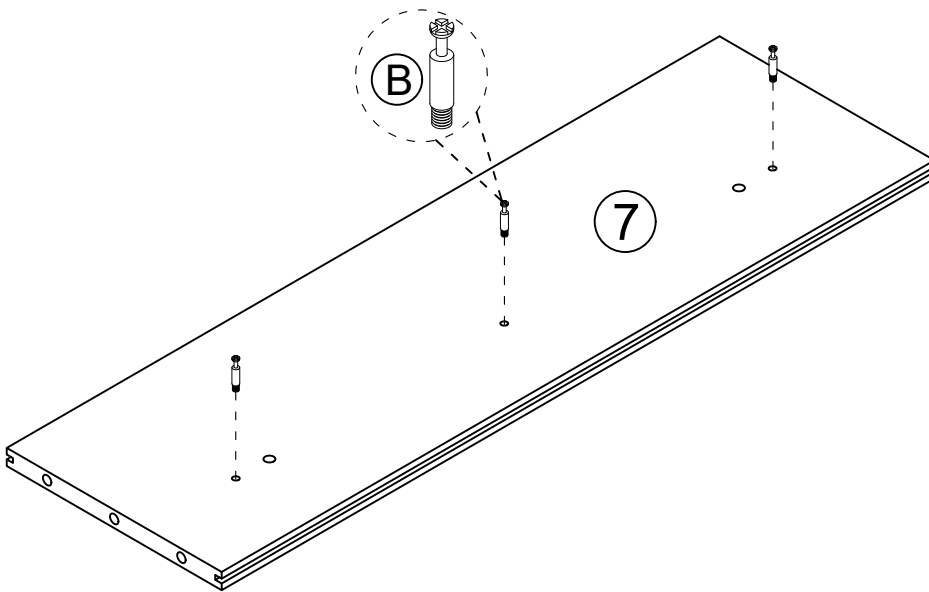
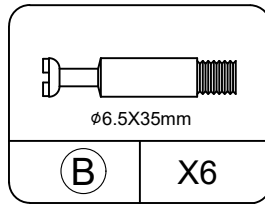
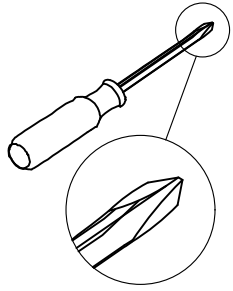

X 2

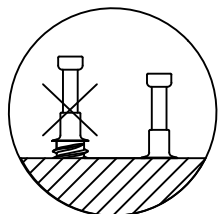

# STEP 12

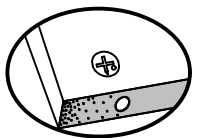
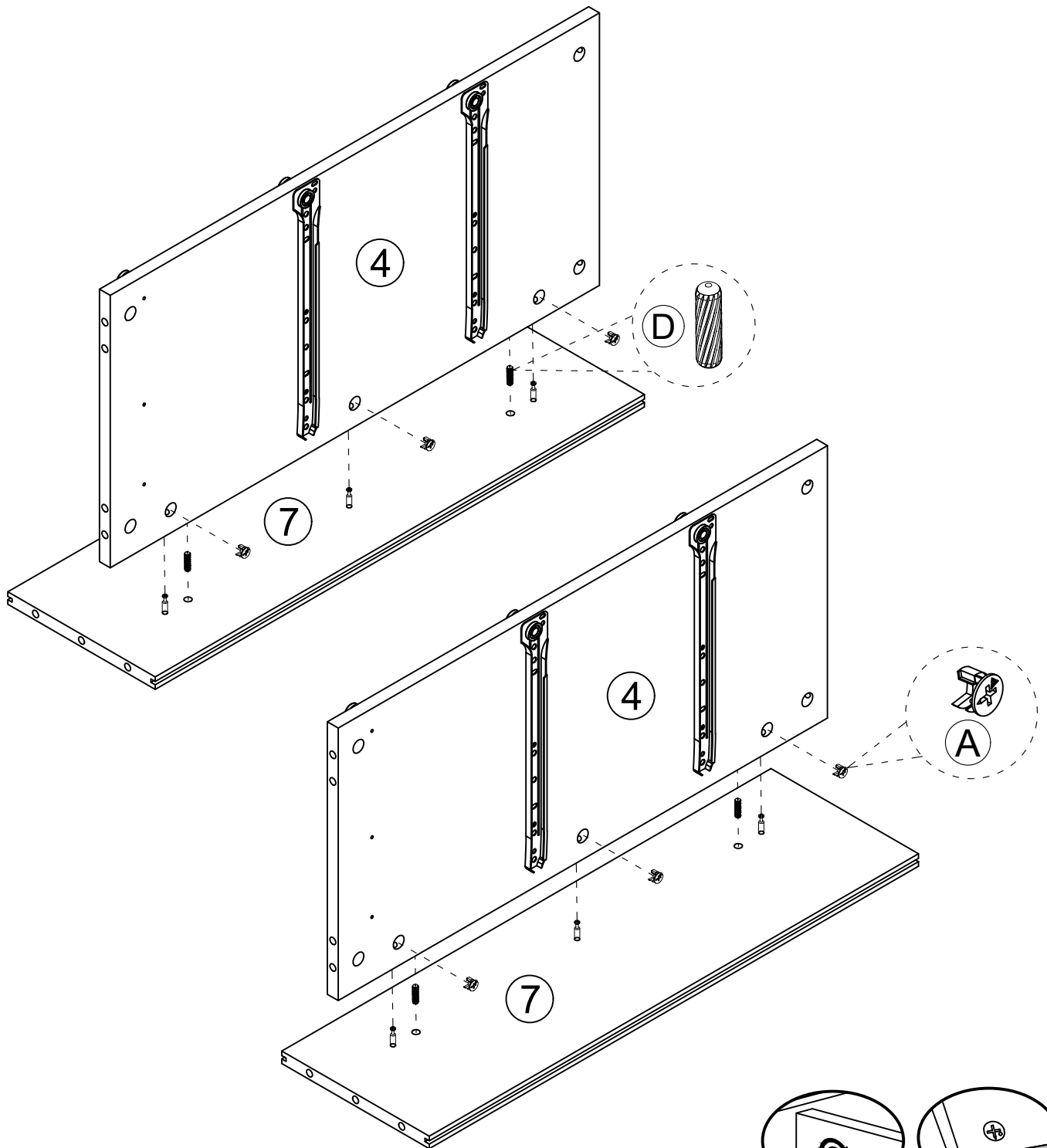
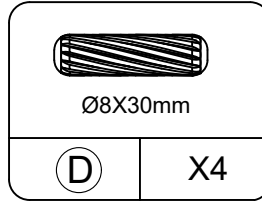
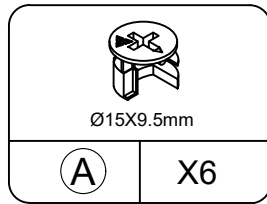
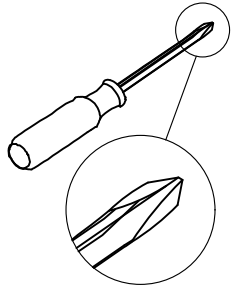

Proper orientation of CAM LOCK

# STEP 13

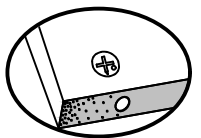
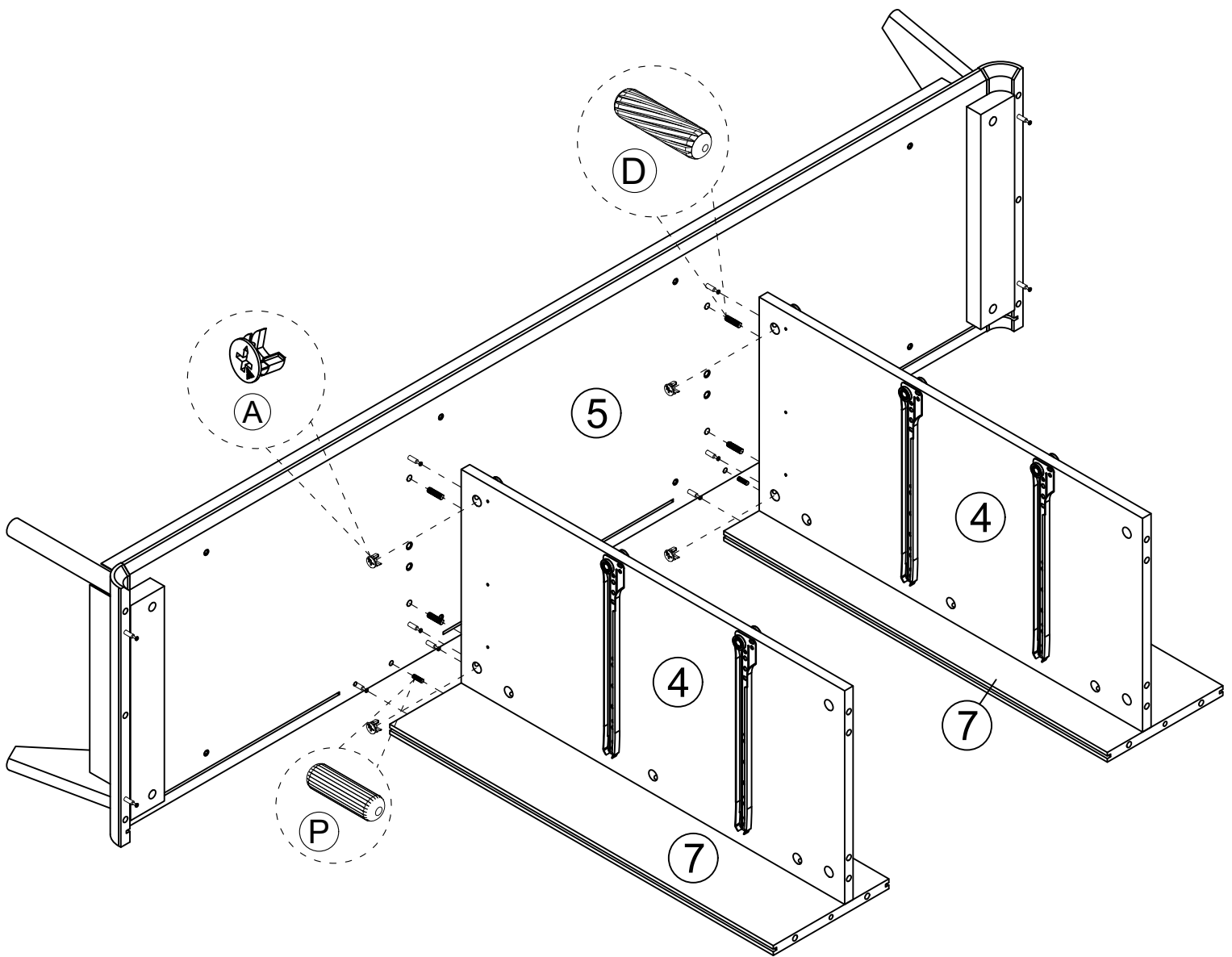
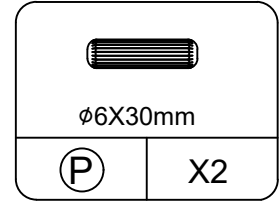
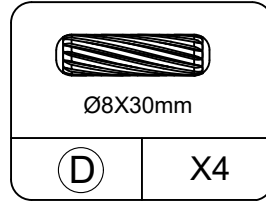
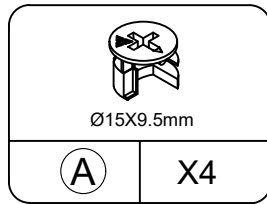
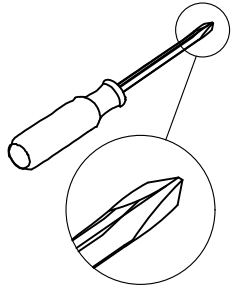

# STEP 14

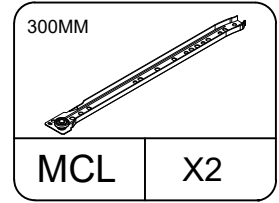
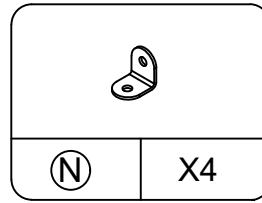
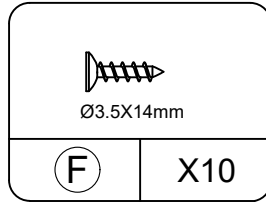
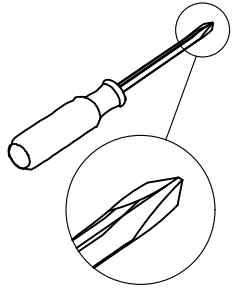

X 2

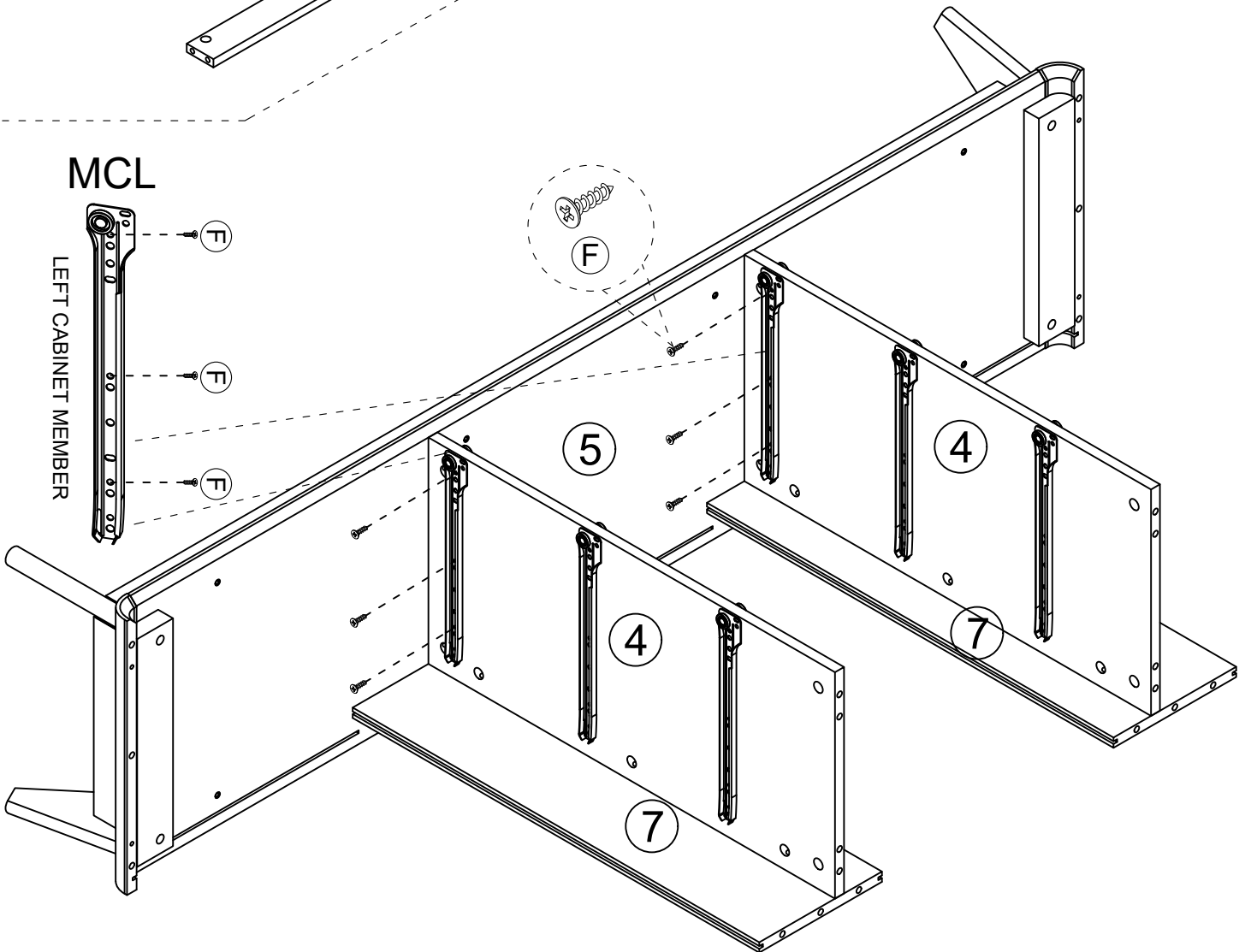
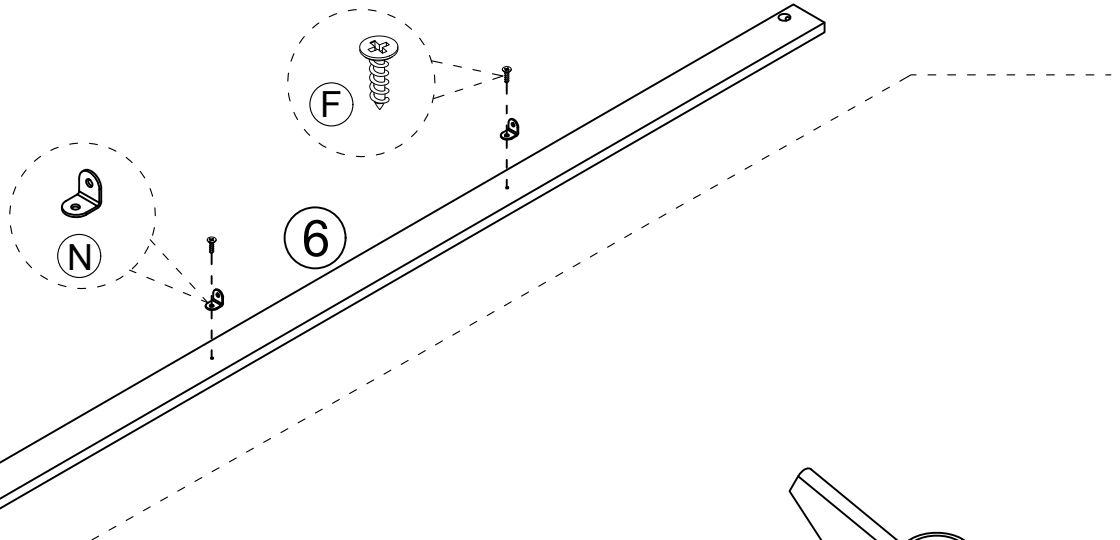

# STEP 15

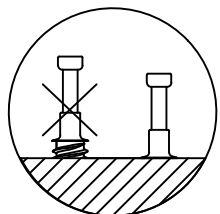
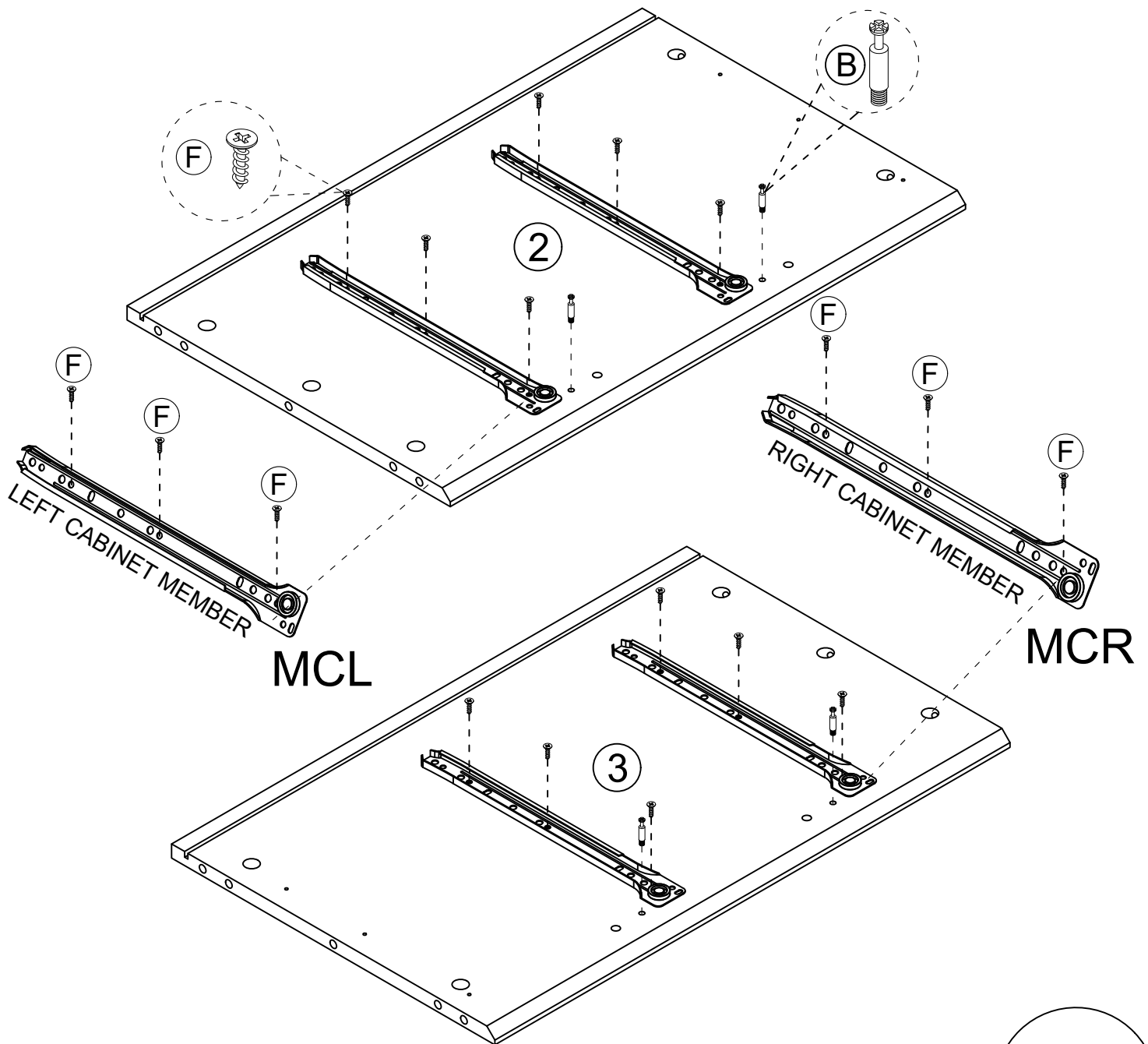
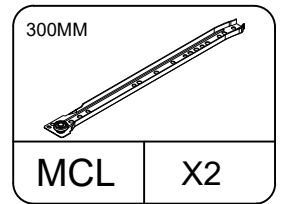
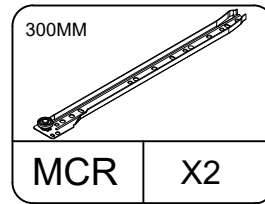
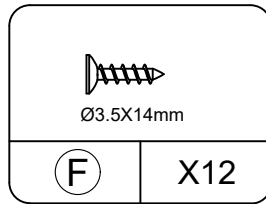
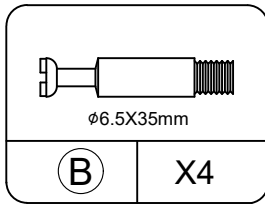
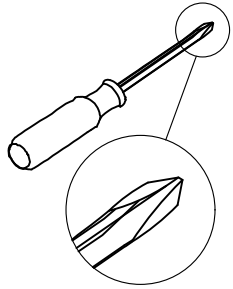

# STEP 16

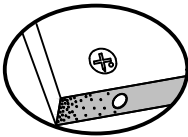
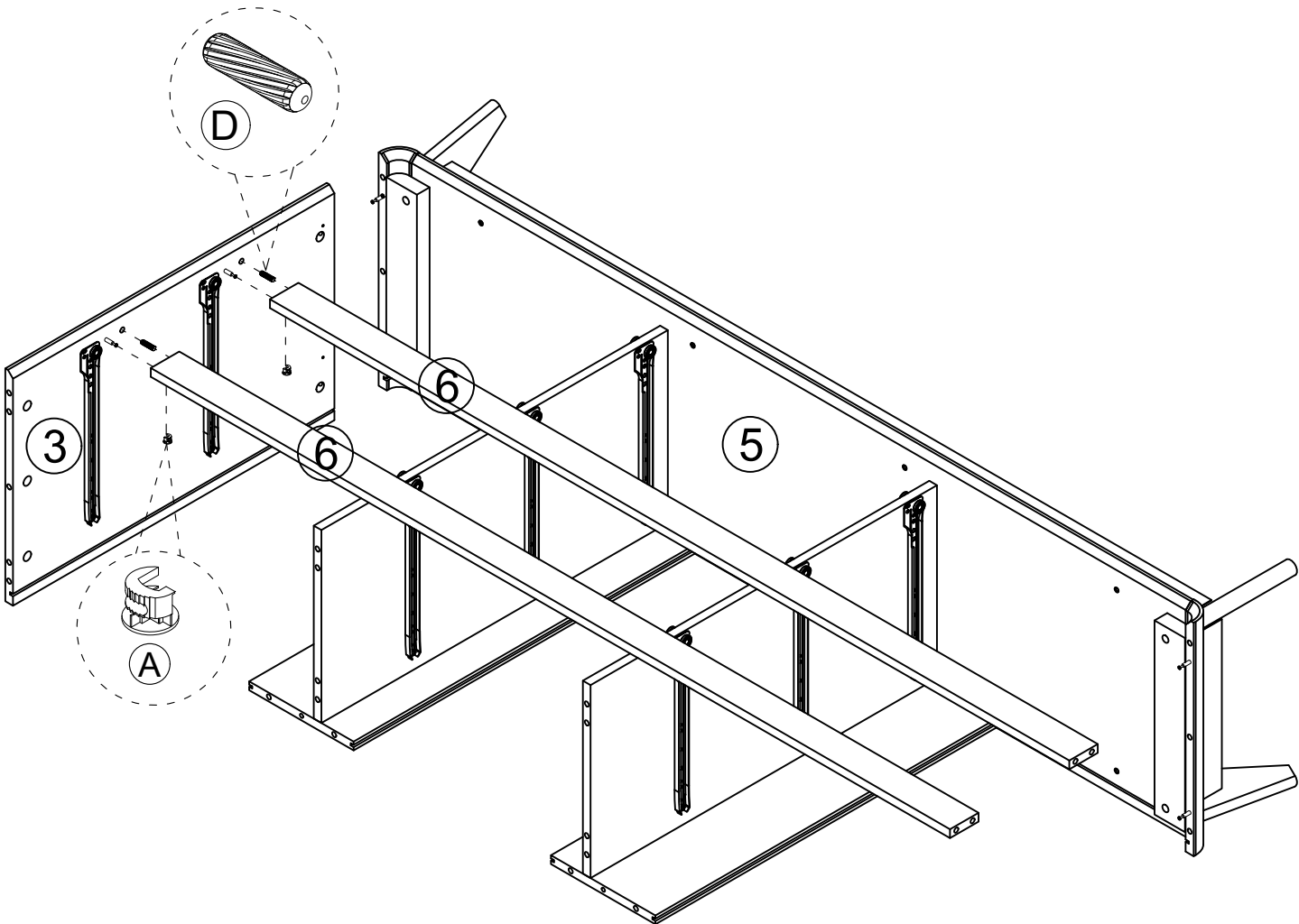
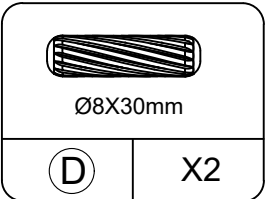
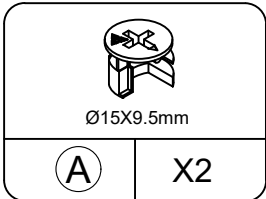
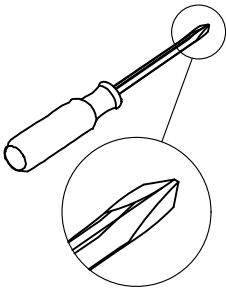

Proper orientation of CAM LOCK

# STEP 17

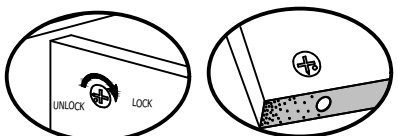
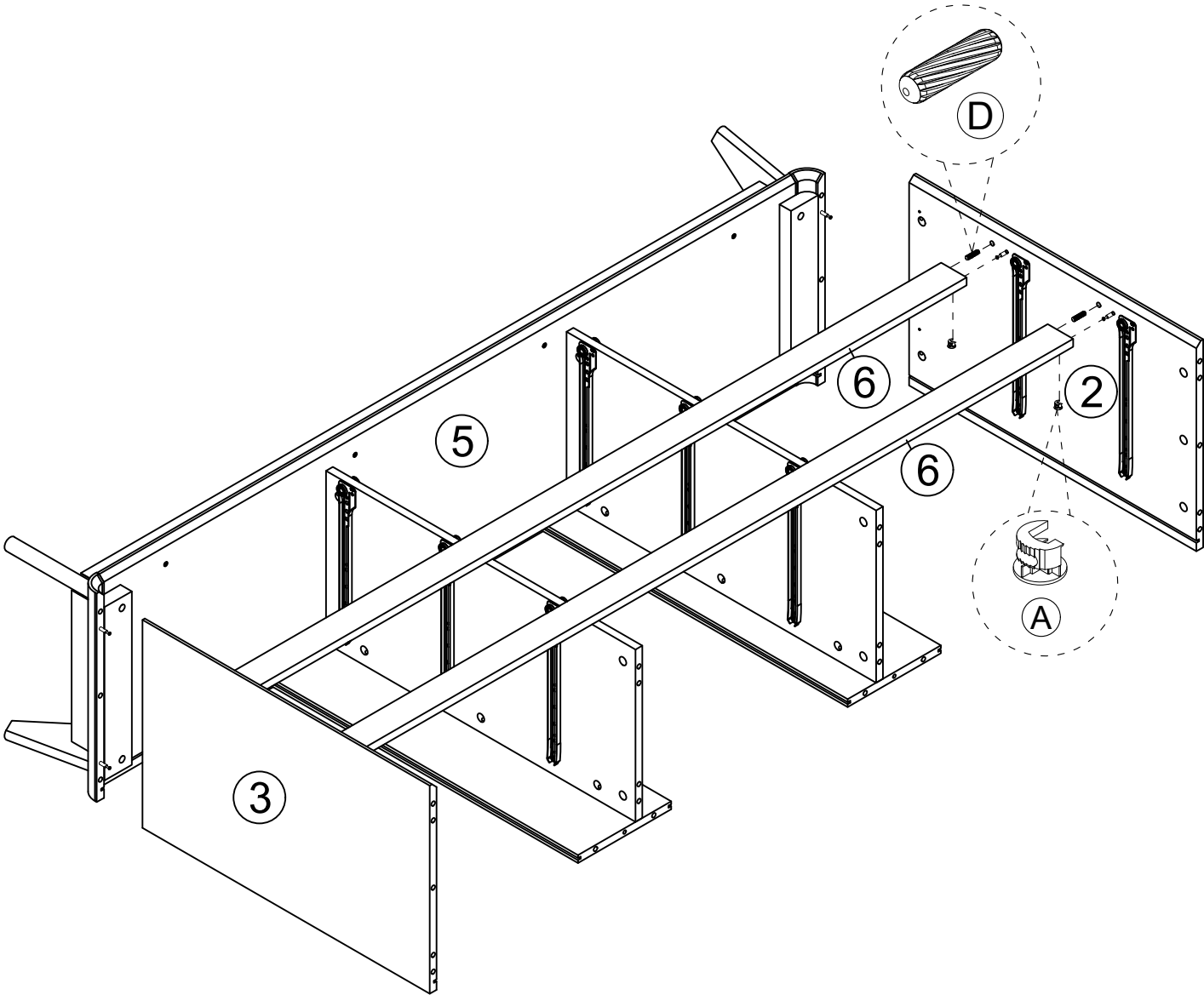
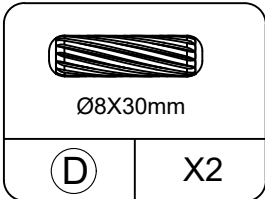
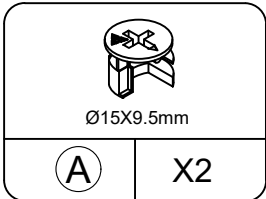
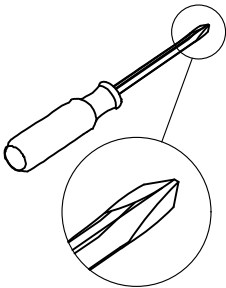

# STEP 18

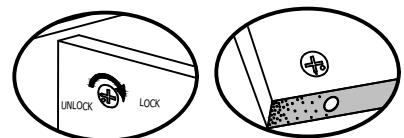
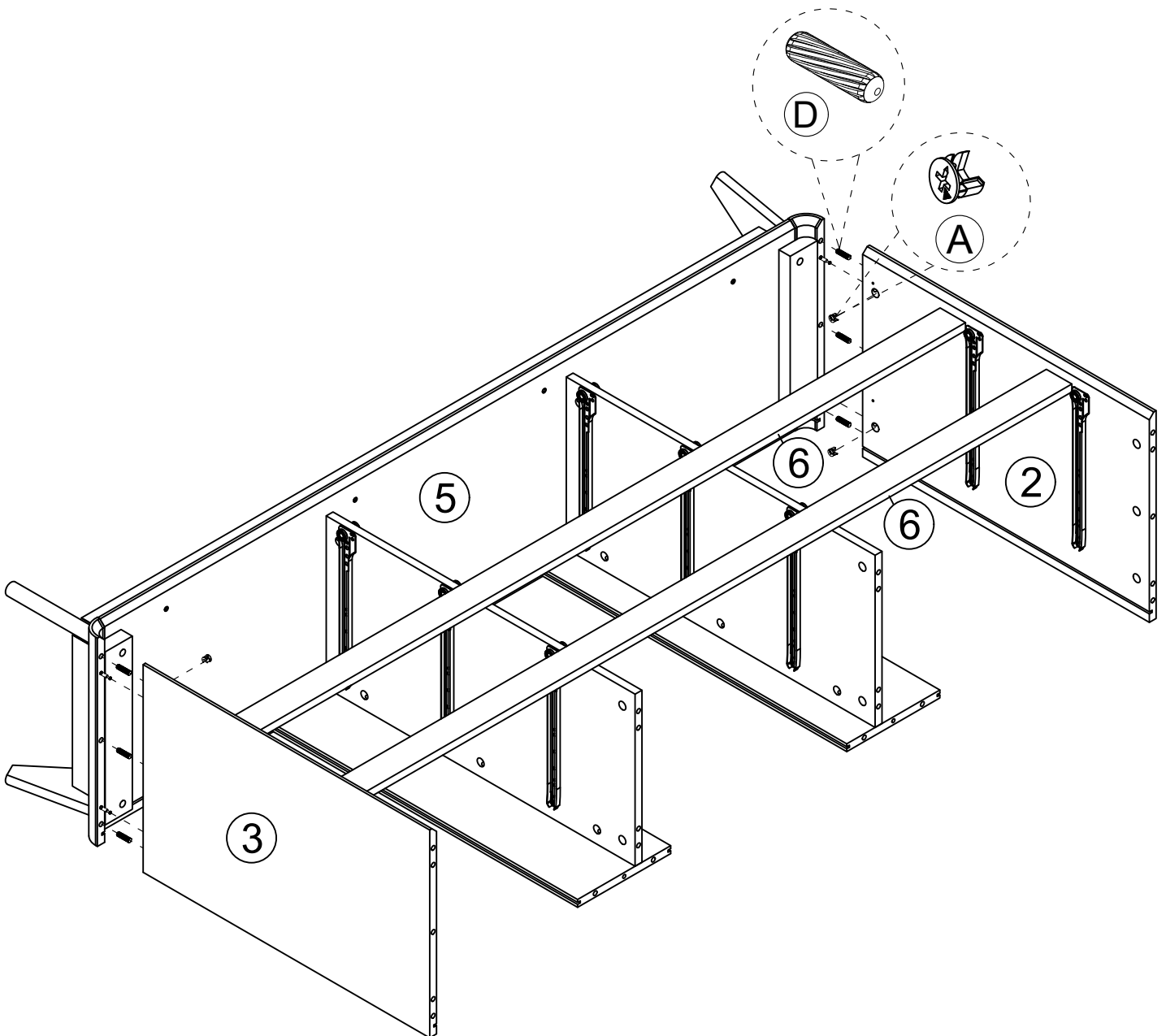
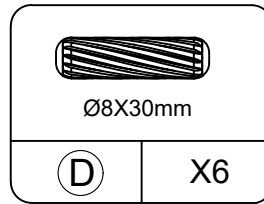
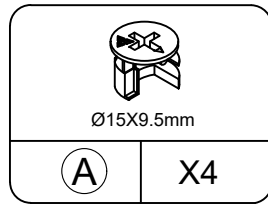
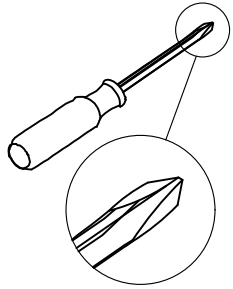

# STEP 19

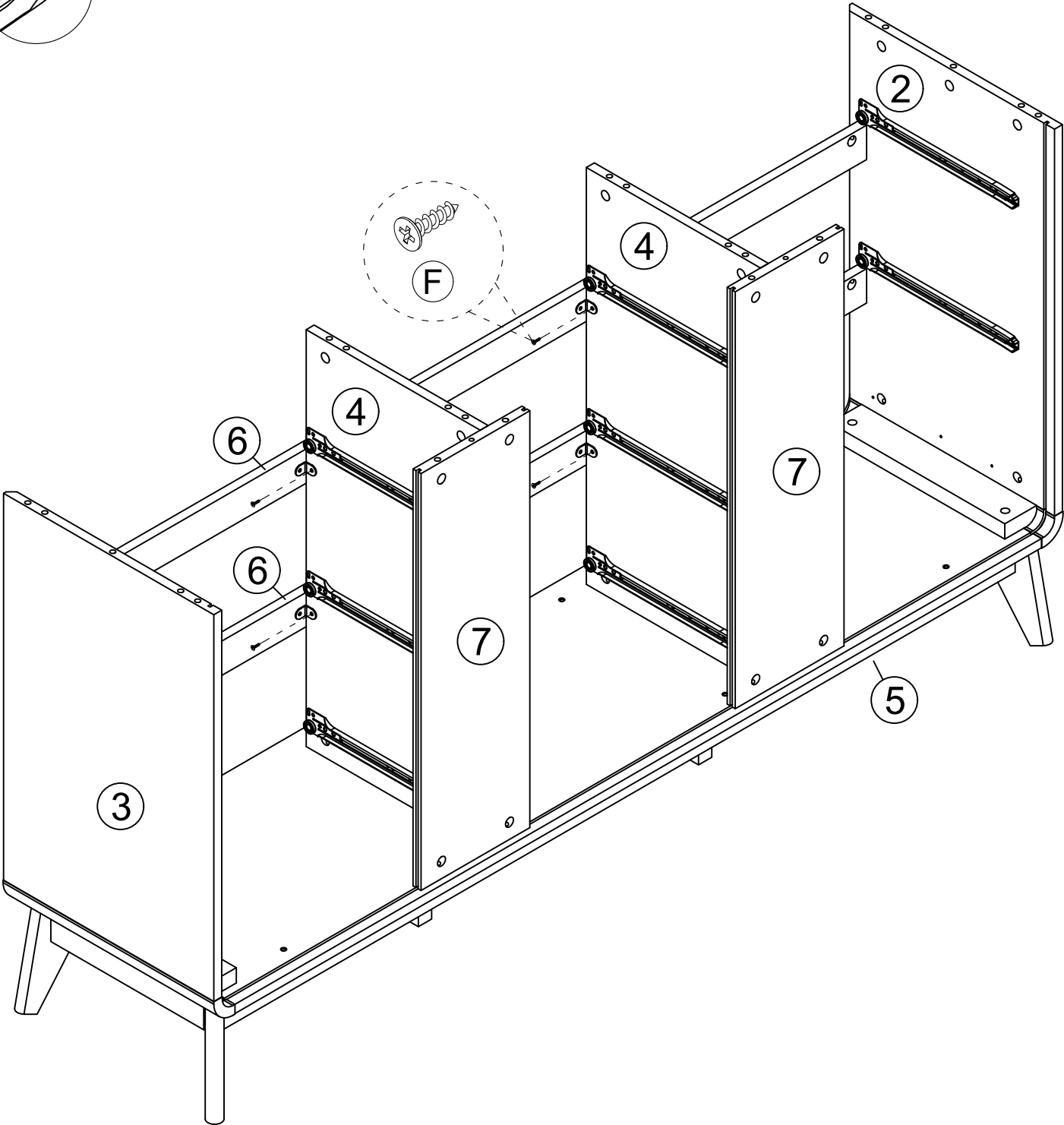
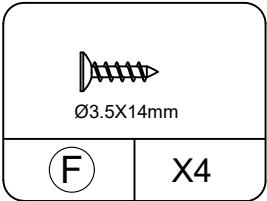
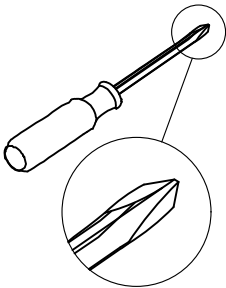

# STEP 20

---

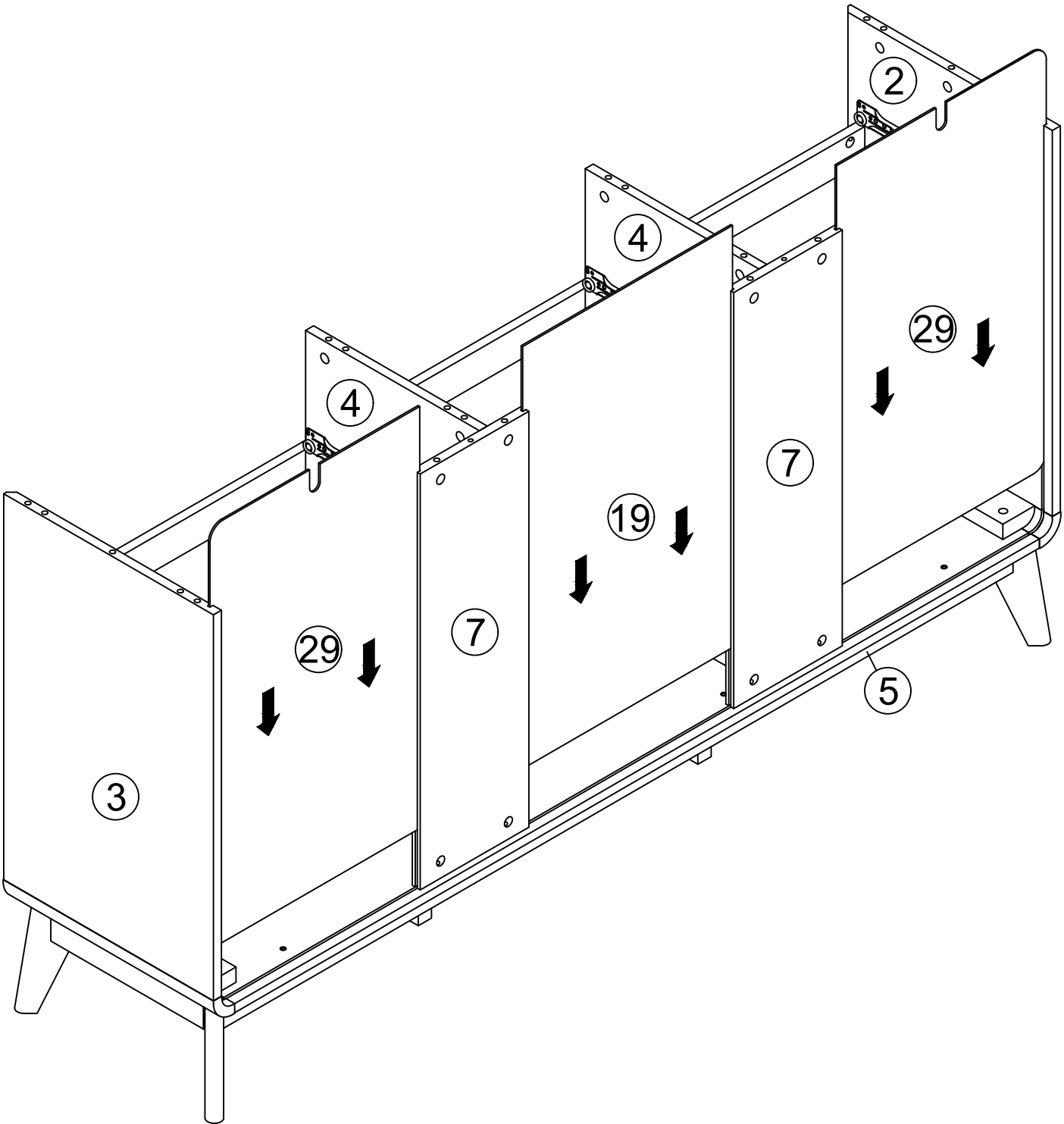

# STEP 21

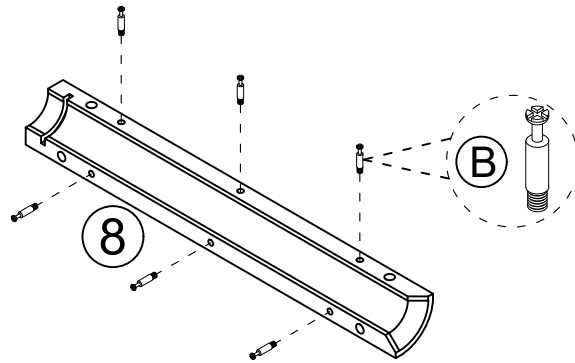
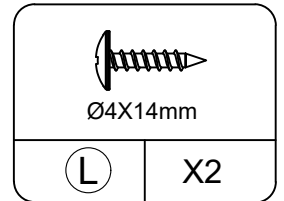
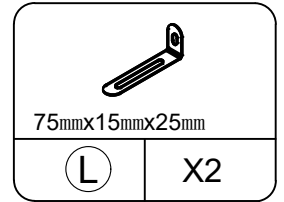
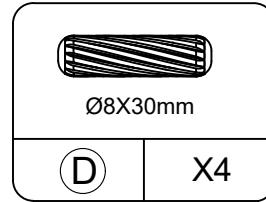
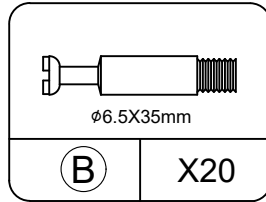
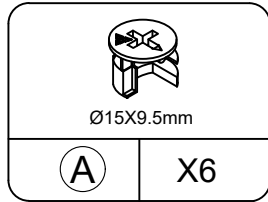
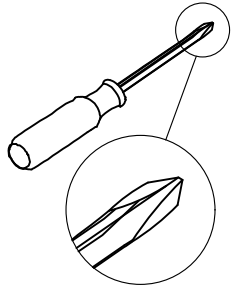

X 2

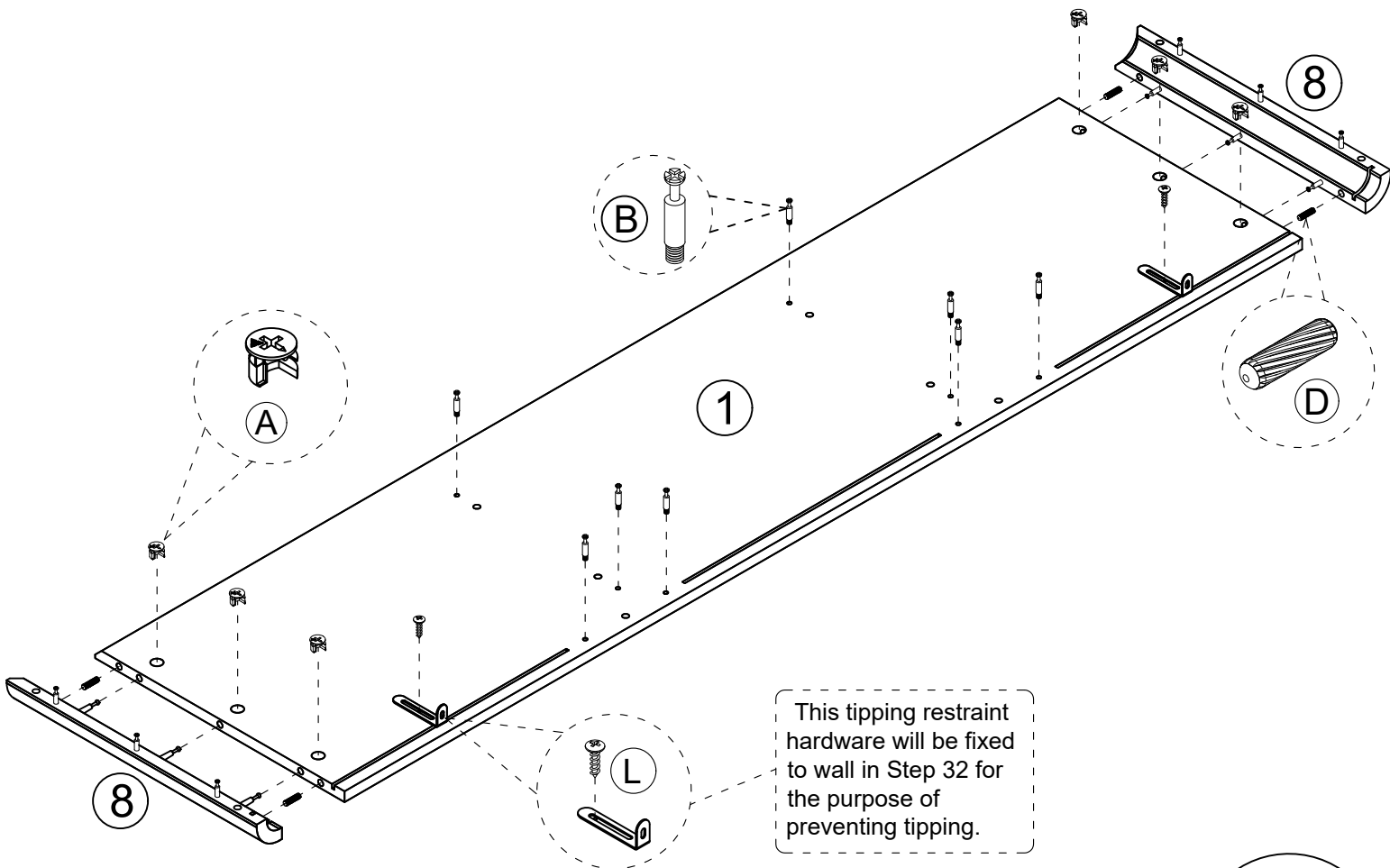

This tipping restraint hardware will be fixed to wall in Step 32 for the purpose of preventing tipping.

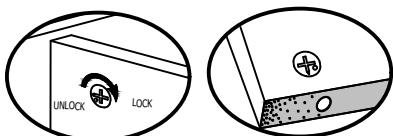

Proper orientation of CAM LOCK

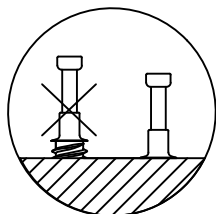

# STEP 22

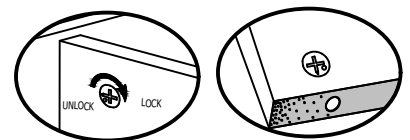
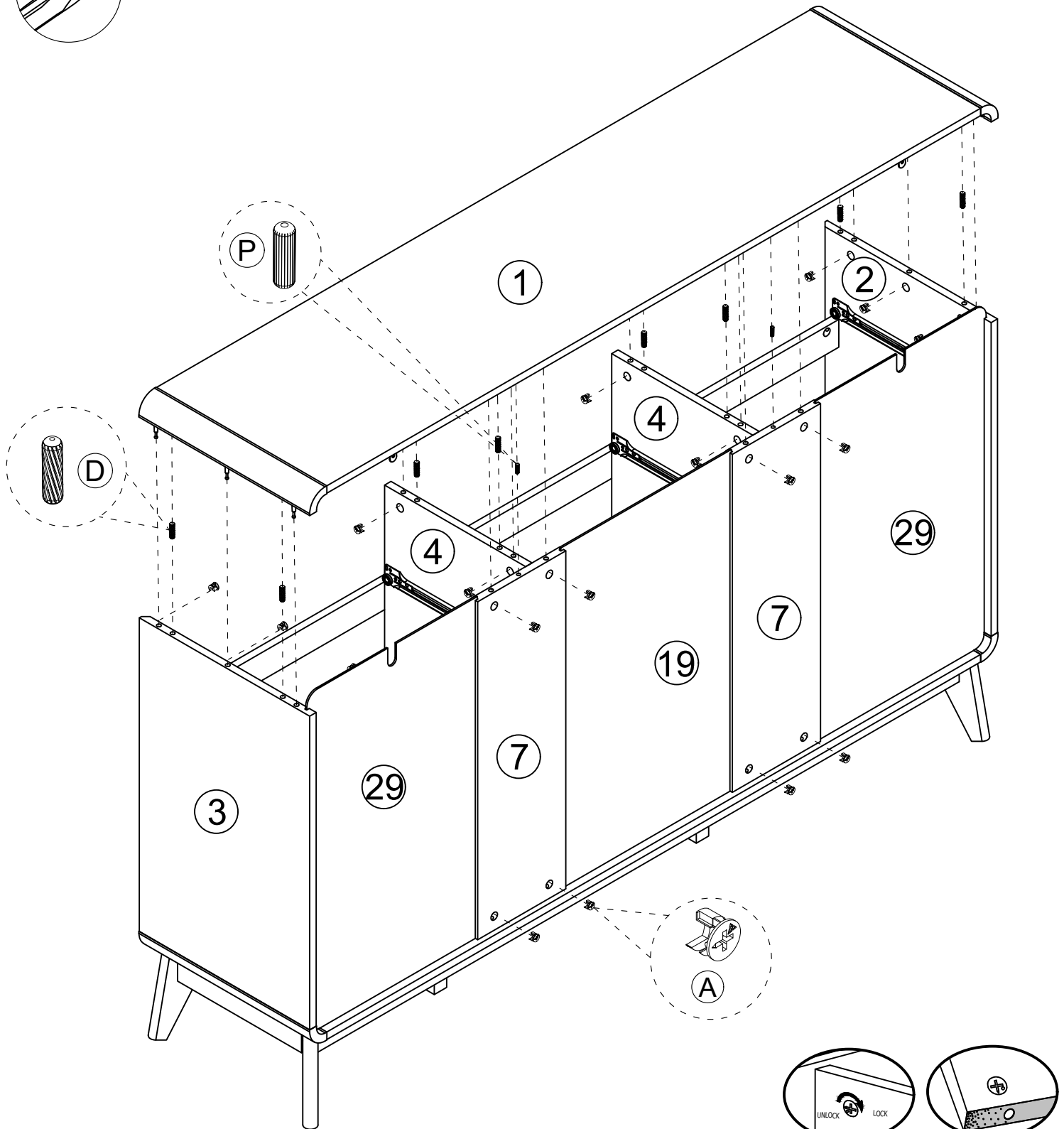
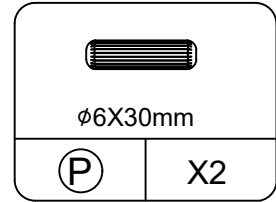
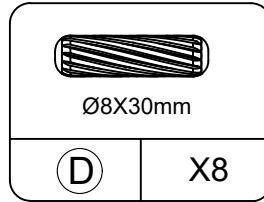
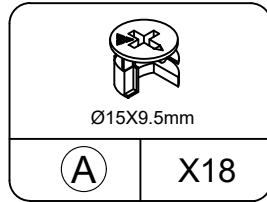
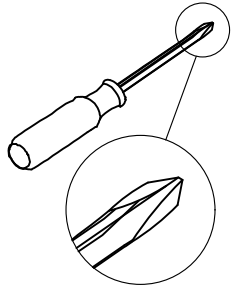

# STEP 23

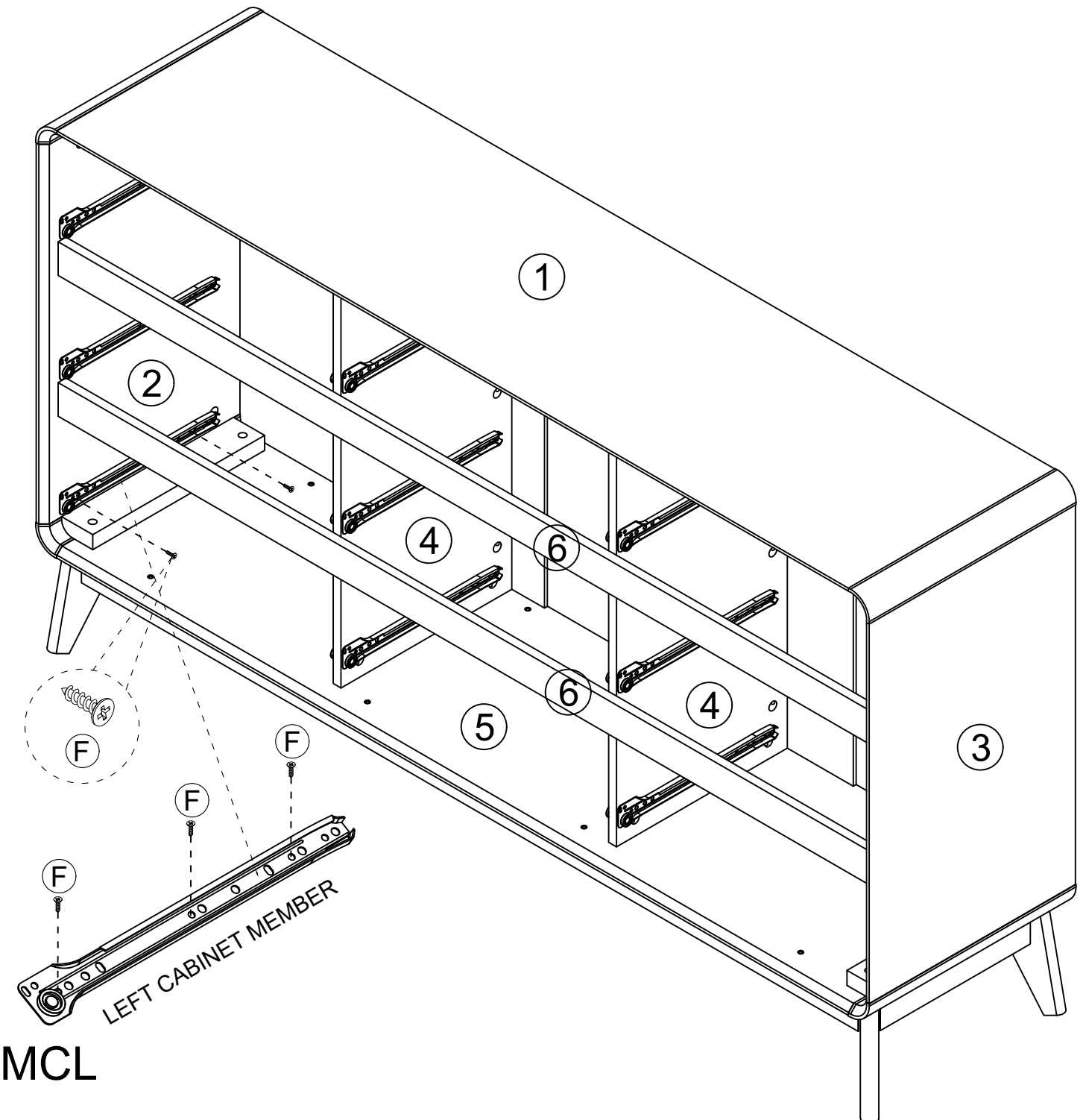
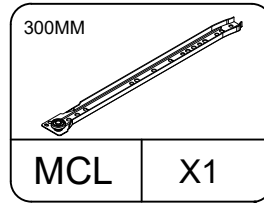
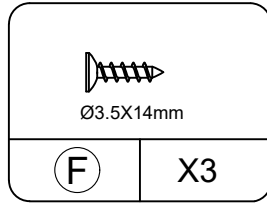
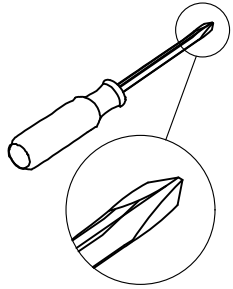

MCL

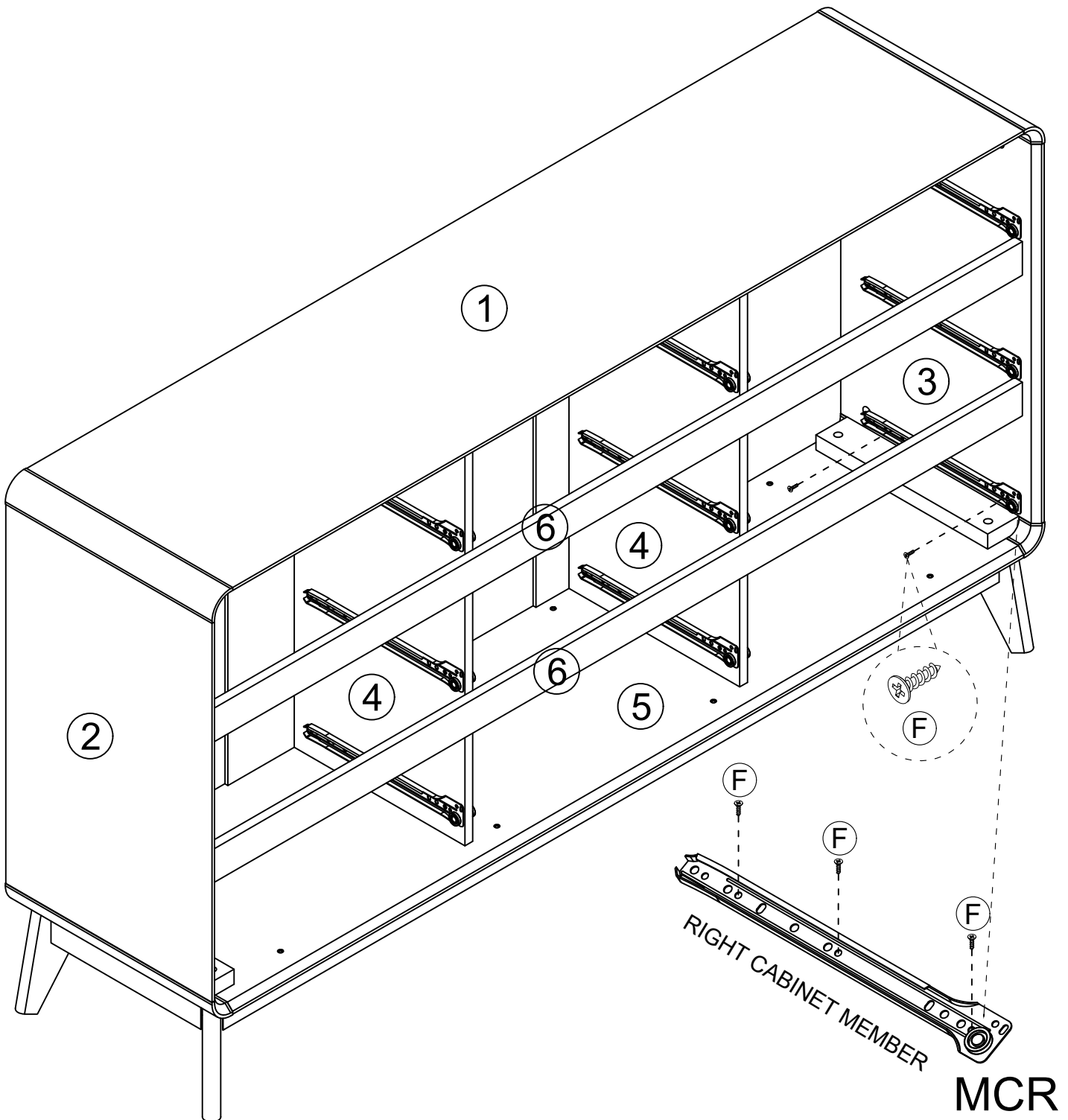
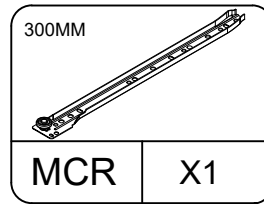
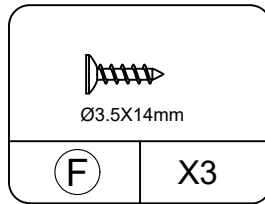
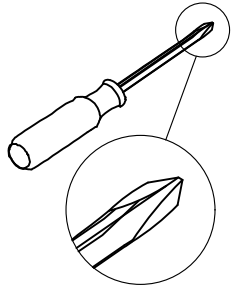

# STEP 24

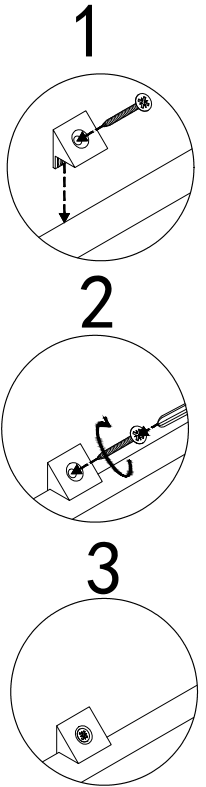
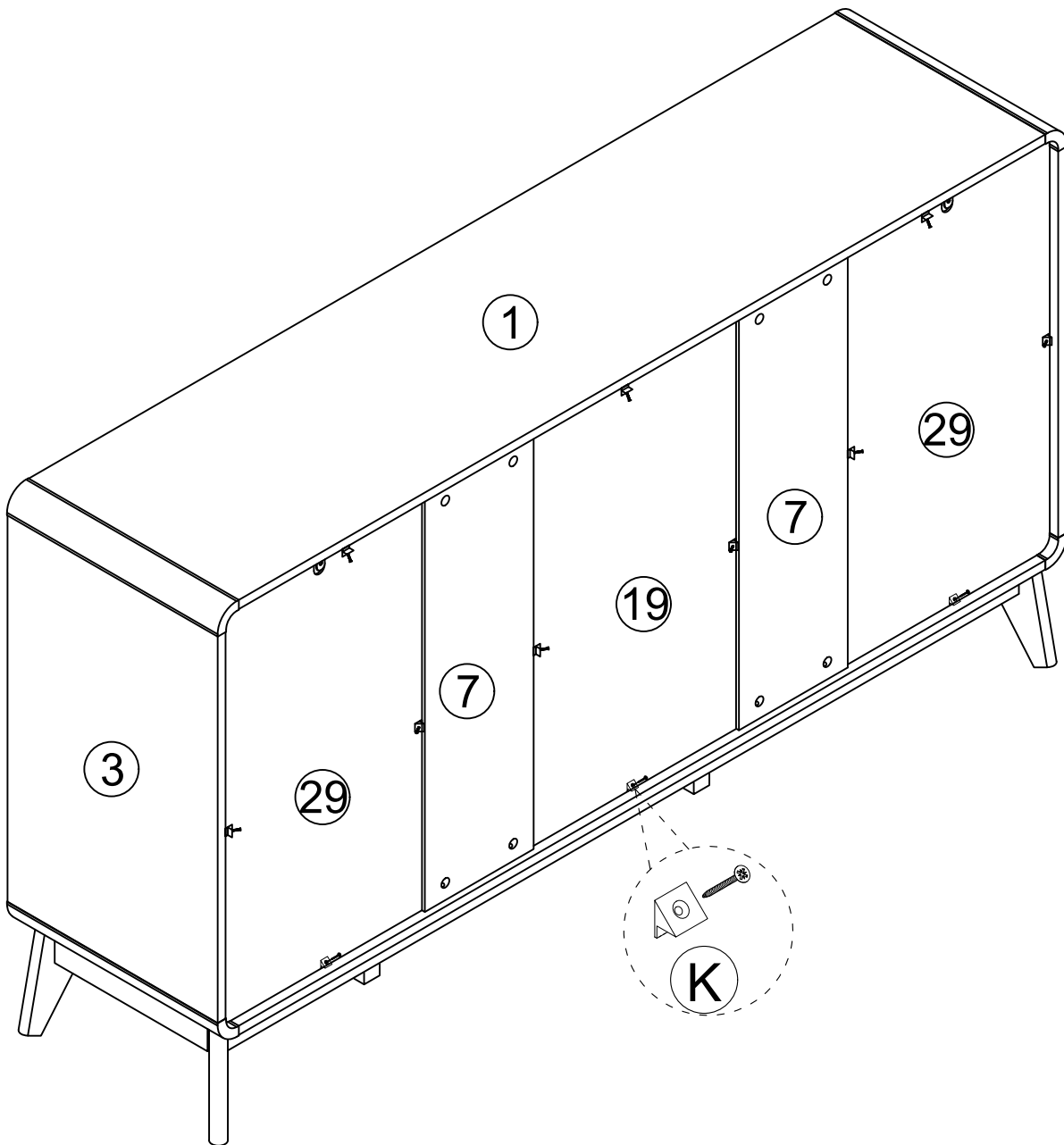
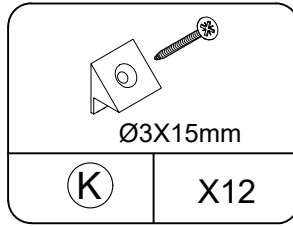
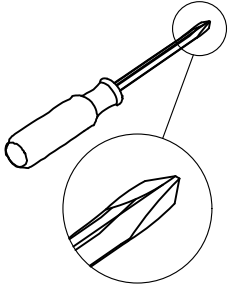

# STEP 25



# STEP 26

1PCS  Ø8X35mm	1PCS  Ø4X35mm
L	X2 set



**NOTE:**The tipping restraint hardware included is for wooden stud wall construction. It must be attached to a wall stud. Depending upon your wall construction different anchor hardware maybe required. Please contact your local hardware store for assistance. Young children can be seriously injured by tipping furniture. You must install the tipping restraint hardware with the unit to prevent the unit from tipping, causing any accidents or damage. The tipping restraints are intended only as a deterrent and are not a substitute for proper adult supervision. The tipping restraints are not earthquake restraints. If you wish to add the extra security of earthquake restraints, they must be purchased and installed separately.

We have included a set of tipping restraint hardware for this unit. You must install this hardware to prevent accidents or injuries that can result from the unit falling. When properly installed, this restraint can provide protection against the unexpected tipping of the unit due to small tremors, bumps or climbing. We strongly recommend mounting this hardware to a wall stud and your unit.

## Install the tipping restraint hardware

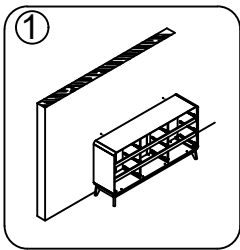

1. Push the cabinet close to the wall, make 2 marks on the wall through the holes in tipping restraint hardware;

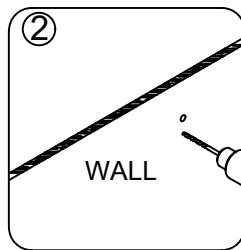

2. Move the cabinet away, and drill 2 6mm holes in the wall at the marked positions;

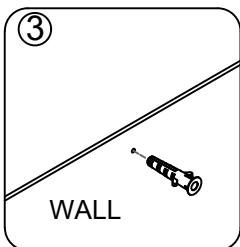

3. Insert 2 anchors into the holes;

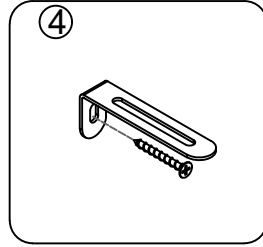

4. Push the cabinet close to the wall again, and fix the tipping restraint hardware to the wall with the long screws.

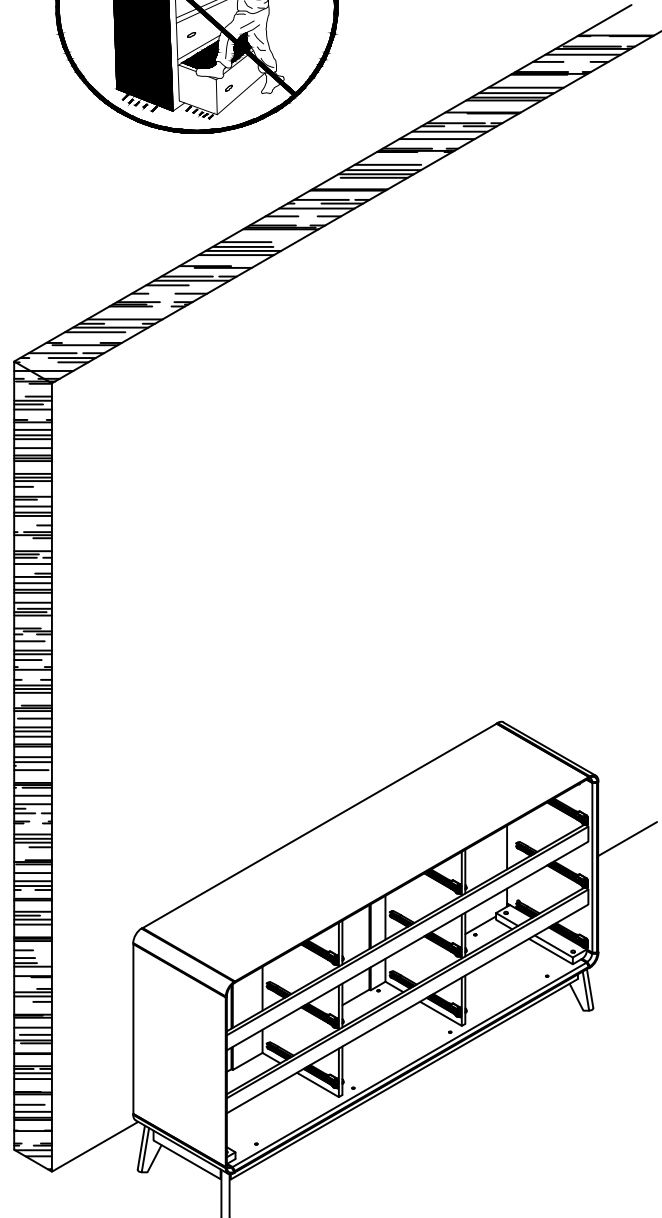

# STEP 27

Cabinet Slide

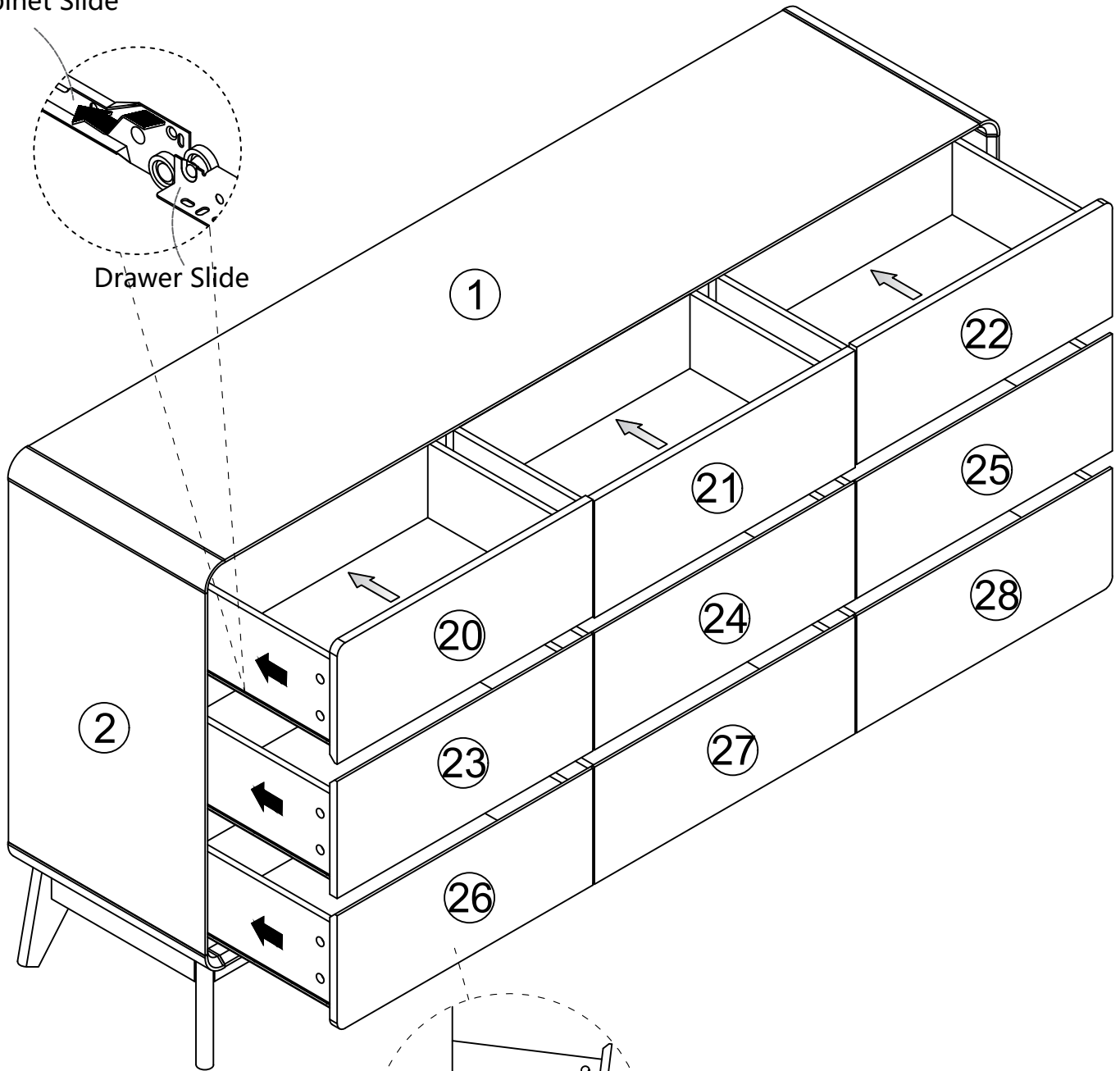

Drawer Slide

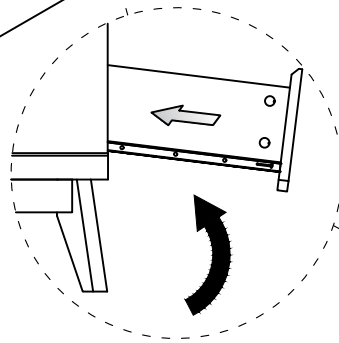

Install the drawer box at an angle as shown in the diagram

## ⚠ WARNING



Children have died from furniture tipover. To reduce the risk of furniture tipover:

- ALWAYS install tipover restraint provided.
- NEVER put a TV on this product.
- NEVER allow children to stand, climb or hang on drawers, doors, or shelves.
- NEVER open more than one drawer at a time.
- Place heaviest items in the lowest drawers.
- Do not defeat or remove the drawer interlock system.

This is a permanent label.

Do not remove!

## ⚠ ATTENTION



Des enfants sont morts du basculement des meubles. Pour réduire le risque de basculement des meubles:

- TOUJOURS installer la retenue de basculement fournie.
- NE JAMAIS mettre de téléviseur sur ce produit.
- NE JAMAIS permettre aux enfants de se tenir debout, de grimper ou de s'accrocher à des tiroirs, des portes ou des étagères.
- N'ouvrez JAMAIS plus d'un tiroir à la fois.
- Placez les objets les plus lourds dans les tiroirs les plus bas.
- Ne désactivez pas et ne retirez pas le système de verrouillage du tiroir.

Ceci est une étiquette permanente.

Ne pas enlever!

## ⚠ WARNUNG



Kinder sind an einem Möbelkipp gestorben. So verringern Sie das Risiko eines Umkippens von Möbeln:

- Installieren Sie IMMER die mitgelieferte Kipprückhaltevorrichtung.
- Stellen Sie NIEMALS einen Fernseher an dieses Produkt.
- Lassen Sie Kinder NIEMALS an Schubladen, Türen oder Regalen stehen klettern oder hängen.
- Öffnen Sie NIEMALS mehr als eine Schublade gleichzeitig.
- Legen Sie schwerste Gegenstände in die untersten Schubladen.
- Besiegen oder entfernen Sie das Schubladenverriegelungssystem nicht.

Dies ist ein dauerhaftes Etikett.

Nicht entfernen!