

ASSEMBLY INSTRUCTIONS & PARTS IDENTIFICATION

48" FOUR DOOR ACCENT CABINET



ASSEMBLY INSTRUCTIONS & PARTS IDENTIFICATION

Parts key

No	Code	Qty	Description	No	Code	Qty	Description
1		1 pc	Top	9	P07L	2 pcs	Left Side Facing End Door
2		1 pc	Bottom Shelf	10	P07R	2 pcs	Right Side Facing End Door
3		1 pc	Front Frame	11	P51H	6 pcs	Side Panel Hinge
4	P51L	1 pc	Left Side Facing Side Panel	12	P07H	12 pcs	Door Hinge
5	P51R	1 pc	Right Side Facing Side Panel	13	P02M	1 pc	Middle Leg
6	P08V	1 pc	Vertical Partition	14	P01L	5 pcs	Leveler
7	P08	2 pcs	Shelf	15	P01D	2 pcs	Door Catch
8		2 pcs	Back Panel	16	P01AT	1 set	Anti-Tip Kit
8A	P07T	4 pcs	Door Tab				

Hardware Kit

No	Code	Qty	Description	No	Code	Qty	Description
17	P08P	8 pcs	Shelf Pin	19	P01S	8 pcs	Wood Screw
18	P04	4 pcs	Knob w/ Screw	20	P01WD	2 pcs	Wood Dowel

PLEASE NOTE: Assembly requires two people. Follow directions step by step.

Step:01

Carefully lay out all pieces on a padded surface to prevent damage. Take extra care when removing the door unit from the carton. Doors must be secured so they will not fall open.

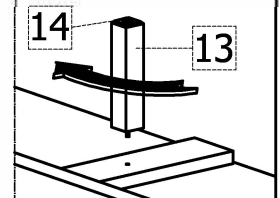
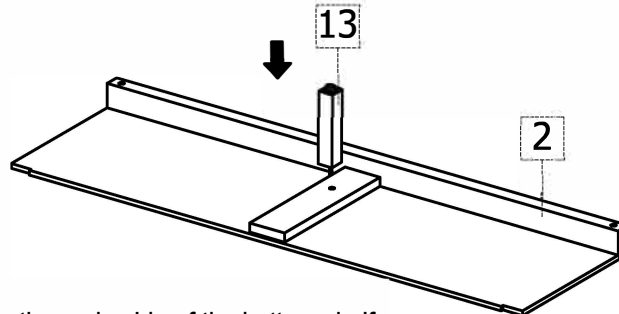

-Attach the middle support legs to the underside of the bottom shelf.

Step:02

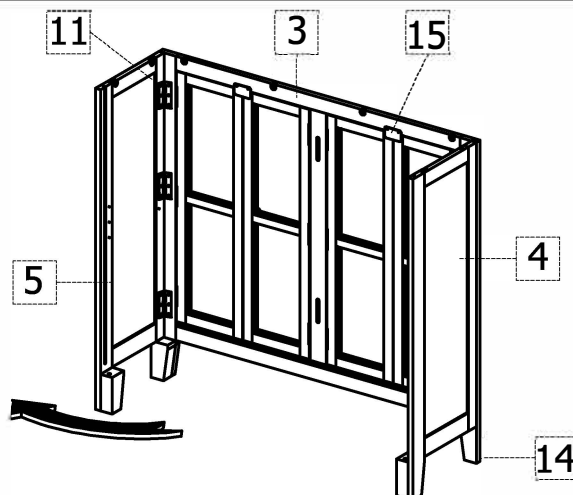

- With the help of the second person, open the front frame assembly positioning the two side panels of the cabinet 90° perpendicular to the cabinet frame.

ASSEMBLY INSTRUCTIONS & PARTS IDENTIFICATION

Step:03

- Insert the wood dowels into the rear leg support.

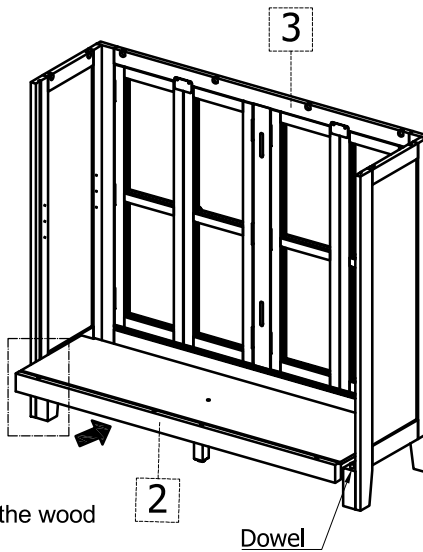
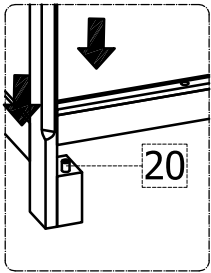

- Place the bottom shelf in position and lock into the wood dowels in the rear leg.

Step:04

-Insert the Vertical Partition by placing the tab on the panel into the receiver on the Front Frame and gently push down to lock into place. Make sure that the locking tab is in the opened position to insert into the bottom shelf.

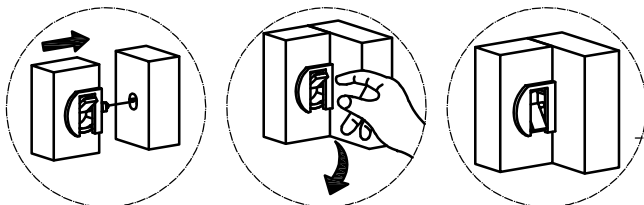

Tab in opened position Pull tab down to lock Tab in locked position

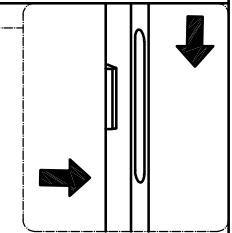
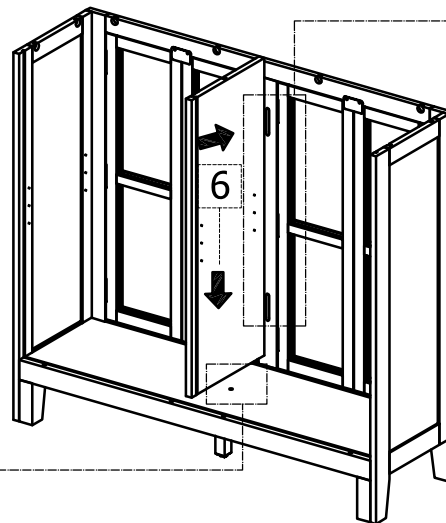

- Lock the tab (see diagram below) to secure the vertical panel to the bottom shelf

Step:05

- Carefully insert the back panels into place making sure that the lock tabs are in the open position on the bottom of the back panel.
- Once in place, lock the tabs on the bottom.

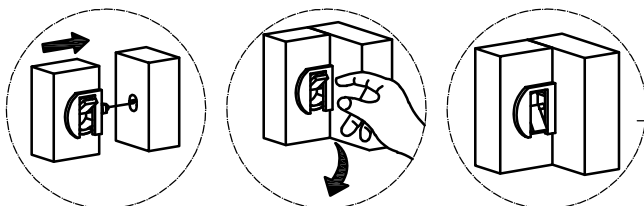

Tab in opened position Pull tab down to lock Tab in locked position

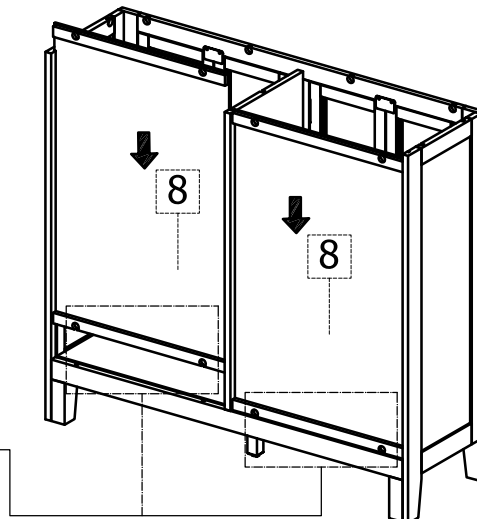

ASSEMBLY INSTRUCTIONS & PARTS IDENTIFICATION

Step:06

- Line up all the locking tabs in the open position
- With two people, carefully align the top in place making sure that the tab fits into the receiver portion on the top. Once firmly in place, lock the tabs.

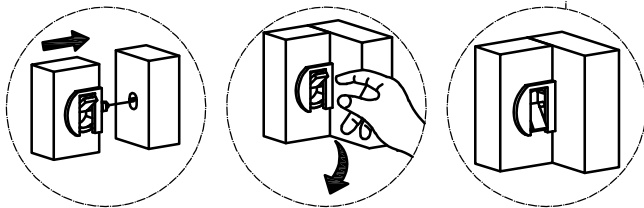

Tab in opened position Pull tab down to lock Tab in locked position

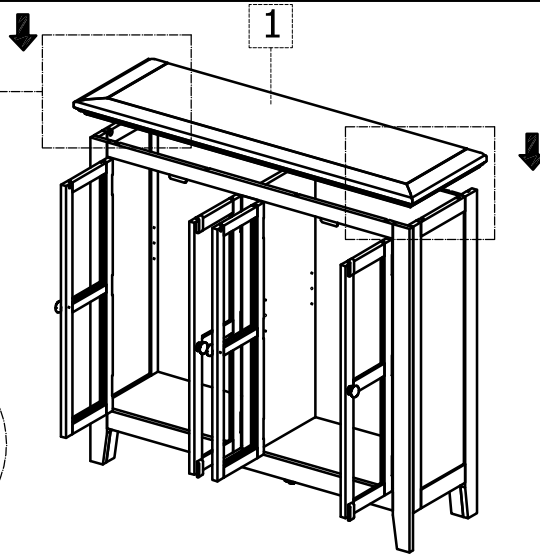

Step:07

- Install the shelves using the shelf pins. it is important to secure the shelf in place with the wood screws (See Diagram)
- Install the knobs as shown

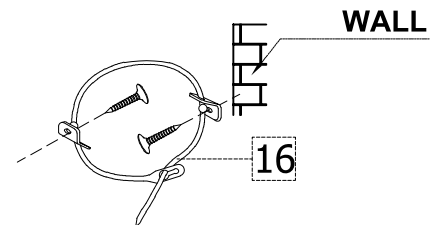
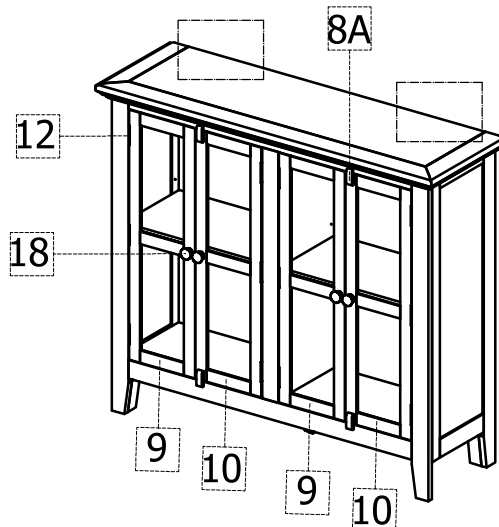
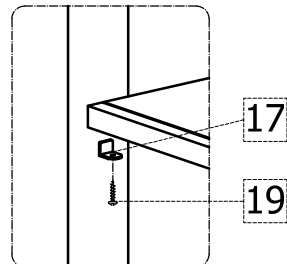
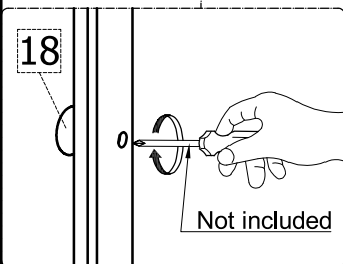
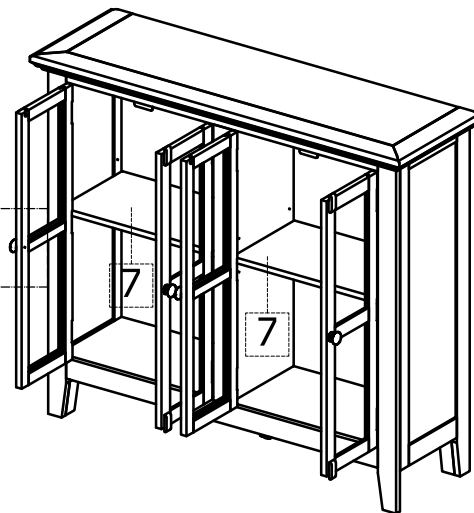

PLEASE NOTE :

To help prevent the possibility of tip-over, install the ANTI- TIP OVER restraint provided.