

# ASSEMBLY INSTRUCTION

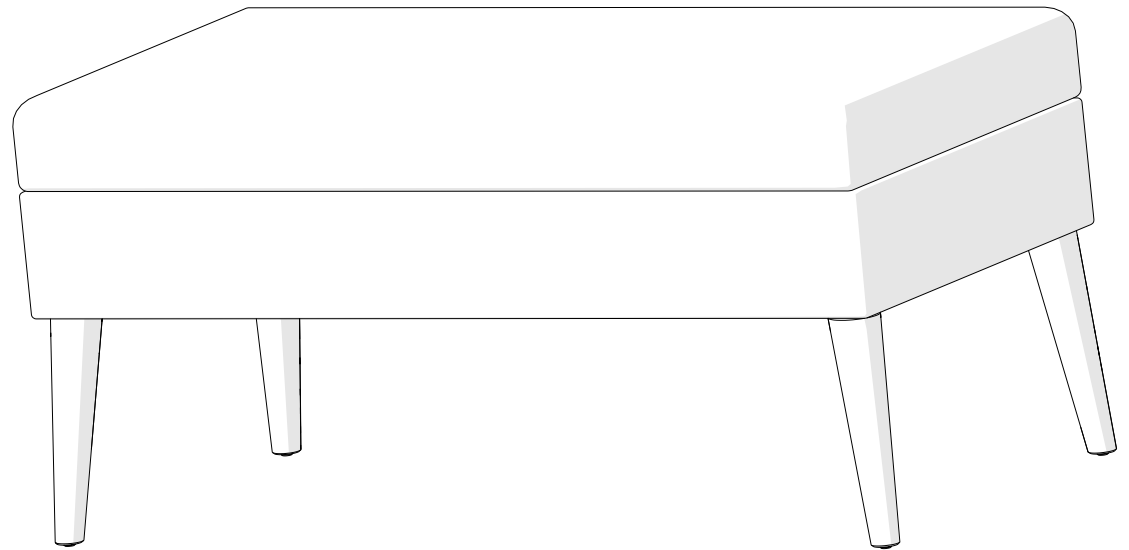

# table of contents



introduction	2
hardware	4
parts list	5
assembly	6

# hardware

---

(A) x 8

5/16" x 45mm  
round hex screw

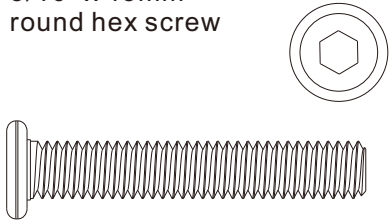

(B) x 8

Φ 8mm lock washer



(C) x 8

Φ 22mm flat washer

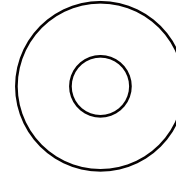

(D) x 1

5mm Ball end  
Hex wrench

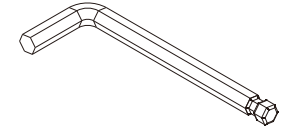

ITEM DESCRIPTION QUANTITY



①	box	1
②	leg	4

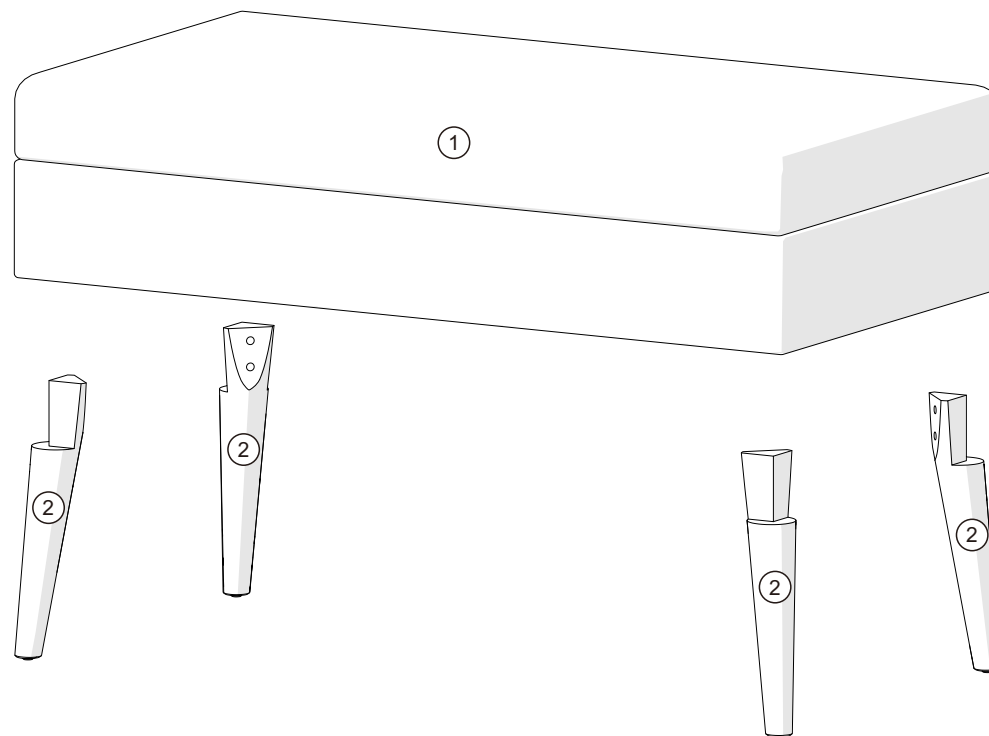

# step 1.

---

1

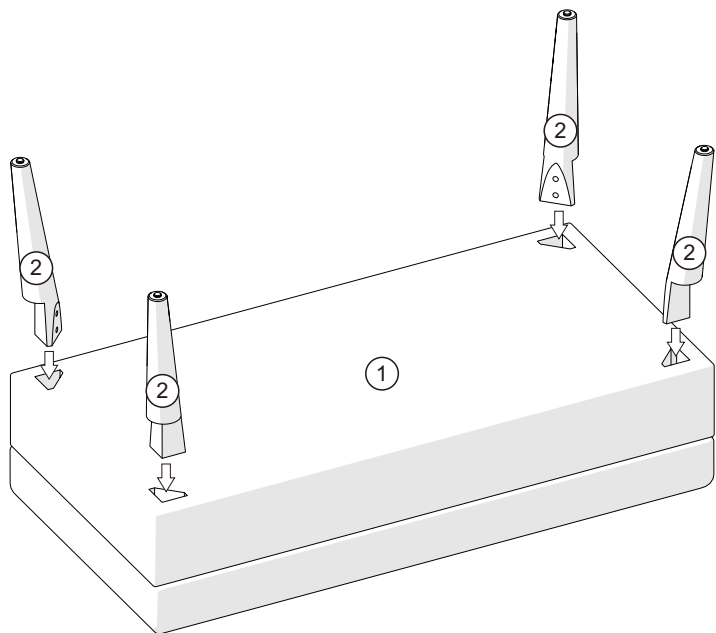

2

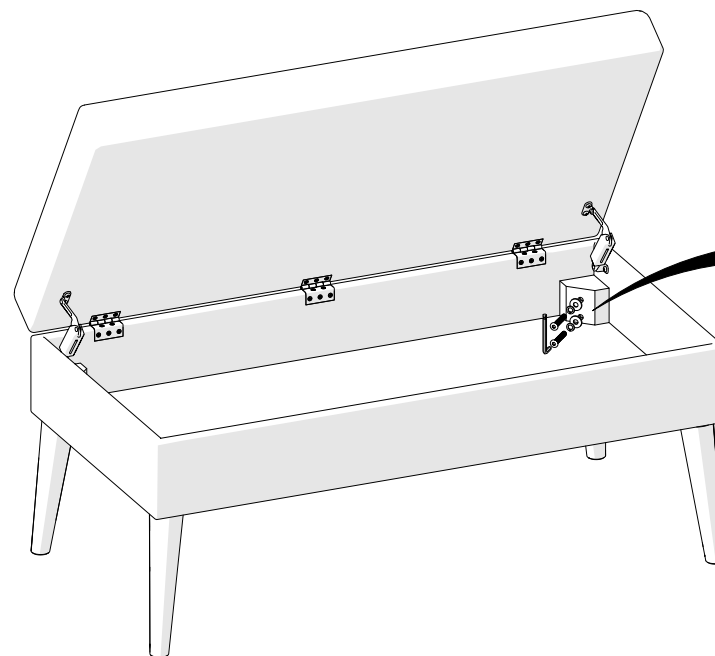

---

(A) x 8

5/16" x 45mm  
round hex screw

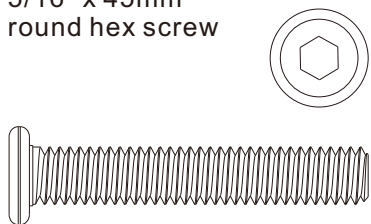

(B) x 8

Φ 8mm lock washer

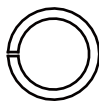

(C) x 8

Φ 22mm flat washer

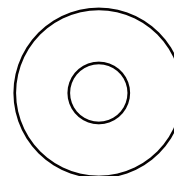

(D) x 1

5mm Ball end  
Hex wrench

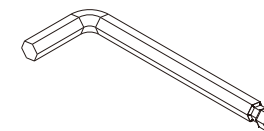

Please do not assemble with power tools