

# FH0072

## Assembly Instructions

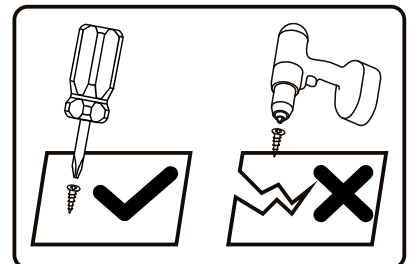
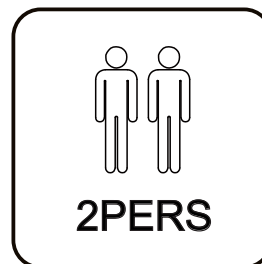
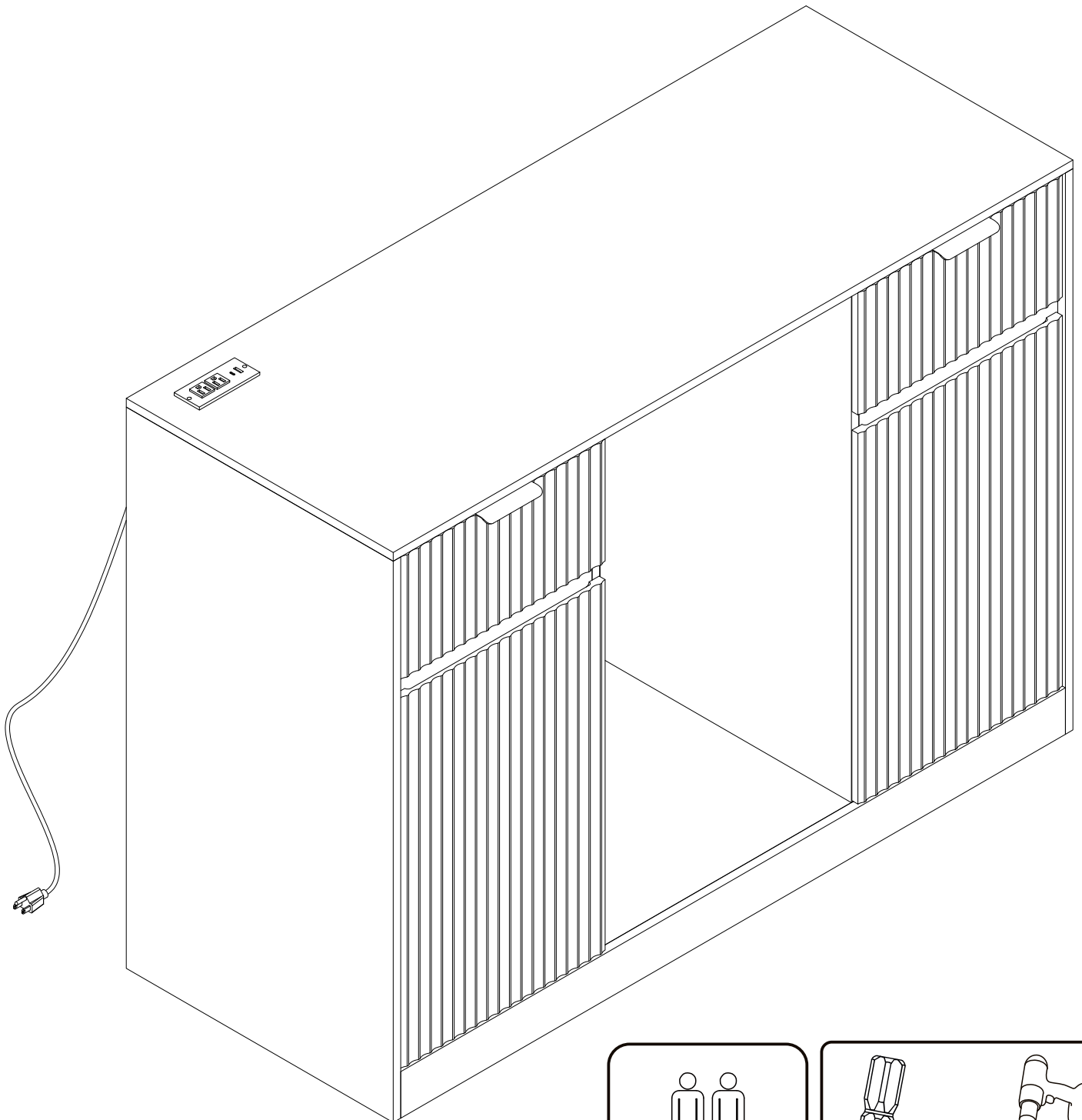

**Tools Recommended**

**EN**

Thank you for purchasing this product!  
Please read this manual carefully before starting assembly to ensure proper and safe use.

**DE**

Vielen Dank für den Kauf dieses Produkts!  
Bitte lesen Sie diese Anleitung sorgfältig durch, bevor Sie mit dem Aufbau beginnen,  
um eine korrekte und sichere Verwendung zu gewährleisten.

**ES**

¡Gracias por comprar este producto!  
Lea atentamente este manual antes de comenzar el montaje para garantizar un uso correcto y seguro.

**IT**

Grazie per aver acquistato questo prodotto!  
Si prega di leggere attentamente il manuale prima di iniziare il montaggio  
per garantire un uso corretto e sicuro.

**FR**

Merci d' avoir acheté ce produit!  
Veuillez lire attentivement ce manuel avant de  
commencer l' assemblage afin d' assurer une utilisation correcte et en toute sécurité.



**FR**

**Pensez à  
donner ou recycler.**



Association

ou



Magasin

ou



Déchèterie

<https://quefairedemesdechets.fr>

# IMPORTANT NOTICE

- This product contains small components, please ensure that they are kept away from small children.
- THIS INSTRUCTIONS CONTAINS IMPORTANT SAFETY INFORMATION. PLEASE READ BEFORE ASSEMBLY AND KEEP FOR FUTURE REFERENCE.
- Read each step carefully. It is very important that each step of instruction is performed in the correct order. If these steps are not followed in sequence, assembly difficulties will occur.
- Make sure all parts are included. Most parts are labelled or stamped on the raw edge.
- Work in spacious area, preferably on a carpet, near the place the unit will be used.
- Do not use power tools to assemble your furniture. Power tools may strip or damage the parts.
- Move your new furniture carefully, with two people lift and carry the unit to it's new location.
- Never push, drag or pull your furniture (especially on carpet)



## PLEASE DO NOT RETURN PRODUCT TO US IMMEDIATELY

If a part is missing or damaged, email our customer service. We will gladly ship your replacement parts FREE of charge.

Need Parts or Assistance? Email us : [cs@nbrehome.com](mailto:cs@nbrehome.com)

For Prompt, reliable service, please have your assemble instruction ready

## WARNING



**Children have died from furniture tipover. To reduce the risk of furniture tipover:**

- ALWAYS install anti-tip device provided.
- NEVER put a TV on this product.
- NEVER allow children to stand, climb or hang on any drawers, doors, or shelves.
- NEVER open more than one drawer at a time.
- Place heaviest items in the lowest drawers.



*This is a permanent label.  
Do not remove!*

# WICHTIGE HINWEISE

- Dieses Produkt enthält Kleinteile. Bitte außerhalb der Reichweite von kleinen Kindern aufbewahren.
- DIESE ANLEITUNG ENTHÄLT WICHTIGE SICHERHEITSHINWEISE.  
BITTE VOR DEM AUFBAU LESEN UND ZUR SPÄTEREN VERWENDUNG AUFBEWAHREN.
- Lesen Sie jeden Schritt sorgfältig. Es ist sehr wichtig, dass die Schritte in der richtigen Reihenfolge ausgeführt werden.  
Andernfalls kann es zu Schwierigkeiten beim Aufbau kommen.
- Stellen Sie sicher, dass alle Teile enthalten sind. Die meisten Teile sind gekennzeichnet oder an der Rohkante gestempelt.
- Arbeiten Sie in einem geräumigen Bereich, vorzugsweise auf einem Teppich in der Nähe des Aufstellortes.
- Verwenden Sie keine Elektrowerkzeuge für die Montage. Elektrowerkzeuge können Teile beschädigen oder überdrehen.
- Bewegen Sie das neue Möbelstück vorsichtig. Heben und tragen Sie es zu zweit an den neuen Standort.
- Schieben, ziehen oder zerran Sie das Möbelstück niemals (besonders nicht auf Teppichboden).



## BITTE SENDEN SIE DAS PRODUKT NICHT SOFORT ZURÜCK

Wenn ein Teil fehlt oder beschädigt ist, kontaktieren Sie bitte unseren Kundenservice. Wir senden Ihnen kostenlos Ersatzteile zu.

Benötigen Sie Hilfe oder Ersatzteile? Schreiben Sie an: [cs@nbrehome.com](mailto:cs@nbrehome.com)

Für einen schnellen und zuverlässigen Service halten Sie bitte Ihre Montageanleitung bereit.

## ! WARNUNG



**Kinder sind durch umkippende Möbel ums Leben gekommen. Um das Risiko eines Umkippens zu verringern:**

- IMMER die mitgelieferte Kippsicherung anbringen.
- NIEMALS einen Fernseher auf dieses Möbelstück stellen.
- NIEMALS Kinder auf Schubladen, Türen oder Regalen stehen, klettern oder hängen lassen.
- NIEMALS mehr als eine Schublade gleichzeitig öffnen.
- Schwere Gegenstände immer in die untersten Schubladen legen.

*Dies ist ein dauerhaftes Etikett.  
Nicht entfernen!*

# NOTES IMPORTANTES

- Ce produit contient de petites pièces. Veuillez les tenir hors de portée des jeunes enfants.
- CE MANUEL CONTIENT DES INFORMATIONS DE SÉCURITÉ IMPORTANTES. VEUILLEZ LIRE AVANT L' ASSEMBLAGE ET CONSERVER POUR RÉFÉRENCE FUTURE.
- Lisez attentivement chaque étape. Il est essentiel de suivre les instructions dans le bon ordre. Sinon, des difficultés d' assemblage peuvent survenir.
- Assurez-vous que toutes les pièces sont présentes. La plupart sont étiquetées ou marquées sur le bord brut.
- Travaillez dans un espace spacieux, de préférence sur un tapis près de l' endroit où le meuble sera utilisé.
- N' utilisez pas d' outils électriques pour l' assemblage. Ils peuvent endommager ou détériorer les pièces.
- Déplacez les meubles avec précaution. Soulevez-les à deux et transportez-les à l' endroit désiré.
- Ne poussez, ne tirez ou ne faites jamais glisser le meuble (surtout sur un tapis).



## VEUILLEZ NE PAS RETOURNER LE PRODUIT IMMÉDIATEMENT

Si une pièce est manquante ou endommagée, veuillez contacter notre service client. Nous vous enverrons gratuitement les pièces de rechange.

Besoin d'aide ou de pièces? Écrivez-nous à: [cs@nbrehome.com](mailto:cs@nbrehome.com)

Pour un service rapide et fiable, veuillez avoir votre manuel de montage à portée de main.



## AVERTISSEMENT



**Des enfants sont morts à cause du basculement de meubles.**

**Pour réduire le risque de basculement:**

- TOUJOURS installer le dispositif anti-basculement fourni.
- NE PLACEZ JAMAIS de télévision sur ce meuble.
- NE LAISSEZ JAMAIS les enfants grimper ou se suspendre aux tiroirs, portes ou étagères.
- NE JAMAIS ouvrir plus d' un tiroir à la fois.
- Placer les objets les plus lourds dans les tiroirs du bas.



*Étiquette permanente.  
Ne pas retirer!*

# NOTE IMPORTANTI

- Questo prodotto contiene piccoli componenti. Tenerli lontani dalla portata dei bambini.
- QUESTO MANUALE CONTIENE INFORMAZIONI IMPORTANTI SULLA SICUREZZA. SI PREGA DI LEGGERE PRIMA DEL MONTAGGIO E CONSERVARE PER FUTURI RIFERIMENTI.
- Leggere attentamente ogni passaggio. È importante seguire l'ordine corretto delle istruzioni. Un ordine errato può causare difficoltà durante il montaggio.
- Verificare che tutte le parti siano incluse. La maggior parte dei pezzi è etichettata o timbrata sul bordo grezzo.
- Lavorare in un'area spaziosa, preferibilmente su un tappeto vicino alla zona d'uso.
- Non utilizzare utensili elettrici per il montaggio. Potrebbero danneggiare o spanare i componenti.
- Spostare i mobili con attenzione. Sollevarli e trasportarli in due persone fino alla nuova posizione.
- Non spingere, trascinare o tirare i mobili (soprattutto su tappeti).



## SI PREGA DI NON RESTITUIRE SUBITO IL PRODOTTO

Se manca un pezzo o è danneggiato, contatta il nostro servizio clienti. Saremo lieti di inviarti gratuitamente i pezzi di ricambio.

Hai bisogno di assistenza o pezzi di ricambio? Scrivici a: [cs@nbrehome.com](mailto:cs@nbrehome.com)

Per un'assistenza rapida ed efficiente, tieni a portata di mano le istruzioni di montaggio.



## AVVERTENZA



**Alcuni bambini sono morti a causa del ribaltamento di mobili.**

**Per ridurre il rischio di ribaltamento:**

- **INSTALLARE SEMPRE** il dispositivo anti-ribaltamento fornito.
- **NON POSIZIONARE MAI** una TV su questo mobile.
- **NON CONSENTIRE MAI** ai bambini di salire, arrampicarsi o appendersi a cassetti, ante o ripiani.
- **NON APRIRE MAI** più di un cassetto alla volta.
- Posizionare gli oggetti più pesanti nei cassetti inferiori.

*Etichetta permanente.*

*Non rimuovere!*

# NOTAS IMPORTANTES

- Este producto contiene piezas pequeñas. Manténgalas fuera del alcance de los niños pequeños.
- ESTE MANUAL CONTIENE INFORMACIÓN DE SEGURIDAD IMPORTANTE. LEA ANTES DE COMENZAR EL MONTAJE Y GUARDE PARA REFERENCIA FUTURA.
- Lea atentamente cada paso. Es muy importante seguir las instrucciones en el orden correcto. Si no se siguen en secuencia, el montaje puede resultar complicado.
- Asegúrese de que todas las piezas estén incluidas. La mayoría de las piezas están etiquetadas o marcadas en el borde.
- Trabaje en un área amplia, preferiblemente sobre una alfombra, cerca del lugar donde se usará el mueble.
- No utilice herramientas eléctricas para el montaje. Pueden dañar o desgastar las piezas.
- Mueva los muebles con cuidado. Levante y transporte la unidad entre dos personas a su nueva ubicación.
- Nunca empuje, arrastre ni tire de los muebles (especialmente sobre alfombra).

## **POR FAVOR, NO DEVUELVA EL PRODUCTO INMEDIATAMENTE**



Si falta alguna pieza o está dañada, comuníquese con nuestro servicio de atención al cliente. Con gusto le enviaremos gratis las piezas de repuesto.

¿Necesita ayuda o piezas de repuesto? Envíenos un correo a: [cs@nbrehome.com](mailto:cs@nbrehome.com)

Para recibir asistencia rápida y confiable, tenga a mano su manual de montaje.



## **ADVERTENCIA**



**Han muerto niños por el vuelco de muebles.**

**Para reducir el riesgo de vuelco:**

- SIEMPRE instale el dispositivo antivuelco incluido.
- NUNCA coloque un televisor sobre este mueble.
- NUNCA permita que los niños se suban, escalen o cuelguen de los cajones, puertas o estantes.
- NUNCA abra más de un cajón a la vez.
- Coloque los objetos más pesados en los cajones inferiores.

*Etiqueta permanente.  
¡No la quite!*



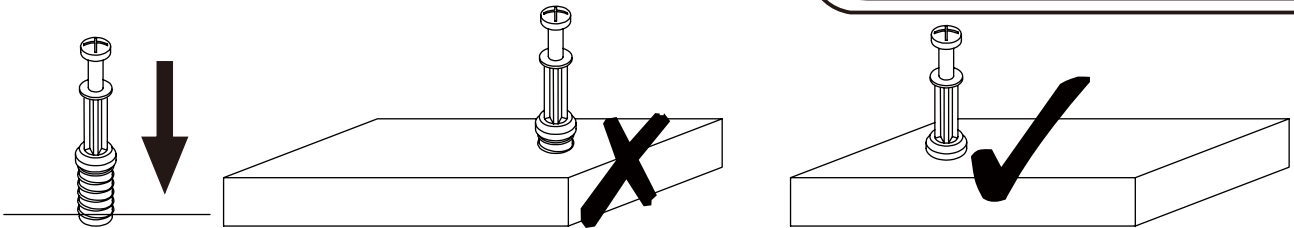

**EN\_QUICKFIT:** Tighten quickfit until shoulder is flush with panel. Do not overtighten or undertighten.

**FR\_RACCORD RAPIDE:** Faites serrer le raccord rapide jusqu'à ce que l'épaulement soit parfaitement encastré dans le panneau. Il ne faut ni trop serrer ni insuffisamment serrer.

**ES\_QUICKFIT:** Apriete quickfit hasta que el hombro se descargue con el panel. NO lo sobreapriete ni lo apriete poco.

**DE\_QUICKFIT:** Ziehen Sie den Quickfit fest, bis die Schulter mit der Platte bündig ist. Bitte nicht zu fest oder zu schwach anziehen.

**IT\_MONTAGGIO RAPIDO:** Stringere il montaggio rapido fino a quando la spalla è a filo con il pannello, non stringere troppo o troppo poco.

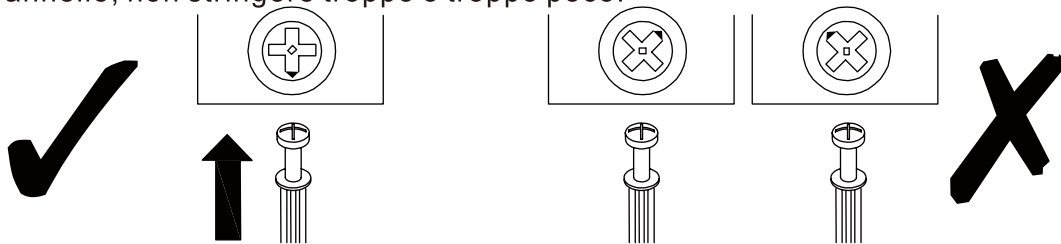

**EN\_CAM LOCK:** When fitting cam lock, ensure starting position is correct before you insert connecting quickfit.

**FR\_SERRURE BATTEUSE:** Avant d'insérer la serrure batteuse, veillez à la bonne orientation avant d'insérer le raccord rapide.

**ES\_CIERRE DE LA CÁMARA:** Cuando instale el cierre de la cámara, asegúrese de que la posición de inicio es correcta antes de que inserte el quickfit conector.

**DE\_CAM-LOCK:** Achten Sie bei der Montage des Cam-Locks auf die richtige Ausgangsposition, bevor Sie den Quickfit einsetzen.

**IT\_BLOCCAGGIO A CAMMA:** Quando si monta il bloccaggio a camma, assicurarsi che la posizione iniziale sia corretta prima di inserire il montaggio rapido di collegamento.

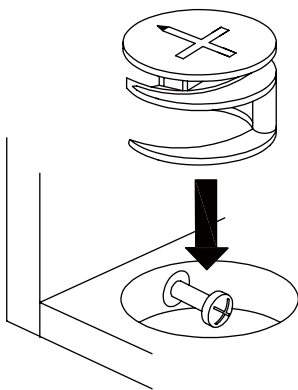

**EN\_Quickfit head** should be in the centre of the cam lock when the two panels are joined.

Cam lock should be inserted before quickfit.

**FR\_**Lorsque les deux panneaux sont assemblés, la tête du raccord rapide doit reposer au centre de la serrure batteuse. Il faut insérer la serrure batteuse avant le raccord rapide.

**ES\_**El cabezal del quickfit debe estar en el centro del cierre de la cámara cuando se unan los dos paneles.

Se debe insertar el cierre de la cámara antes que el quickfit.

**DE\_**Der Quickfit-Kopf sollte sich in der Mitte des Cam-Locks befinden, wenn die beiden Platten zusammengefügt sind. Der Cam-Lock sollte vor dem Quickfit eingesetzt werden.

**IT\_**La testa del montaggio rapido deve trovarsi al centro del bloccaggio a camma quando i due pannelli sono uniti.

Il Bloccaggio a Camma deve essere inserito prima del montaggio rapido.

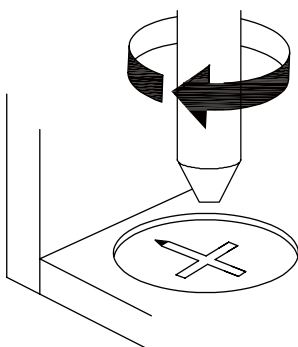

**EN\_**Turn cam lock clockwise to tighten.

**FR\_**Faites tourner la serrure batteuse dans le sens des aiguilles d'une montre pour la resserrer.

**ES\_**Gire el cierre de la cámara en sentido horario para apretarlo.

**DE\_**Drehen Sie den Cam-Lock im Uhrzeigersinn, um ihn festzuziehen.

**IT\_**Ruotare il bloccaggio a camma in senso orario per stringere.

**EN** It may be necessary to adjust the hinges so that the doors align. Use the instructions below as a guide.

**FR** Il est parfois nécessaire d'ajuster les charnières pour un meilleur alignement des portes. Servez-vous des instructions ci-dessous comme guide.

**ES** Puede que sea necesario ajustar los quicios de forma que se alineen las puertas. Use las instrucciones que aparecen debajo como guía.

**PT** Pode ser necessário ajustar as dobradiças para que as portas fiquem alinhadas. Utilizar as instruções abaixo como guia.

**DE** Möglicherweise müssen Sie die Scharniere so einstellen, dass die Türen ausgerichtet sind. Verwenden Sie die nachstehenden Anweisungen als Leitfaden.

**IT** Potrebbe essere necessario regolare le cerniere in modo che le porte siano allineate. Per fare ciò attenersi alle istruzioni sottostanti.

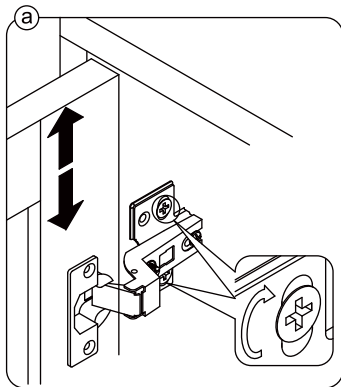

**EN** To adjust the door vertically loosen the screw as shown and move up and down as needed.

**FR** Si vous souhaitez régler la porte **verticalement**, desserrez la vis comme indiqué et déplacez la porte de haut en bas selon les besoins.

**ES** Para ajustar la puerta **verticalmente** afloje el tornillo tal y como se muestra y muévalo hacia arriba o hacia abajo según sea necesario.

**PT** Para ajustar a porta na vertical, soltar o parafuso mostrado e mover-se para cima e para baixo, conforme necessário.

**DE** Um die Tür **vertikal** auszurichten, lösen Sie die Schraube wie abgebildet und bewegen Sie sie nach Bedarf nach oben oder nach unten.

**IT** Per allineare la porta **verticalmente** allentare la vite come mostrato e spostarla in alto o in basso secondo necessità.

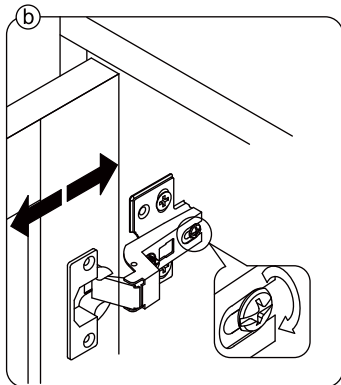

**EN** To adjust the gap from the door to the main frame turn the screw clockwise or anti-clockwise as needed.

**FR** Si vous souhaitez ajuster l'**écart** entre la porte et le cadre principal, tournez la vis dans le sens des aiguilles d'une montre ou dans le sens inverse, si nécessaire.

**ES** Para ajustar el **espacio** desde la puerta al marco principal, gire el tornillo en sentido horario o antihorario, según se necesite.

**PT** Para ajustar o espaço entre a porta e o quadro principal, rode o parafuso no sentido dos ponteiros do relógio ou anti-horário, conforme necessário.

**DE** Um den **Abstand** von der Tür zum Hauptrahmen auszurichten, drehen Sie die Schraube je nach Bedarf im oder gegen den Uhrzeigersinn.

**IT** Per regolare lo **spazio** tra la porta e il telaio principale, avvitare o svitare la vite secondo necessità.

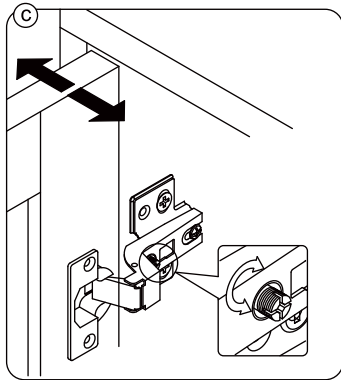

**EN** To adjust the door laterally adjust the screw as shown by turning clockwise or anti-clockwise.

**FR** Si vous souhaitez ajuster la porte **latéralement**, ajustez la vis comme indiqué en tournant dans le sens des aiguilles d'une montre ou dans le sens inverse des aiguilles d'une montre.

**ES** Para ajustar la puerta **lateralmente** ajuste el tornillo tal y como se muestra girándolo en sentido horario y antihorario.

**PT** Para ajustar a porta lateralmente ajustar o parafuso, conforme indicado, rodando no sentido dos ponteiros do relógio ou no sentido anti-horário.

**DE** Um die Tür **seitlich** auszurichten, stellen Sie bitte die Schraube wie abgebildet durch Drehen im oder gegen den Uhrzeigersinn ein.

**IT** Per allineare la porta **lateralmente** regolare la vite come mostrato, avvitandola o svitandola.

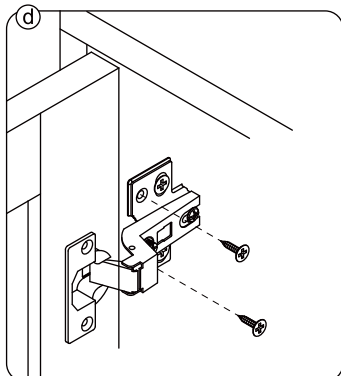

**EN** Please fix other screws

**FR** Merci de serrer les autres vis.

**ES** Fije los demás tornillos

**PT** Por favor fixe os outros parafusos

**DE** Befestigen Sie bitte die anderen Schrauben

**IT** Fissare le altre viti

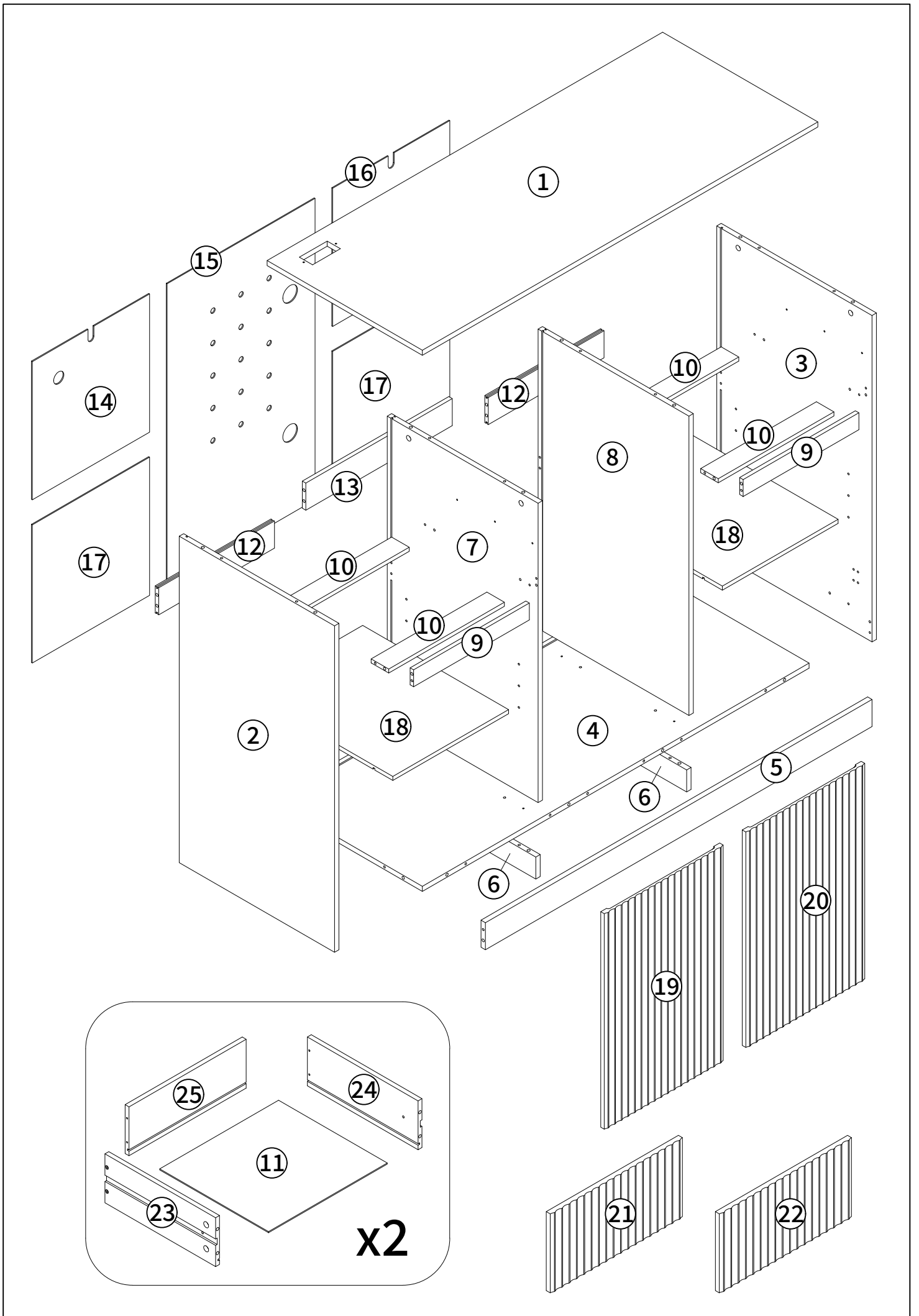

# BOX 1/2

# FH0072

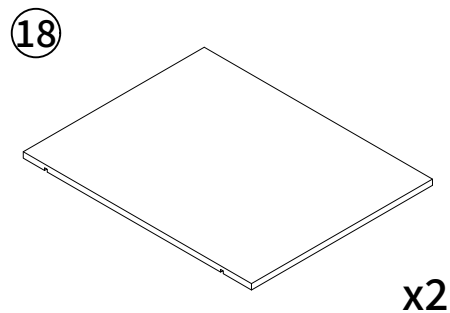
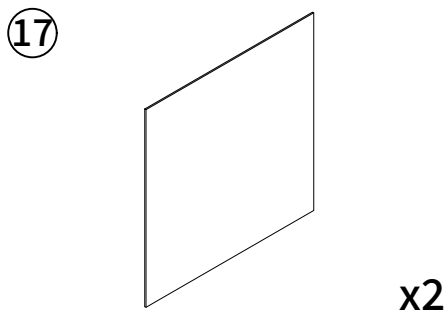
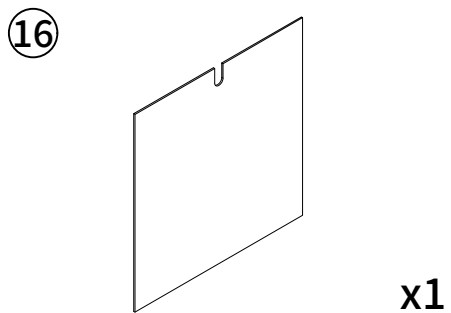
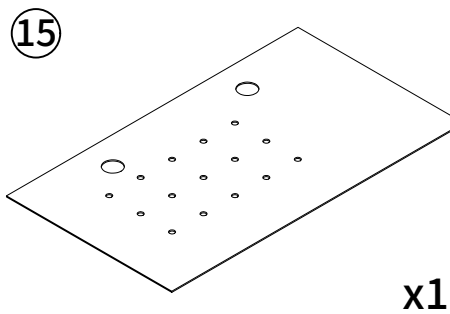
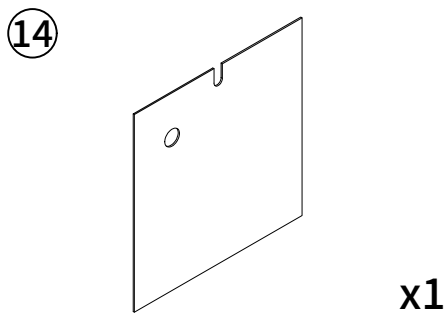
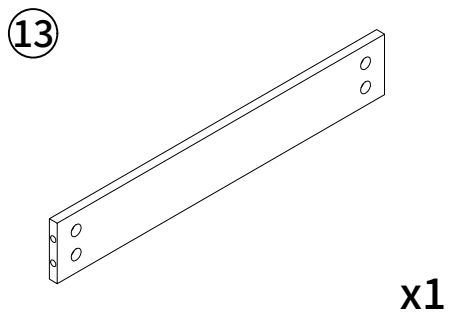
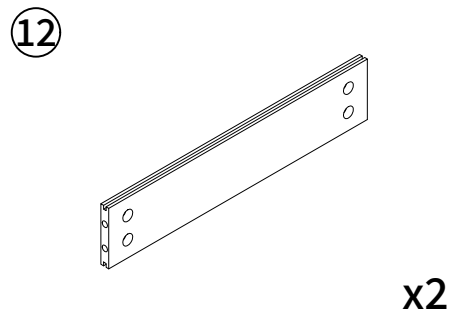
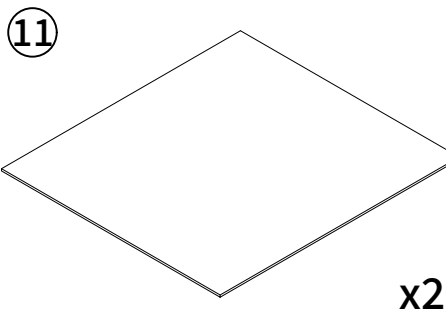
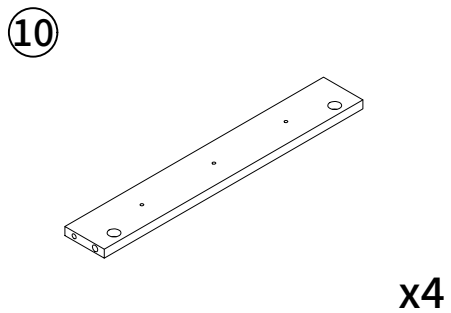
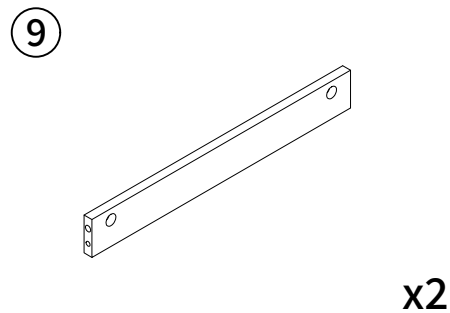
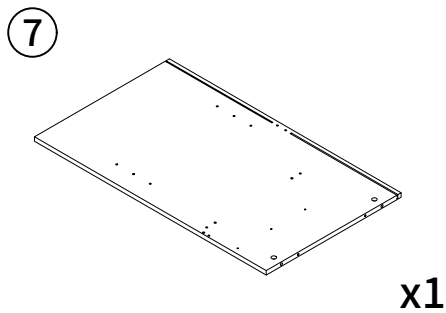
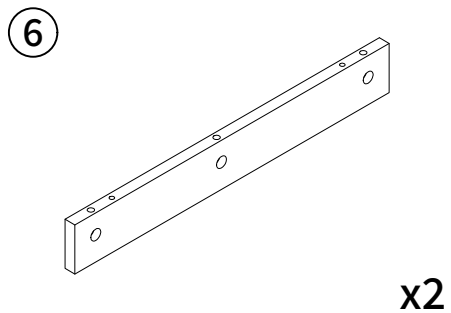
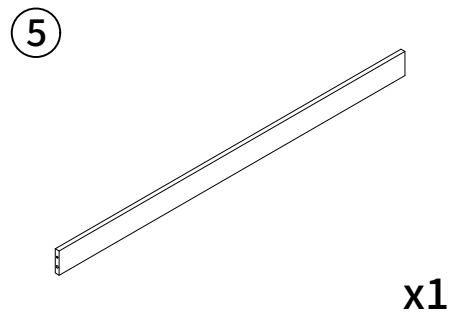
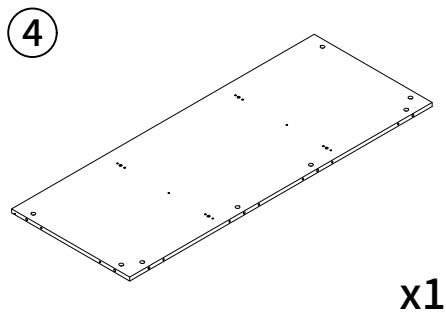
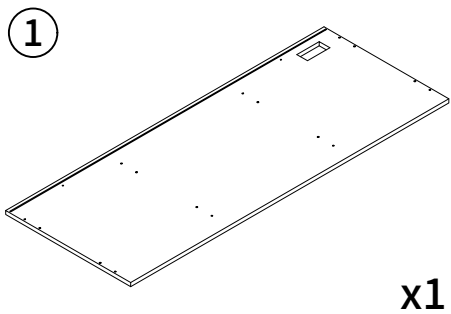

# BOX 1/2

# FH0072

19

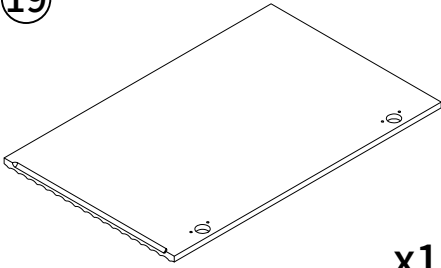

x1

20

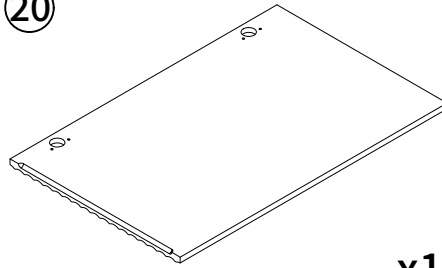

x1

21

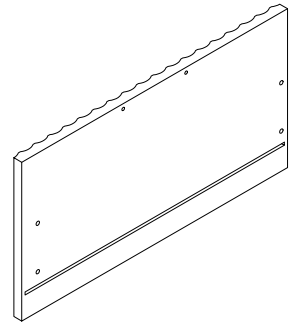

x1

22

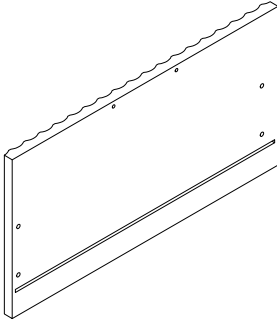

x1

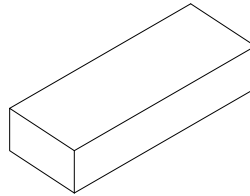

**HARDWARE PACK**

# BOX 2/2

# FH0072

②

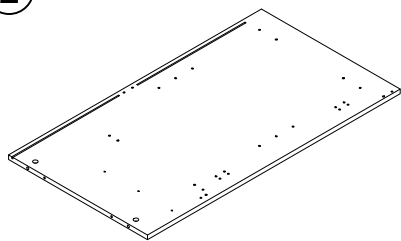

x1

③

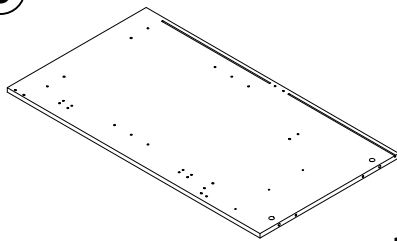

x1

⑧

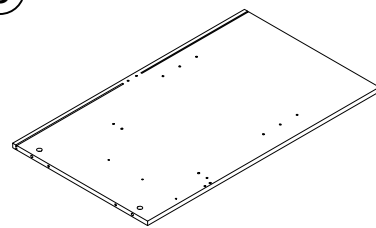

x1

⑳

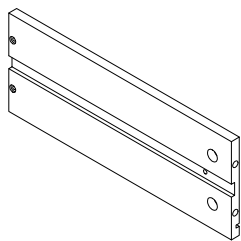

x2

㉑

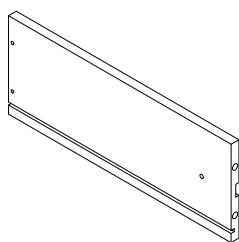

x2

㉒

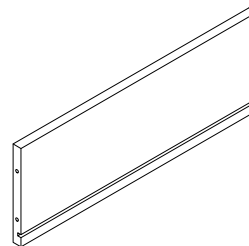

x2

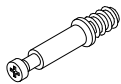

**A x 56**  
M6x35mm



**B x 56**  
M15x10mm

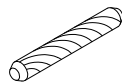

**C x 40**  
M6x30mm

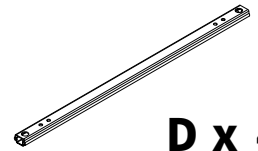

**D x 4**  
L 342mm



**E x 16**  
M3x12mm

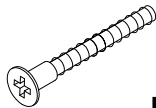

**F x 4**  
M5x40mm

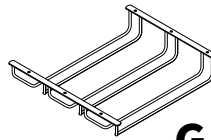

**G x 2**



**H x 36**  
M4x14mm

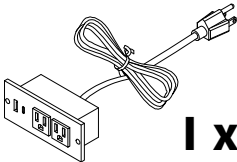

**I x 1**



**J x 2**  
M3.5x12mm



**K x 8**

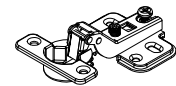

**L x 4**

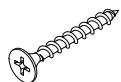

**M x 8**  
M4x30mm

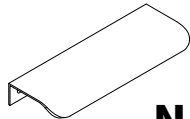

**N x 2**



**O x 24**



**P x 24**  
M3x16mm



**Q x 4**  
M4x10mm



**R x 2**  
M4x12mm

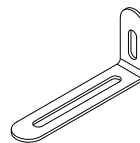

**S x 2**

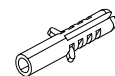

**T x 2**

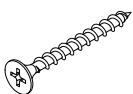

**U x 2**  
M4x35mm

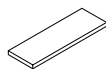

**V x 8**

01

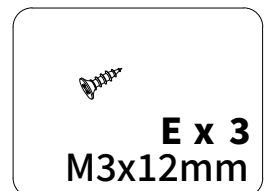
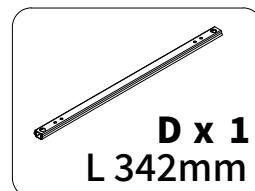
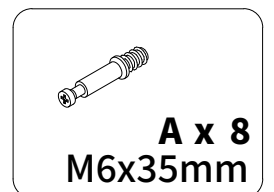
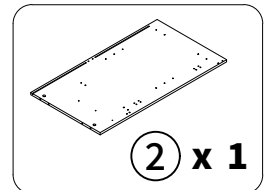
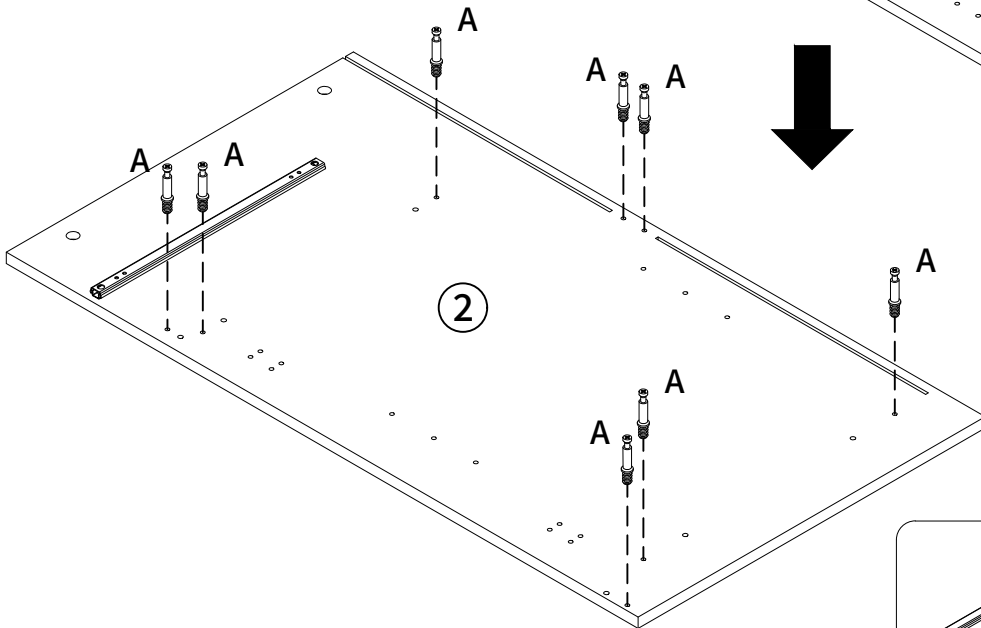
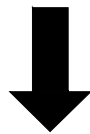
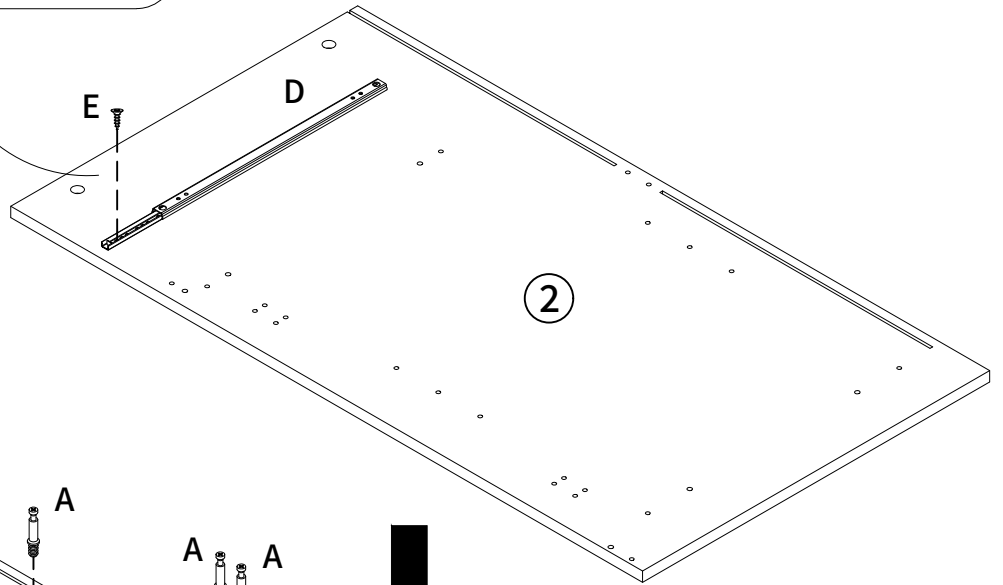
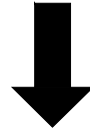
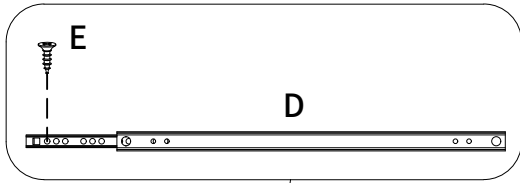
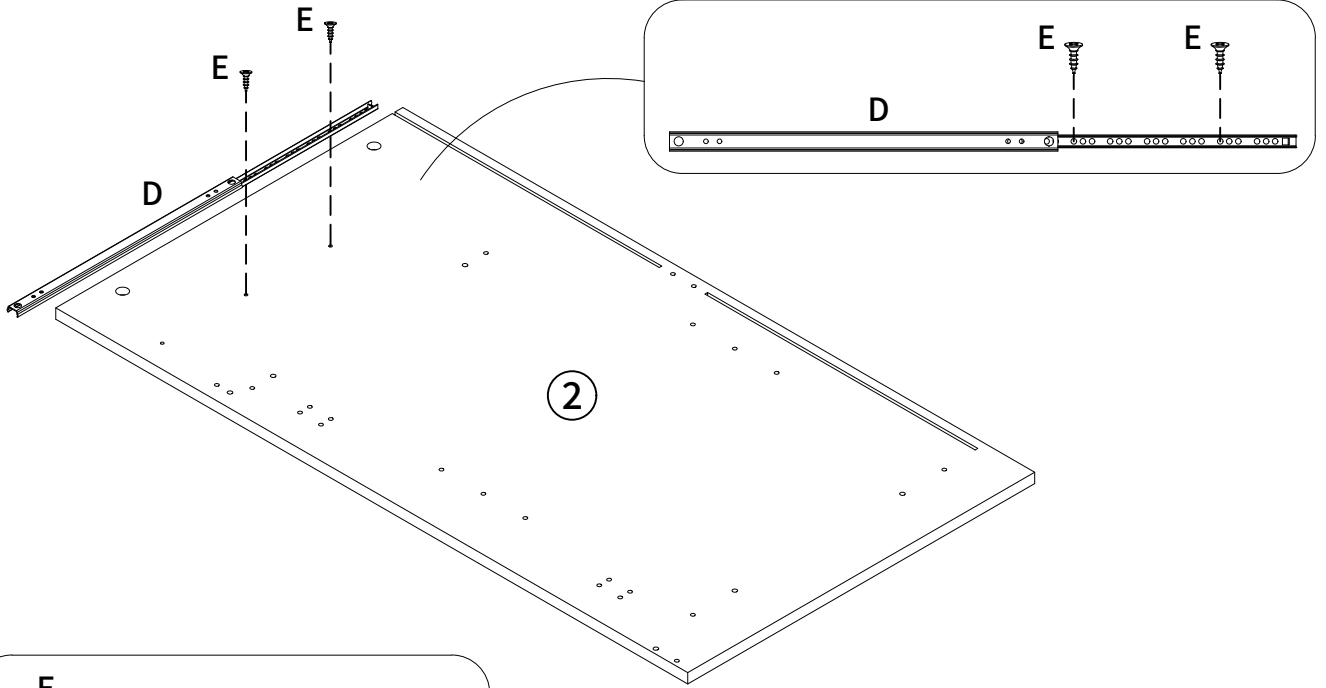

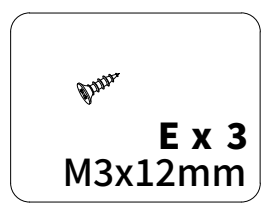
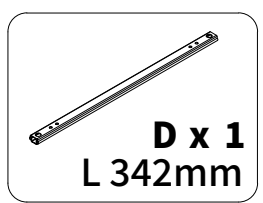
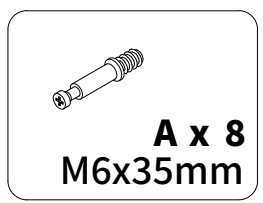
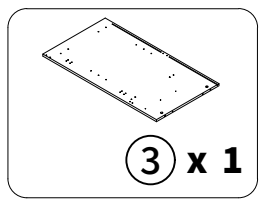
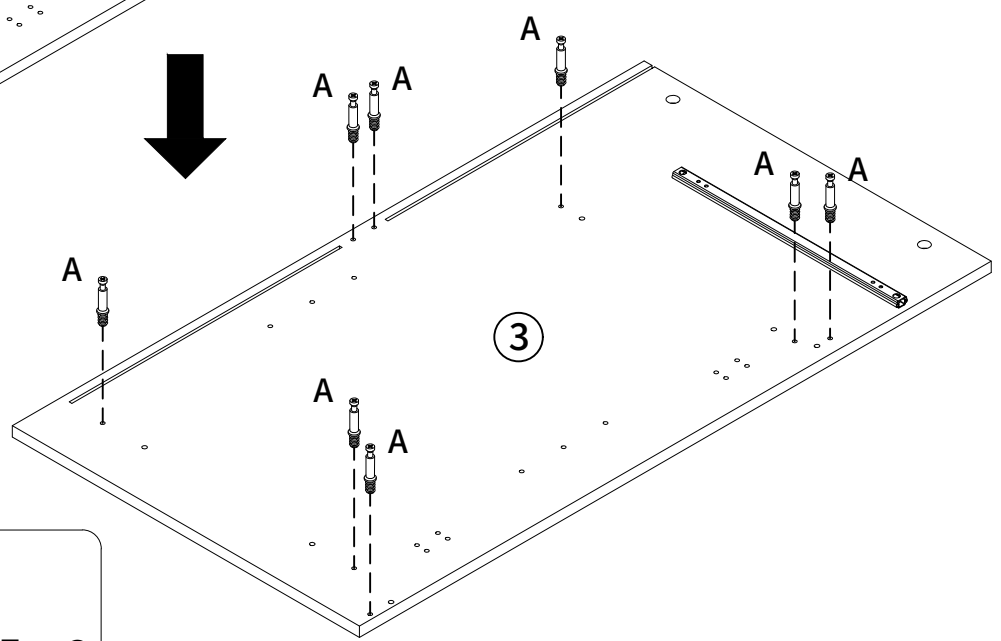
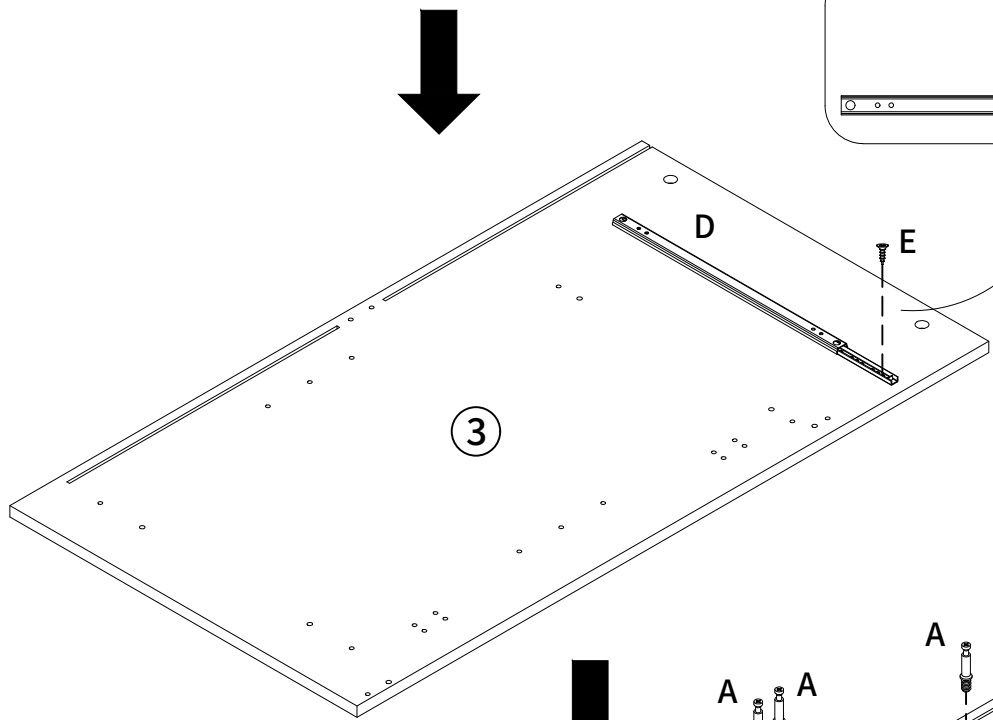
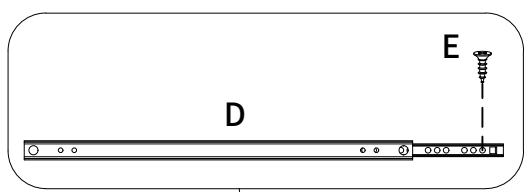
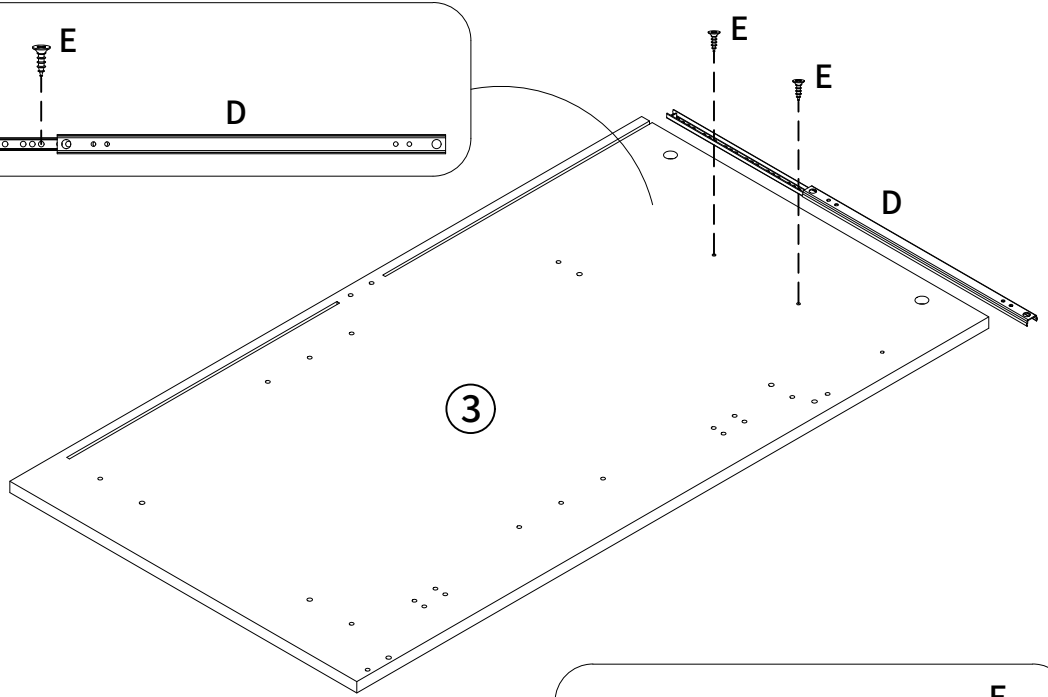
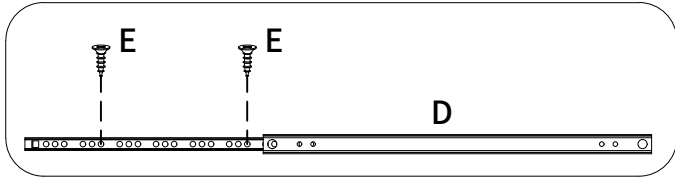

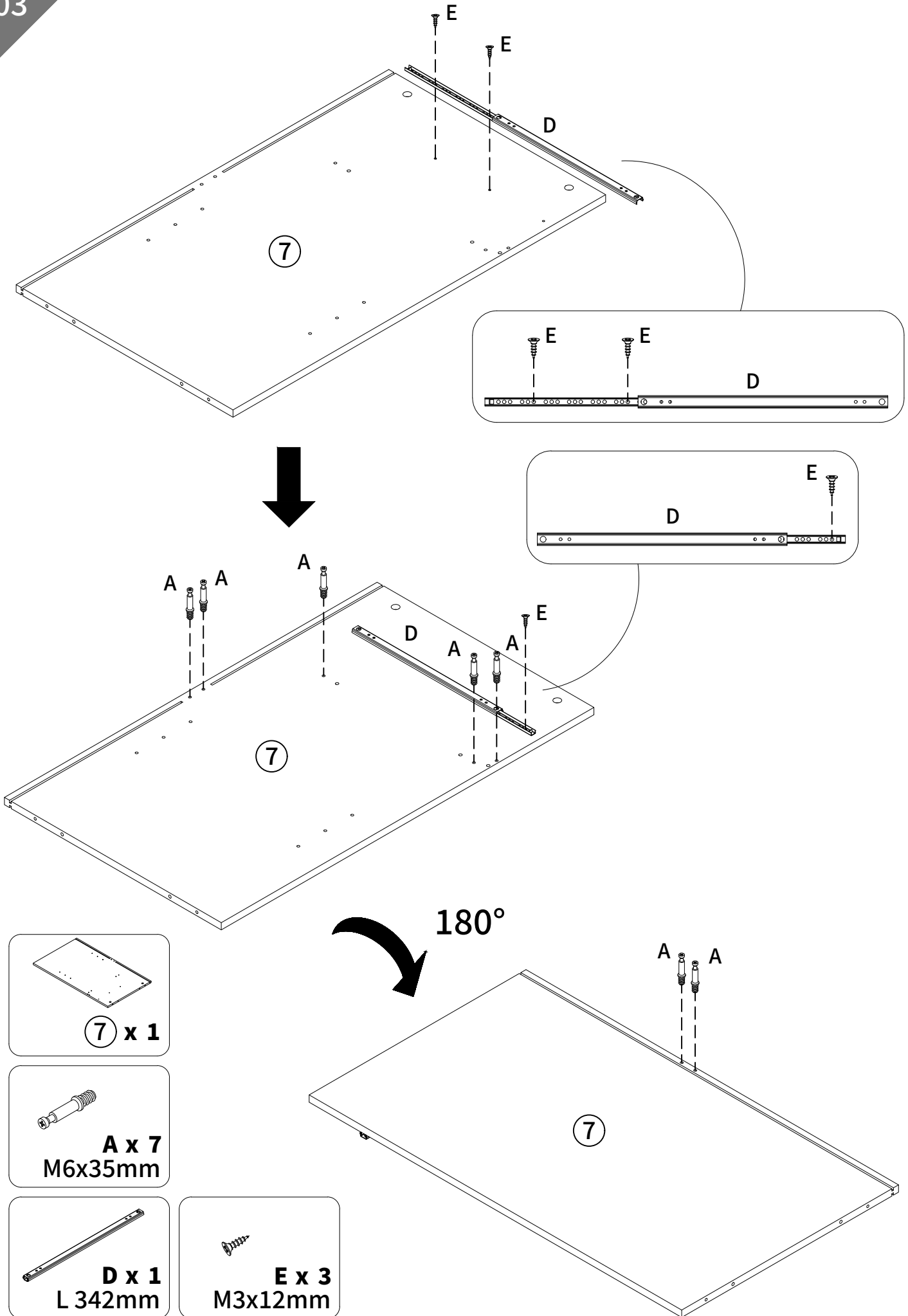

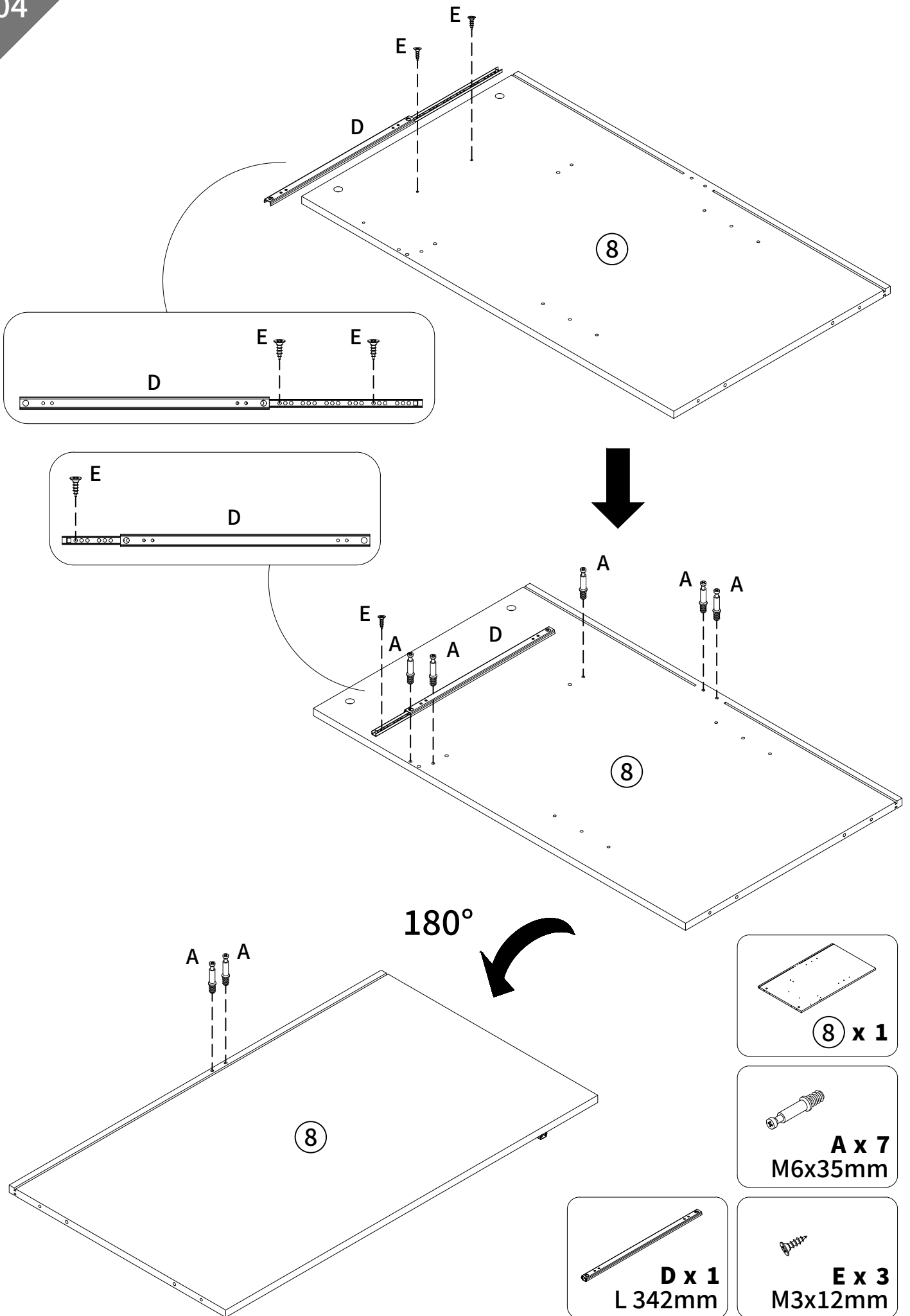

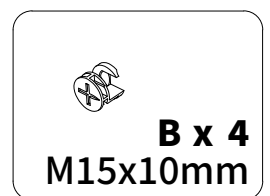
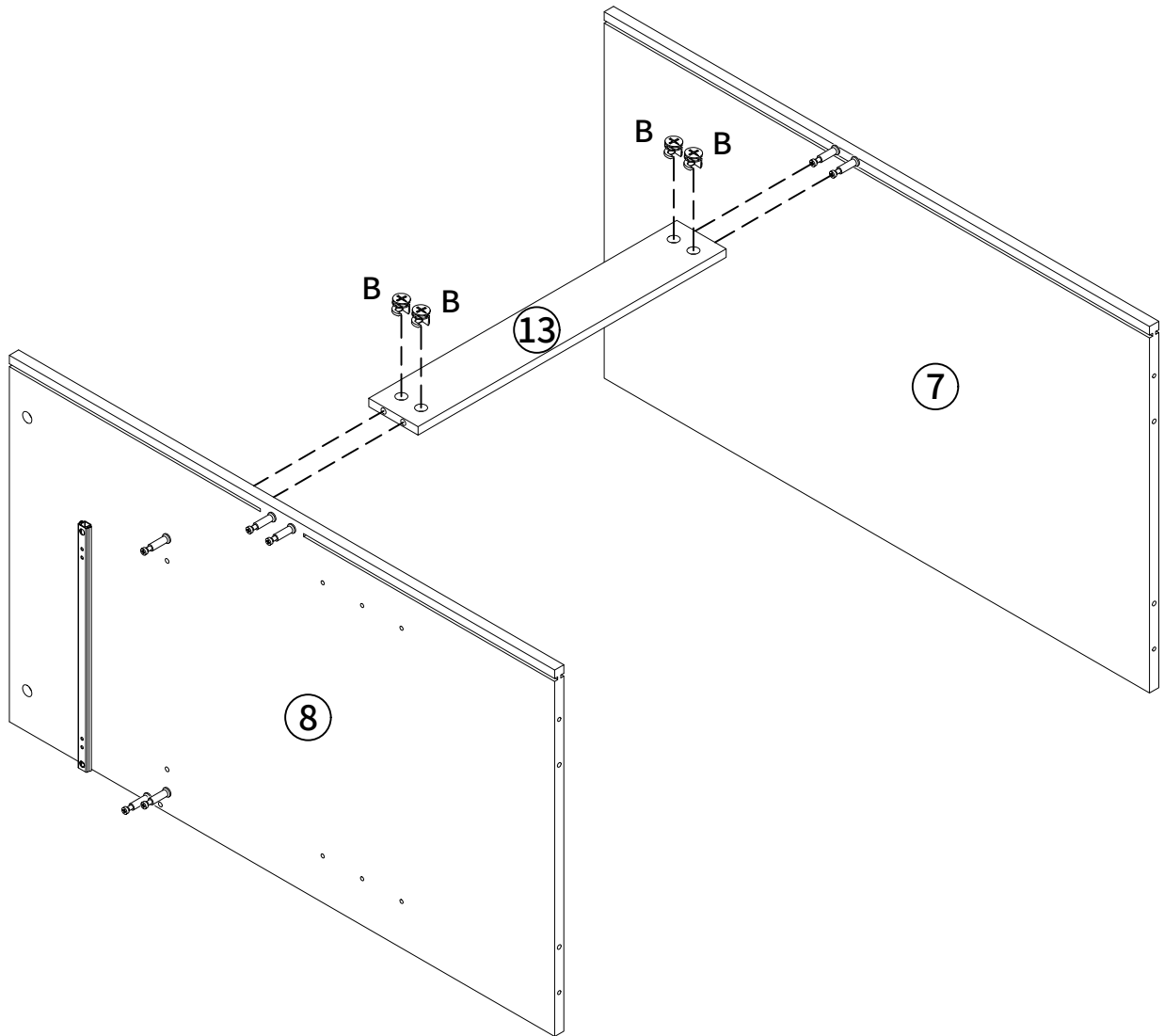

06

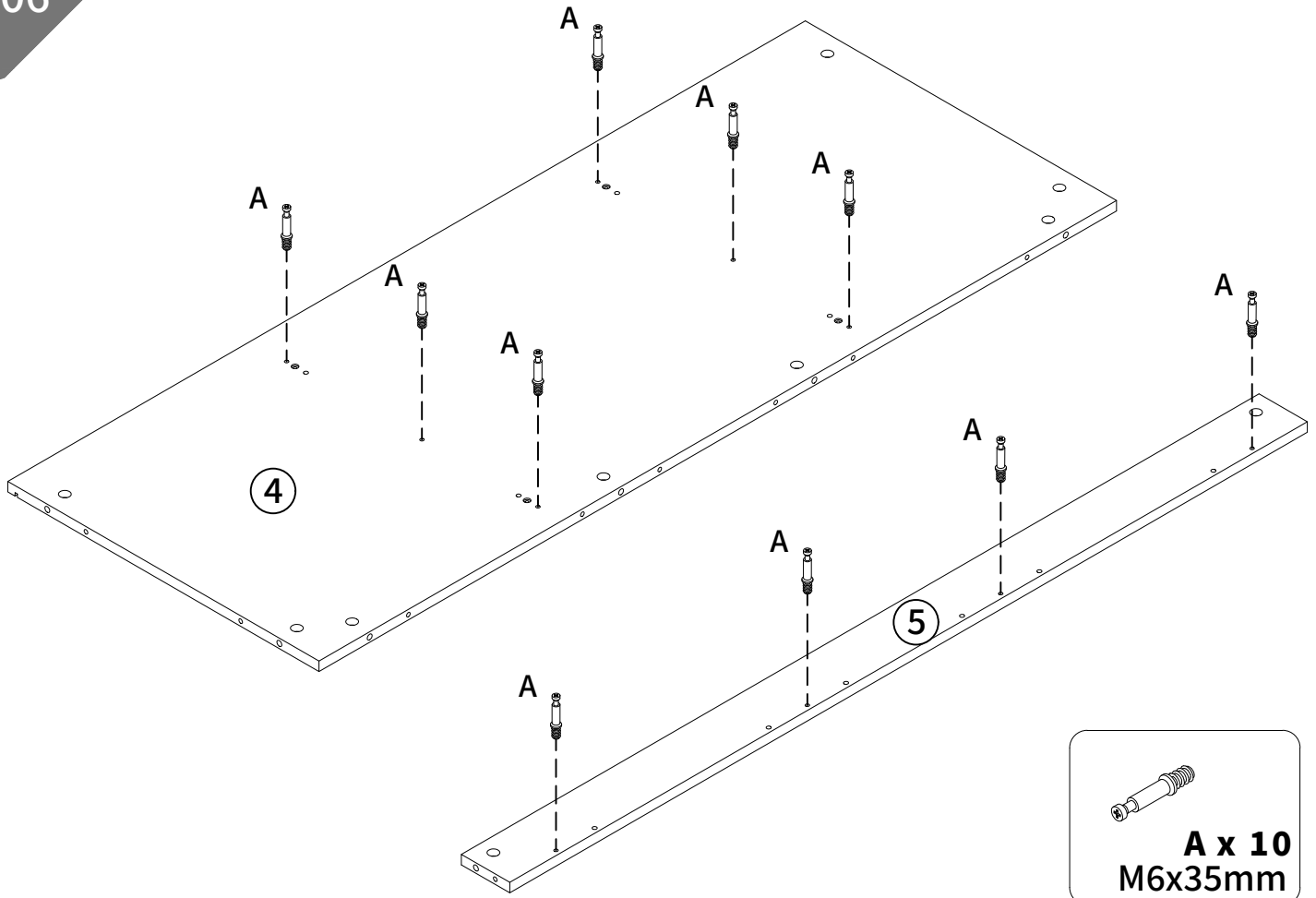

07

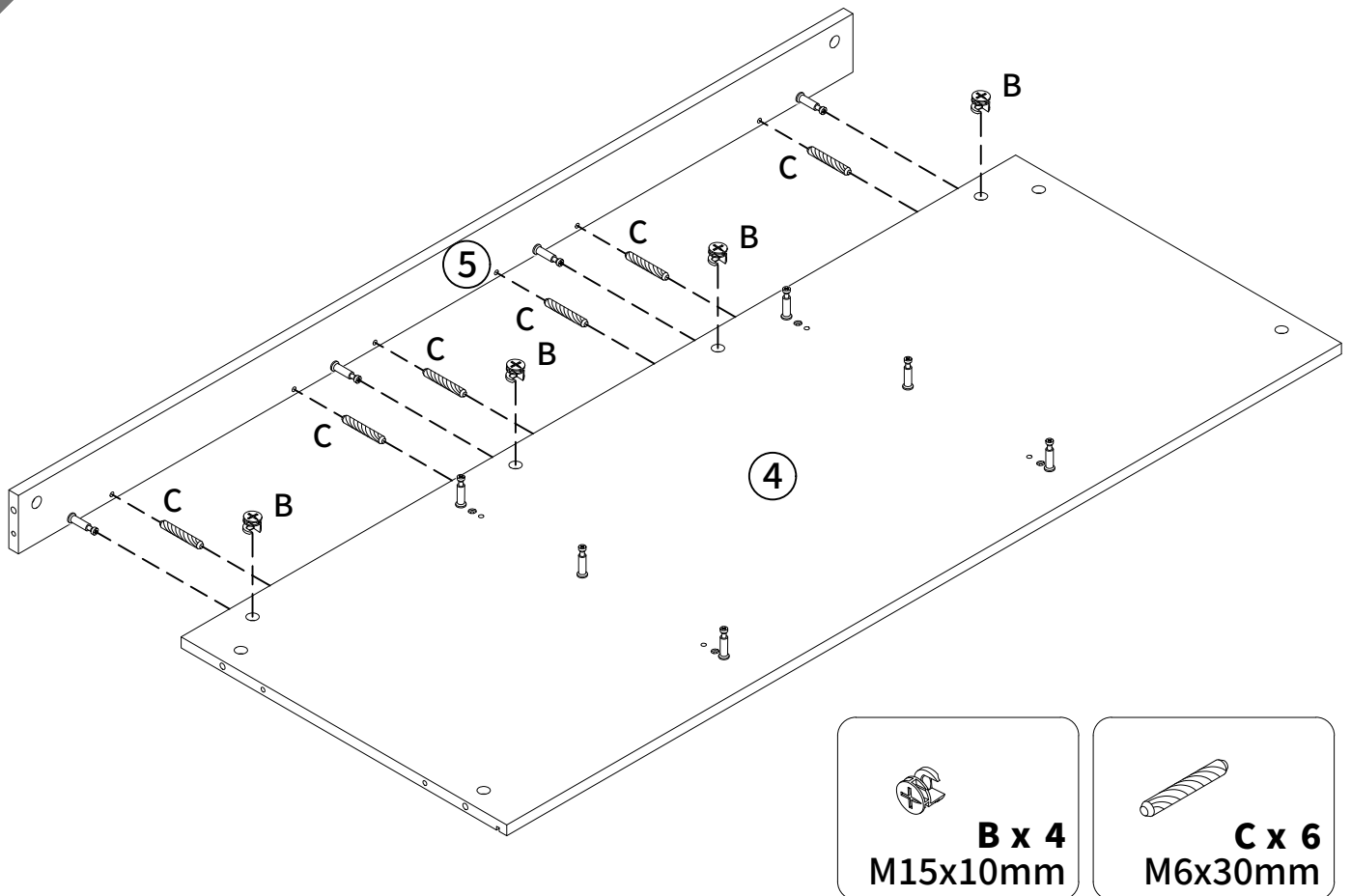

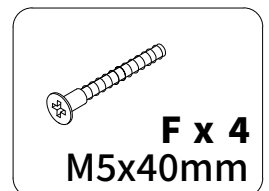
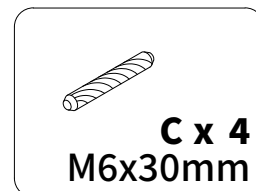
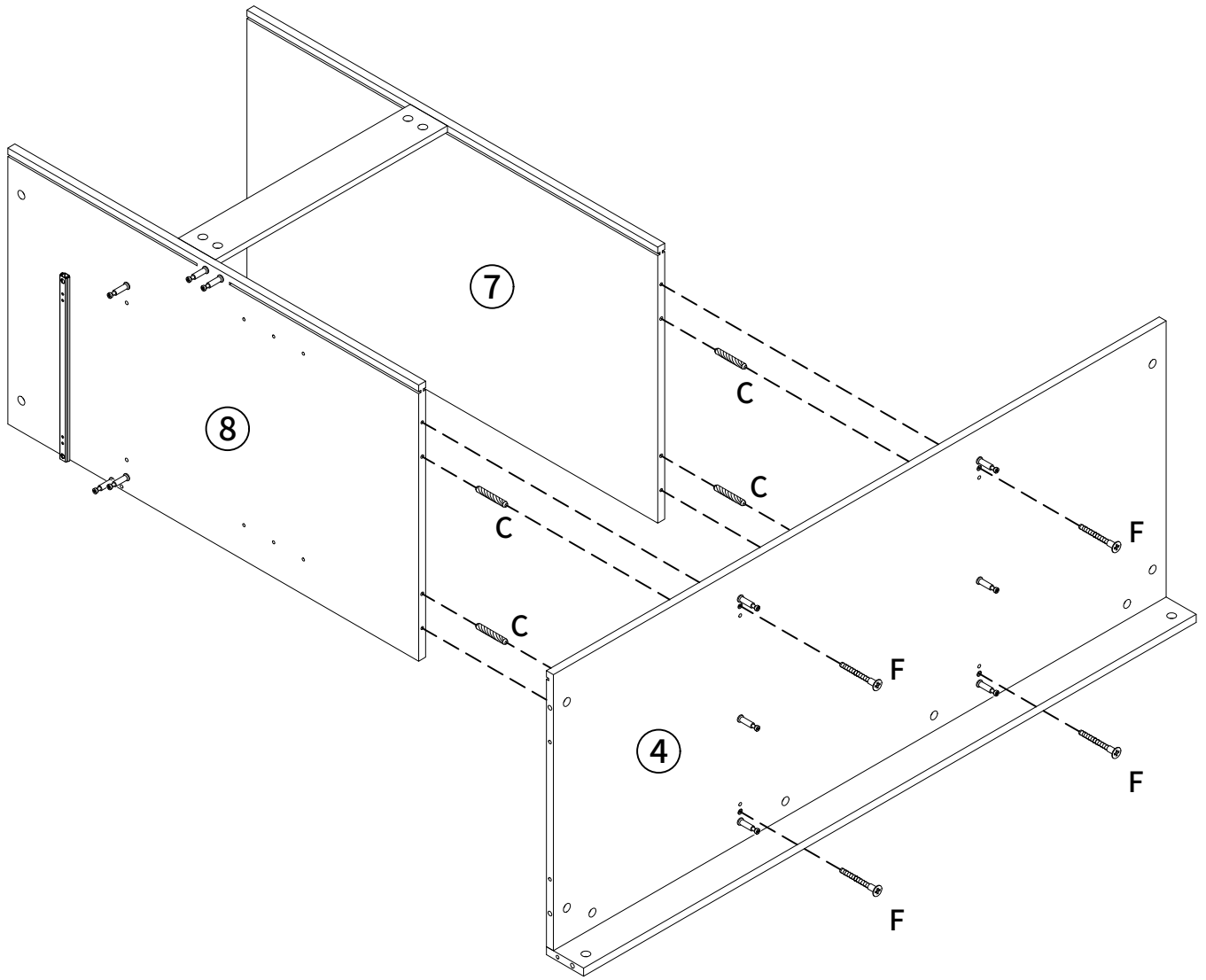

09

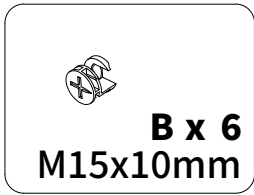
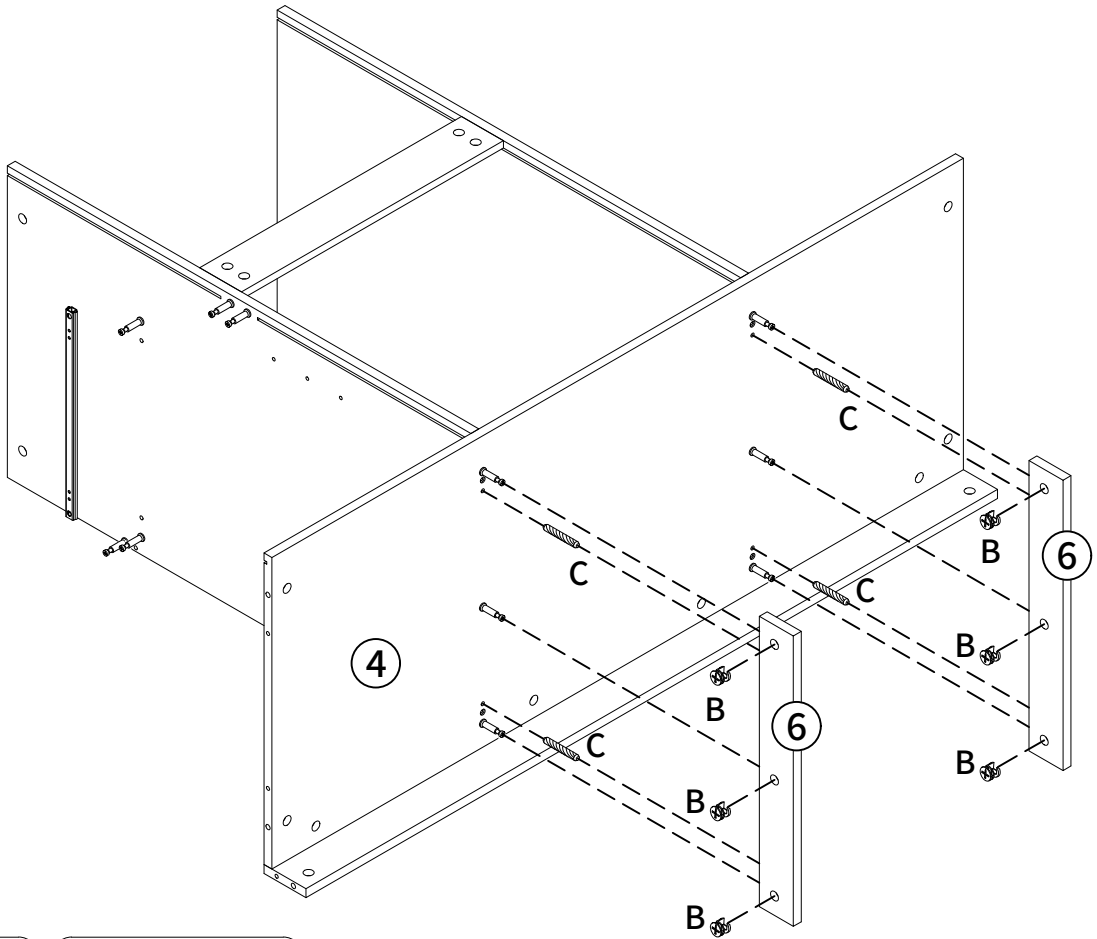

10

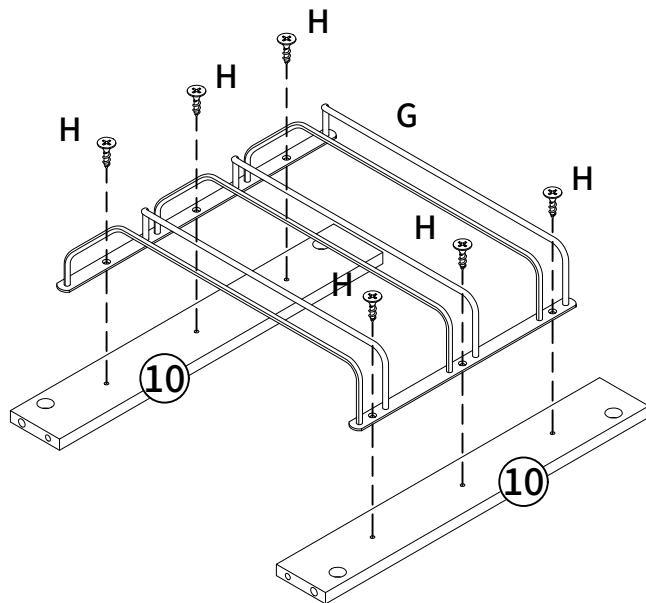

**x2**

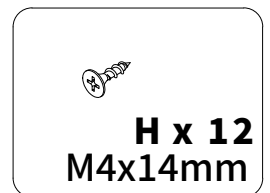
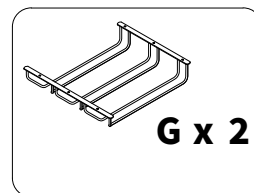

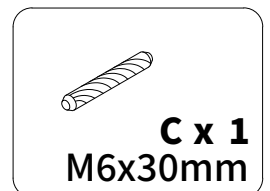
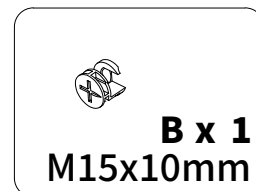
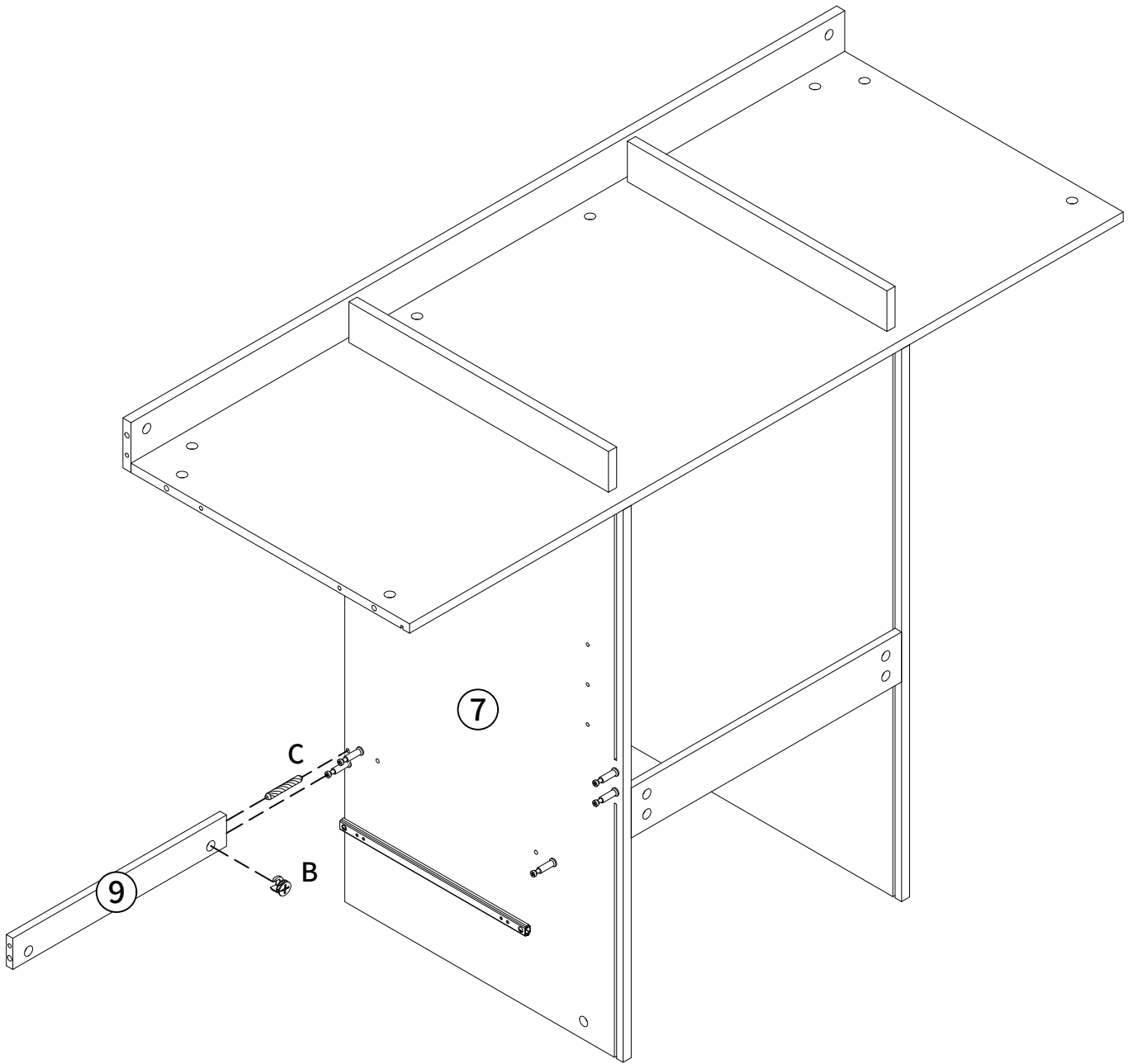
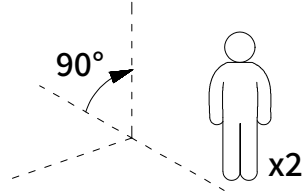
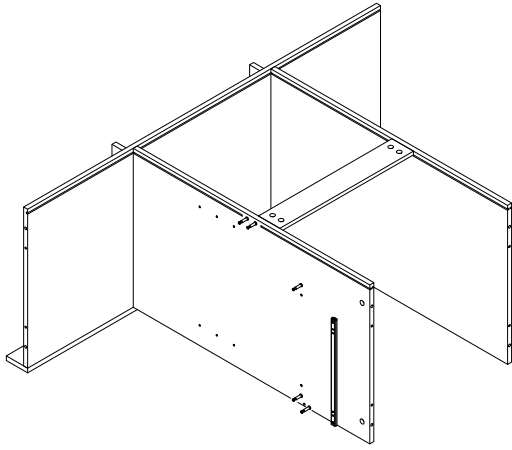

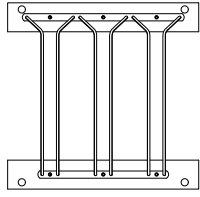

Please pay attention to the installation direction of the Metal Wine Rack (G)

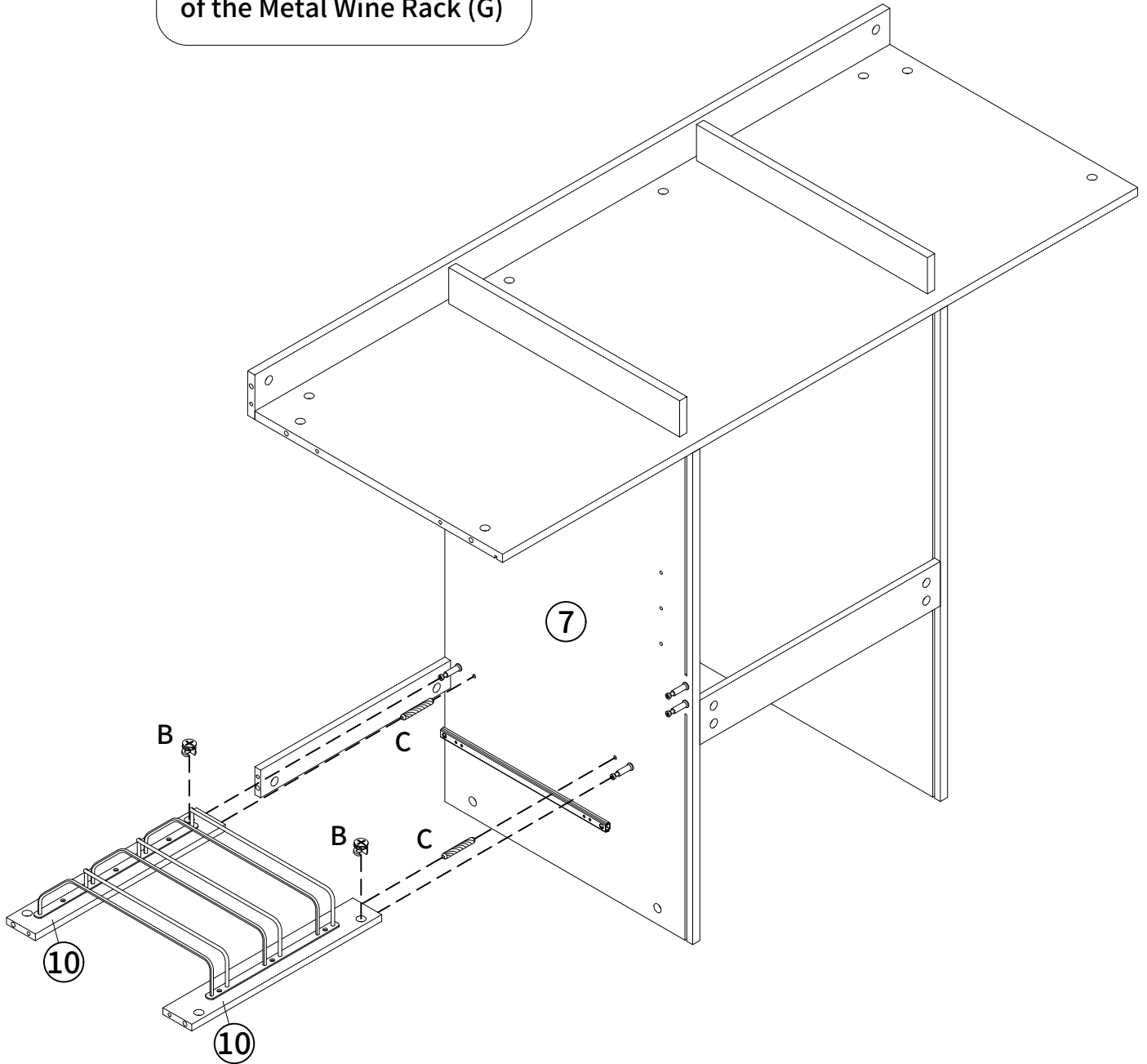

**B x 2**  
M15x10mm

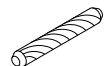

**C x 2**  
M6x30mm

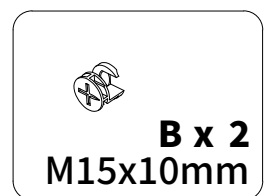
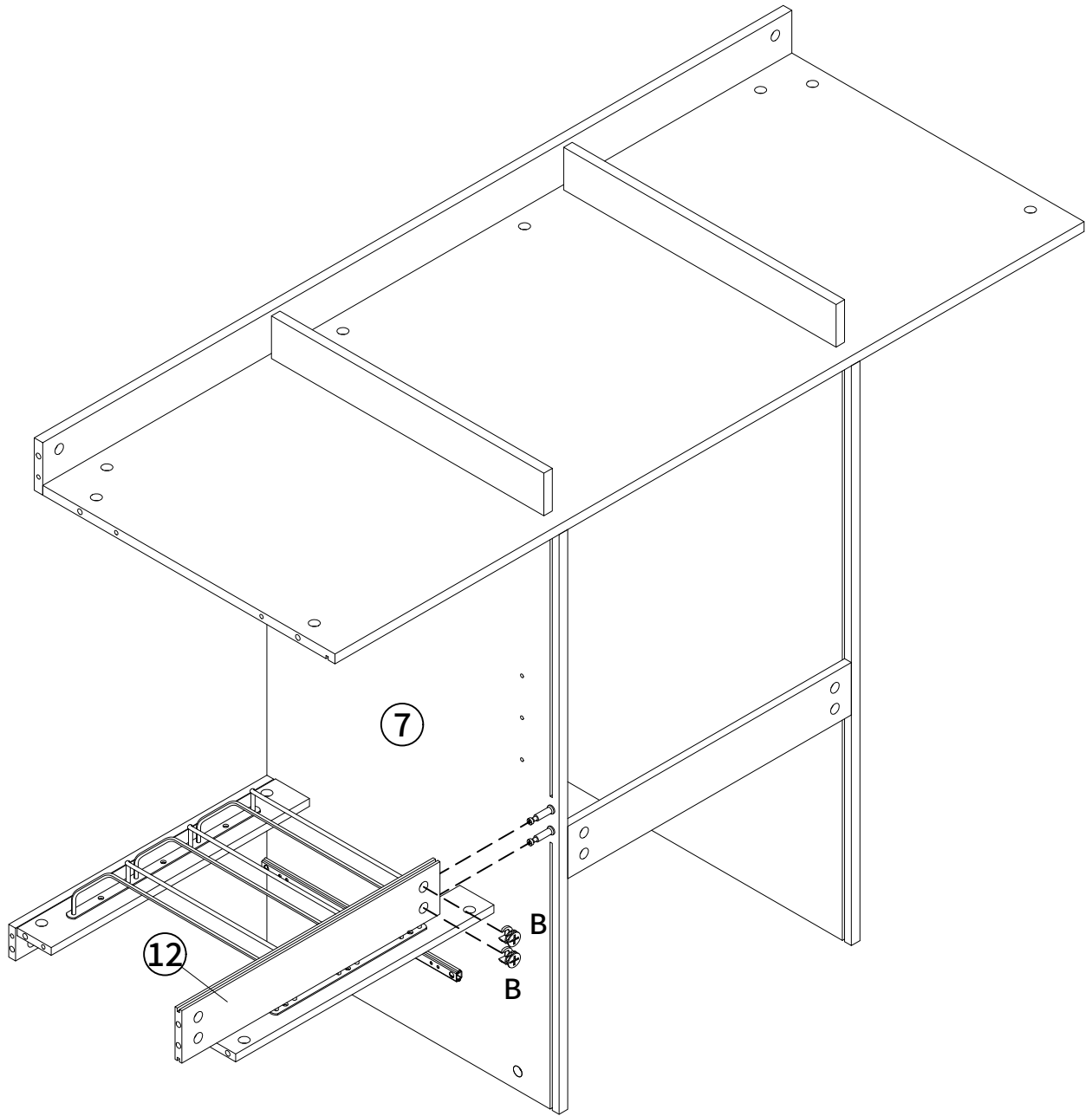

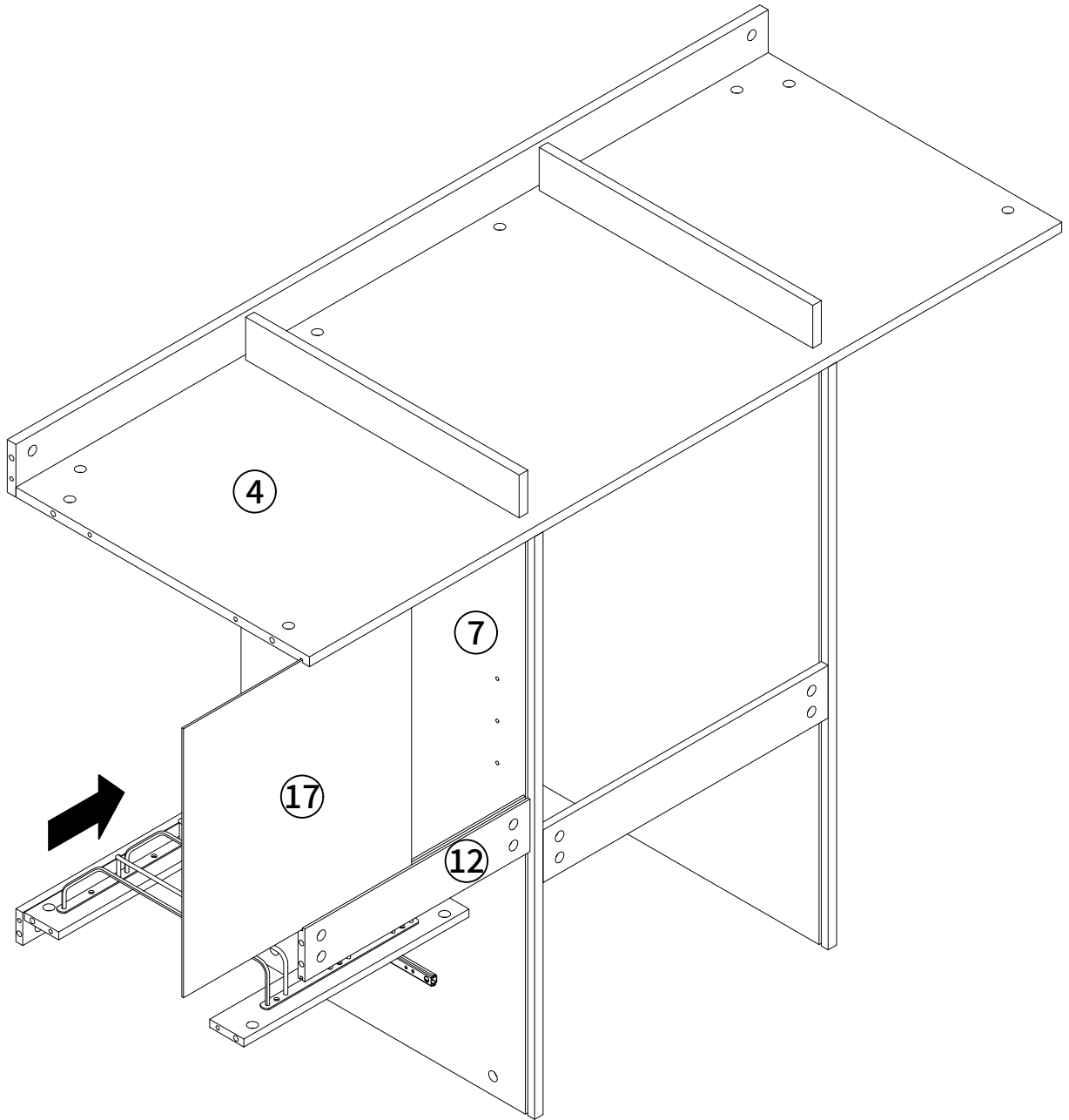

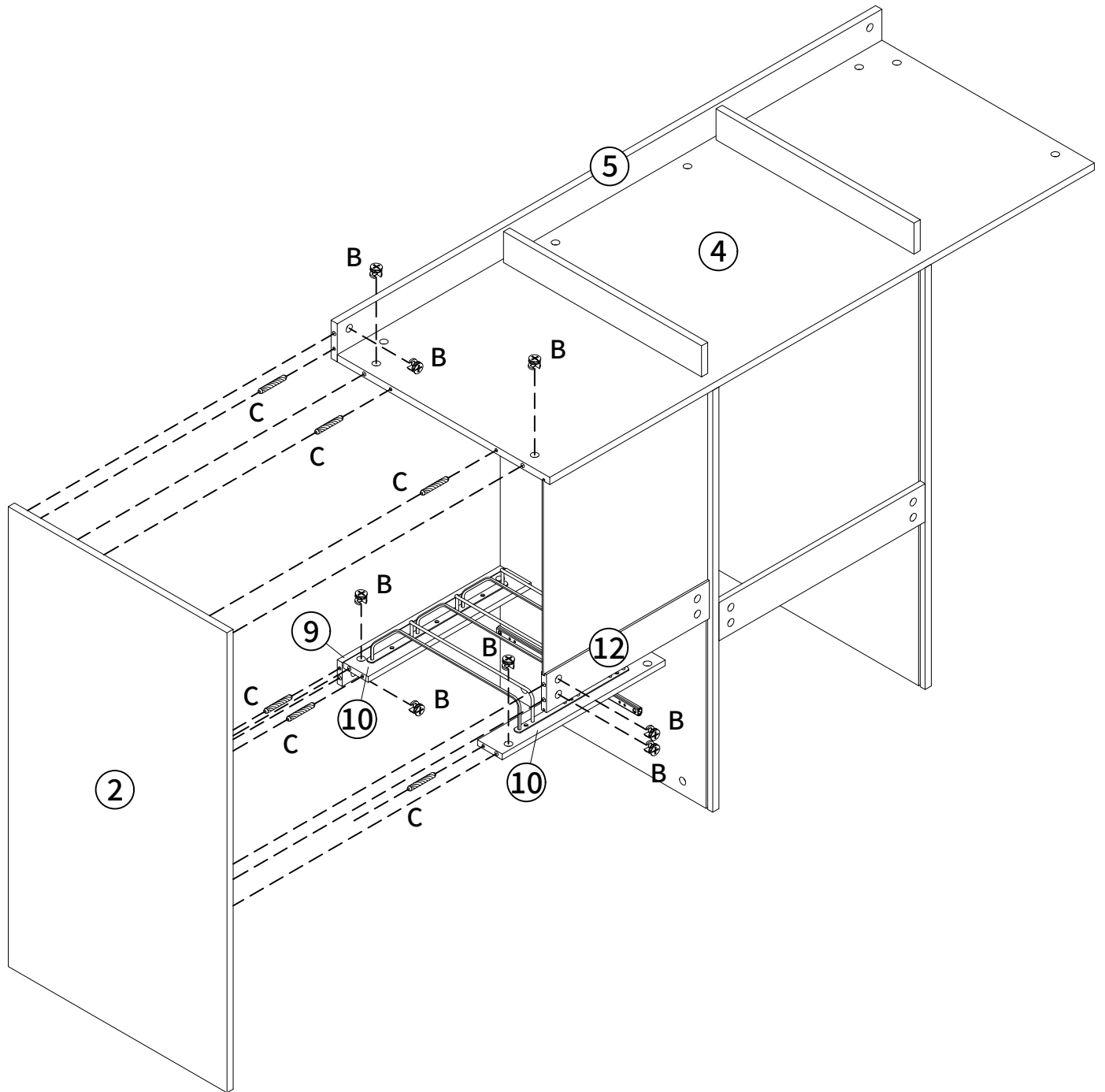

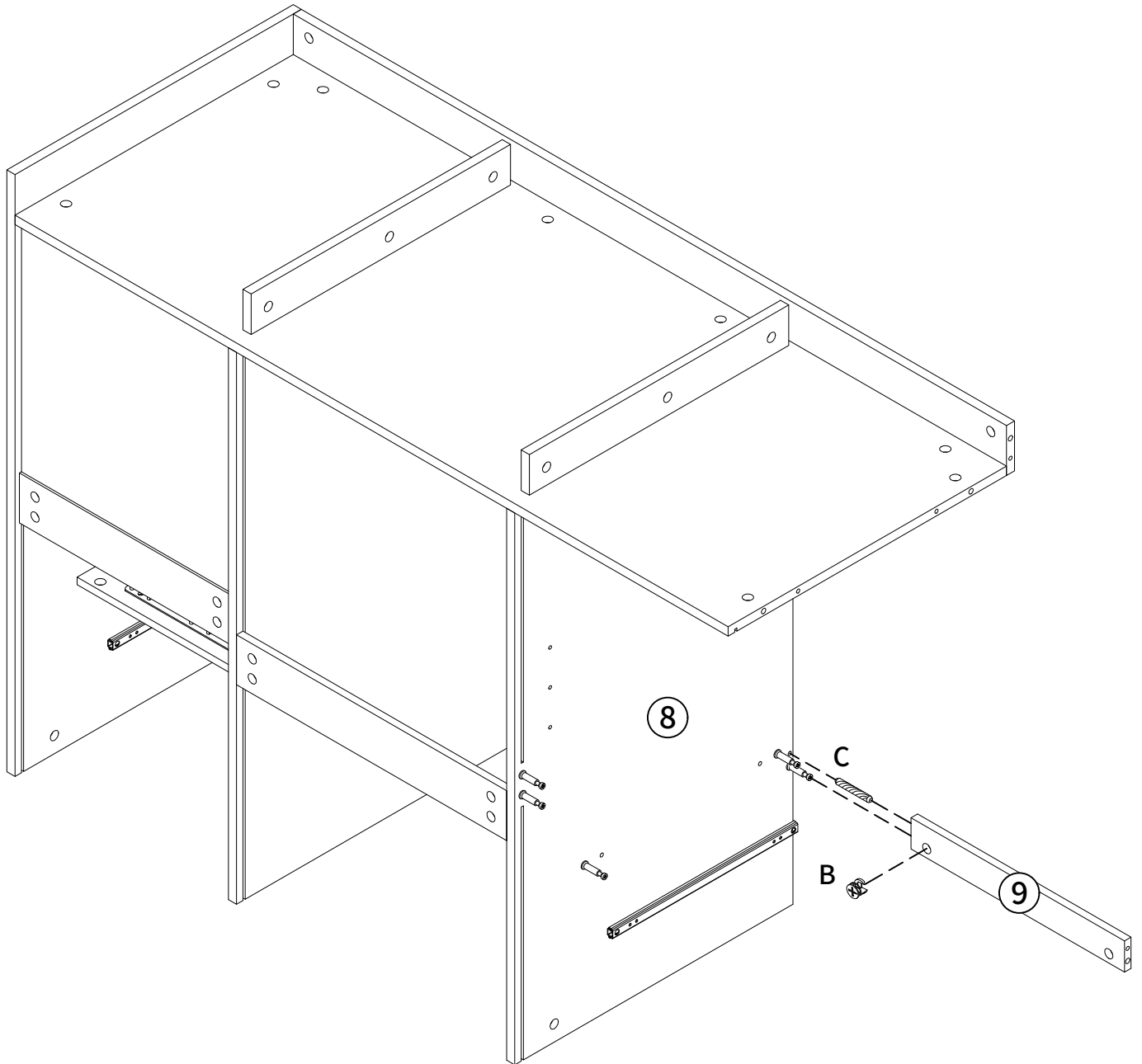

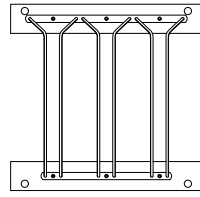

Please pay attention to the installation direction of the Metal Wine Rack (G)

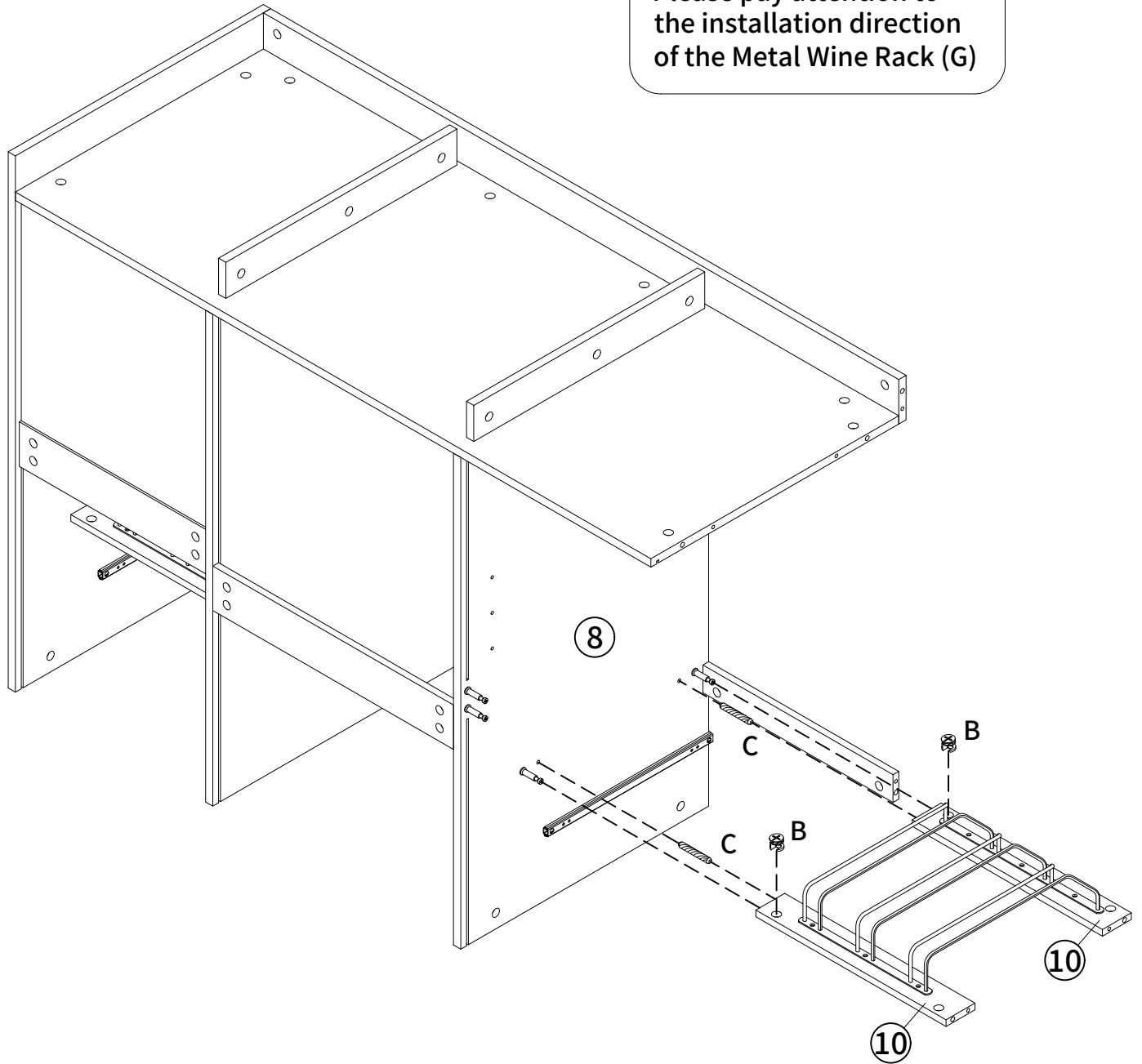

**B x 2**  
M15x10mm



**C x 2**  
M6x30mm

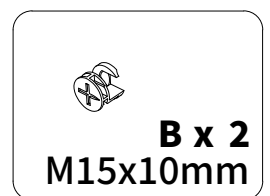
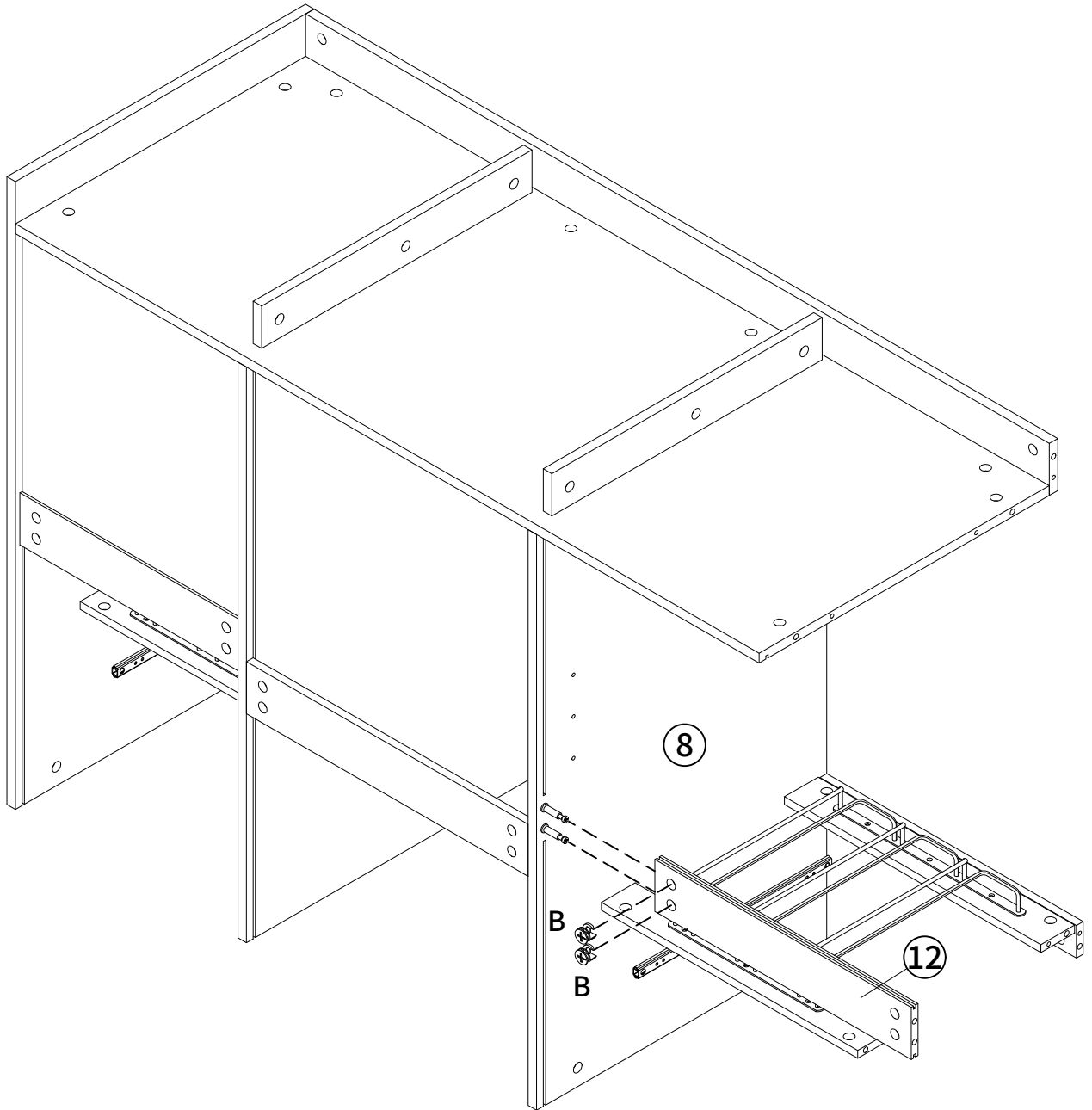

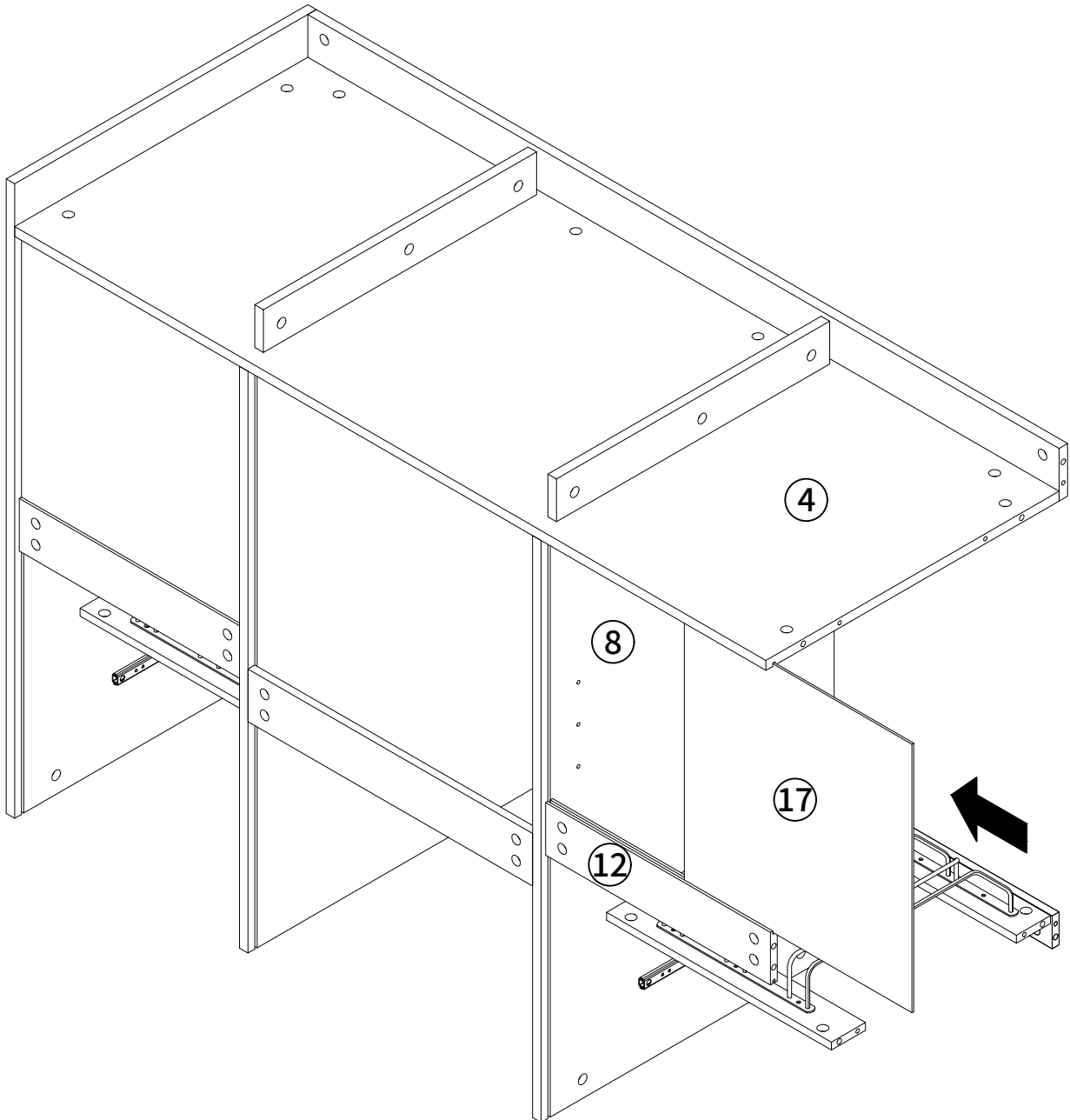

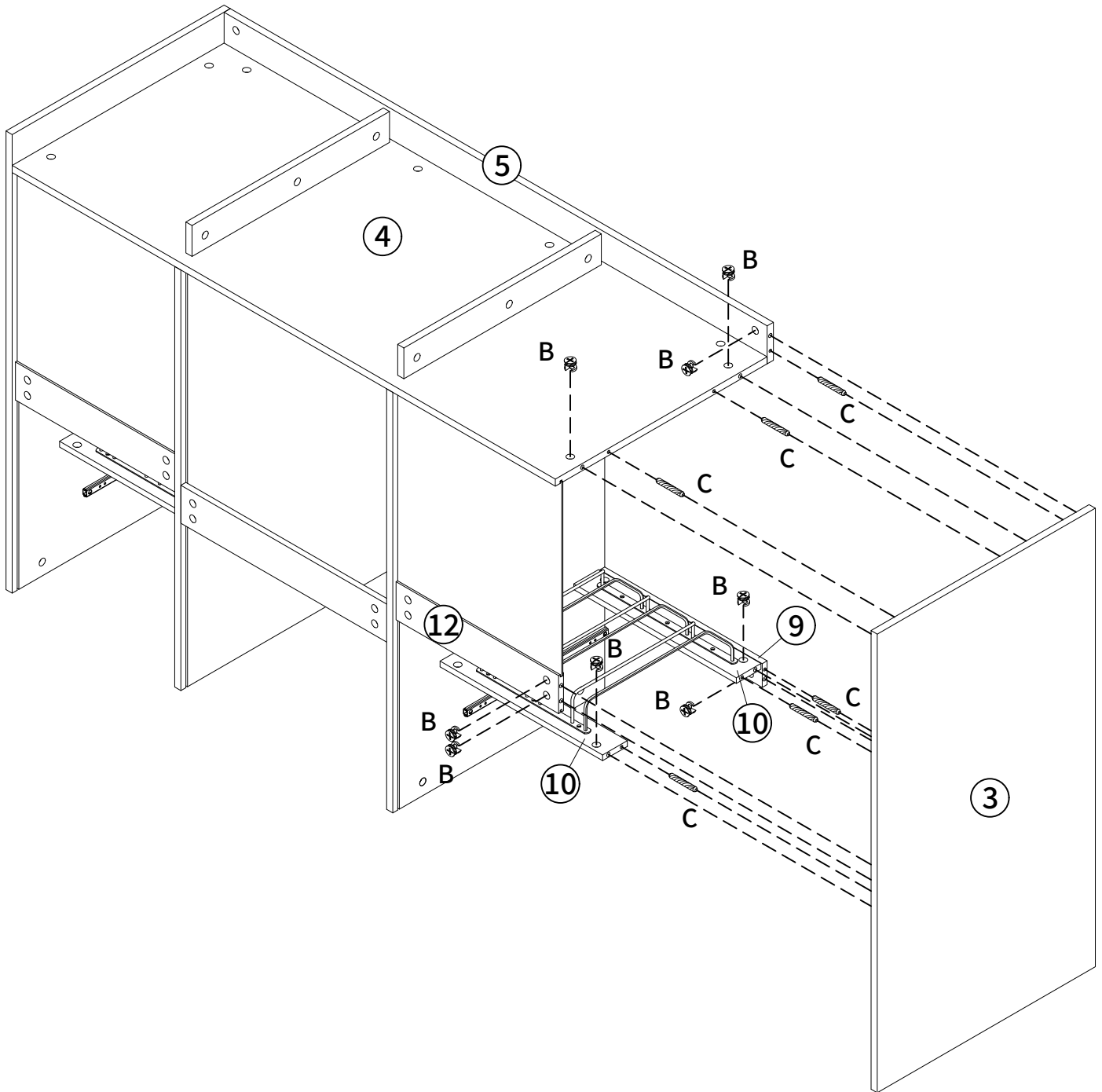

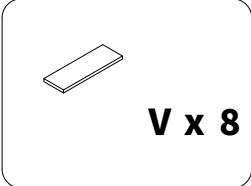
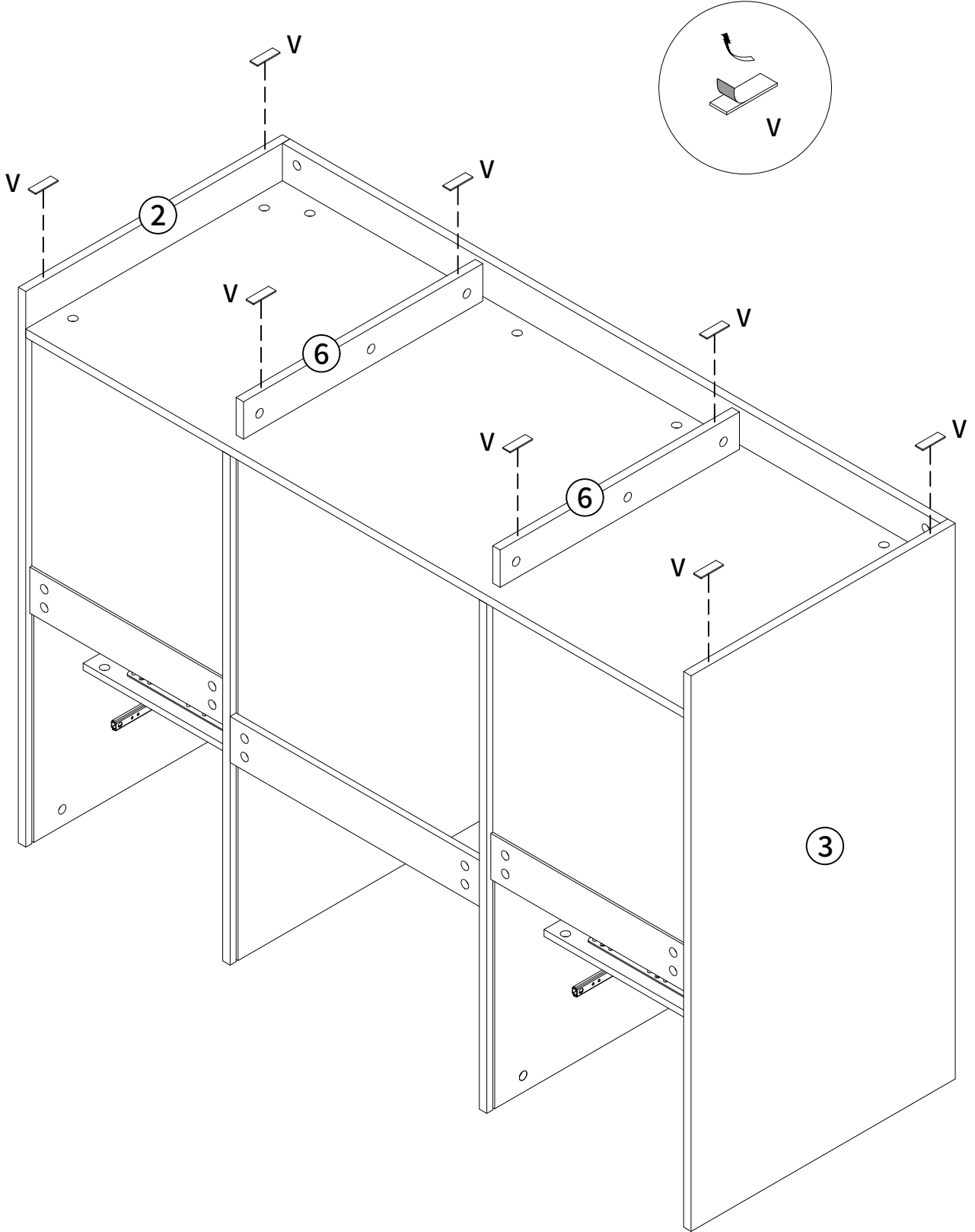

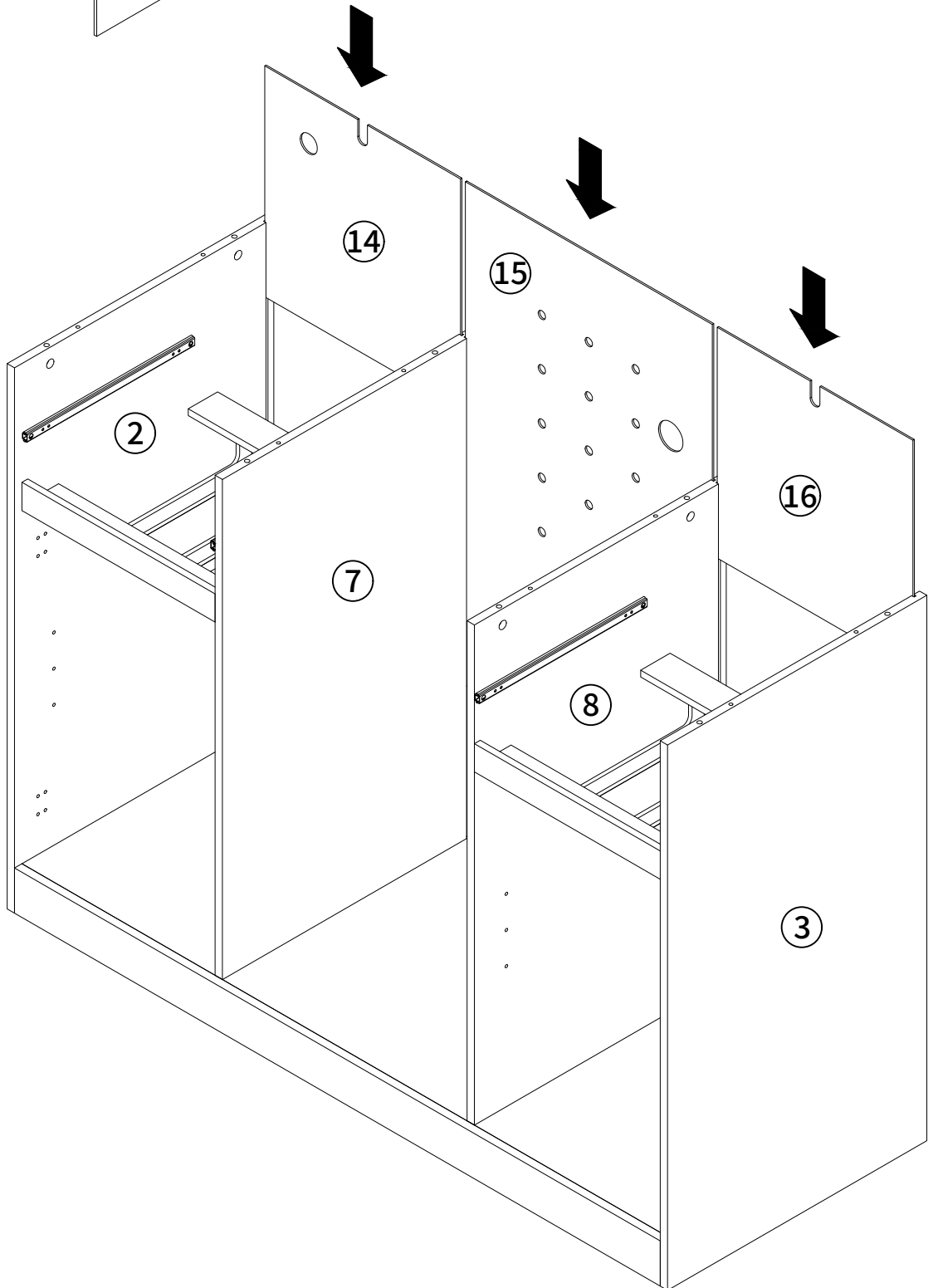
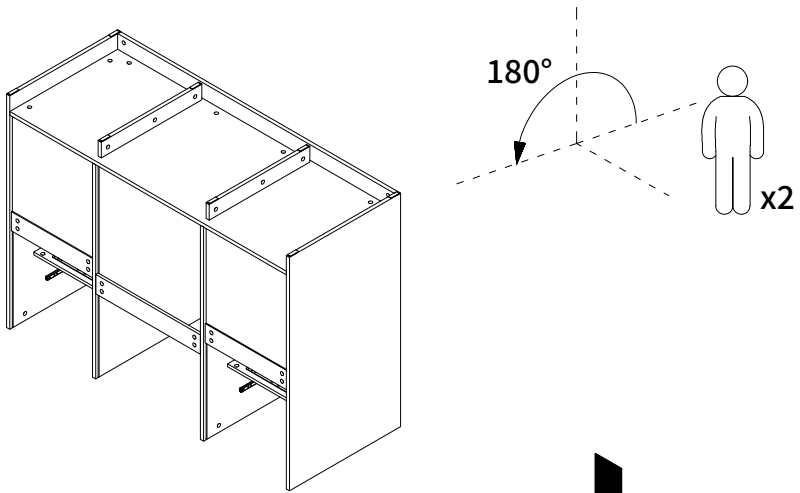

23

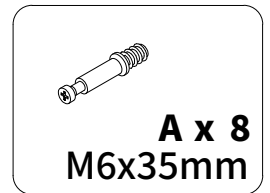
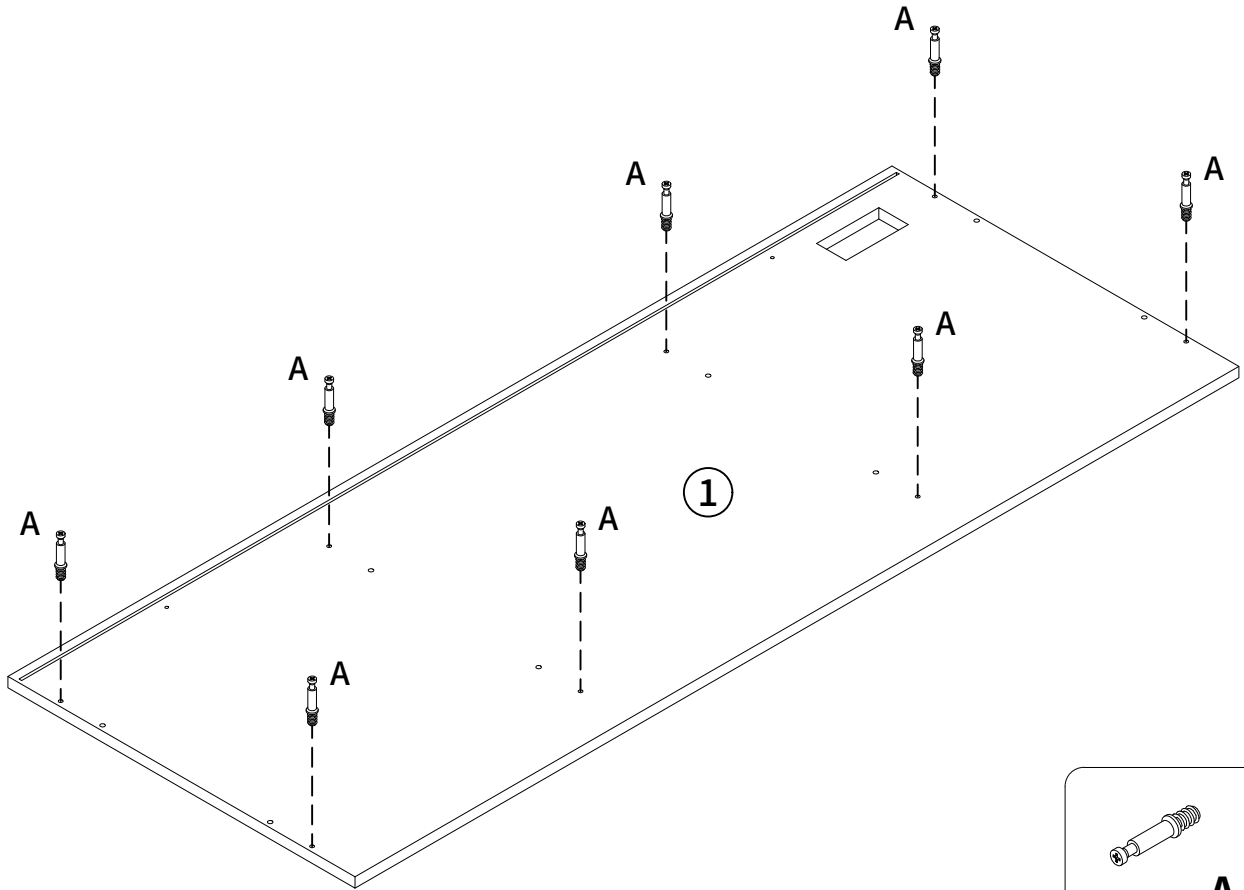

24

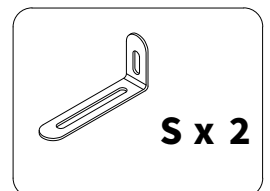
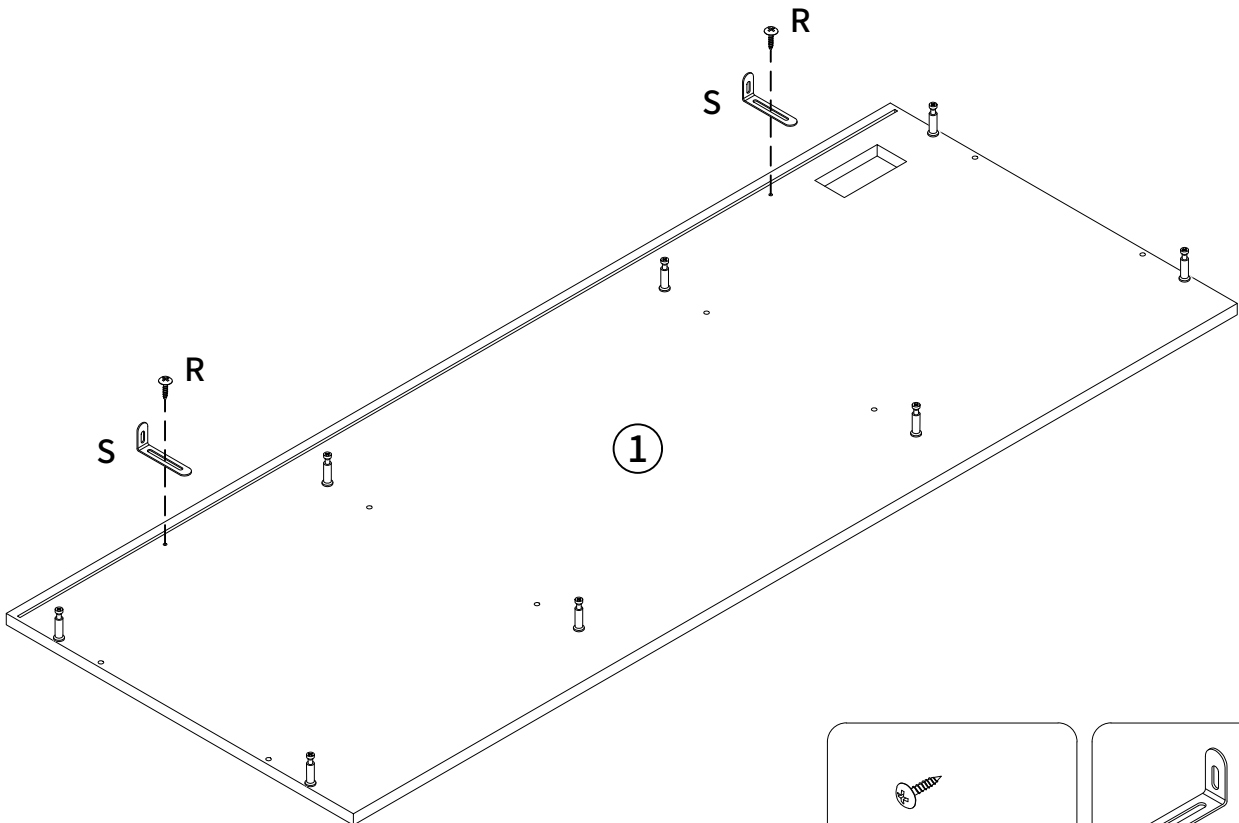

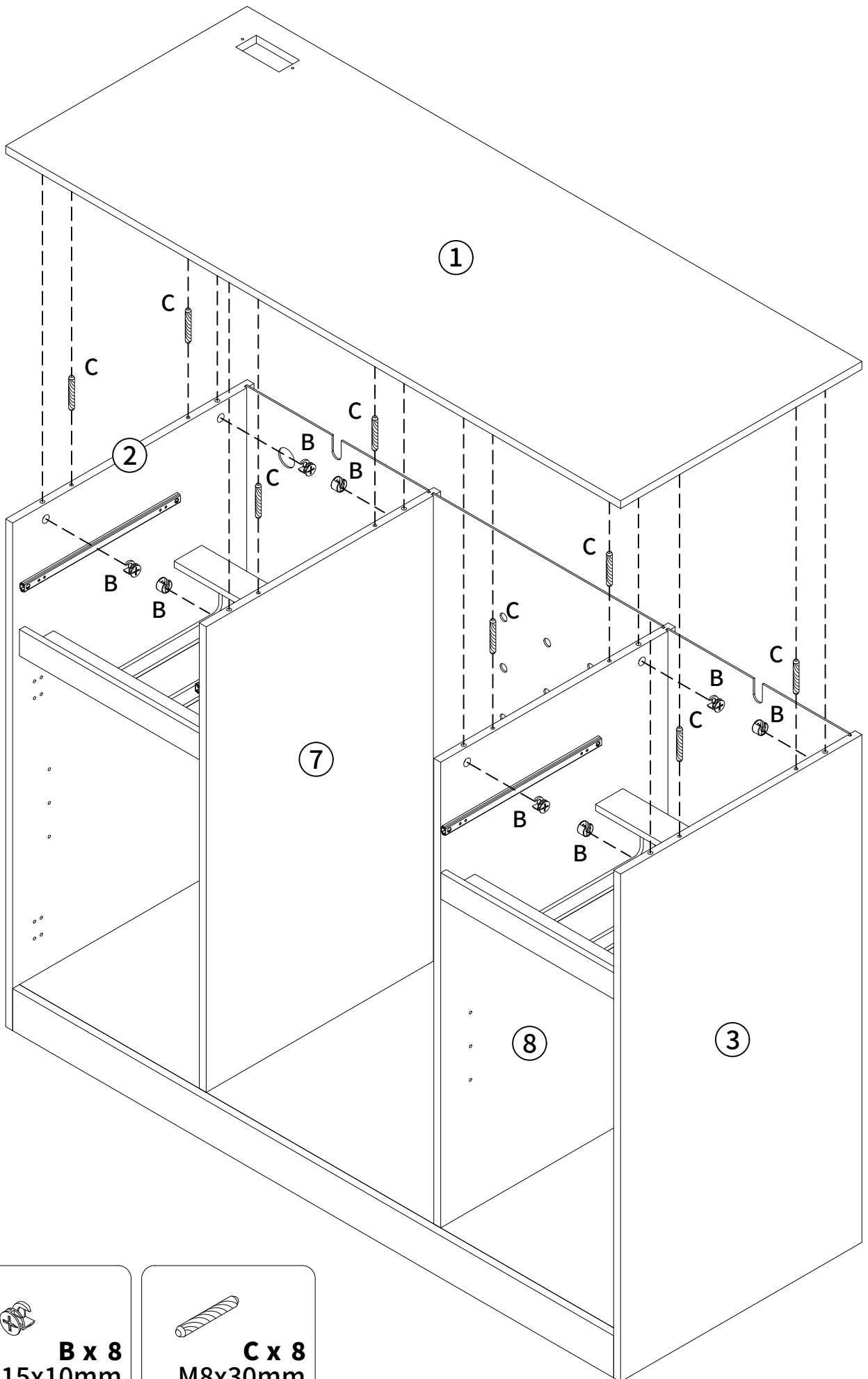

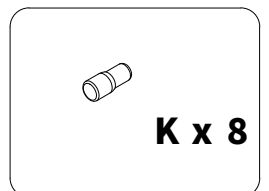
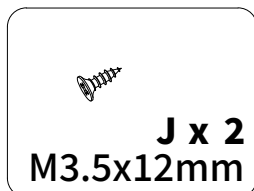
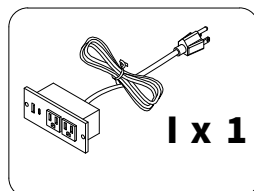
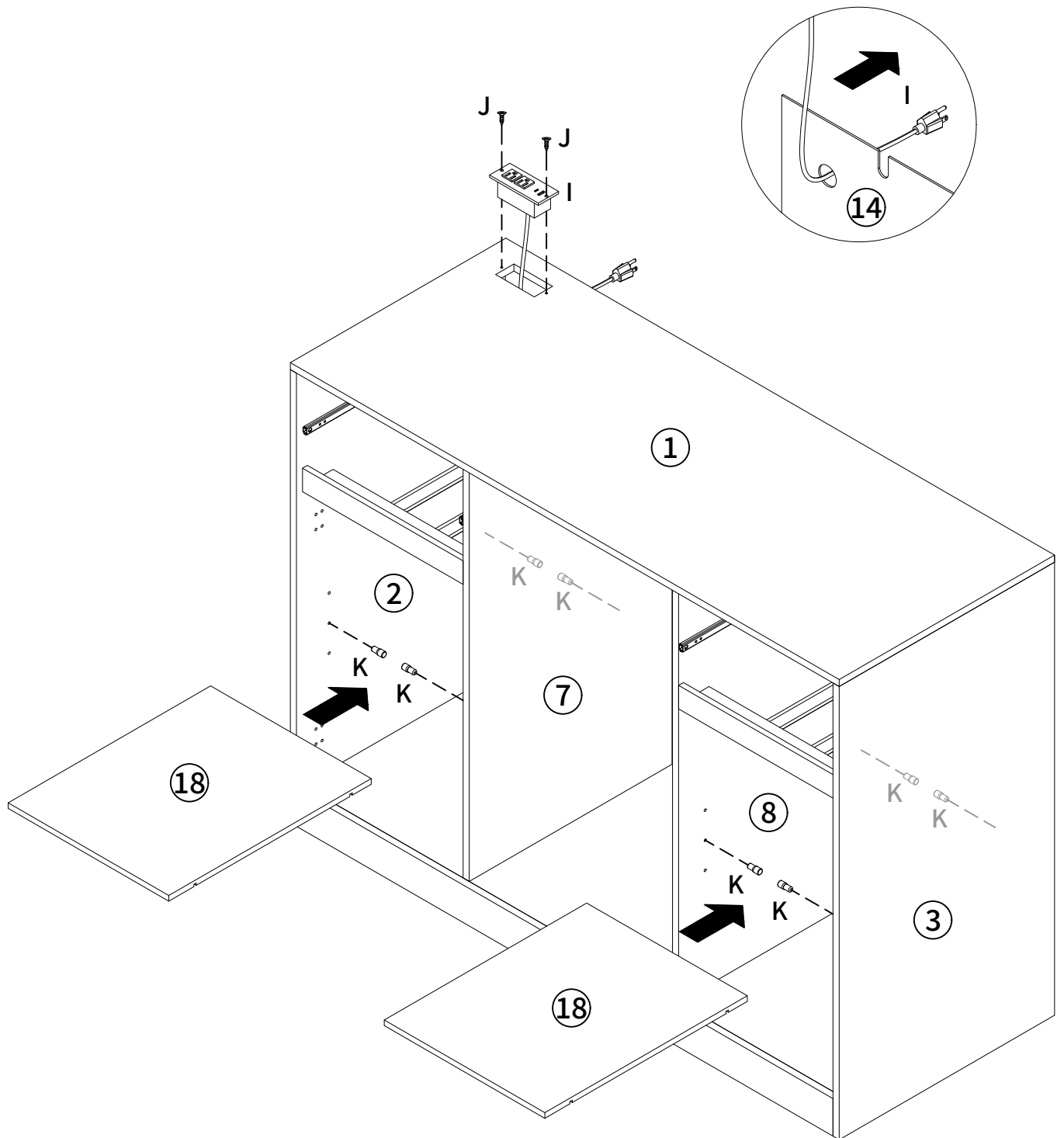

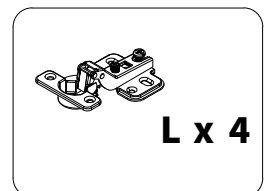
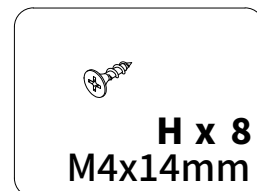
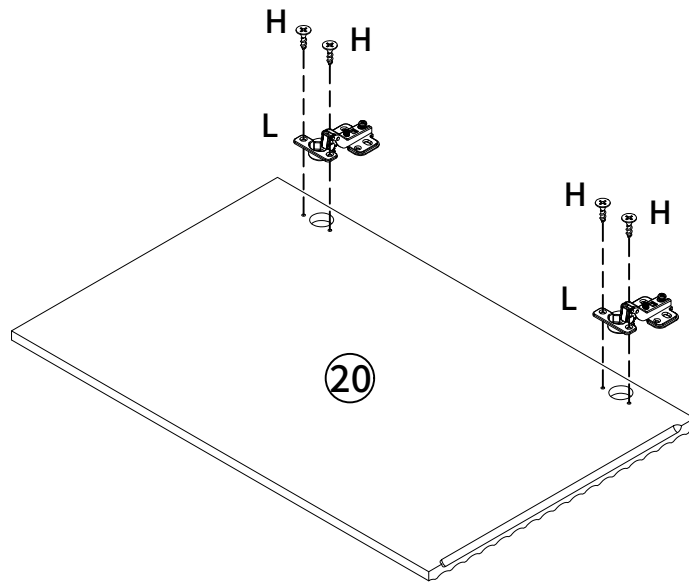
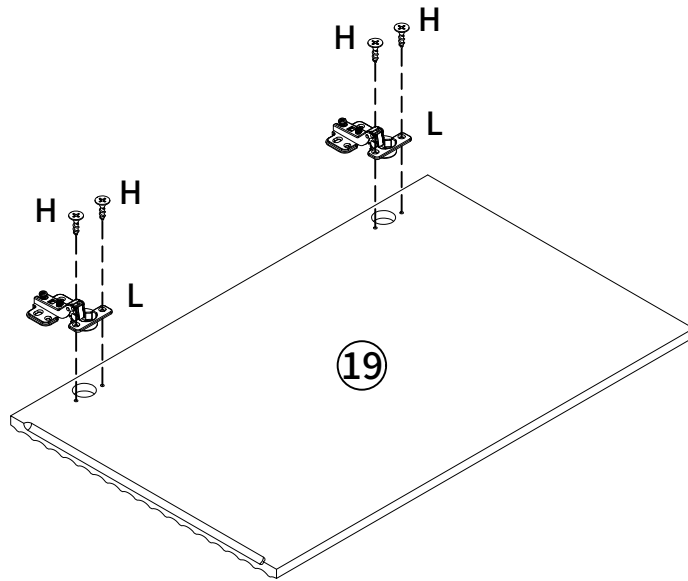

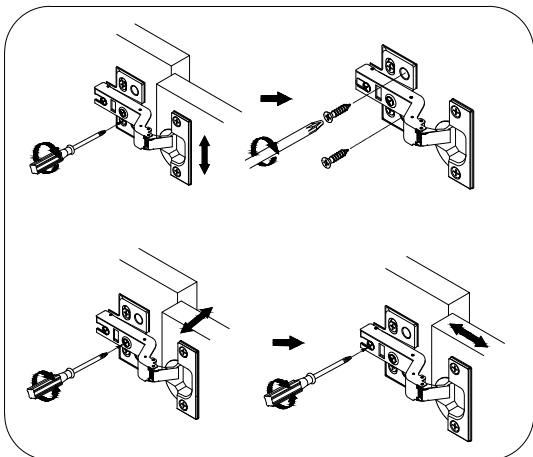
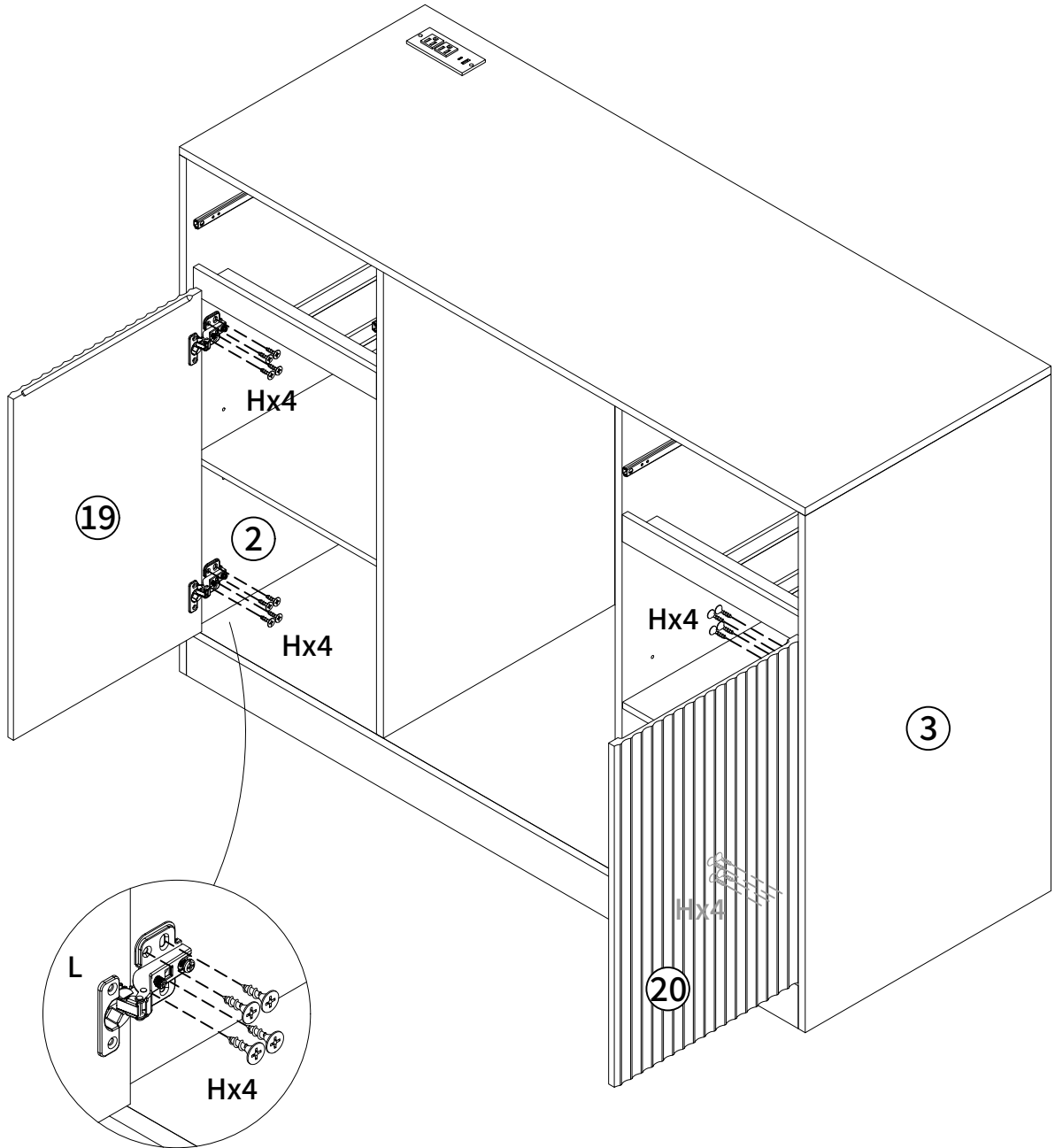

Adjust the screws as shown on the sketch map to ensure all the door gaps are in the same level.

