

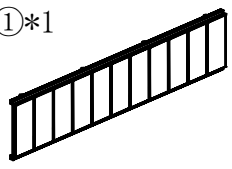

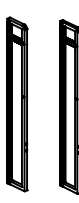





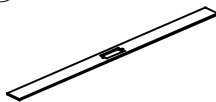

Parts Checking List

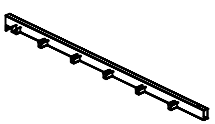
①*1 	②*2 	③*1 	④*1 	⑤*1 	⑥*1 
⑦*1 	⑧*1 	⑨*2 	⑩*1 	⑪*1 	⑫*1 
⑬*2 	⑭*2 	⑮*1 	⑯*2 	⑰*1 	⑱*10 
A*22  M8*30	B*8  M8*16	C*7  M8*50	D*8  M4*20 Tapping		

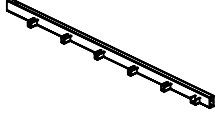
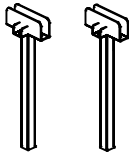
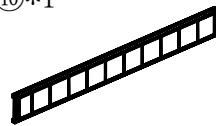
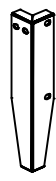
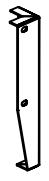
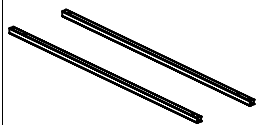
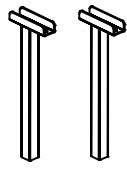
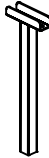
- ① Headboard
- ② Wings
- ③ Back Retainer
- ④ Shelf
- ⑤ Front/Left Rail
- ⑥ Front/Right Rail
- ⑦ Rear/Left Rail
- ⑧ Rear/Right Rail
- ⑨ Rails Middle Leg
- ⑩ Footboard
- ⑪ Rear Left Leg
- ⑫ Rear Right Leg
- ⑬ Middle Beam
- ⑭ Front/Rear Leg for Beam
- ⑮ Middle Leg for Beam
- ⑯ Front/Rear Bar
- ⑰ Middle Bar
- ⑱ Slats

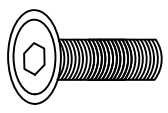
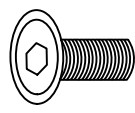
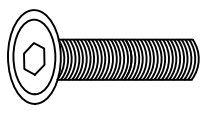
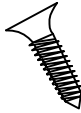
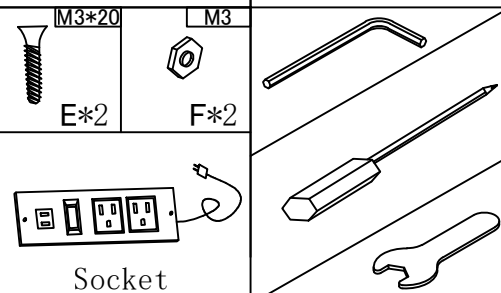
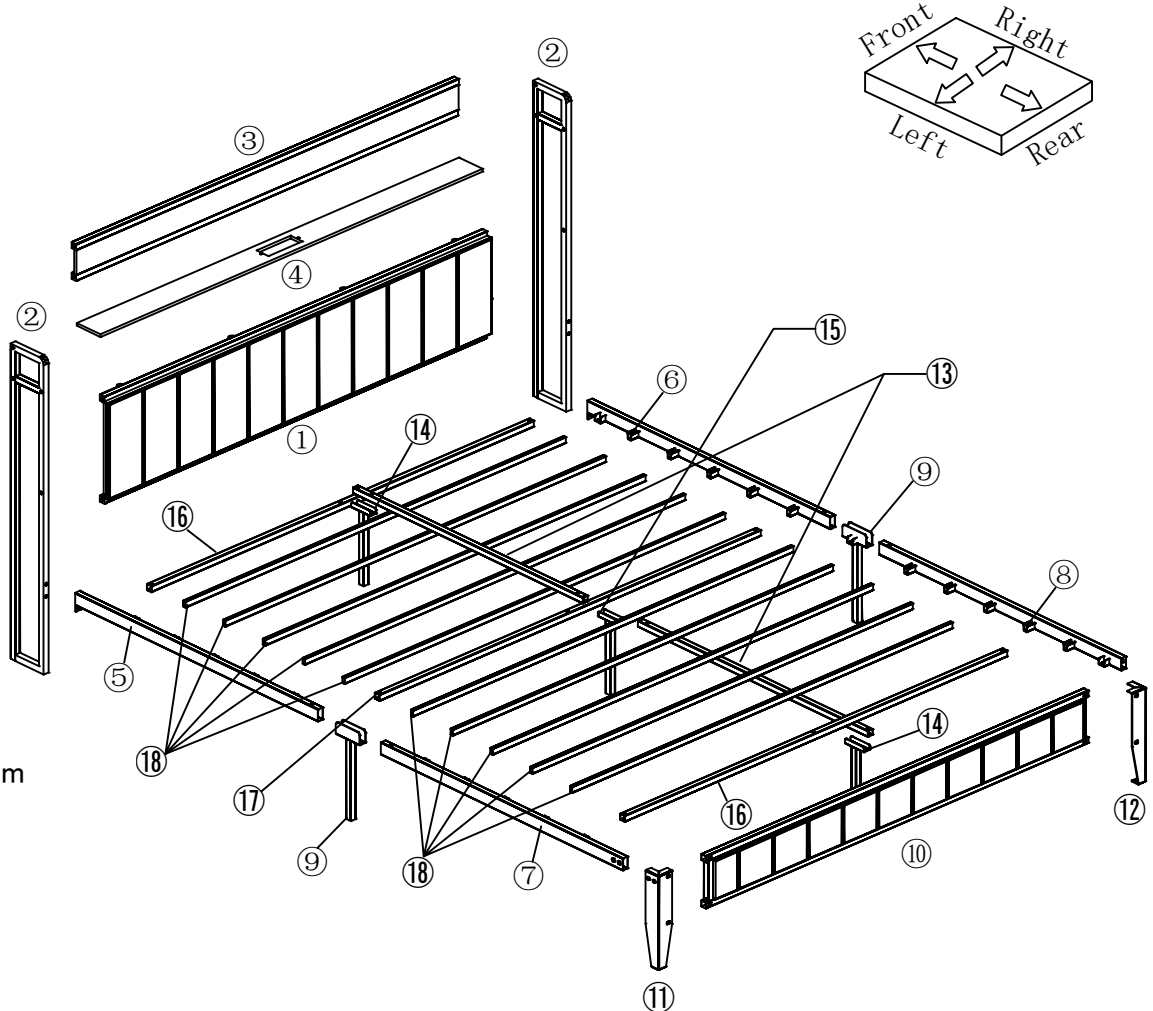

STEP 1

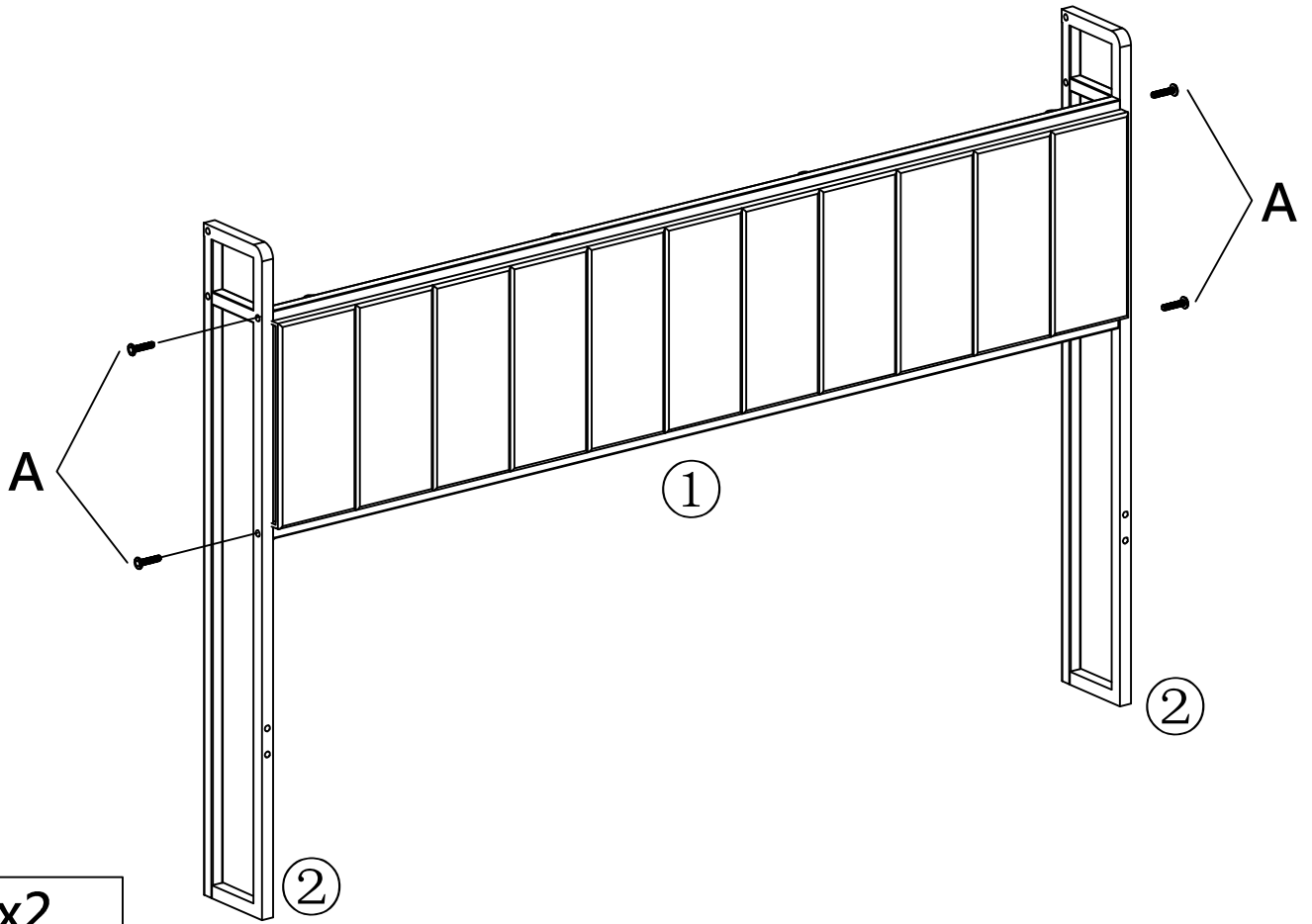

Ax2x2

STEP 2

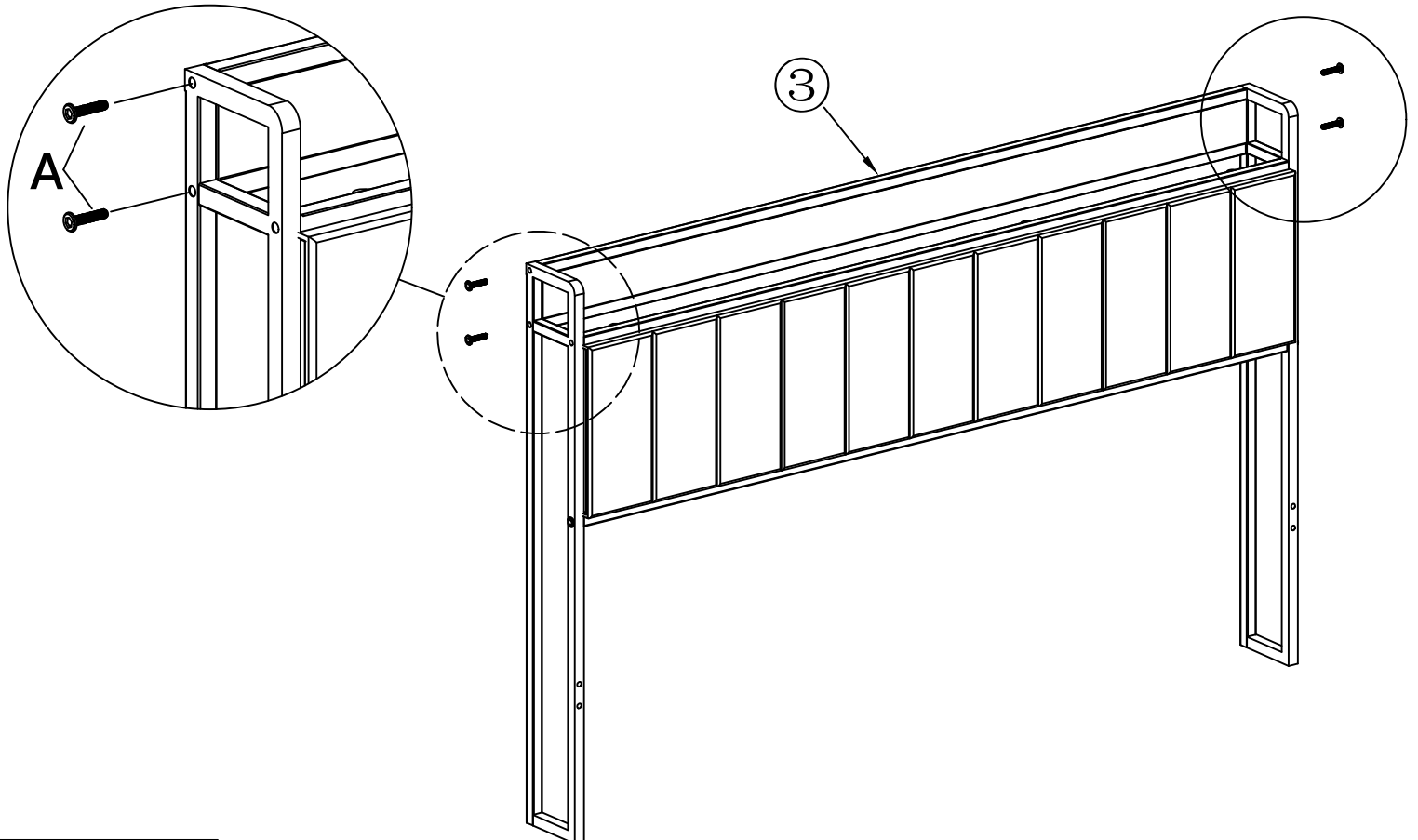

Ax2x2

STEP 3

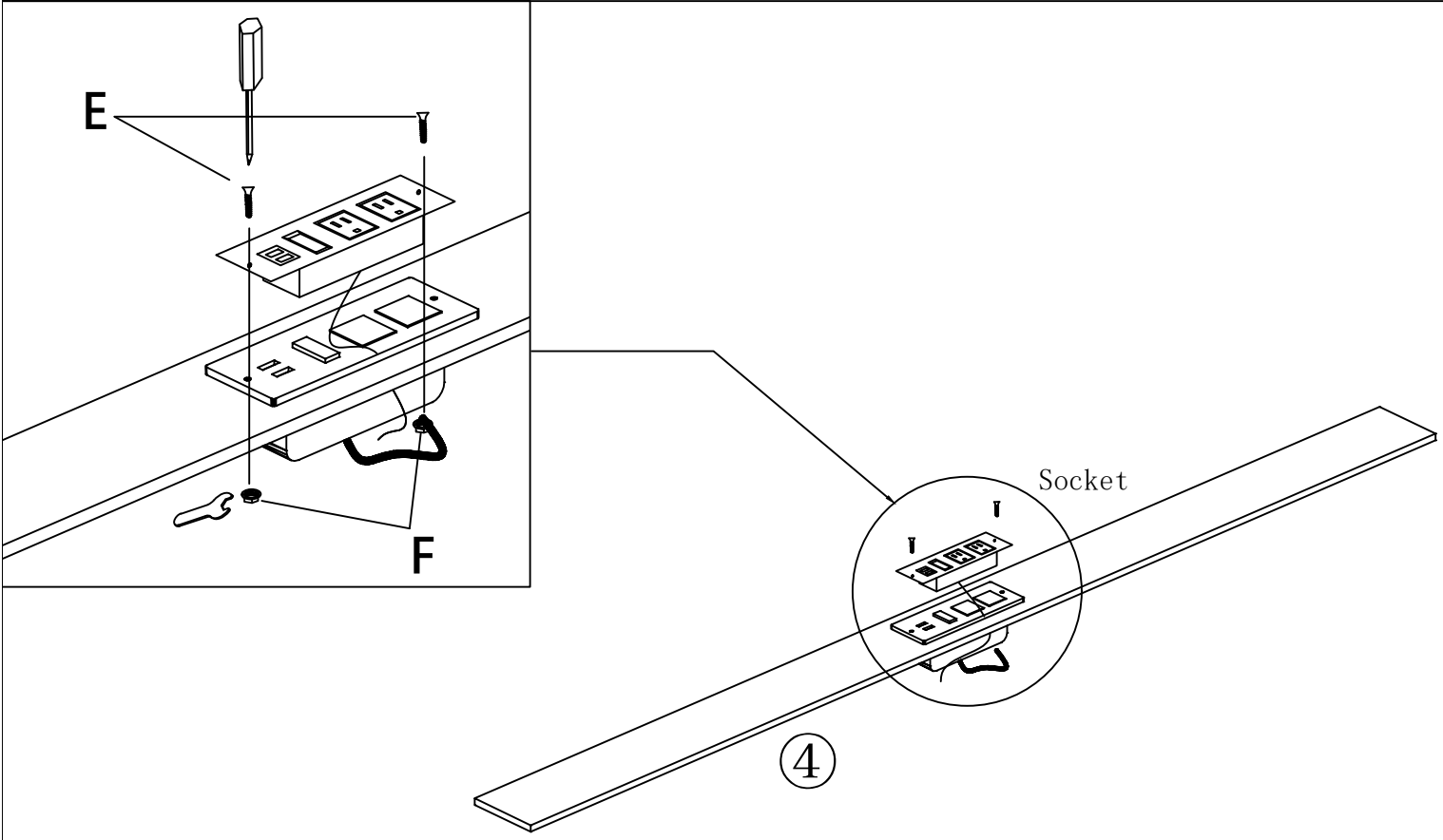

E*2, F*2

STEP 4

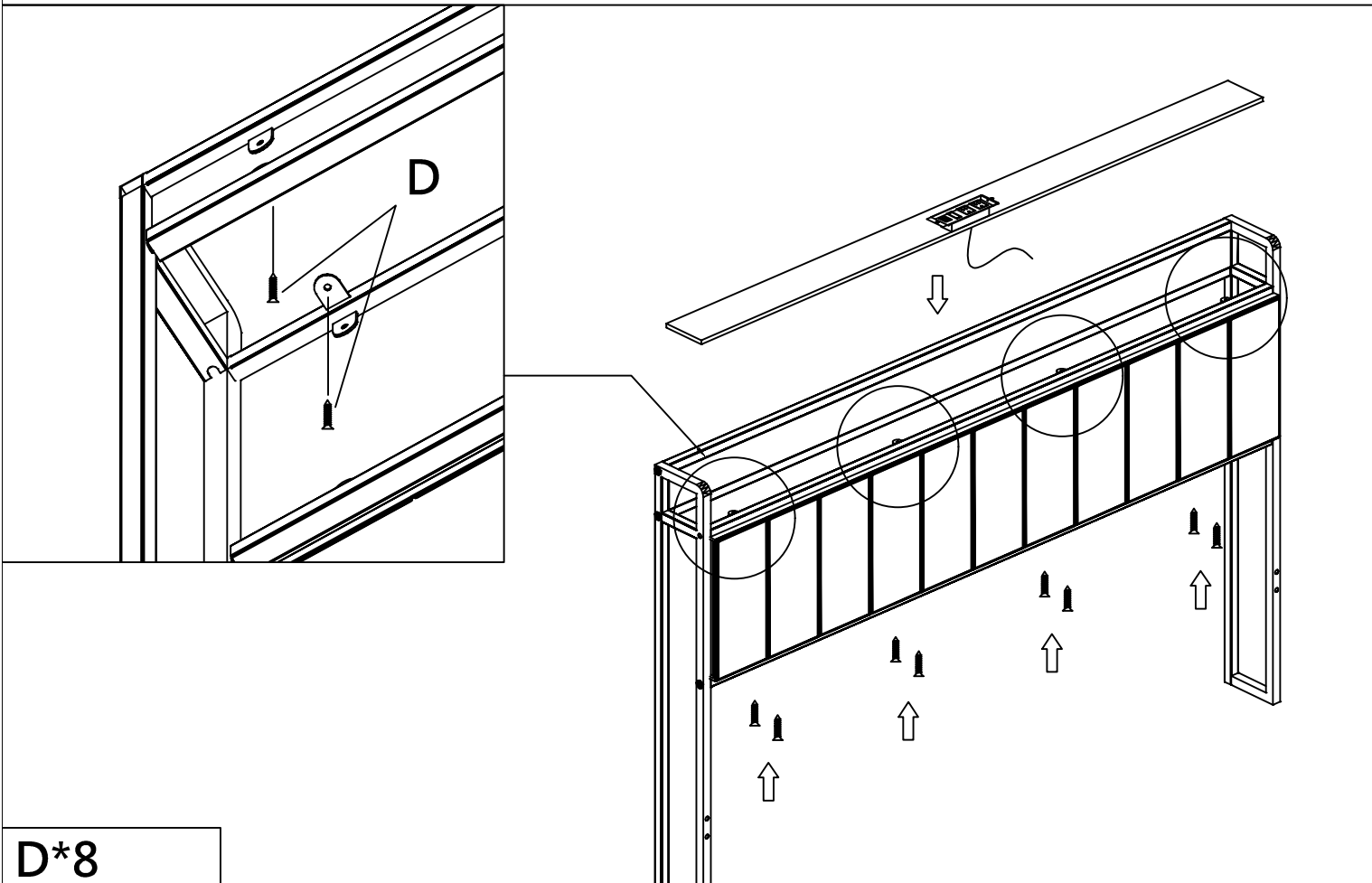

D*8

STEP 5

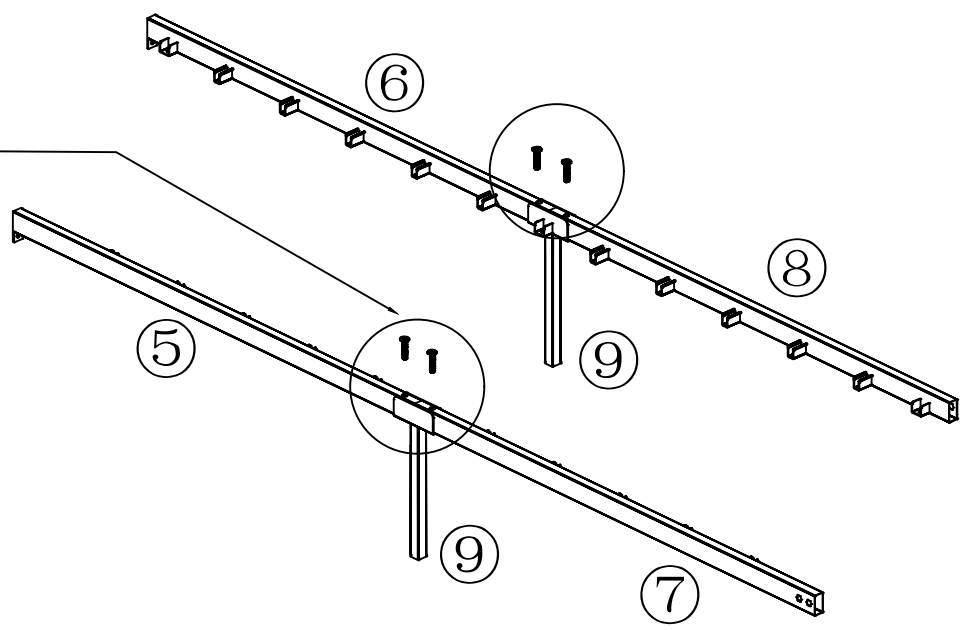
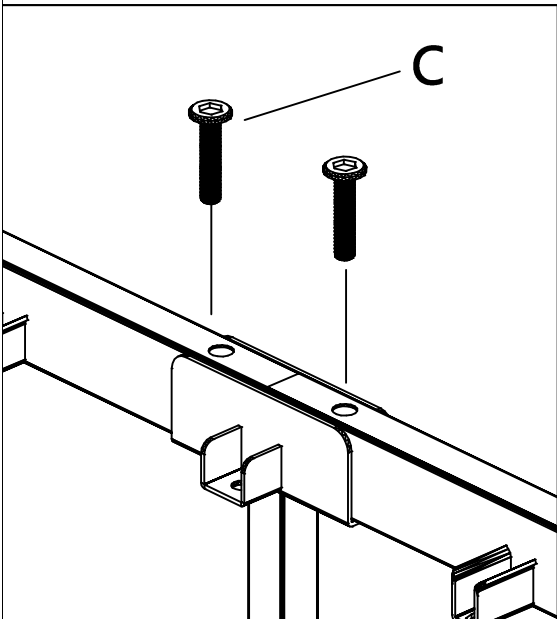

C*4

STEP 6

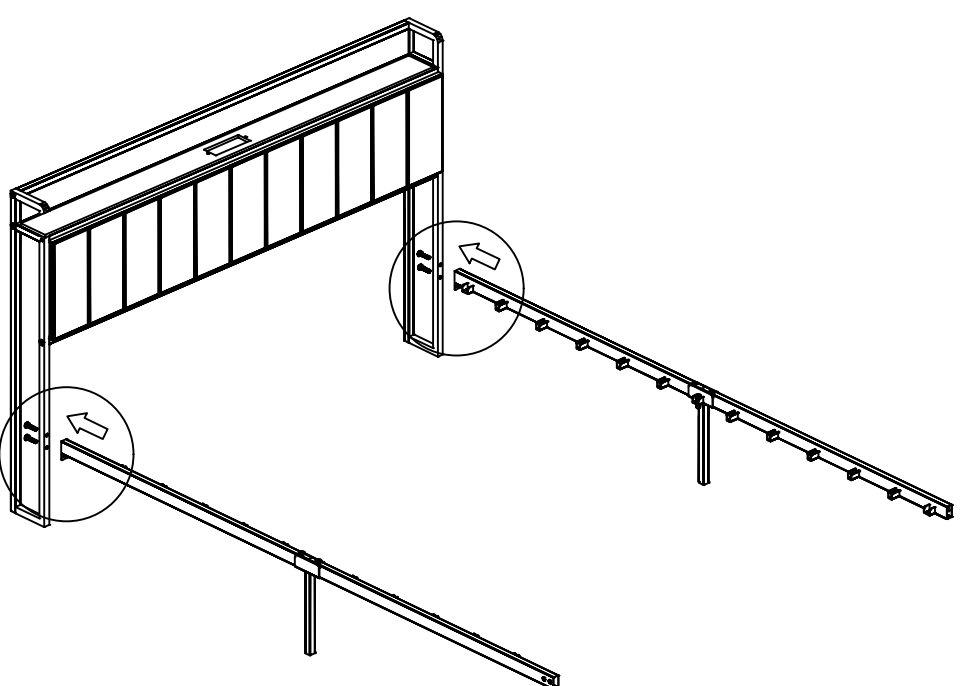
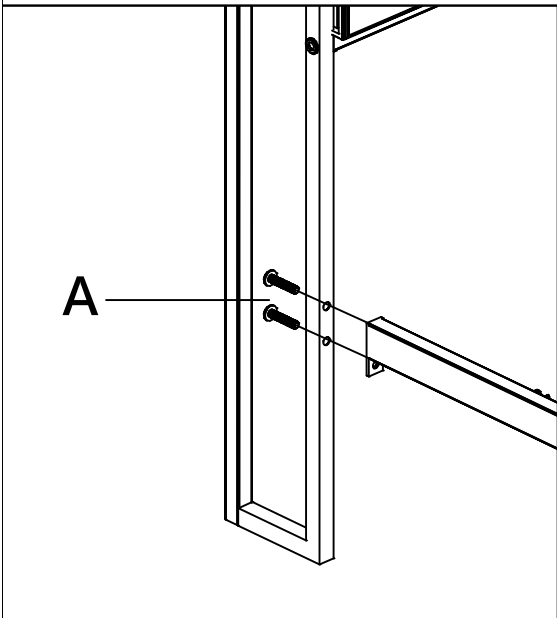

A*4

STEP 7

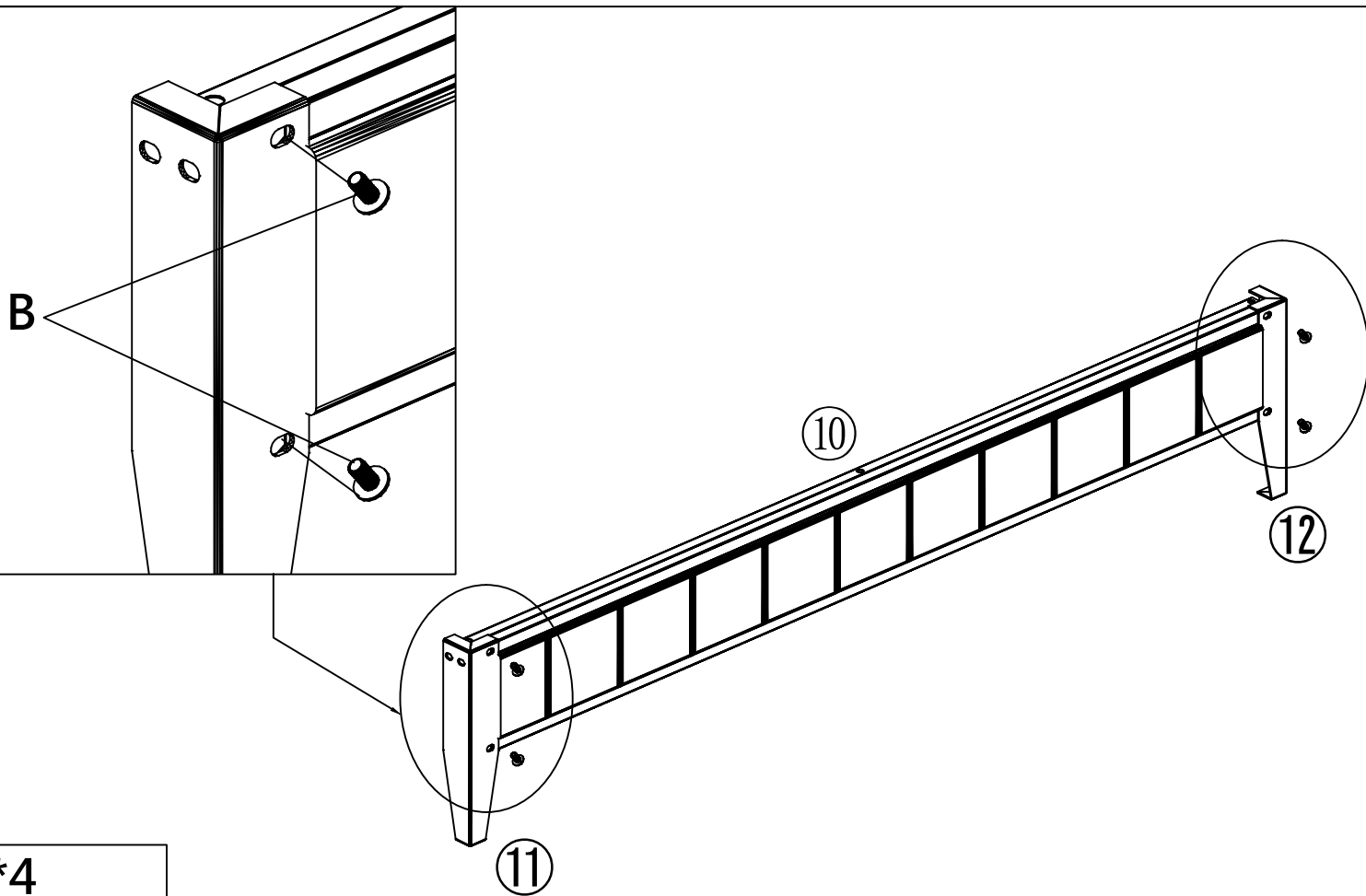

STEP 8

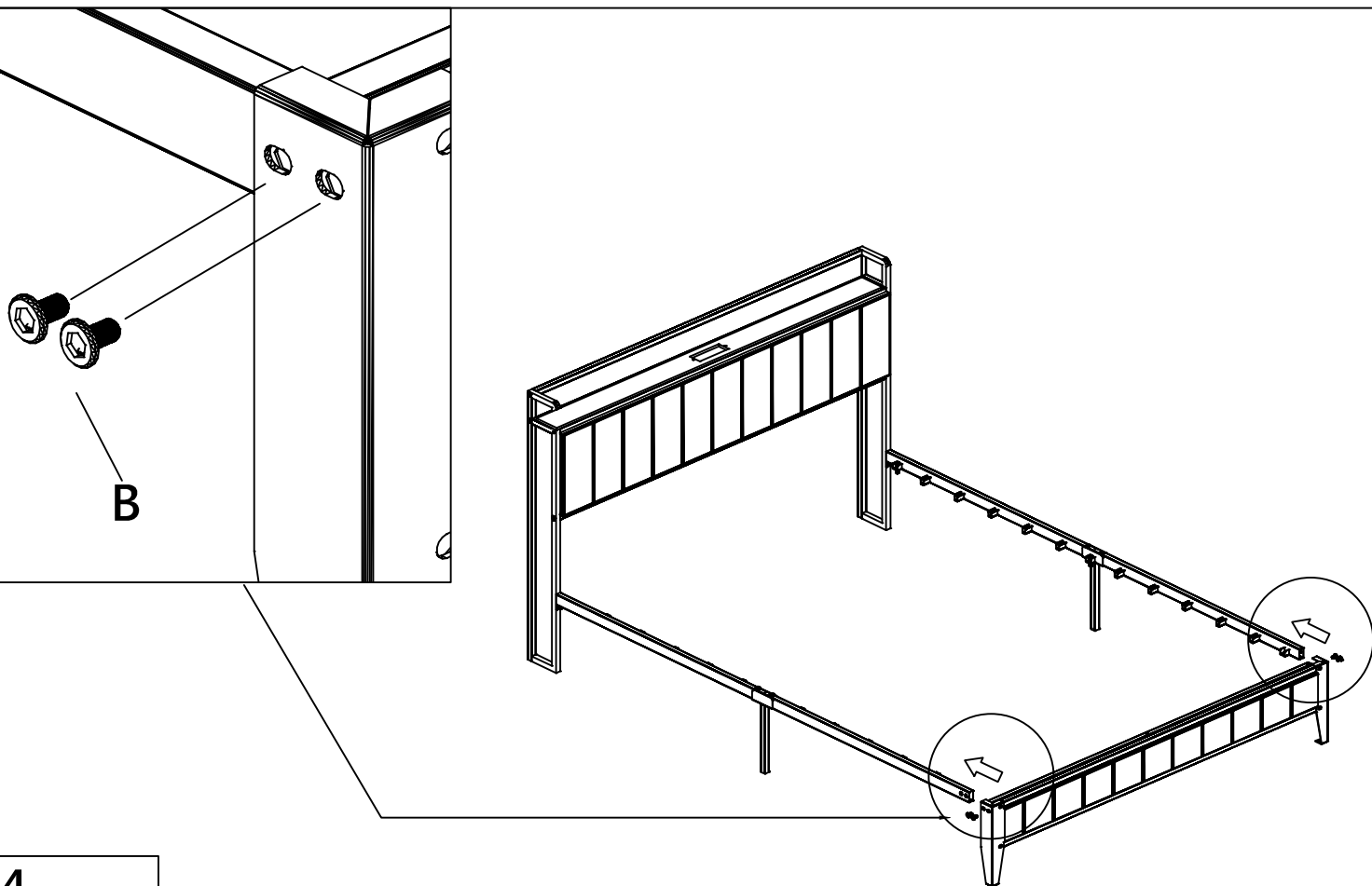

STEP 9

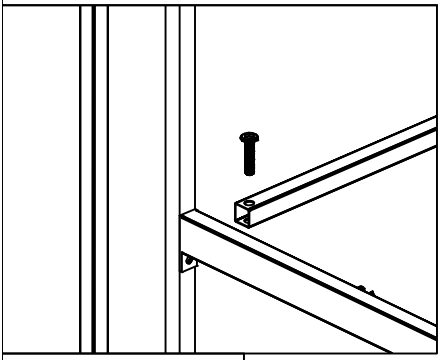

A*4

A*2

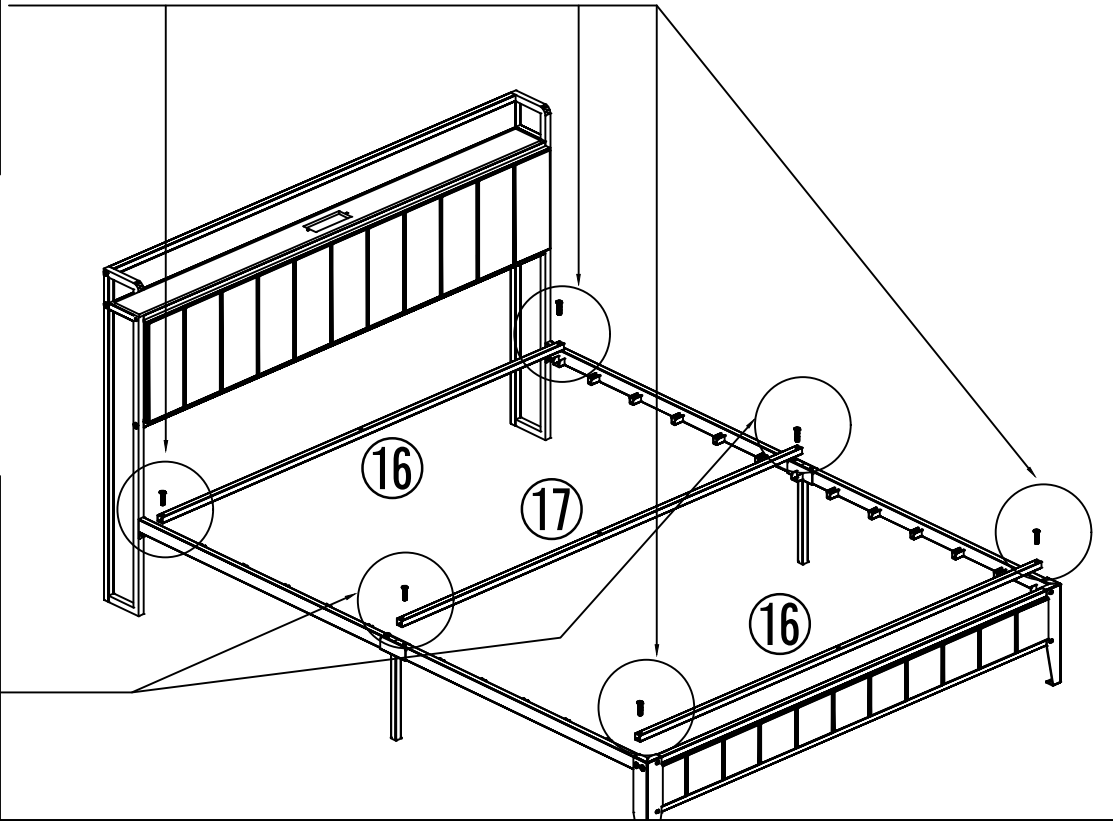
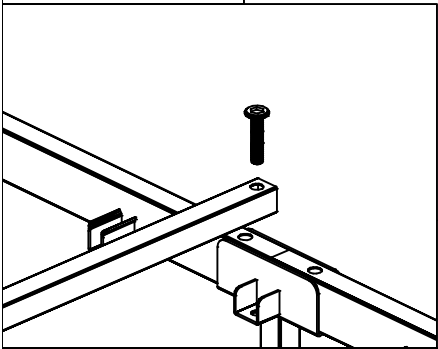

STEP 10

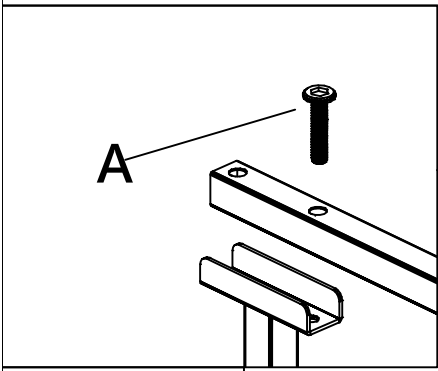

A

A*2

A*2

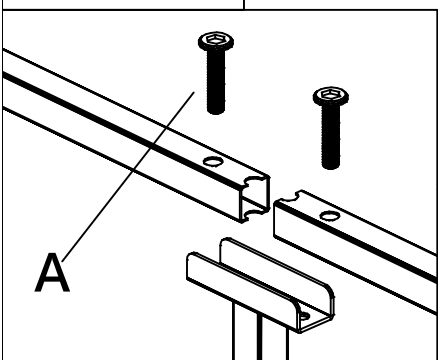

A

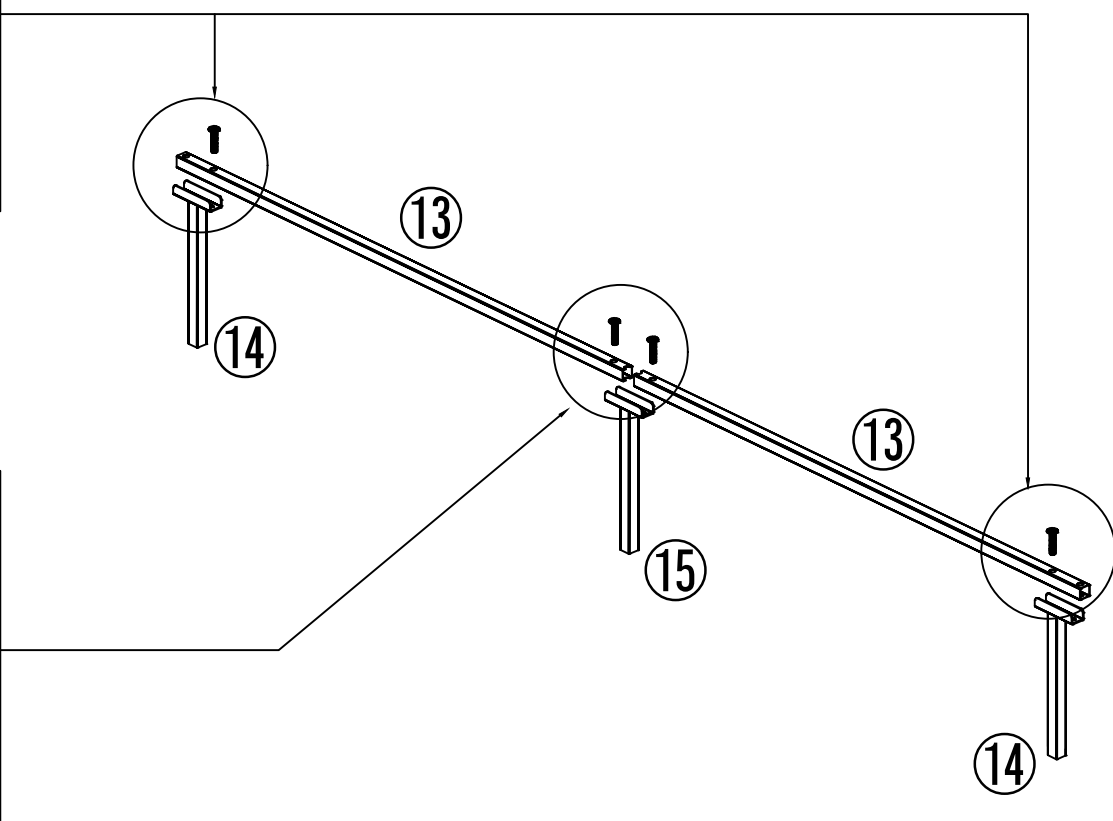

STEP 11

C*3

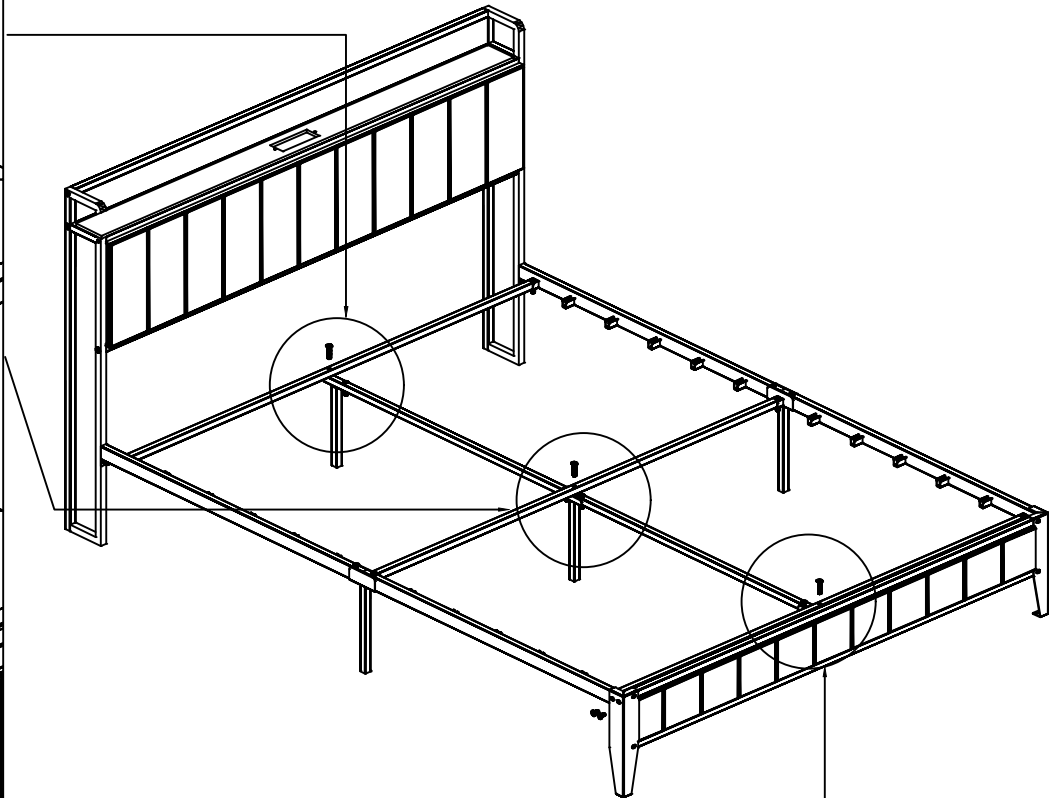

STEP 12

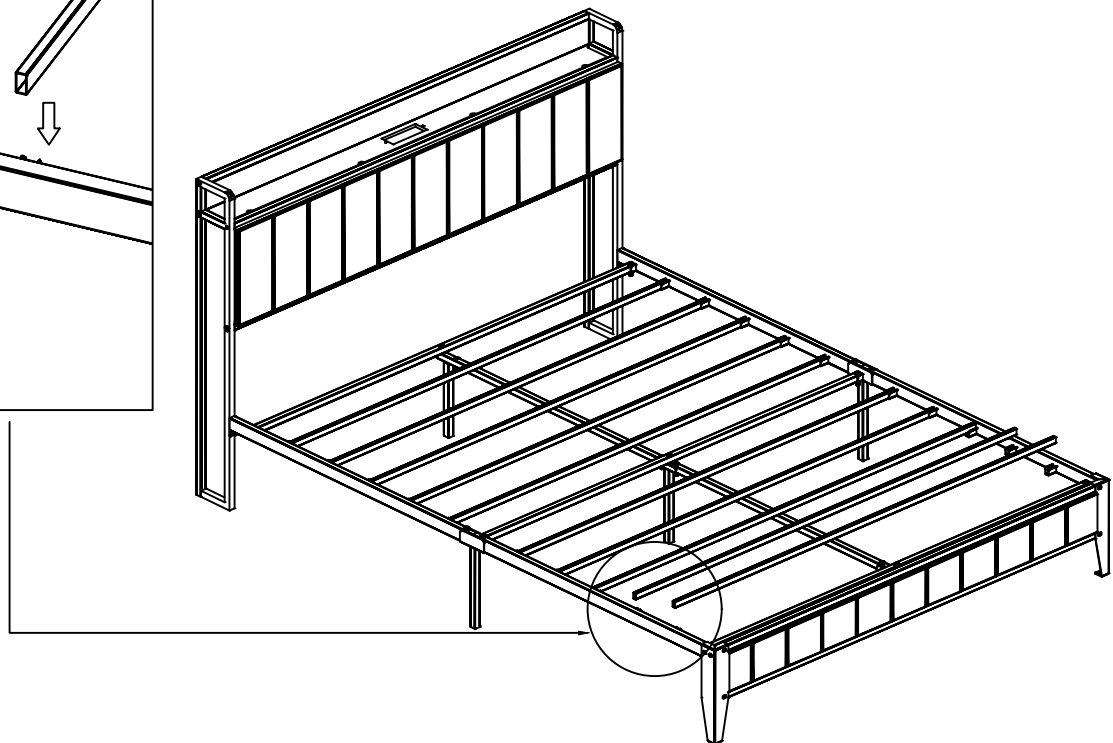
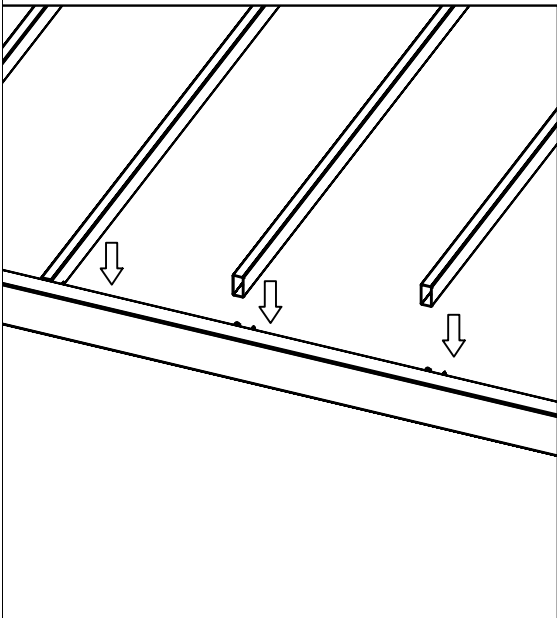

18*10

CAUTION: To reduce the risk of electric shock.

-Use only indoor in dry locations.

-Suitable for Household (Residential) use only.

ATTENTION: Pour réduire le risque de choc électrique.

-Utiliser uniquement à l'intérieur dans des endroits secs.

-Approprié à l'usage domestique (résidentiel) seulement.

This device complies with part 15 of the FCC Rules. Operation is subject to the following two conditions: 1) This device may not cause harmful interference. 2) This device must accept any interference received, including interference that may cause undesired operation.

