





# ASSEMBLY INSTRUCTIONS & PARTS IDENTIFICATION

## BACKLESS STOOL

Thank you for purchasing this quality product. Be sure to check all packing material carefully for small parts that may have come loose inside the carton during shipment.

Parts key			Hardware kit			
No	Qty	Description	No	Description		Qty
1	1 pc	Complete Seat	A	 Hex nut	M8	08 pcs
2	2 pcs	Right Facing Leg	B	 Lock washer	M8	08 pcs
3	2 pcs	Left Facing Leg	C	 Flat washer	M8 x 18	08 pcs
4	1 pc	Front Stretcher w/ Metal Trim	D	 Key Wrench	12	01 pc
5	1 pc	Back Stretcher	E	 Screw	Ø4 x 40	08 pcs
6	2 pcs	Small Side stretcher				
7	4 pcs	Floor Glide				

### STEP 1

- Carefully lay the Complete Seat (1) on a smooth flat surface to prevent scratches.
- Attach the legs of stool (2) and (3) to the appropriate positions. Using the Hex nuts (A), Lock washer (B) Flat washer (C).
- Do not fully tighten the nuts at this point. (See Detail A)

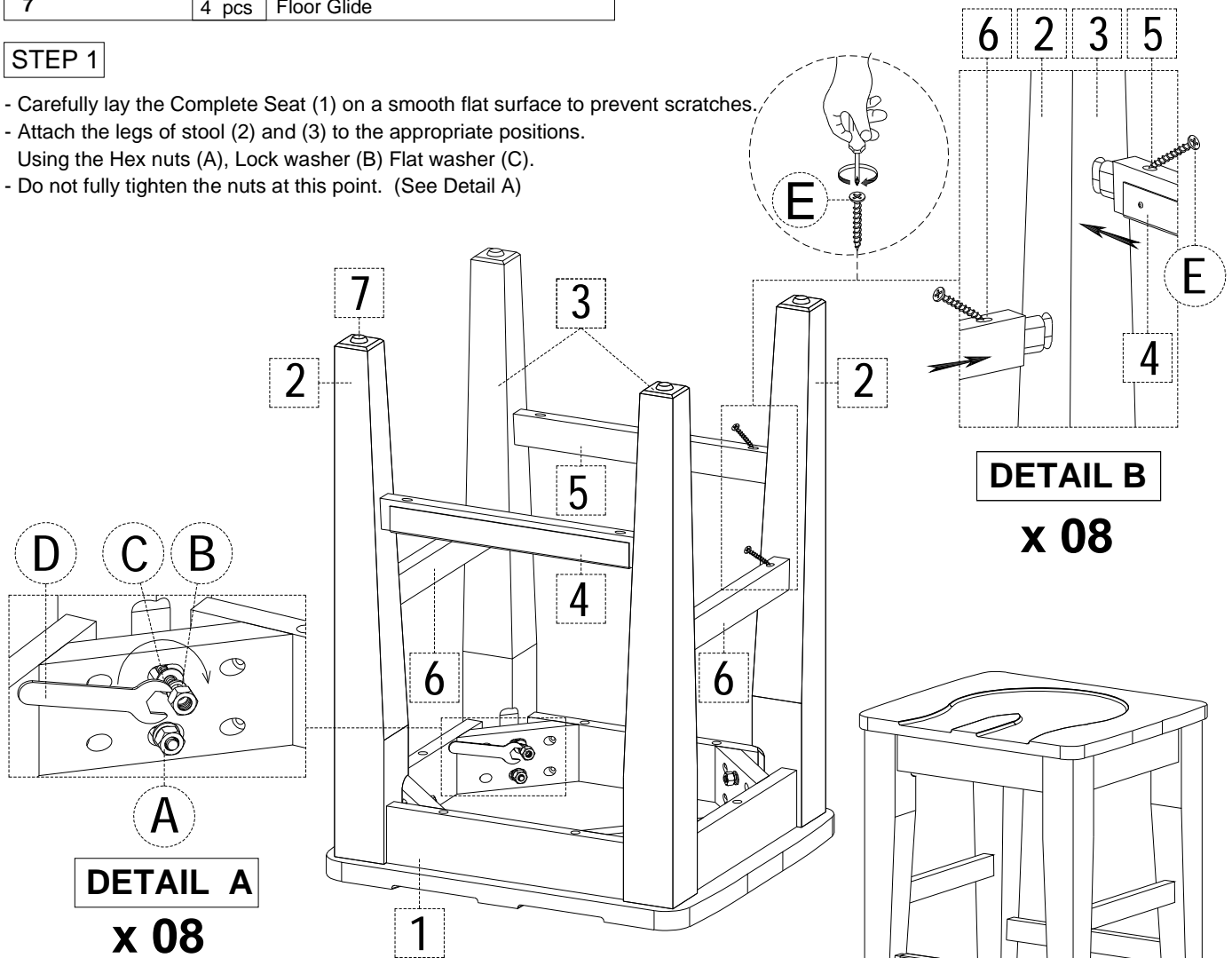

### STEP 2

- Attach the Front stretcher (4), Back stretcher (5) and Two Side stretchers (6) according to the illustration. Note the position of the seat top to determine the front and back. Use Screws (E) to attach the stretchers to the legs by using a Screwdriver (not provide). (See Detail B)
- Finally, tighten all the Hex nuts using the wrench provided before turning the chair over for use.

