









Assembly Instructions

Caution: You must read these Assembly Instructions before you proceed

Care & Maintenance

-  • Do not put hot items directly on furniture surface.
-  • Do not clean furniture with harsh cleansers or polish.
-  • To obtain the longest lifespan of your outdoor product minimizing exposure to direct sunlight is recommended.
-  • Children should not climb or jump on the furniture.
-  • Do not write on furniture without a padded barrier to protect the surface.
-  • To obtain the longest lifespan of your outdoor products, avoid extended and lengthy exposure to rain, snow, and direct sunshine. Whenever possible cover the product and /or place under patio or awnings.
-  • Not for commercial use. For residential use only.
-  • Stains may be removed with mild soap solution and damp cloth.
-  • Dust and pick-up spills using a clean, non-colored, lint- free cloth.

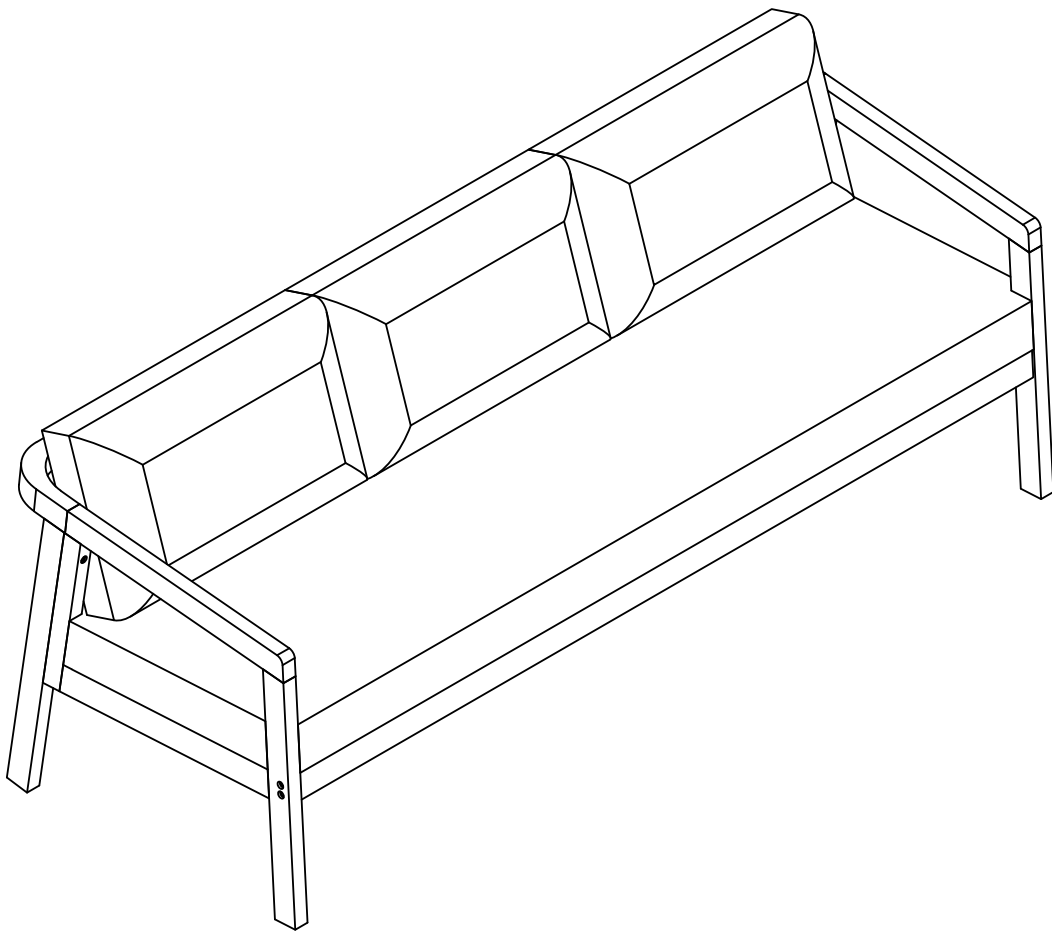

Please look in the Seat Panel for hardware packs.

BENCH 3 SEATER





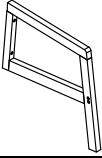
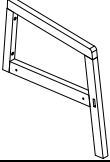
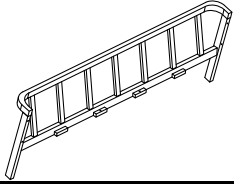
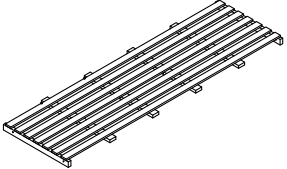
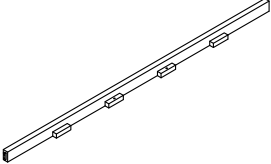

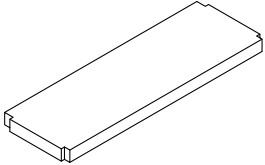
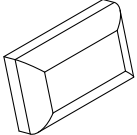
Caution: This Bench 3 Seater is NOT a TOY.
Keep your child / children at bay during the assembly process.
Whenever lifting or moving the Bench 3 Seater and to prevent any damage to it, two adults may be needed to execute these actions.

Part List

Label	Picture	Description	Qty
A		Left Arm Panel	1
B		Right Arm Panel	1
C		Backrest Panel	1
D		Seat Panel	1
E		Support Bar	1
F		Support Leg	2
G		Seat Cushion	1
H		Back Cushion	3

Hardware

No.	Picture	Description	Qty
①		Screw (M6x35mm)	9
②		Screw (M7x70mm)	5
③		Bolt (M6x40mm)	5
④		Bolt (M8x55mm)	5
⑤		Allen Wrench	1

Assembly Preparation

Before Beginning Assembly:

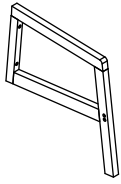

Ax1

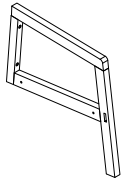

Bx1

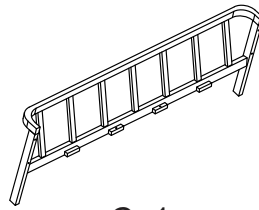

Cx1

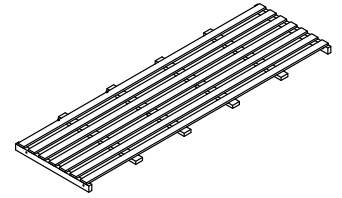

Dx1

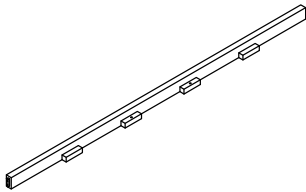

Ex1



Fx2

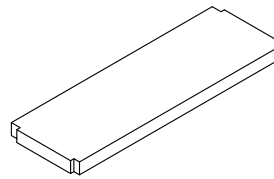

Gx1

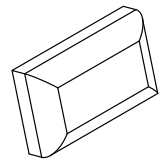

Hx3

- | | | |
|---|--|----|
| ① | | x9 |
| ② | | x5 |
| ③ | | x5 |
| ④ | | x5 |
| ⑤ | | x1 |



- Read instructions, cover to cover-



- Have 2 adults on hand for assembly-



- Do not assemble on flooring or carpet-



- Assemble on a clean non-marring surface (packing foam)-



- Save all packaging until finished-

Assembly Steps

Overview

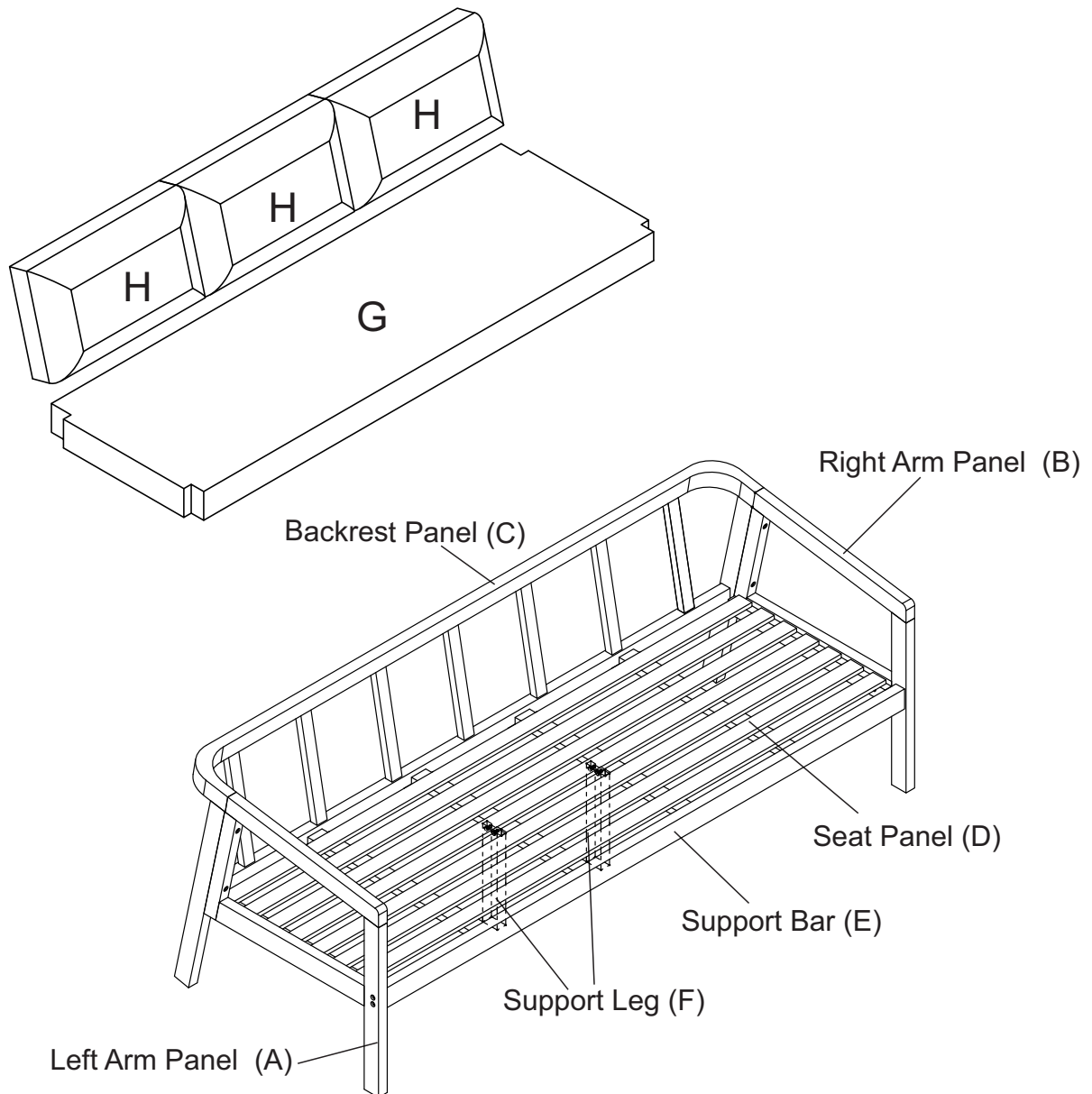

FRONT FACING

This Bench 3 Seater has multiple parts and may require up to some 30 minutes to assemble. To give you an overview of the Bench 3 Seater, the above picture to assemble to help you put the various parts into perspective. Please read through the instructions here below to familiarise the parts and steps before assembly.

Step 1

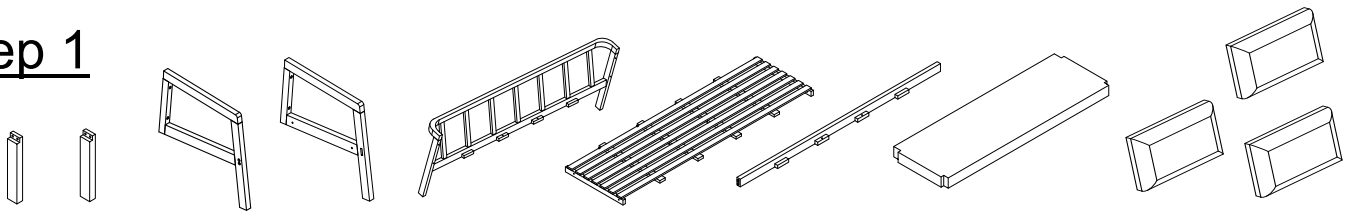

Unpack and place all parts on a clean, non-marring surface.

Step 2

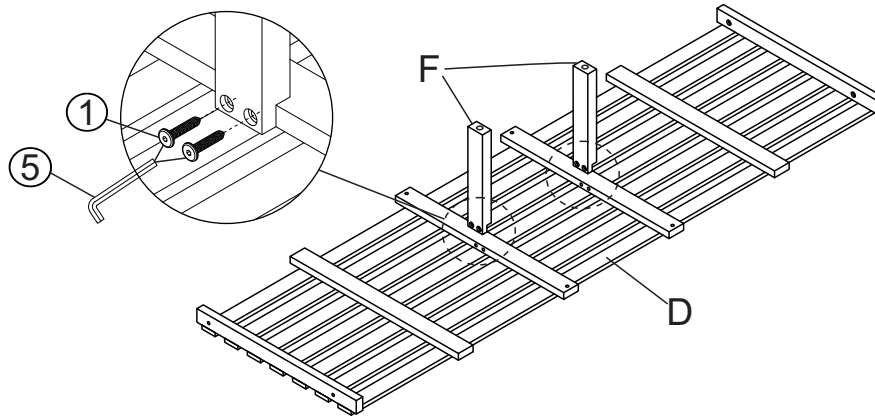

Turn the Seat Panel (D) (bottom-side up) and place it on a clean, soft surface to avoid any scratches or damage to the product.

2. Attach Support Leg (F) to the Seat Panel (D) using Screw (1) with Allen Wrench (5).

Do not fully tighten the Screws.

Step 3

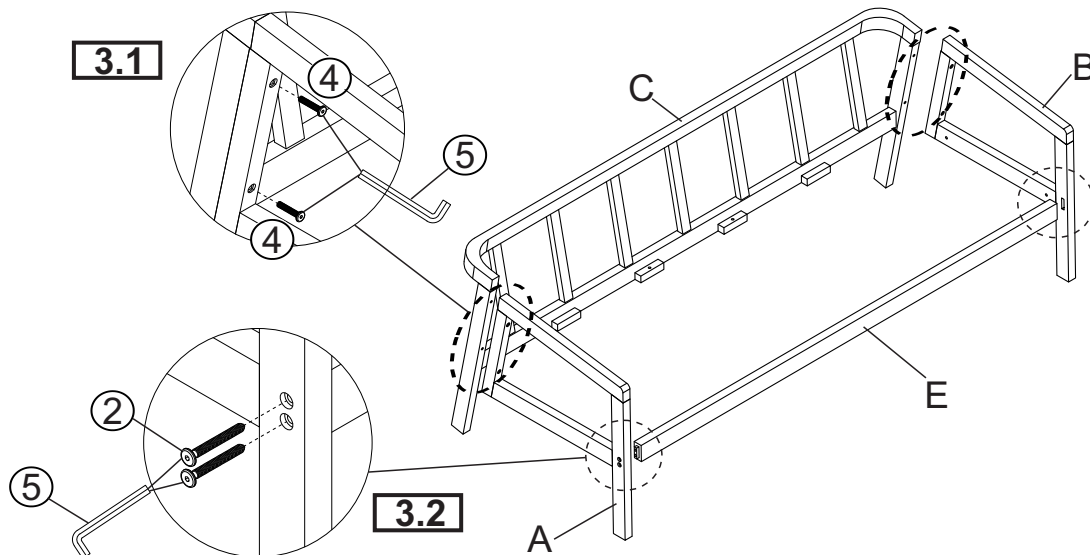

Place the Left Arm Panel (A) and Right Arm Panel (B) upright as shown in the picture above onto a clean, soft surface to avoid any scratches or damage to the product.

3.1: Attach Backrest Panel (C) to the Left Arm Panel (A) and Right Arm Panel (B) using Bolt (4) with Allen Wrench (5).

3.2: Attach Left Arm Panel (A) and Right Arm Panel (B) to the Support Bar (E) using Screw (2) with Allen Wrench (5).

Do not fully tighten the Screws and Bolts.

Step 4

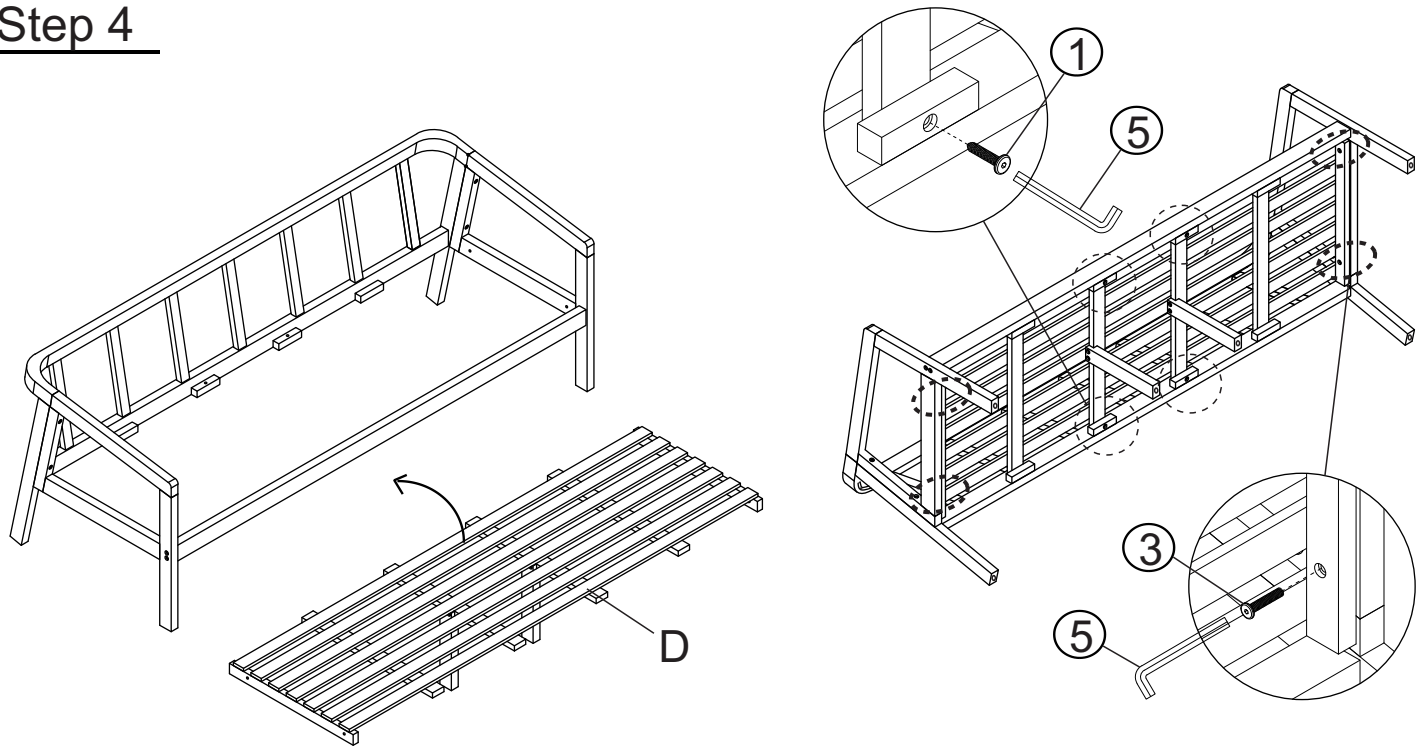

4. Place Seat Panel (D) onto the Bench 3 Seater using Bolt (③) and screw (①) with Allen wrench (⑤).

Do not fully tighten the Screws and Bolts.

Step 5

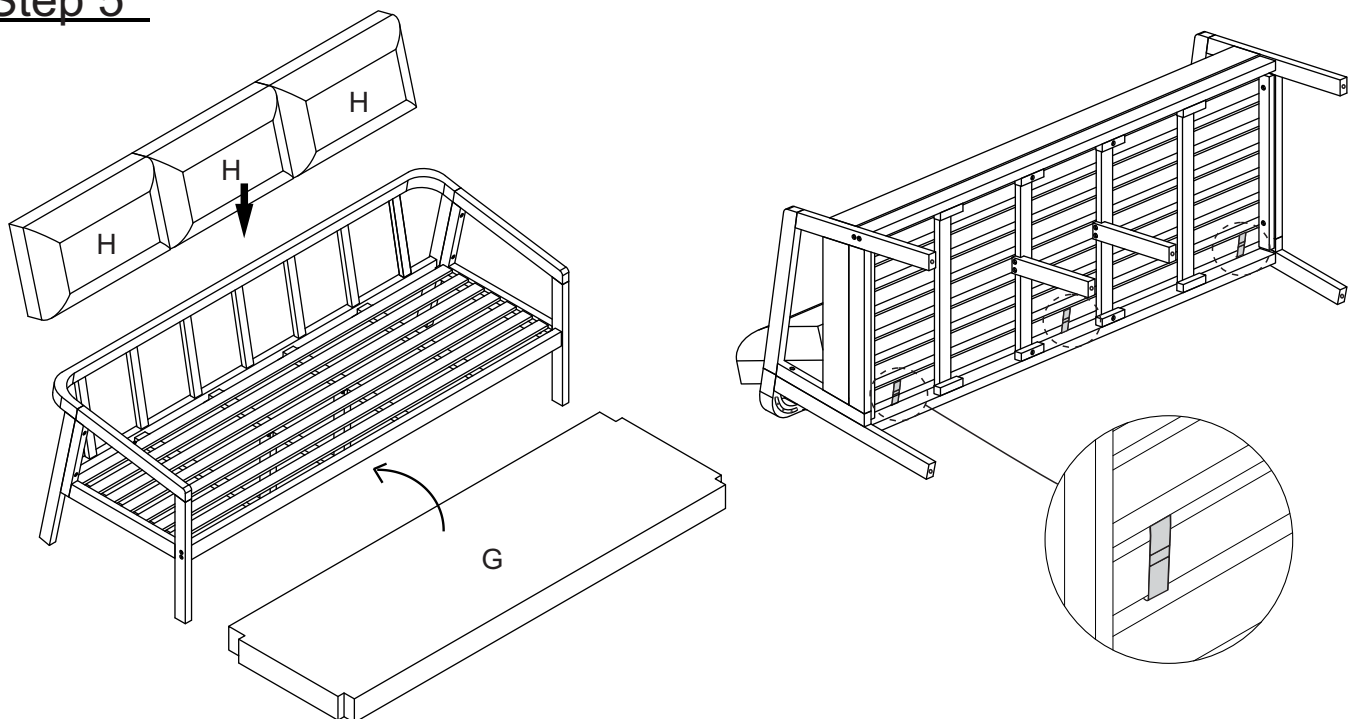

5. Place Seat Cushion (G) and Back Cushion (H) onto the Bench 3 Seater and affix the magic tape straps around the Bench 3 Seater as shown above.

This Bench 3 Seater can only be used on a flat, level surface.

Step 6

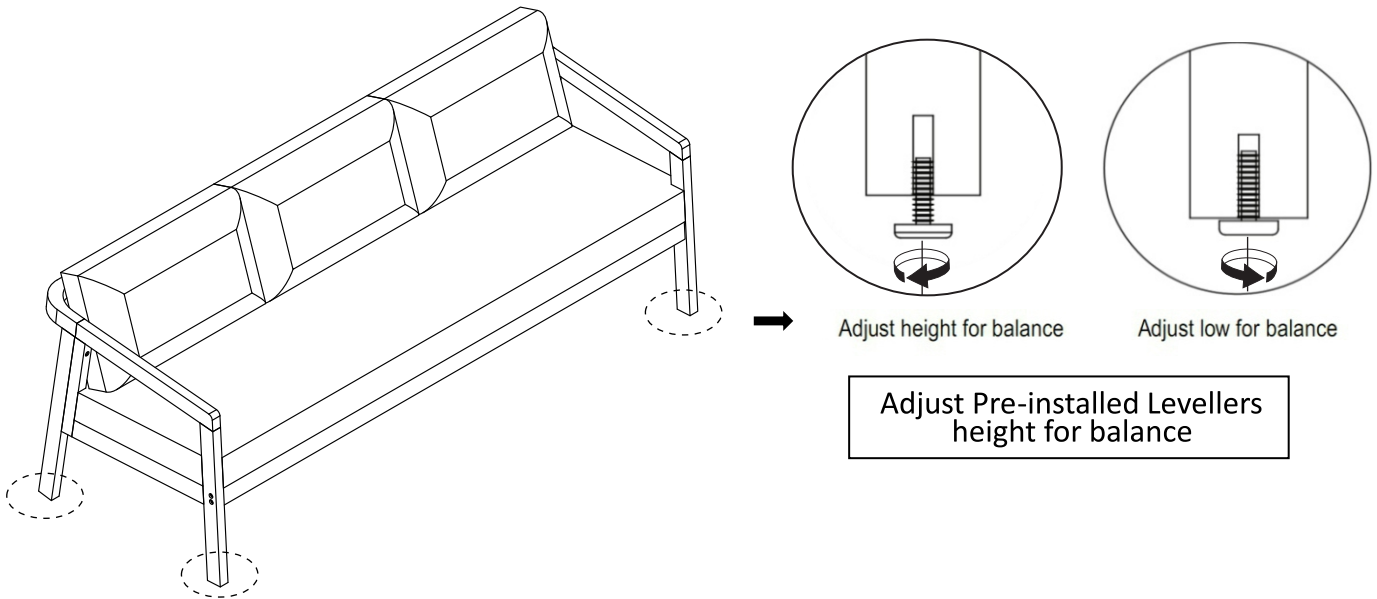

Inspect the Bench 3 Seater and make sure all parts are adequately connected.

Then EXERT pressure, floorwards onto the Bench 3 Seater with both hand

This pressure will help align all parts at all joints.

In a sequential manner, tighten all Bolts and Screws at all joints.

Adjust the Levellers until the Bench 3 Seater is level with the ground.

To adjust the Levellers, get assistance from an adult partner to lift/lean and hold the Bench 3 Seater while you are working.

CAUTION : When tightening these screws and bolts, tighten sequentially.

DO NOT tighten any screw or bolt fully and then move towards the next one. This could cause the frame to warp.

WARNING!! IF THE BENCH 3 SEATER IS NOT STABLE , IT COULD LEAD TO DAMAGING THE PRODUCT.

Step 7

