

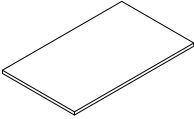

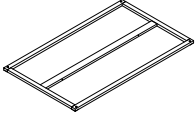

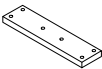
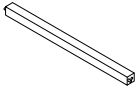
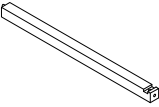
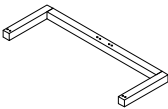

# ASSEMBLY INSTRUCTION

## COUNTER HEIGHT TABLE

<b>A</b> Table Top 	<b>B</b> Apron Frame 	<b>C</b> Joint Panel 	<b>D</b> Side Post 
1 pc	1 pc	2 pcs	4 pcs
<b>E</b> Middle Post 	<b>F</b> Foot Frame 	<b>G</b> Bolt 1/4" x 2" 	<b>H</b> Bolt 1/4" x 1-1/2" 
4 pcs	2 pcs	12 pcs	16 pcs
<b>I</b> Lock Washer 1/4" x 1/2" 	<b>J</b> Flat Washer 1/4" x 3/4" 	<b>K</b> Allen Wrench 1/6" 	<b>L</b> Plastic Button 3/5" x 1/5" 
24 pcs	24 pcs	1 pc	4 pcs

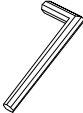

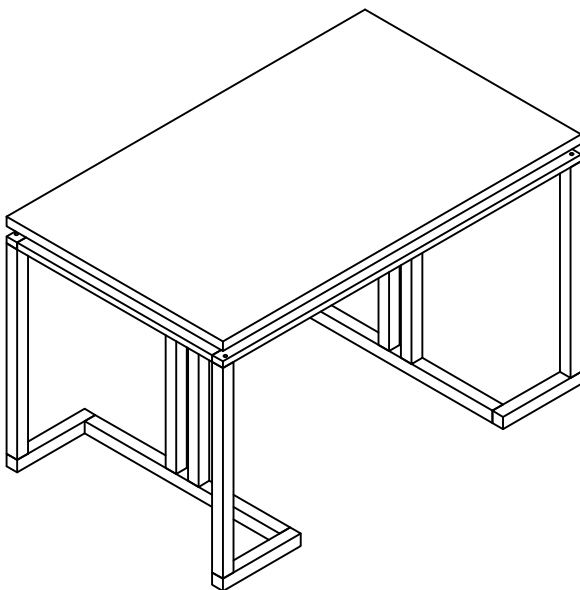
This page lists all the contents included in the box. Please take the time to identify the hardware as well as the individual components to this product. As you unpack and prepare for assembly, place the contents on a carpeted or padded area to protect them from damage.

**1**

Attach the Side Post (D) and Middle Post (E) to Foot Frame (F) by Bolt (G), Lock Washer (I) and Flat Washer (J) with Allen Wrench (K) as shown.

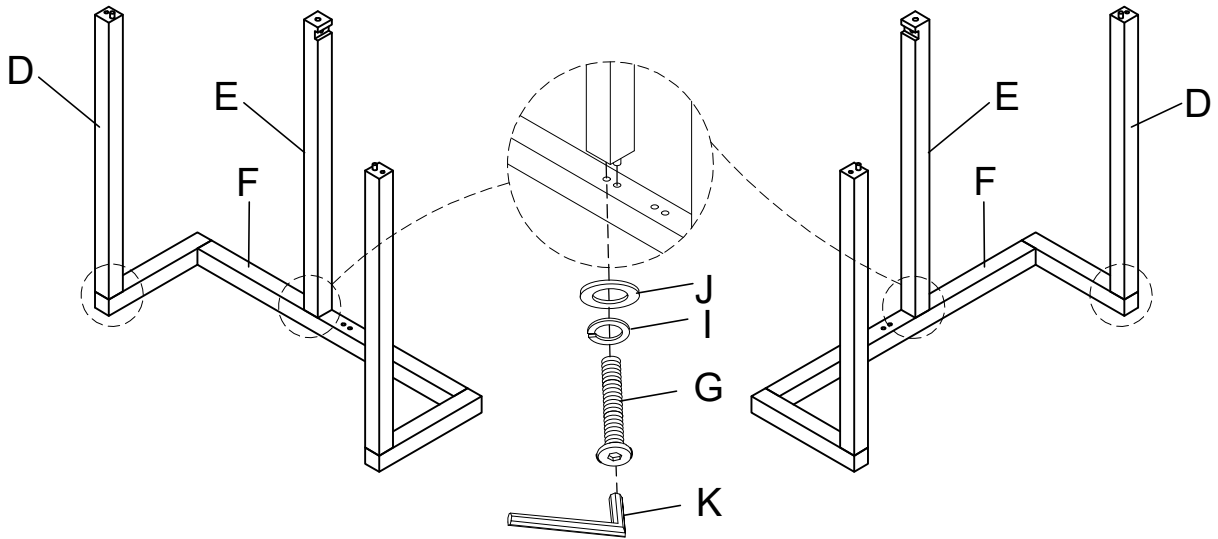
**2**

Attach Apron Frame (B) to Side Post (D) by Bolt (H) with Allen Wrench (K) and cover the Bolt (H) by Plastic Button (L). Attach the other 2 Middle Post (E) to Foot Frame (F). Then attach the Middle Post (E) to Apron Frame (B) by Bolt (G), Lock Washer (I) and Flat Washer (J) with Allen Wrench (K) as shown.

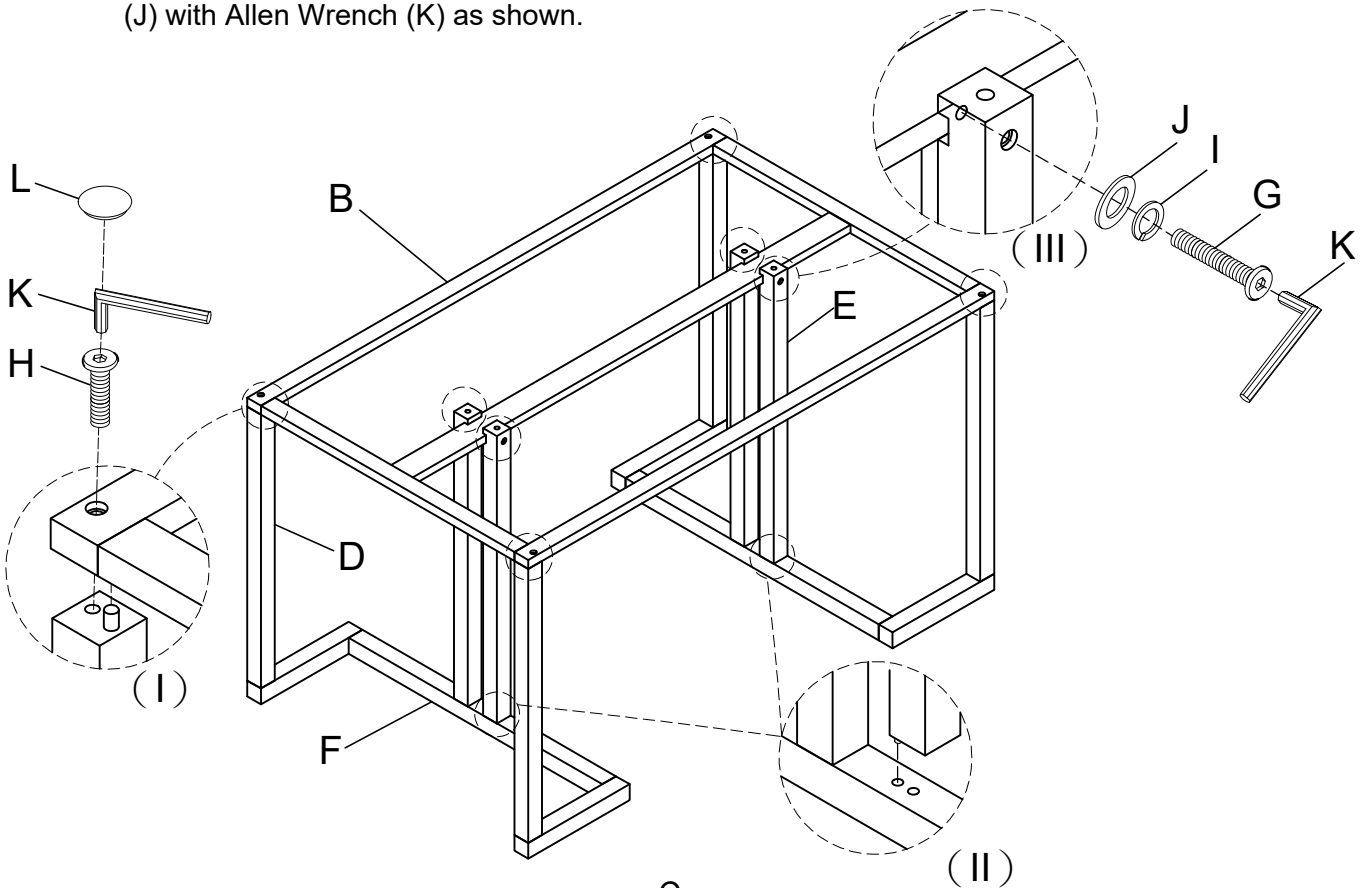

**3**

Attach the Joint Panel (C) to Middle Post (E) by Bolt (H), Lock Washer (I) and Flat Washer (J) with Allen Wrench (K) as shown.

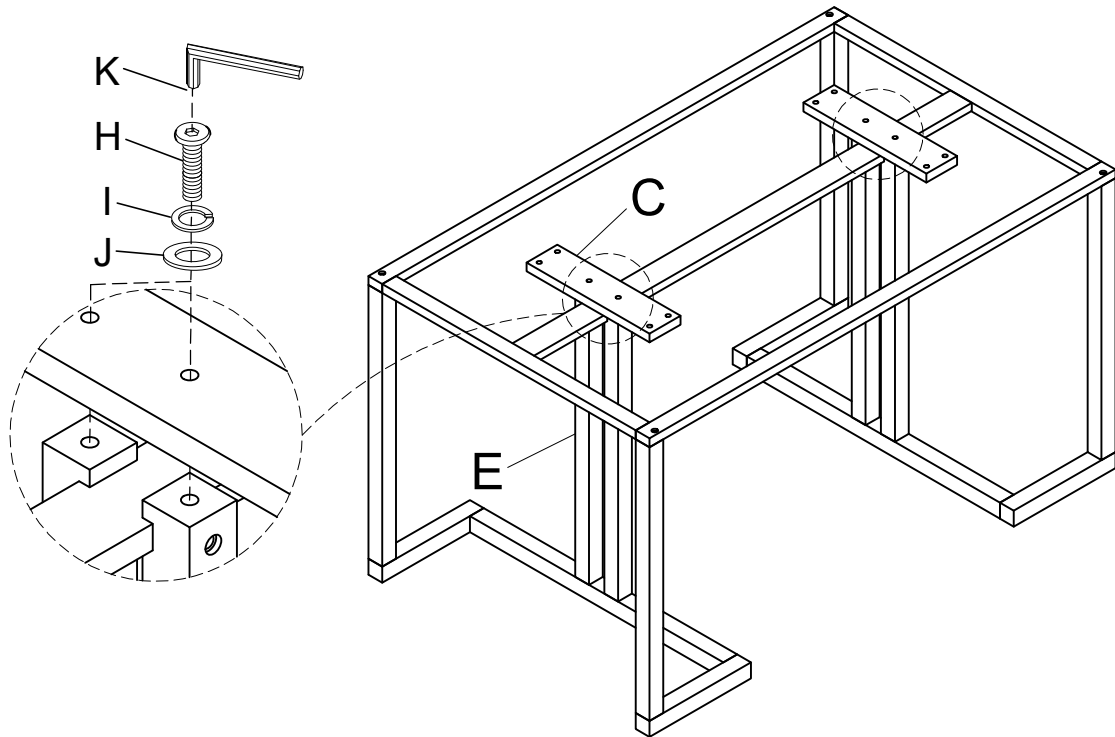
**4**

Turn the assembly over. Attach the Middle Post (E) to Foot Frame (F) by Bolt (G), Lock Washer (I) and Flat Washer (J) with Allen Wrench (K) as shown.

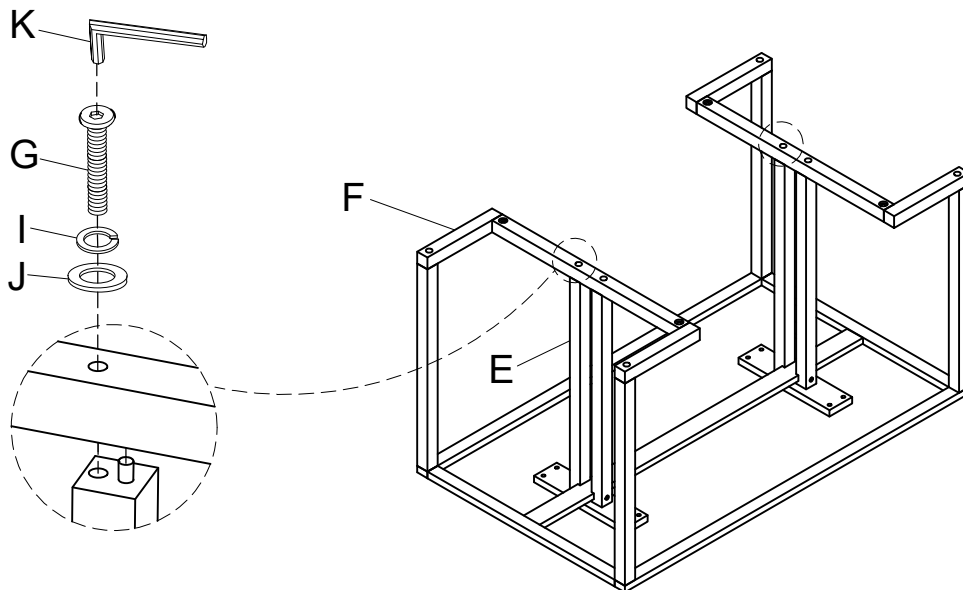

**5**

Place the Table Top (A) on a smooth carpeted surface. Tighten the Joint Panel (C) on the Table Top (A) by Bolt (H), Lock Washer (I) and Flat Washer (J) with Allen Wrench (K) as shown.

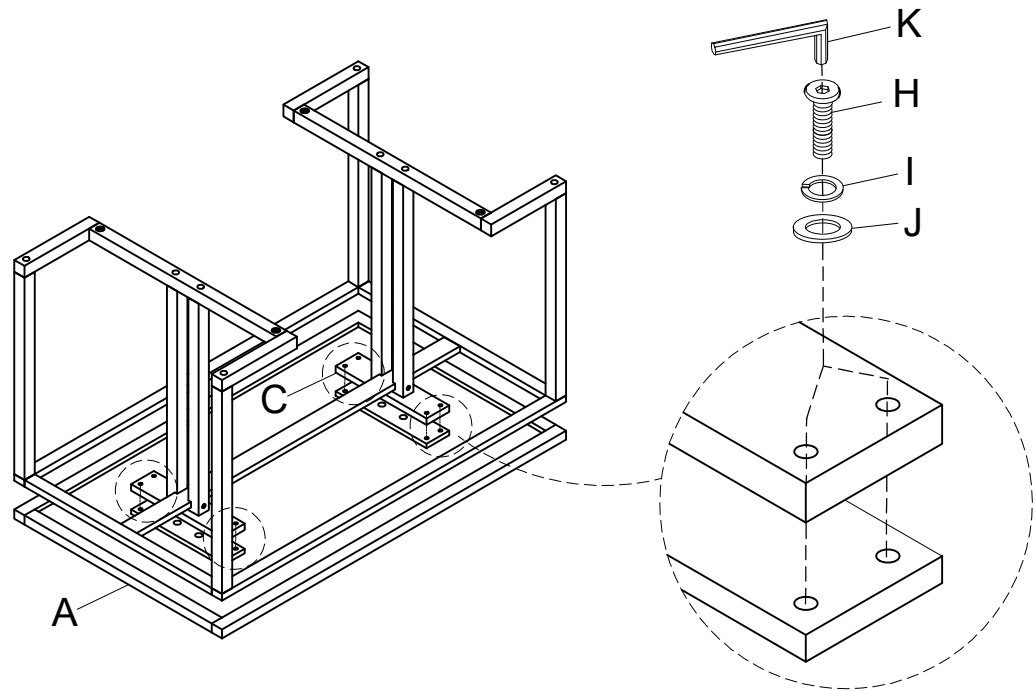







---

**Cleaning & Care**

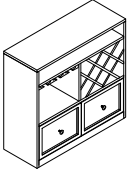
Treat surface with care. Surface is resistant to scratches but is not scratch resistant. Clean surfaces with a dry or damp soft cloth. Do not use abrasive cleaners. Hardware may loosen over time. Periodically check that all connections are tight.

# ASSEMBLY INSTRUCTION

## CABINET WITH WINE RACK

<b>A</b> Cabinet  1 pc	<b>B</b> Caster  4 pcs	<b>C</b> Screw 1/2"  16 pcs	<b>D</b> Strap 5 × 300mm (Anti-Tipping Kit)  1 pc
<b>E</b> Bracket 1.5 × 16 × 26.7mm (Anti-Tipping Kit)  2 pcs	<b>F</b> Screw 5/8" (Anti-Tipping Kit)  1 pc	<b>G</b> Screw 2" (Anti-Tipping Kit)  1 pc	

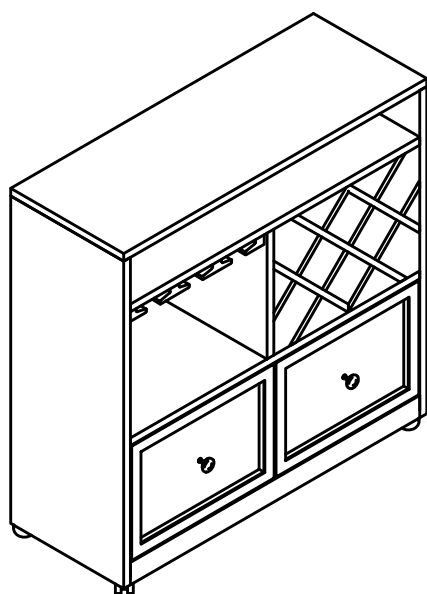

This page lists all the contents included in the box. Please take the time to identify the hardware as well as the individual components to this product. As you unpack and prepare for assembly, place the contents on a carpeted or padded area to protect them from damage.

**1**

Attach the Caster (B) to the Cabinet (A) using Screw (C) with a Phillihps Head Screwdriver (not provided) as shown.

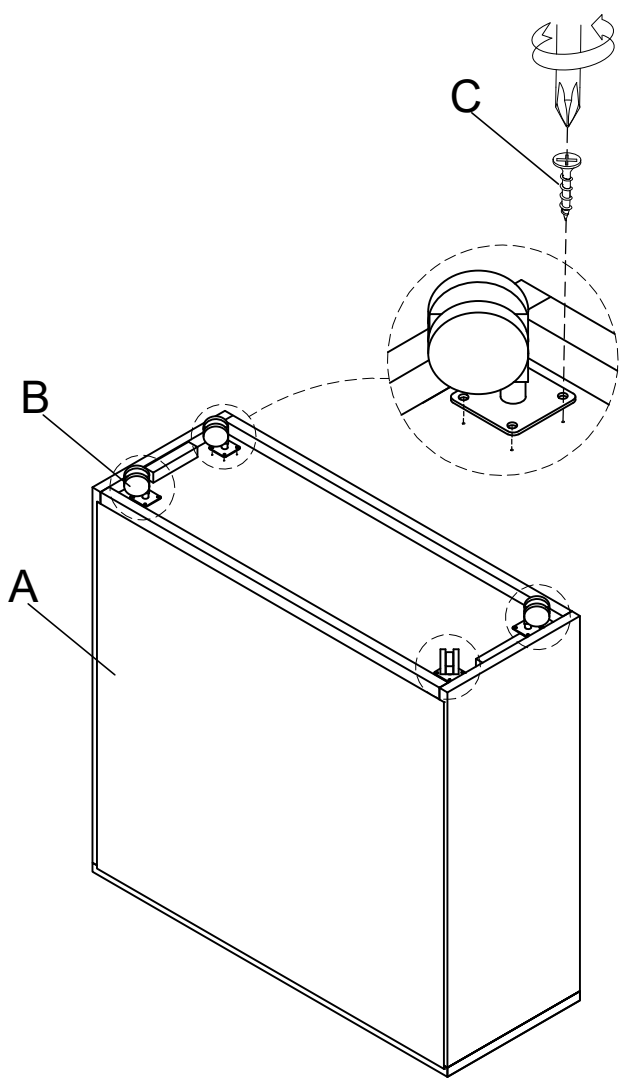

---

**2****(OPTIONAL)**

This Anti-Tipping Kit restraint must be attached to a wall.

- i. Attach one Bracket (E) to the cabinet back using Screw (F) through the small hole.
- ii. Install the other Bracket (E) on the wall using the Screw (G) through the small hole 2" below the Bracket on the cabinet.
- iii. Move the cabinet to the position and both Bracket (E) are vertically in line.
- iv. Thread the Strap (D) through the large hole of Bracket (E) and pull it tight.

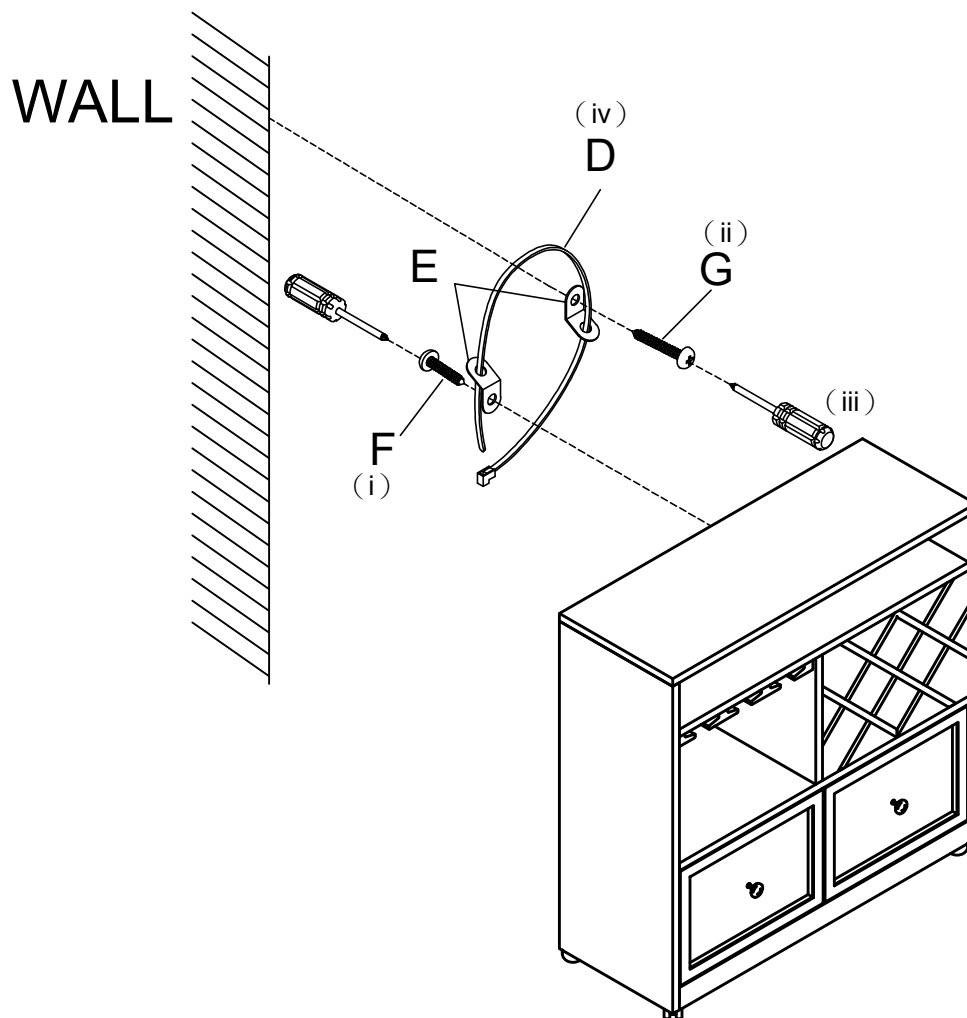

---

**Cleaning & Care**

Treat surface with care. Surface is resistant to scratches but is not scratch resistant. Clean surfaces with a dry or damp soft cloth. Do not use abrasive cleaners. Hardware may loosen over time. Periodically check that all connections are tight.