

ASSEMBLY INSTRUCTIONS

INSTRUCTIONS DE MONTAGE

6PCS DINING SET

6 PIÈCES ENSEMBLE DE À MANGER

N717P237552

N717P237553

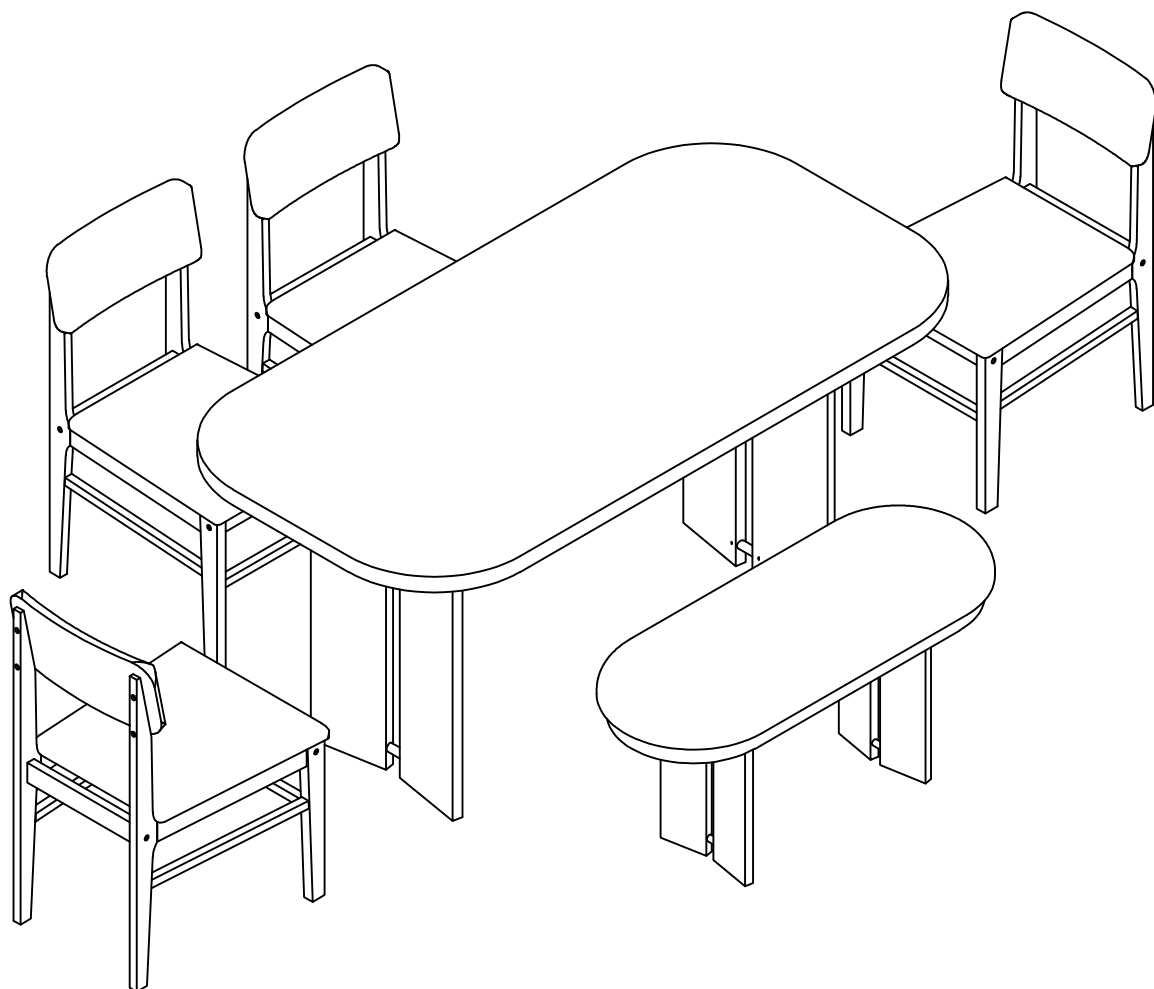

ASSEMBLY INSTRUCTIONS

INSTRUCTIONS DE MONTAGE

TABLE ENSEMBLE DE À MANGER

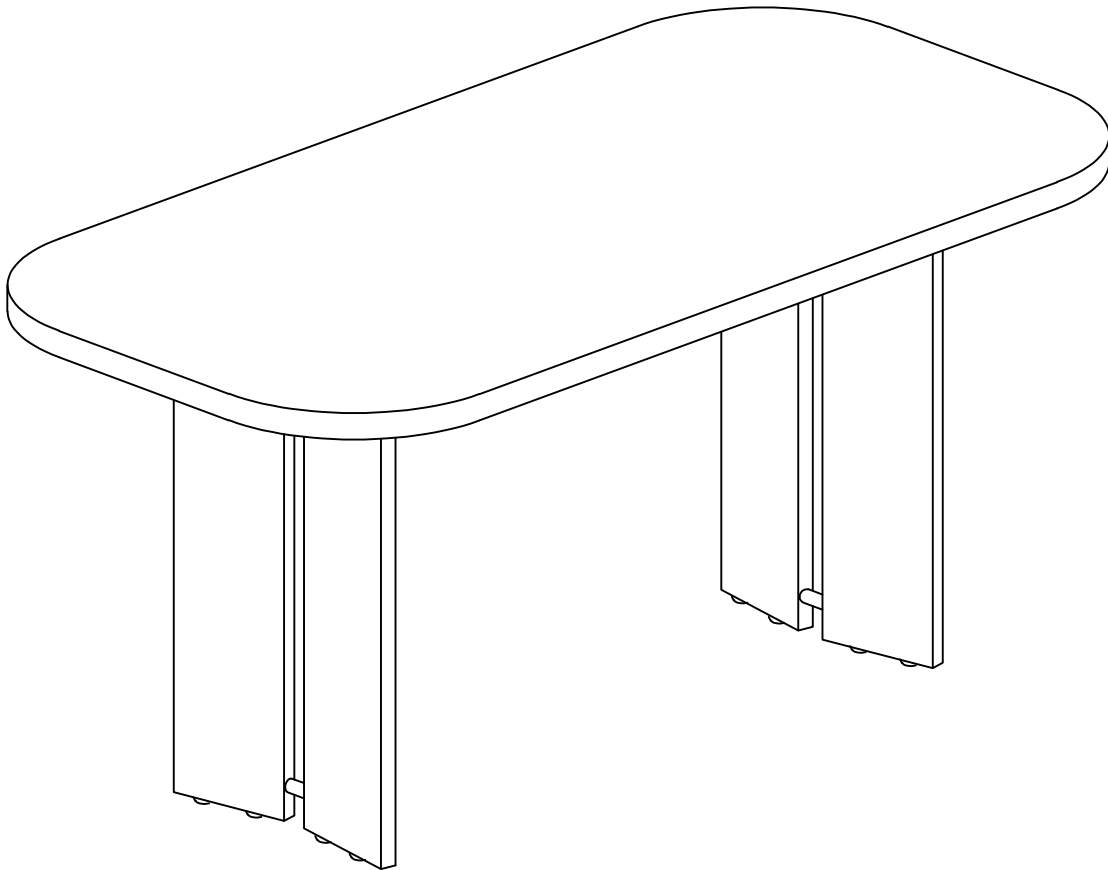

N717P237552

IMPORTANT NOTE :

- 1 PLACE ALL PARTS ON A CLEAN AND SMOOTH SURFACE SUCH AS A RUG OR CARPET TO AVOID THE PARTS FROM BEING SCRATCHED.
- 2 BEFORE YOU BEGIN , KINDLY FOLLOW THE ASSEMBLY INSTRUCTIONS STEP BY STEP.
- 3 DO NOT TIGHTEN ALL SCREWS AND BOLTS UNTIL THE CHAIR IS FULLY SET-UP

NOTE IMPORTANTE :

- 1 PLACEZ TOUTES LES PIÈCES SUR UNE SURFACE PROPRE ET LISSE COMME UN TAPIS OU UN TAPIS POUR ÉVITER QUE LES PIÈCES SOIENT RAYÉES.
- 2 AVANT DE COMMENCER, VEUILLEZ SUIVRE LES INSTRUCTIONS DE MONTAGE ÉTAPE PAR ÉTAPE.
- 3 NE SERREZ PAS TOUTES LES VIS ET TOUS LES BOULONS JUSQU'À CE QUE LA CHAISE SOIT COMPLÈTEMENT INSTALLÉE

Detail View



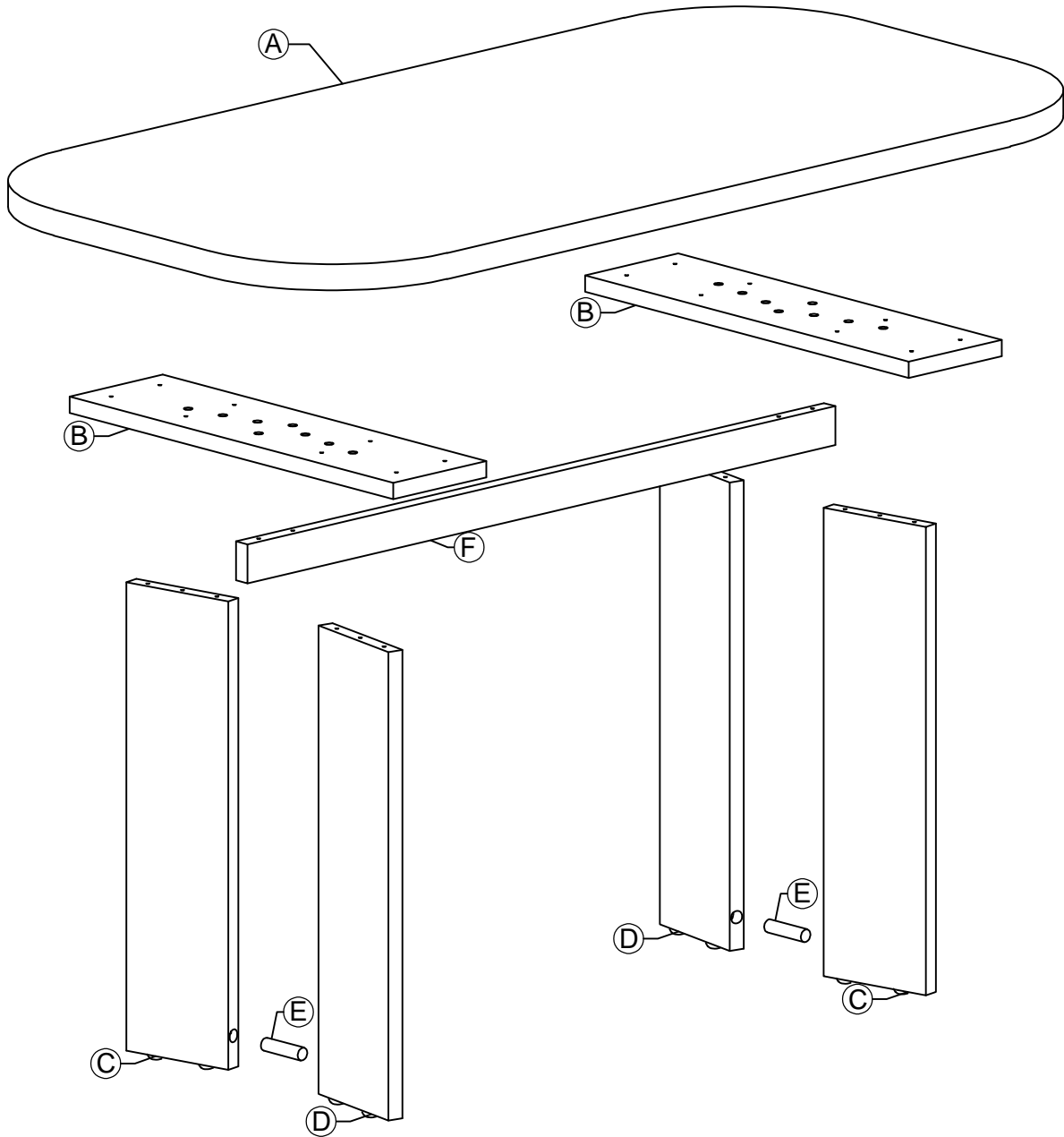

Vue Détaillée

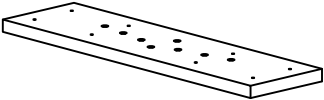
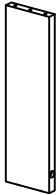
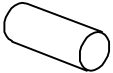
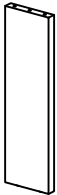
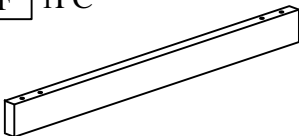

Part List
Liste des pièces

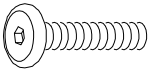
<p>A 1PC</p>  <p>Table Top Plateau de table</p>	<p>B 2PCS</p>  <p>Leg Support Bar Barre de support pour les jambes</p>	<p>C 2PCS</p>  <p>Leg Jambe</p>	<p>E 2PCS</p>  <p>Round Bar Barre ronde</p>
		<p>D 2PCS</p>  <p>Leg Jambe</p>	<p>F 1PC</p>  <p>Cross Bar Barre transversale</p>

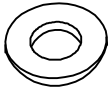
Hardware List
Liste des matériel

<p>① x 32PCS</p>  <p>Ø5/16 * 40 mm</p>	<p>② 32PCS</p>  <p>Ø5/16 * 13 mm</p>	<p>③ x 32 PCS</p>  <p>Ø5/16 * 19mm</p>	<p>④ x 1 PC</p>  <p>4mm</p>
<p>BOLT BouLon</p>	<p>Spring Washer Rondelle elastique</p>	<p>Flat Washer Rondelle plates</p>	<p>Allen Wrench Clé Allen</p>

STEP 1:

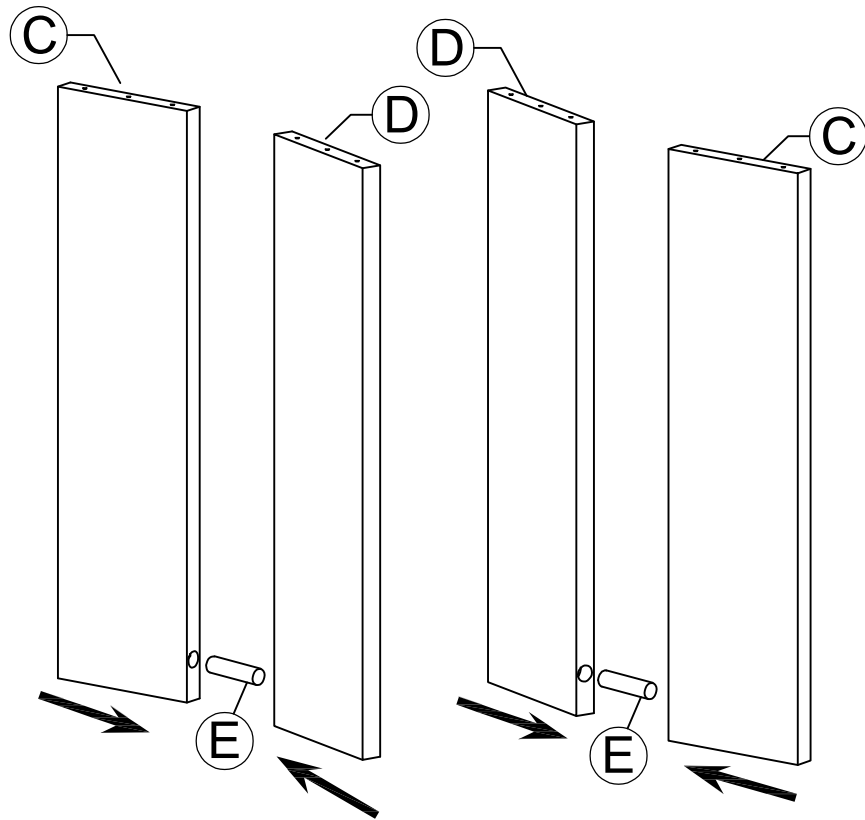

ÉTAPE

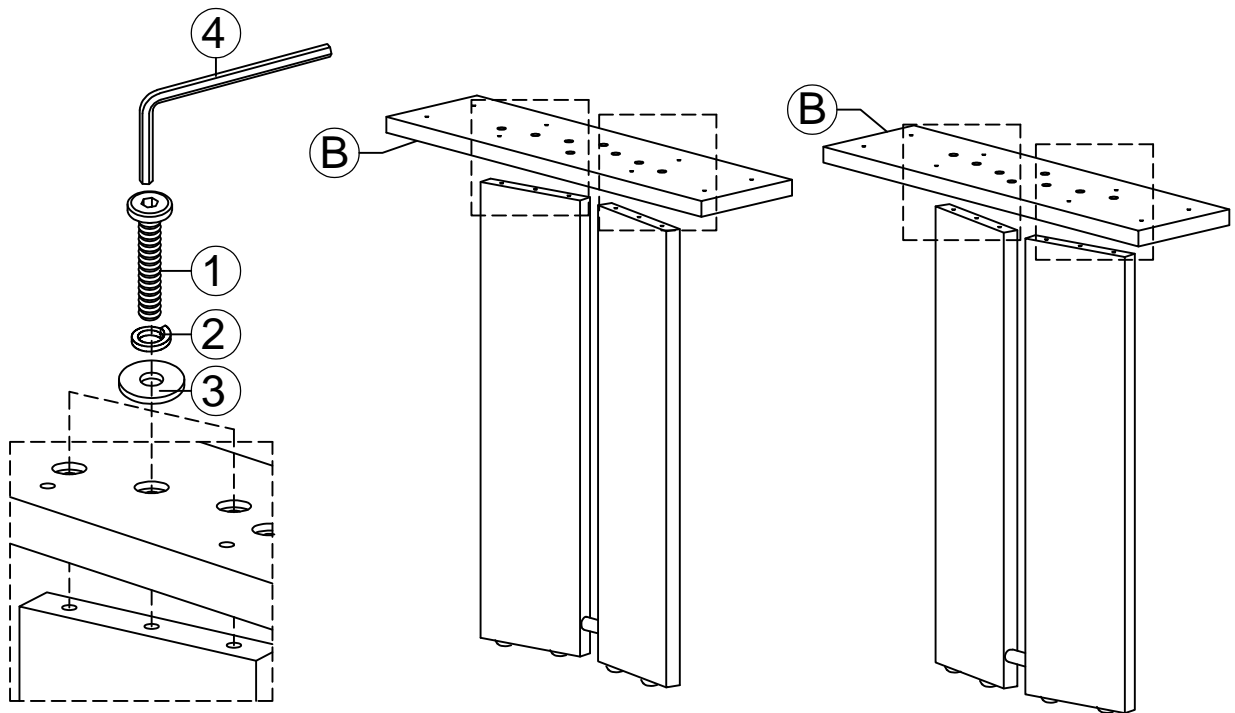

STEP 2:

ÉTAPE





1	Ø5/16*40 mm		12PCS	2	Ø5/16*13 mm		12PCS
3	Ø5/16*19 mm		12PCS	4	4x58		1PC

STEP 3:

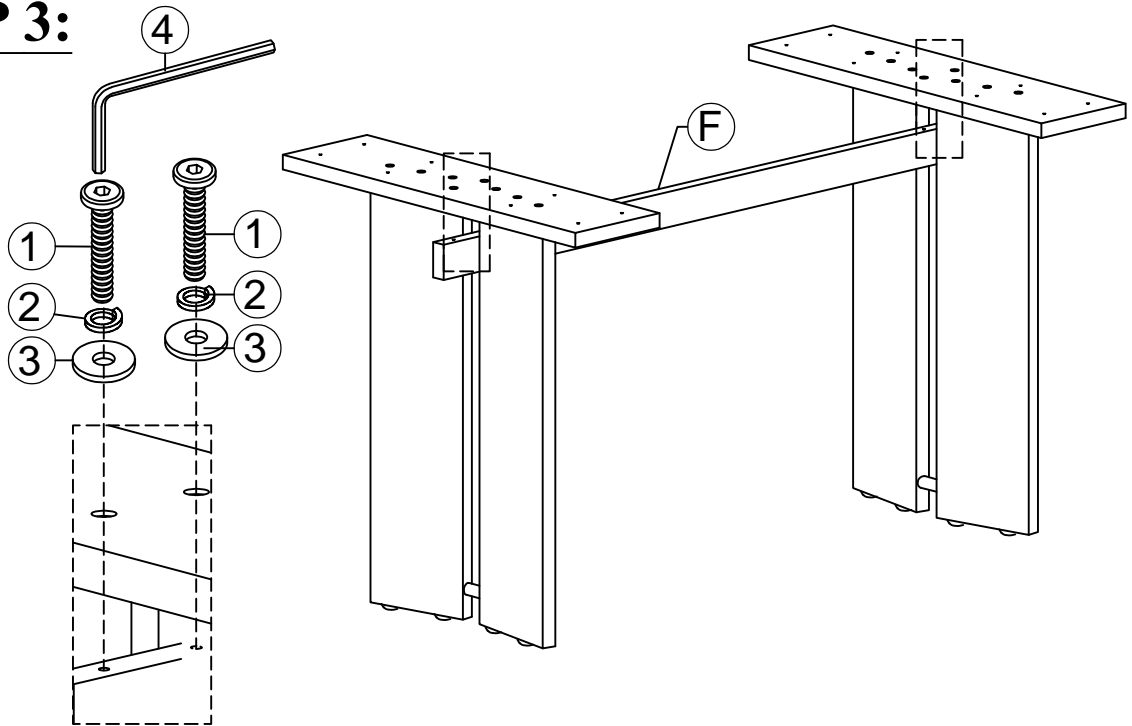
ÉTAPE





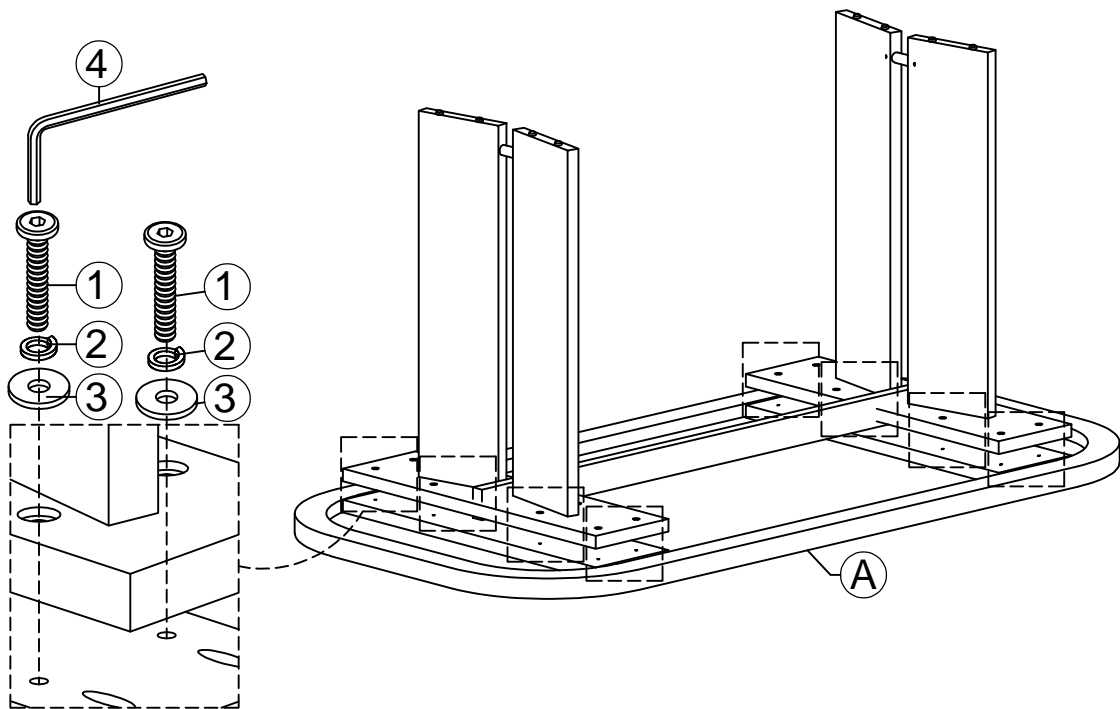

1	Ø5/16*40 mm		4PCS	2	Ø5/16*13 mm		4PCS
3	Ø5/16*19mm		4PCS	4	4x58		1PCS

STEP 4:

ÉTAPE



1	Ø5/16*40 mm		16PCS	2	Ø5/16*13 mm		16PCS
3	Ø5/16*19 mm		16PCS	4	4x58		1PC

STEP 5:

ÉTAPE

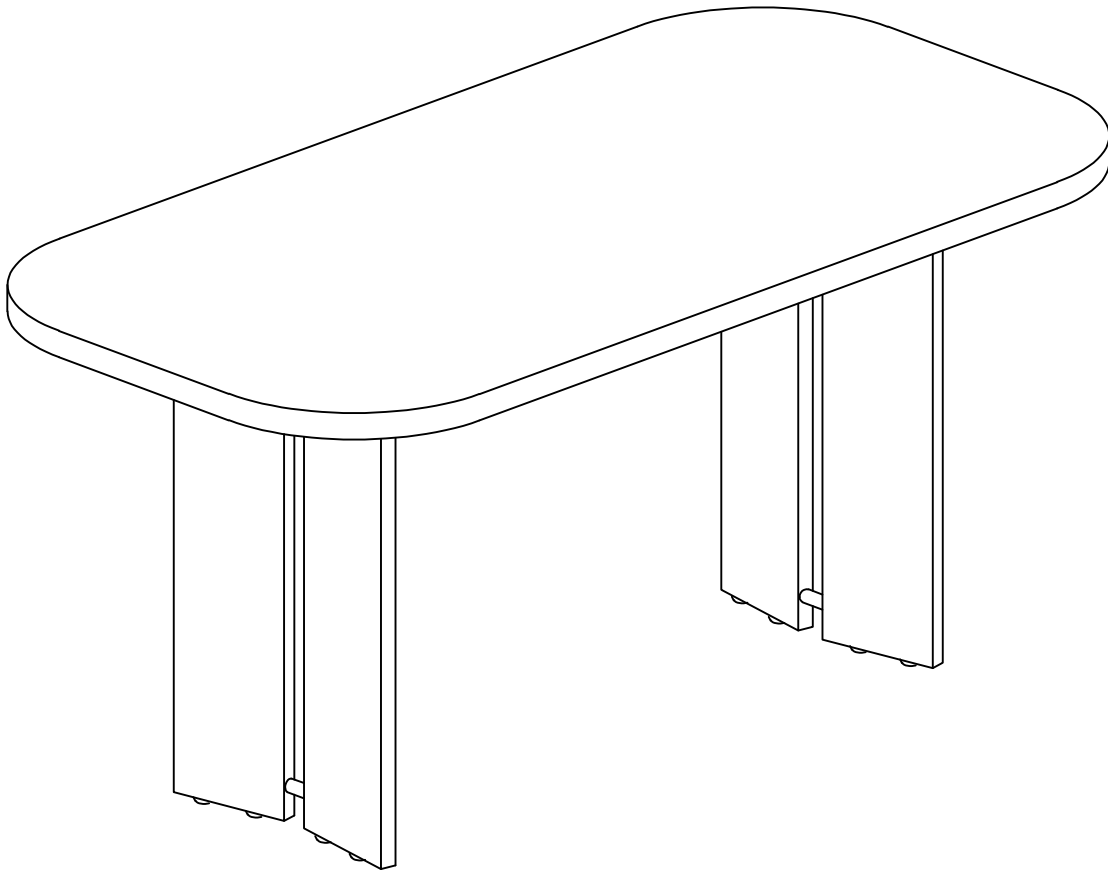

Turn the table over, level it, and tighten all hardware.

ASSEMBLY INSTRUCTIONS

INSTRUCTIONS DE MONTAGE

6PCS DINING SET

6 PIÈCES ENSEMBLE DE À MANGER

N717P237552

N717P237553

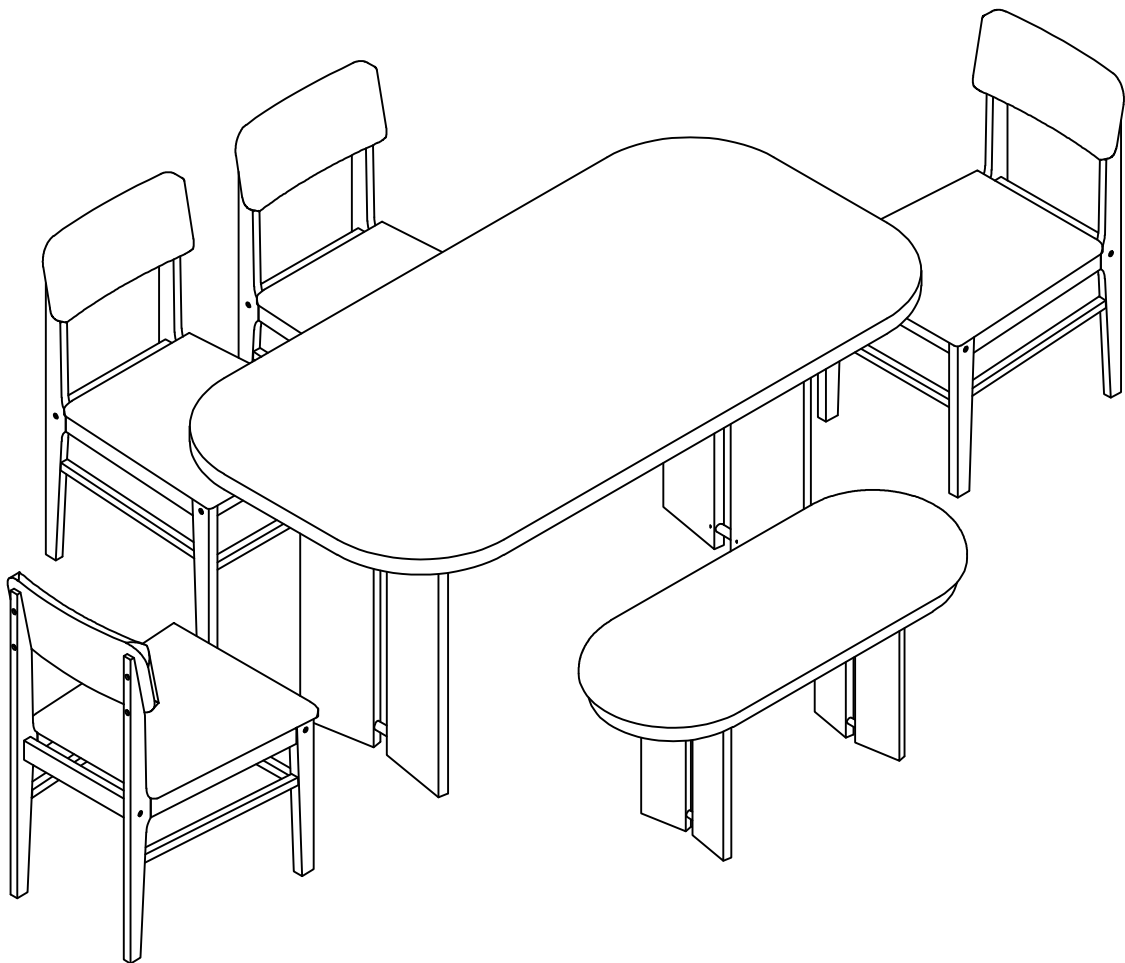

ASSEMBLY INSTRUCTIONS

INSTRUCTIONS DE MONTAGE

DINING CHAIR

CHAISE DE SALLE À MANGER

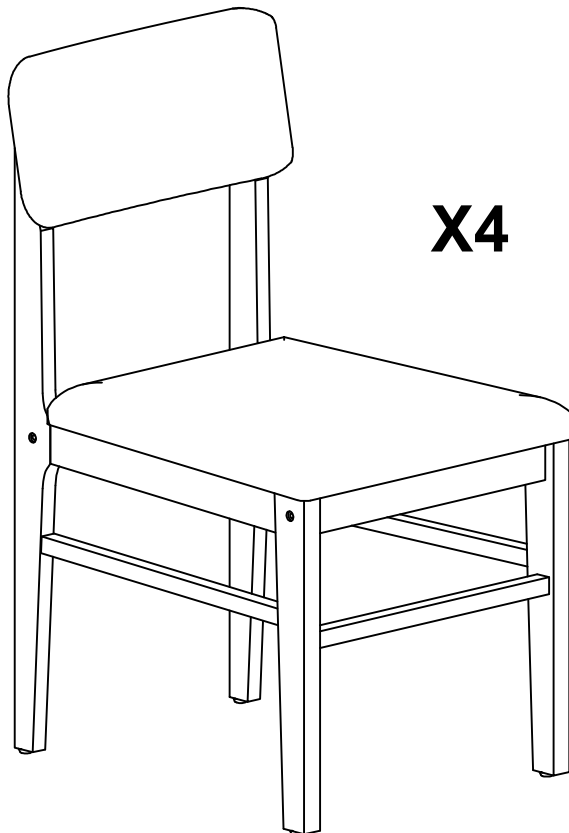

X4

N717P237553

IMPORTANT NOTE :

1 PLACE ALL PARTS ON A CLEAN AND SMOOTH SURFACE SUCH AS A RUG OR CARPET TO AVOID THE PARTS FROM BEING SCRATCHED.

2 BEFORE YOU BEGIN , KINDLY FOLLOW THE ASSEMBLY INSTRUCTIONS STEP BY STEP.

3 DO NOT TIGHTEN ALL SCREWS AND BOLTS UNTIL THE CHAIR IS FULLY SET-UP

NOTE IMPORTANTE :

1 PLACEZ TOUTES LES PIÈCES SUR UNE SURFACE PROPRE ET LISSE COMME UN TAPIS OU UN TAPIS POUR ÉVITER QUE LES PIÈCES SOIENT RAYÉES.

2 AVANT DE COMMENCER, VEUILLEZ SUIVRE LES INSTRUCTIONS DE MONTAGE ÉTAPE PAR ÉTAPE.



3 NE SERREZ PAS TOUTES LES VIS ET TOUS LES BOULONS JUSQU'À CE QUE LA CHAISE SOIT COMPLÈTEMENT INSTALLÉE

Detail View

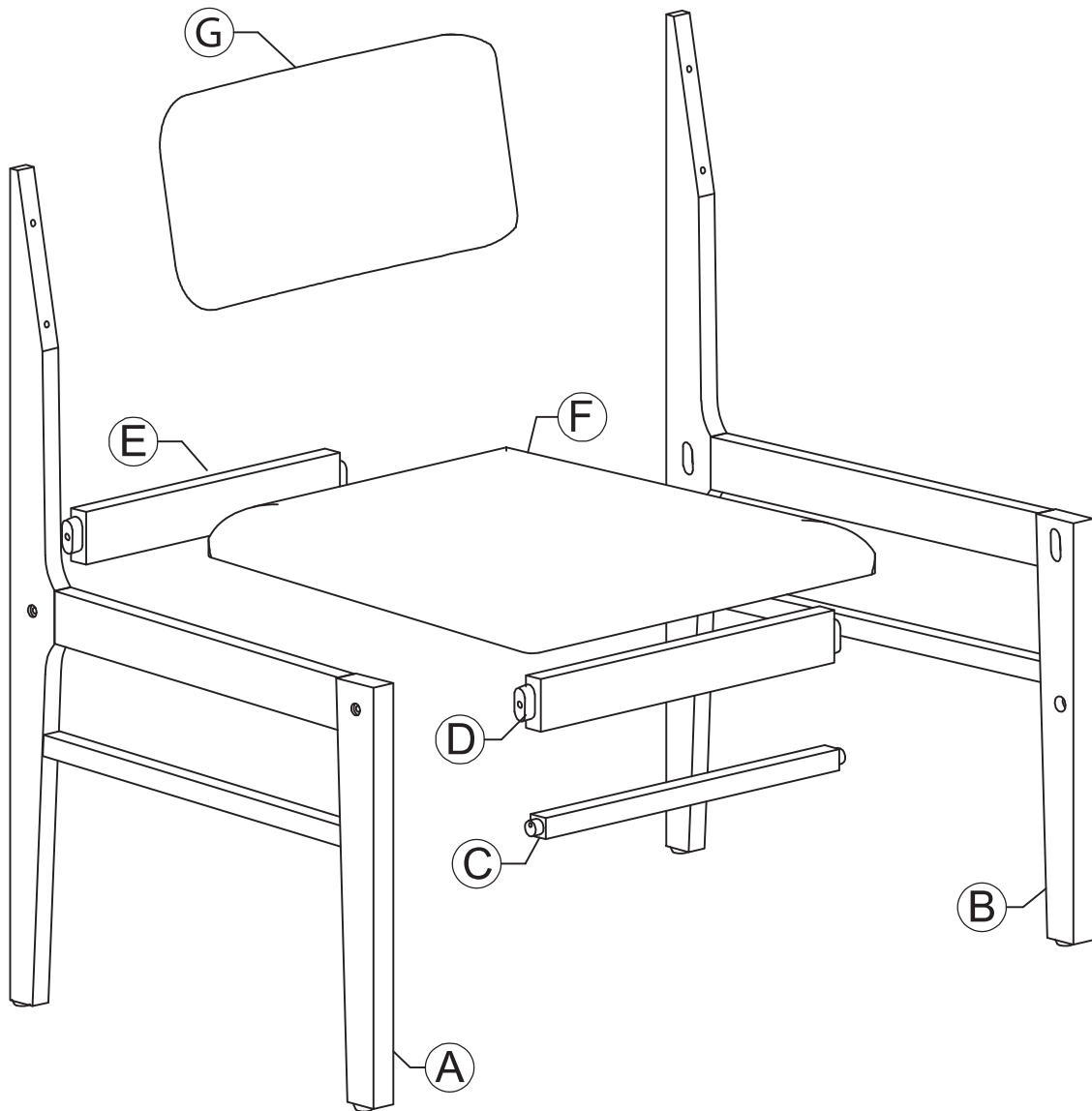





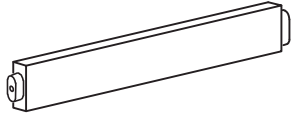
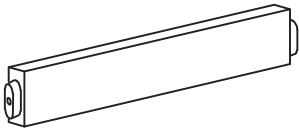
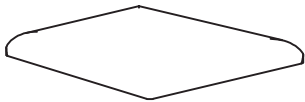
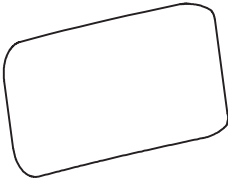

Vue Détaillée

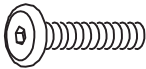

Part List
Liste des pièces

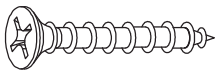
<p>A 1PC</p>  <p>Right Leg Frame Cadre de jambe droite</p>	<p>B 1PC</p>  <p>Left Leg Frame Cadre de jambe gauche</p>	<p>C 1PC</p>  <p>Front Bar Barre avant</p>	<p>D 1PC</p>  <p>Front Bar Barre avant</p>
<p>E 1PC</p>  <p>Back Bar Barre arrière</p>	<p>F 1PC</p>  <p>Seat Cushion Coussin de siège</p>	<p>G 1PC</p>  <p>Back Cushion Coussin de dossier</p>	

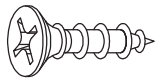



Hardware List For One Chair
Liste du matériel pour une chaise

<p>① x 6PCS</p>  <p>Ø1/4 * 35 mm</p> <p>BOLT BouLon</p>	<p>② 2PCS</p>  <p>Ø1/4 * 25 mm</p> <p>BOLT BouLon</p>	<p>③ x 4 PCS</p>  <p>Ø1/4 * 16 mm</p> <p>Flat Washer Rondelle plates</p>	<p>④ x 4 PCS</p>  <p>Ø1/4 * 13 mm</p> <p>Flat Washer Rondelle plates</p>	<p>⑤ 8PCS</p>  <p>Ø1/4 * 11 mm</p> <p>Spring Washer Rondelle elastique</p>
<p>⑥ x 2 PCS</p>  <p>Ø1/8 * 40mm</p> <p>Screw Vis</p>	<p>⑦ x 4PCS</p> 	<p>⑧ 8PCS</p>  <p>Ø1/8 * 15mm</p> <p>Screw Vis</p>	<p>⑨ x 1 PC</p>  <p>4mm</p> <p>Allen Wrench Clé Allen</p>	

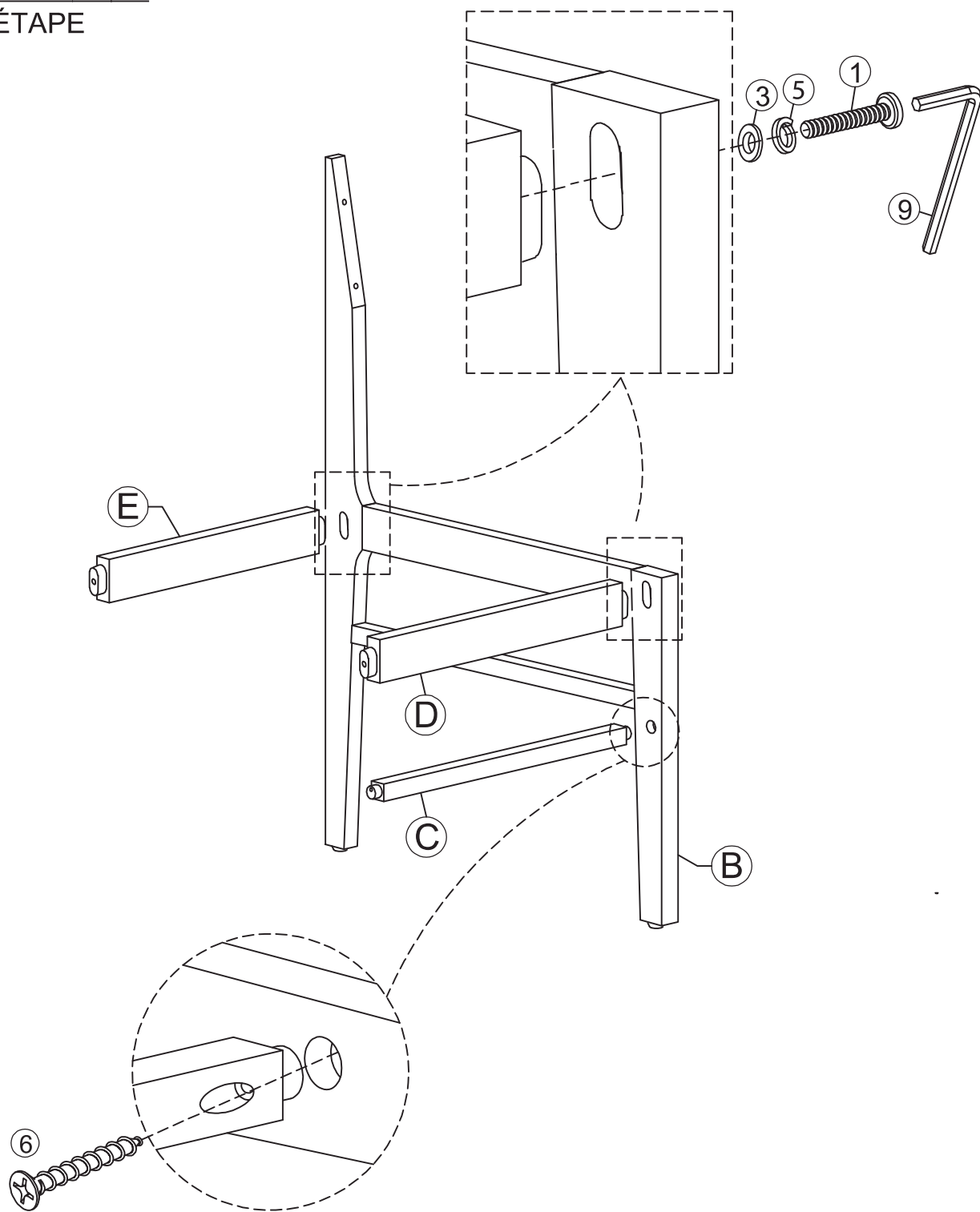
STEP 1:

ÉTAPE

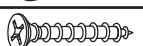



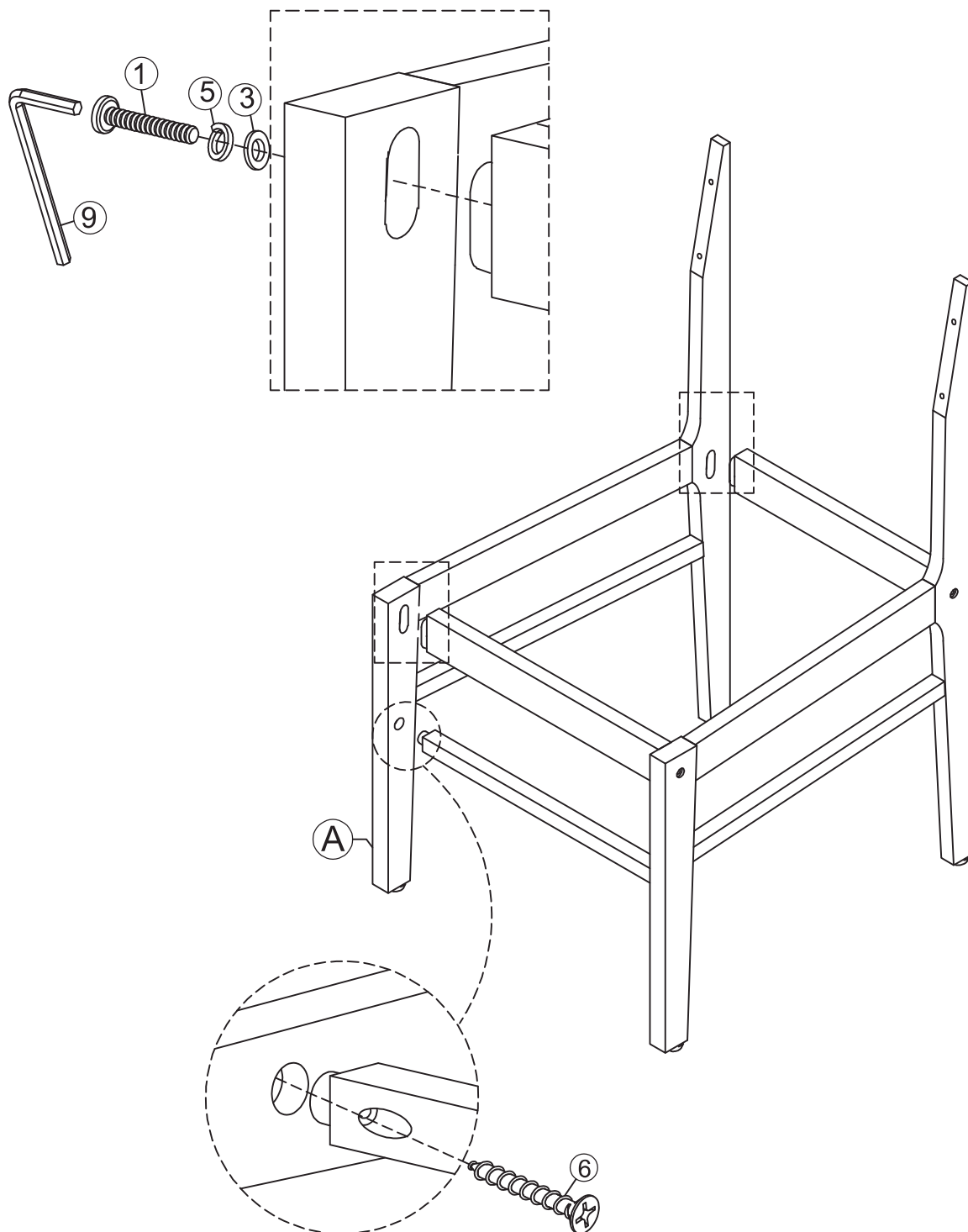

1	Ø1/4*35 mm		2PCS	3	Ø1/4*16 mm		2PCS
5	Ø1/4*11 mm		2PCS	6	Ø1/8*40 mm		1PC
9	4x58		1PC				

STEP 2:

ÉTAPE

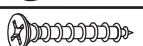



1	Ø1/4*35 mm		2PCS	3	Ø1/4*16 mm		2PCS
5	Ø1/4*11 mm		2PCS	6	Ø1/8*40 mm		1PC
9	4x58		1PC				

STEP 3:

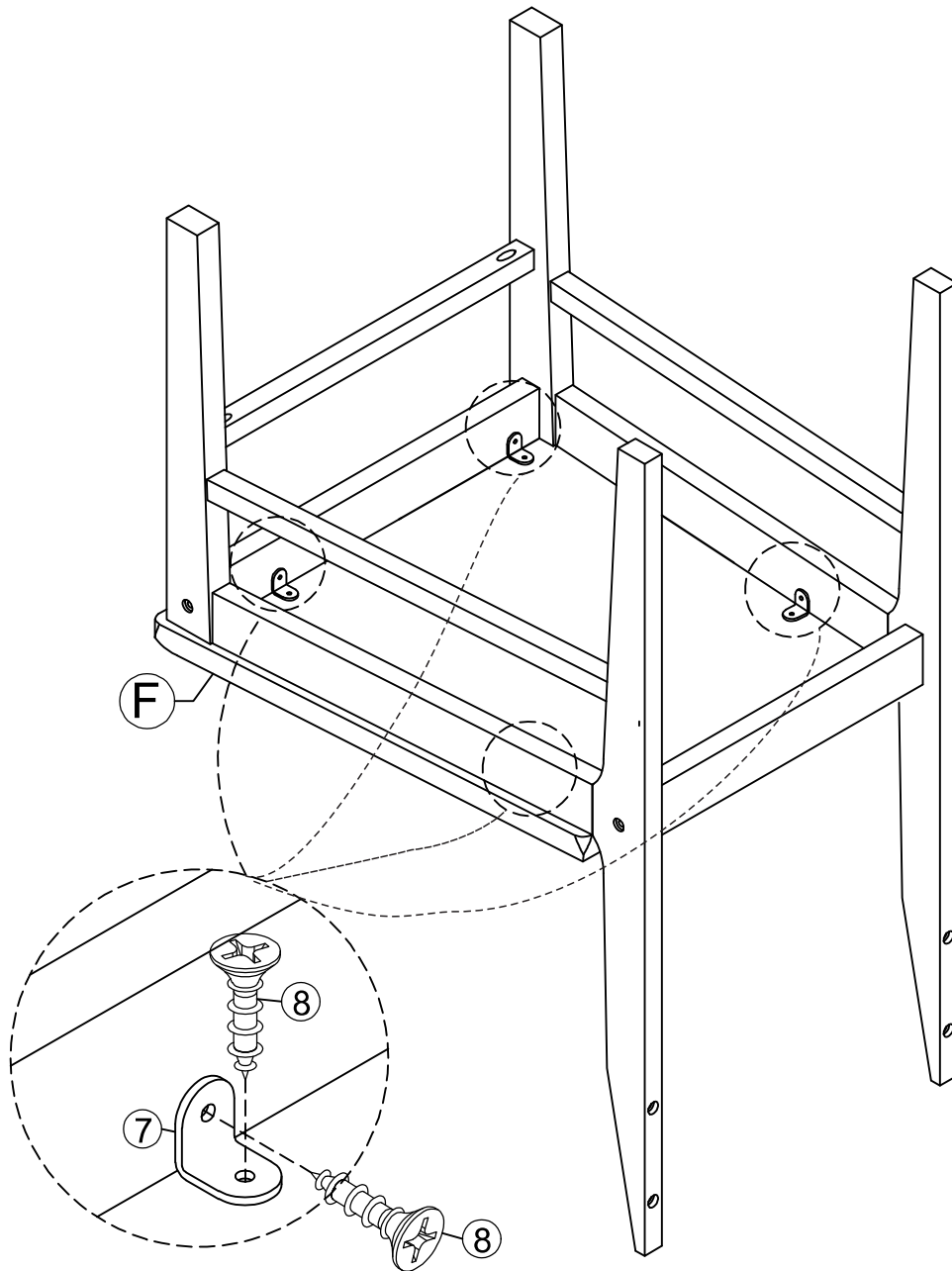
ÉTAPE





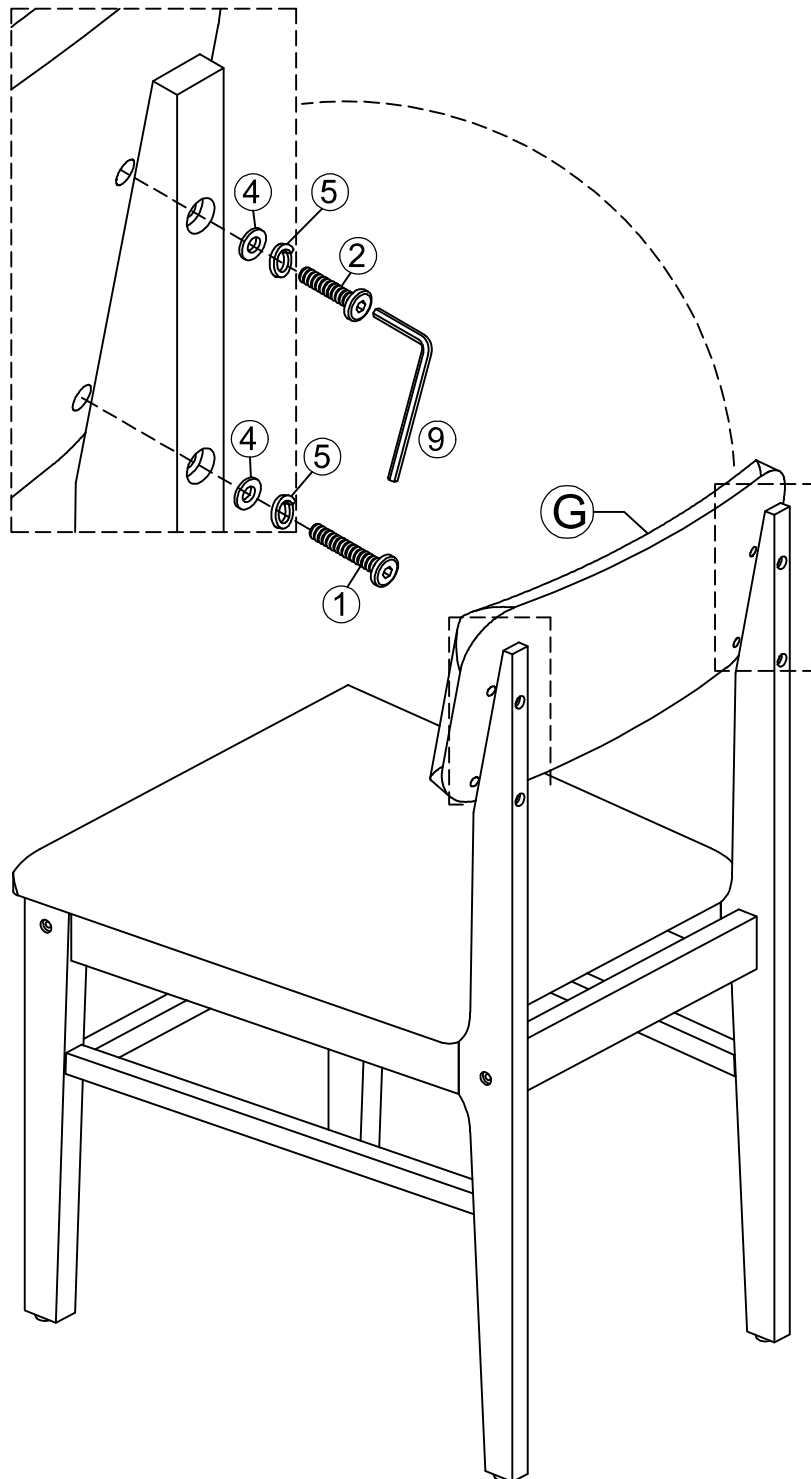

7		4PCS	8	Ø1/8 * 15mm		8PCS
						7/9

STEP 4:

ÉTAPE



1	Ø1/4*35 mm		2PCS	2	Ø1/4*25 mm		2PCS
4	Ø1/4*13 mm		4PCS	5	Ø1/4*11 mm		4PCS
9	4x58		1PC				
							8/9

STEP 5:

ÉTAPE

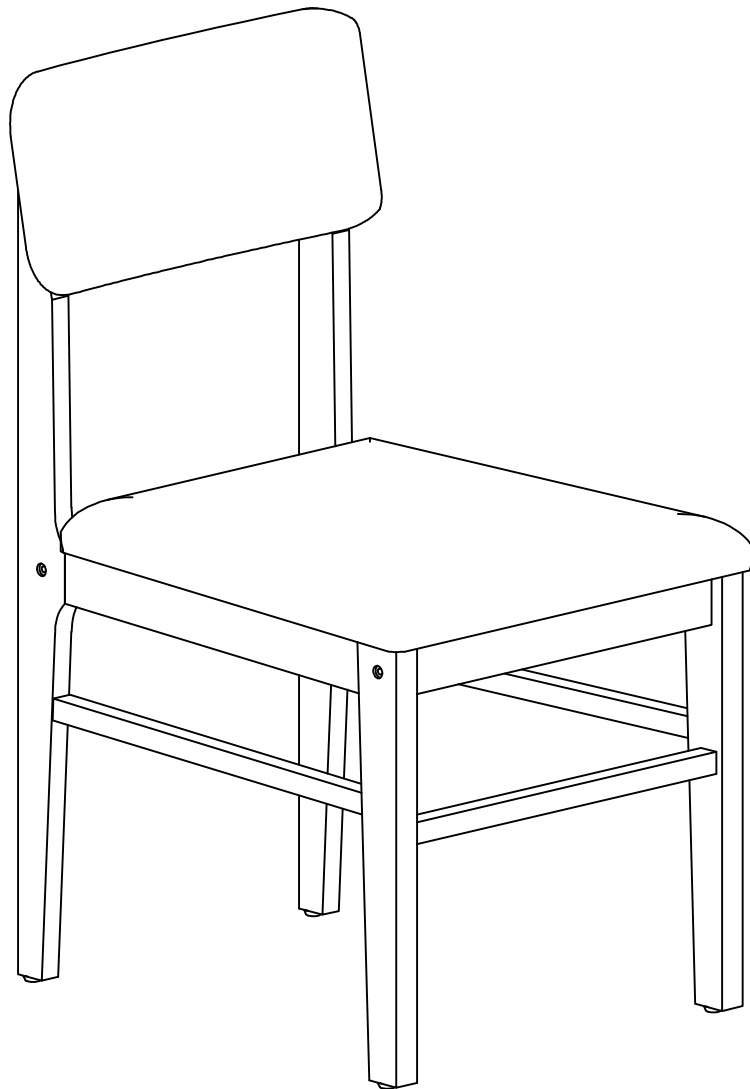

Level it, and tighten all hardware.

ASSEMBLY INSTRUCTIONS

INSTRUCTIONS DE MONTAGE

6PCS DINING SET

6 PIÈCES ENSEMBLE DE À MANGER

N717P237552

N717P237553

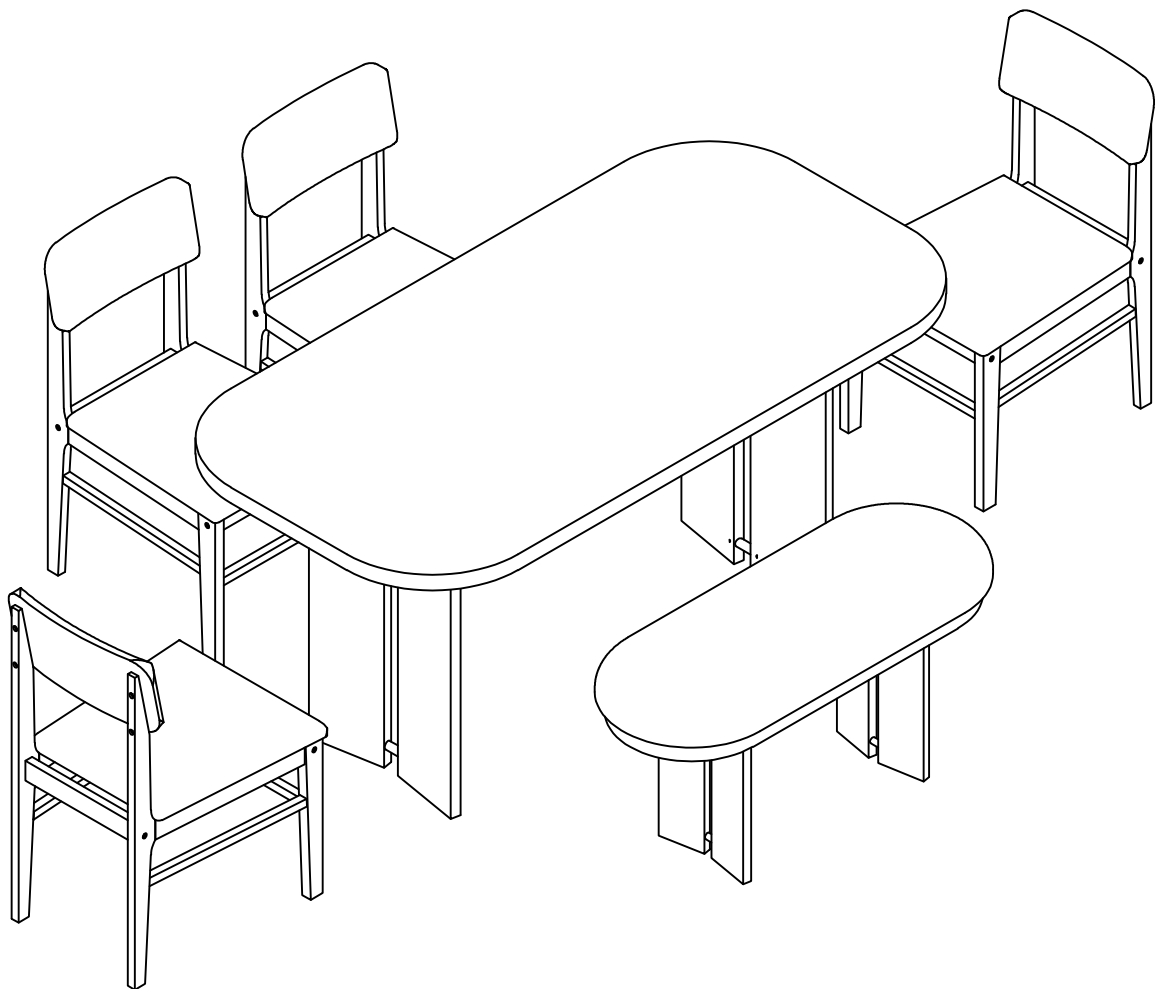

ASSEMBLY INSTRUCTIONS

INSTRUCTIONS DE MONTAGE

BENCH

ENSEMBLE DE SALLE À MANGER AVEC BANC

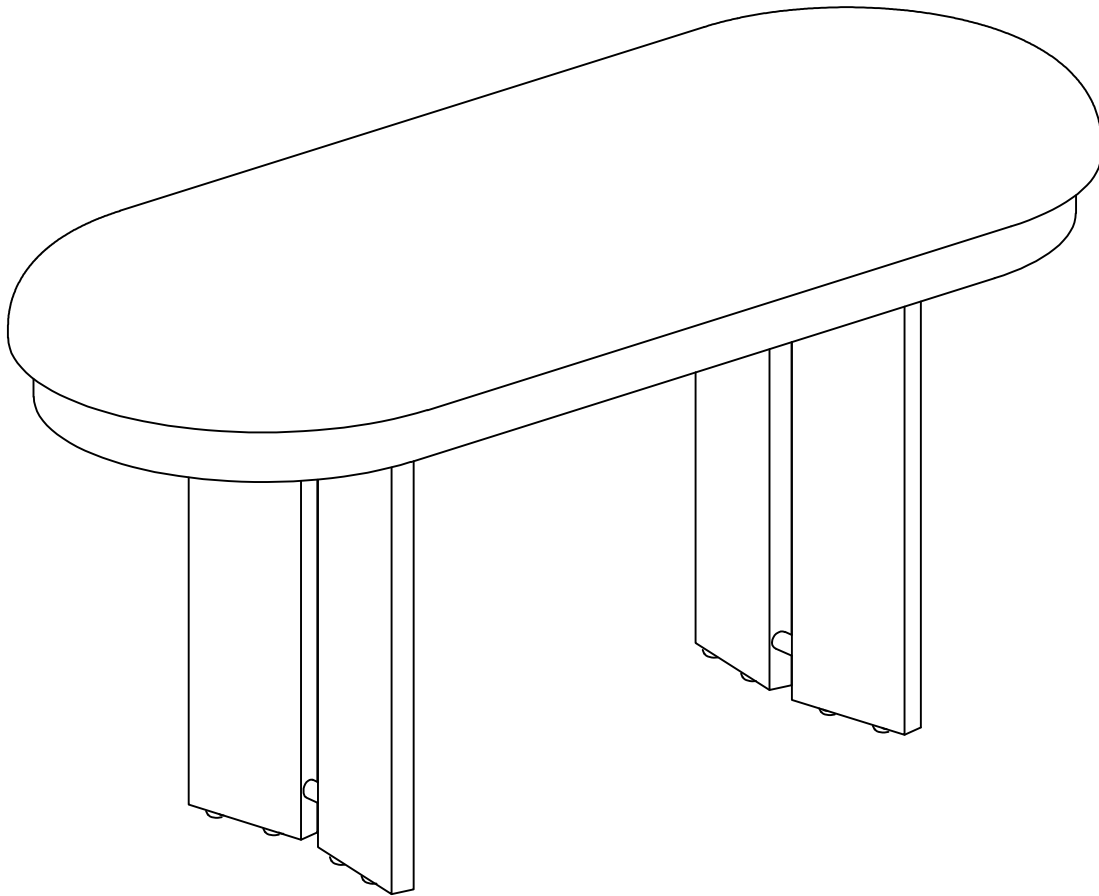

N717P237553

IMPORTANT NOTE :

- 1 PLACE ALL PARTS ON A CLEAN AND SMOOTH SURFACE SUCH AS A RUG OR CARPET TO AVOID THE PARTS FROM BEING SCRATCHED.
- 2 BEFORE YOU BEGIN , KINDLY FOLLOW THE ASSEMBLY INSTRUCTIONS STEP BY STEP.
- 3 DO NOT TIGHTEN ALL SCREWS AND BOLTS UNTIL THE CHAIR IS FULLY SET-UP

NOTE IMPORTANTE :



- 1 PLACEZ TOUTES LES PIÈCES SUR UNE SURFACE PROPRE ET LISSE COMME UN TAPIS OU UN TAPIS POUR ÉVITER QUE LES PIÈCES SOIENT RAYÉES.
- 2 AVANT DE COMMENCER, VEUILLEZ SUIVRE LES INSTRUCTIONS DE MONTAGE ÉTAPE PAR ÉTAPE.
- 3 NE SERREZ PAS TOUTES LES VIS ET TOUS LES BOULONS JUSQU'À CE QUE LA CHAISE SOIT COMPLÈTEMENT INSTALLÉE

Detail View

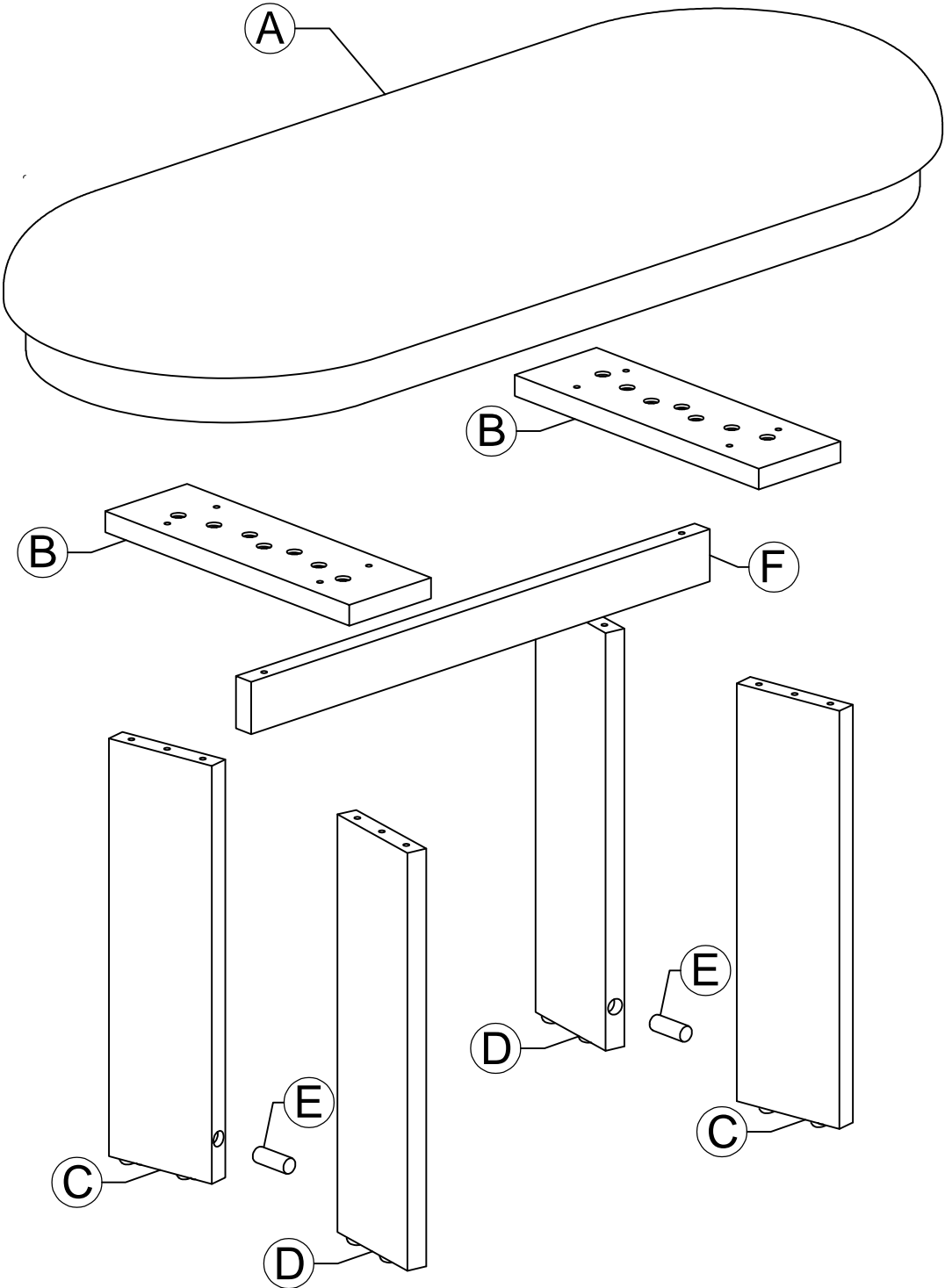

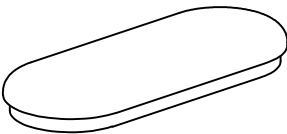
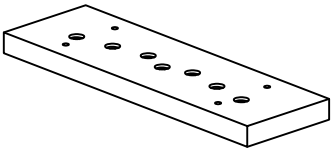

Vue Détaillée

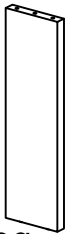
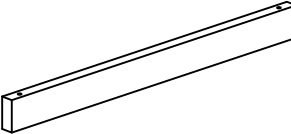

Part List
Liste des pièces

<p>A 1PC</p>  <p>Seat Frame With Cushion Cadre de siège avec coussin</p>	<p>B 2PCS</p>  <p>Leg Support Bar Barre de support pour les jambes</p>	<p>C 2PCS</p>  <p>Leg Jambe</p>	<p>E 2PCS</p>  <p>Round Bar Barre ronde</p>
		<p>D 2PCS</p>  <p>Leg Jambe</p>	<p>F 1PC</p>  <p>Cross Bar Barre transversale</p>

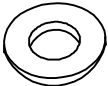
Hardware List
Liste des matériel

<p>① x 24PCS</p>  <p>Ø1/4 * 35 mm</p>	<p>② 24PCS</p>  <p>Ø1/4 * 11 mm</p>	<p>③ x 24 PCS</p>  <p>Ø1/4 * 19mm</p>	<p>④ x 1 PCS</p>  <p>4mm</p>
<p>BOLT BouLon</p>	<p>Spring Washer Rondelle elastique</p>	<p>Flat Washer Rondelle plates</p>	<p>Allen Wrench Clé Allen</p>

STEP 1:



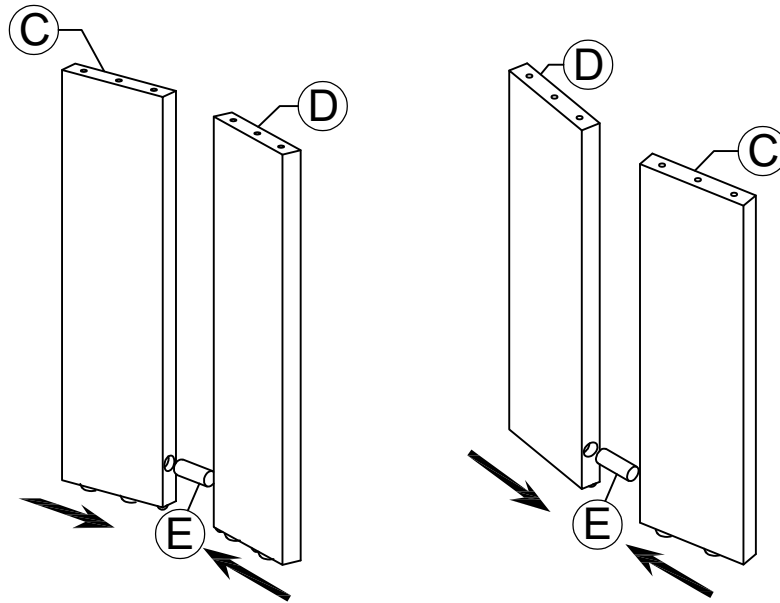

ÉTAPE

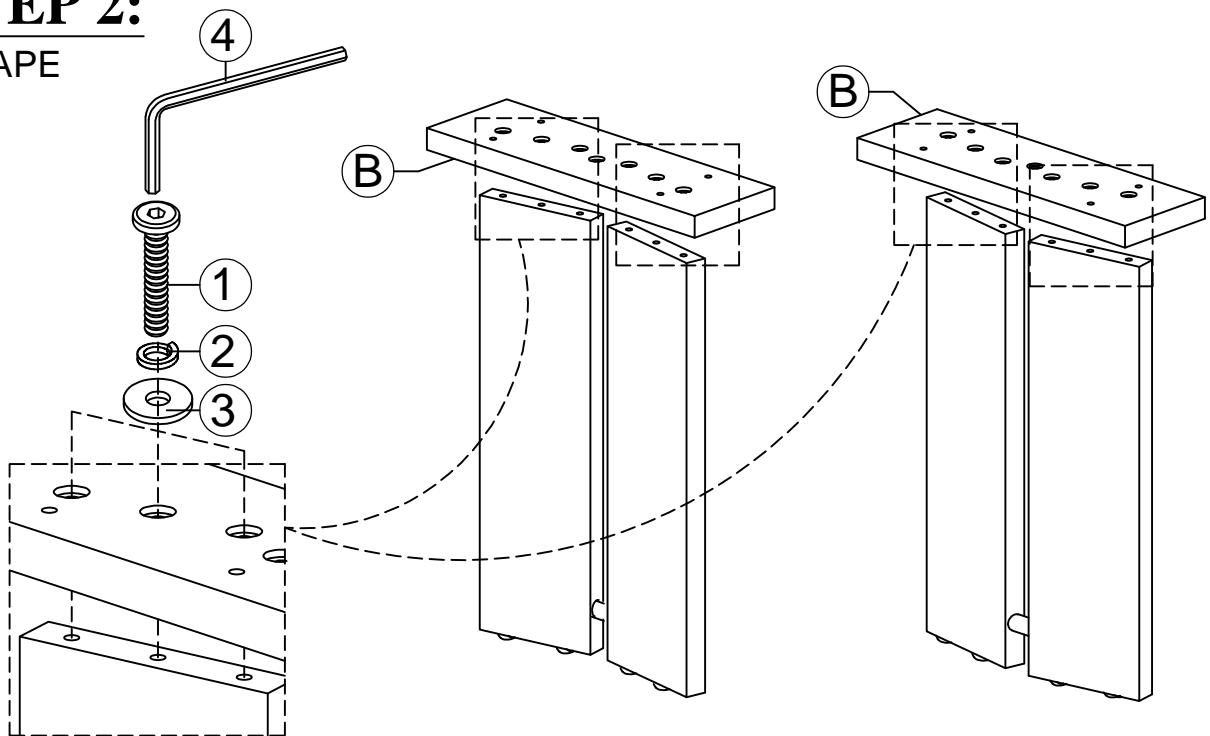

STEP 2:

ÉTAPE





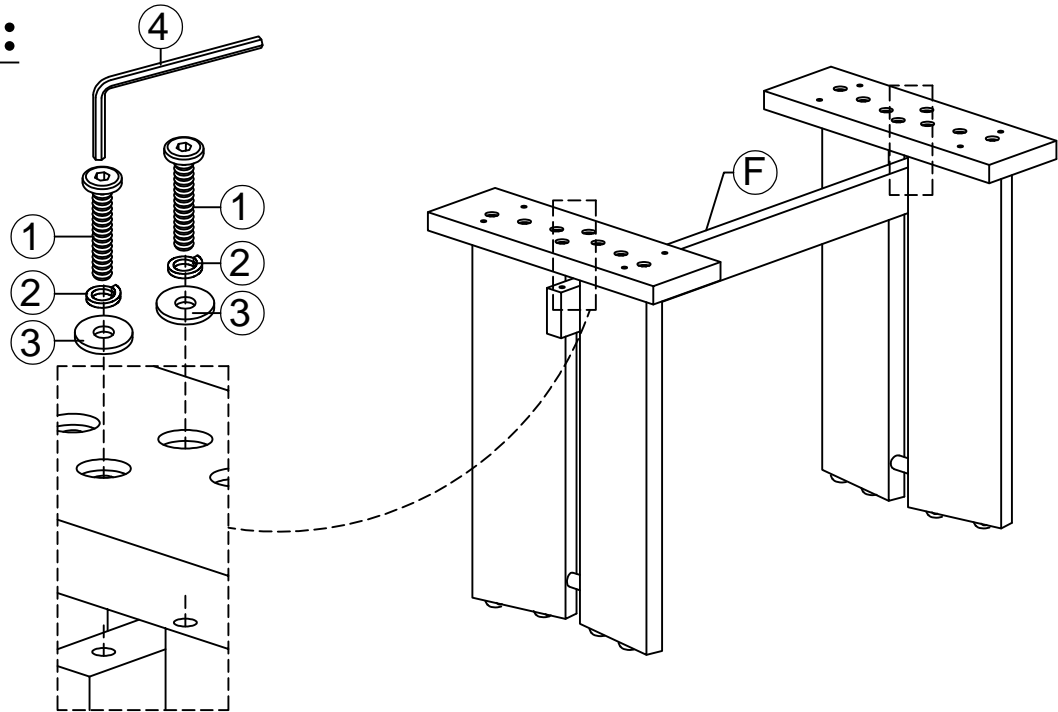

1	Ø1/4*35 mm		12PCS	2	Ø1/4*11 mm		12PCS
3	Ø1/4*19mm		12PCS	4	4x58		1PCS
							5/7

STEP 3:

ÉTAPE





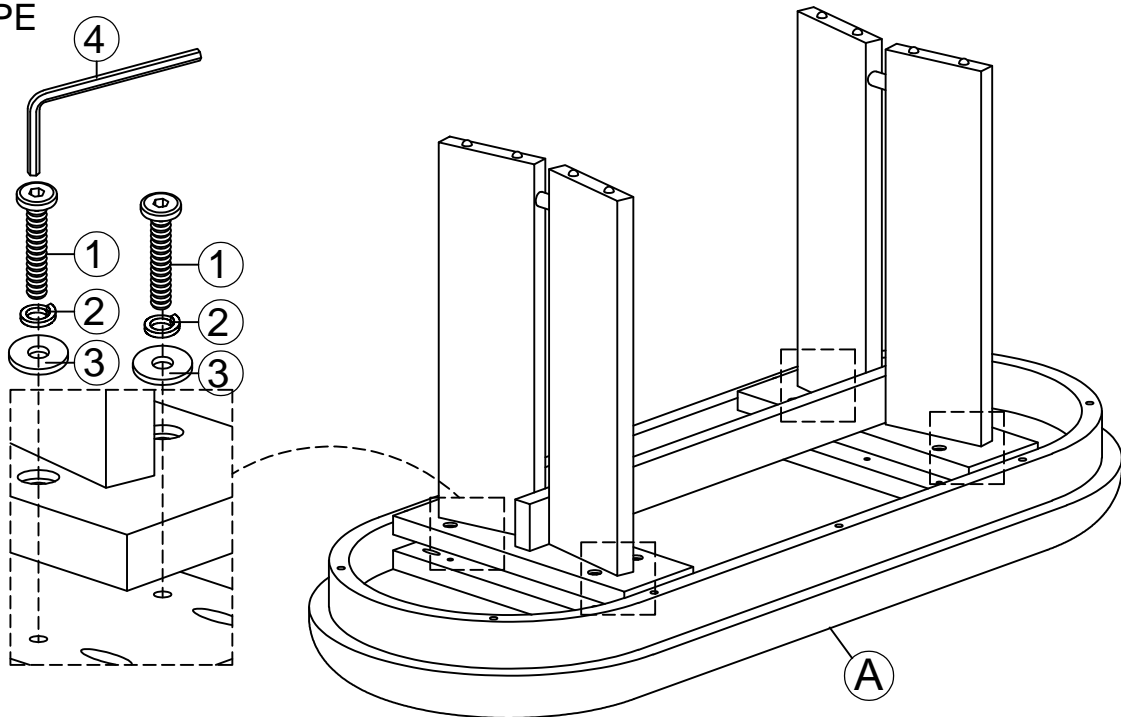

1	Ø1/4*35 mm		4PCS	2	Ø1/4*11 mm		4PCS
3	Ø1/4*19 mm		4PCS	4	4x58		1PCS

STEP 4:

ÉTAPE



1	Ø1/4*35 mm		8PCS	2	Ø1/4*11 mm		8PCS
3	Ø1/4*19 mm		8PCS	4	4x58		1PCS

STEP 5:

ÉTAPE

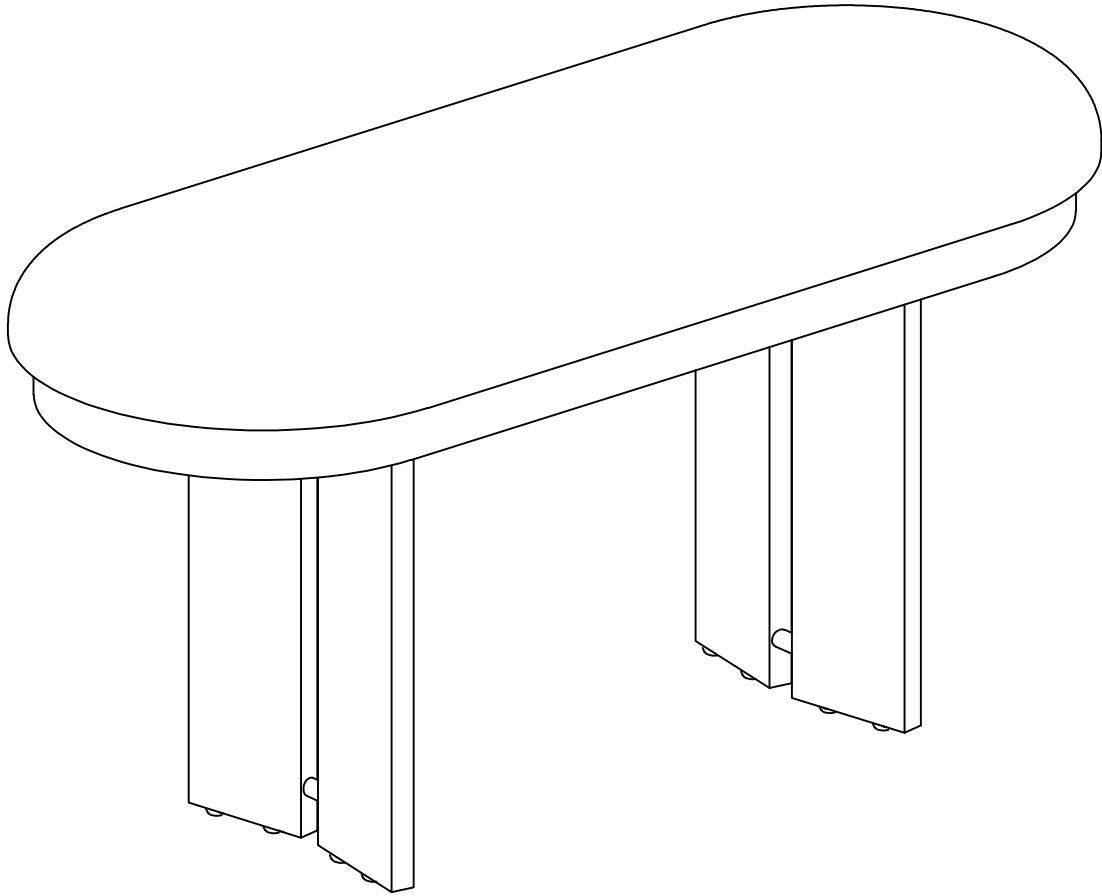

Turn the bench over, level it, and tighten all hardware.