

Multifunctional storage

Assembly Instructions

we recommend using the included manual installation tool for assembly.
If you choose to use a power drill, please set it to the lowest torque setting
to prevent over-tightening, which may damage the wooden panels.

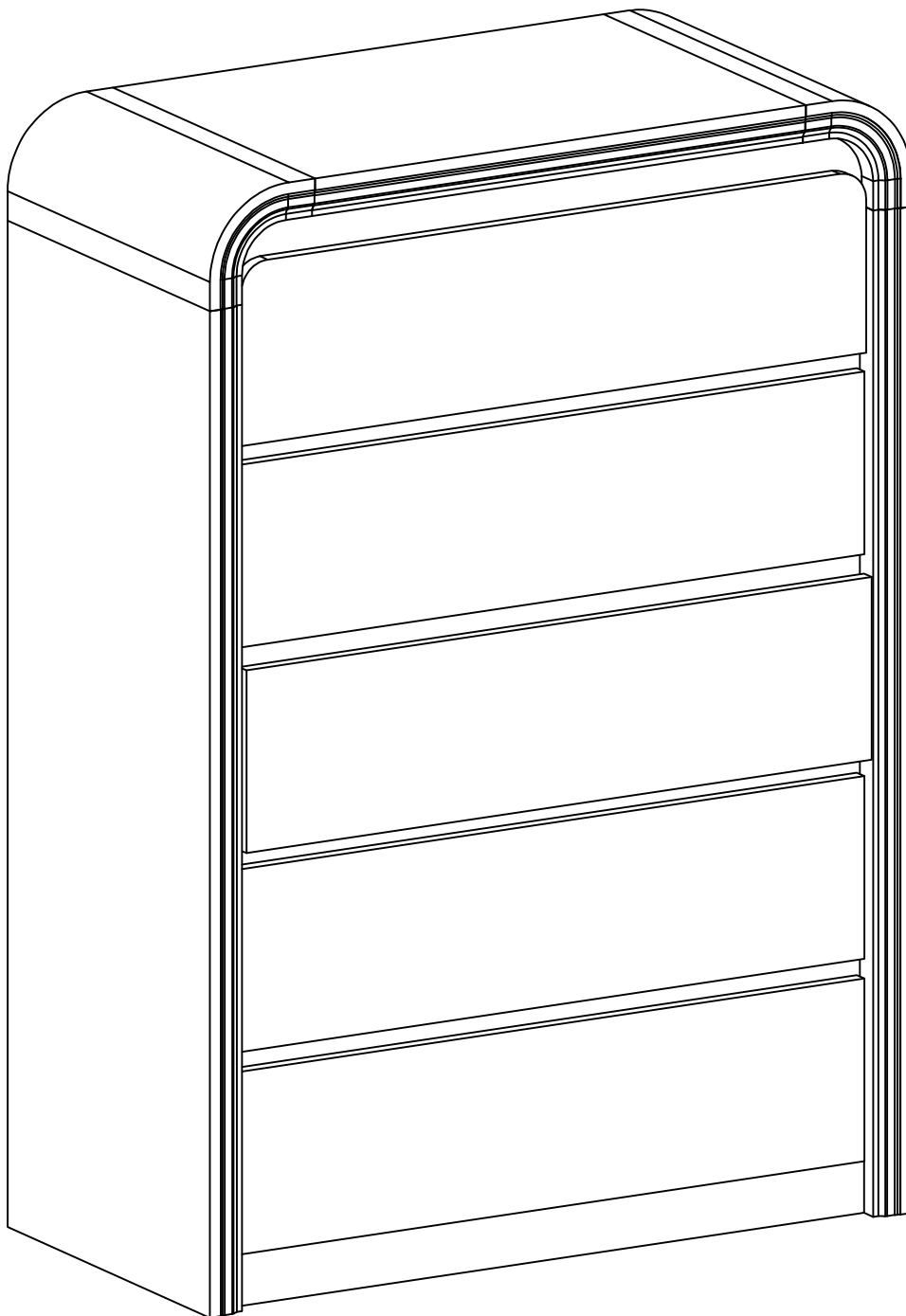

Parts List

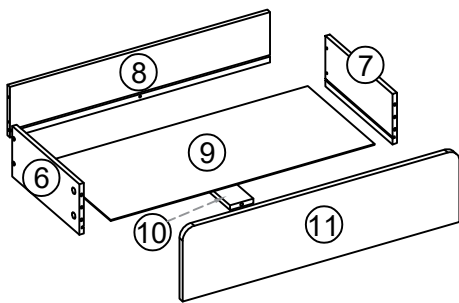
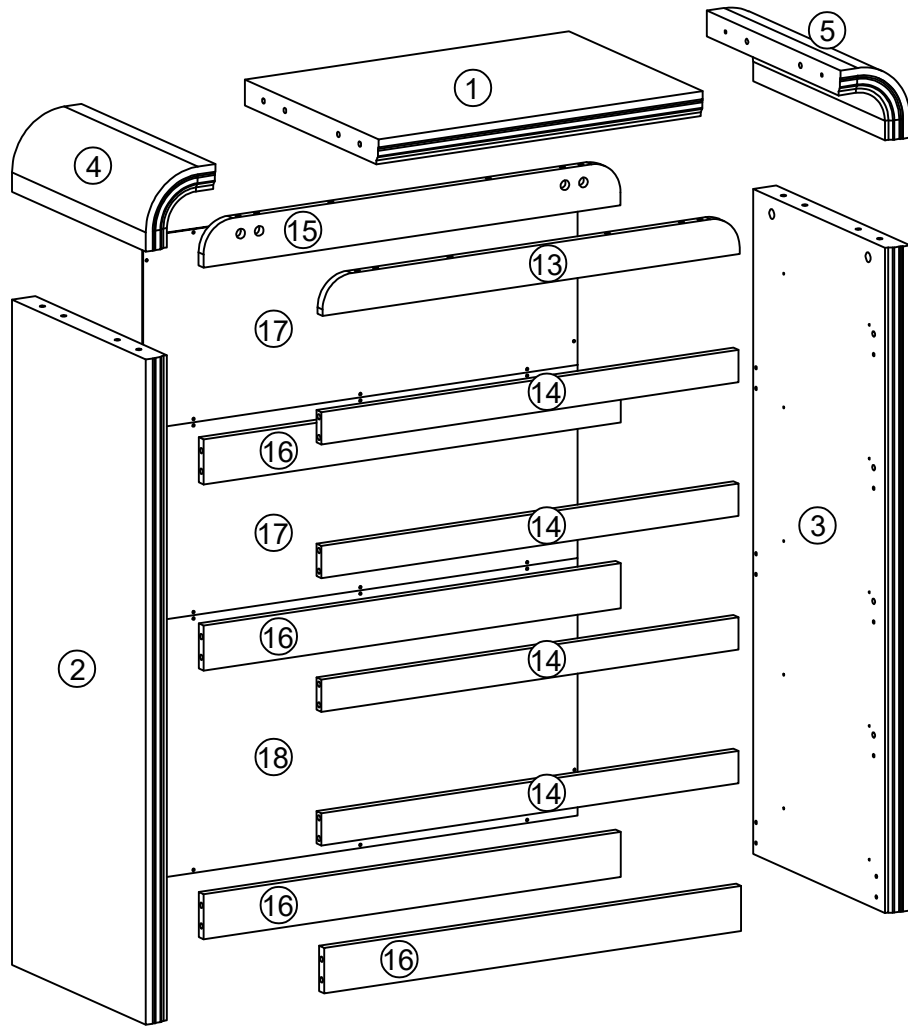

X1

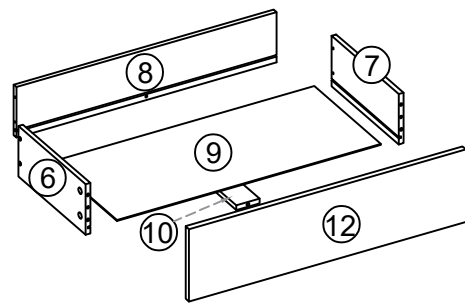

X4

Hardware

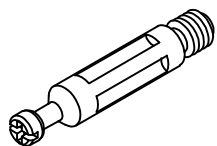

A x 71sets

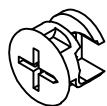

Ø15X9.5MM

B x 71sets

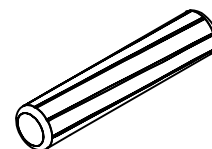

Ø8 x 30MM

C x 22pcs

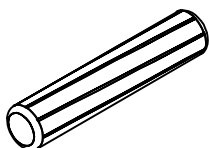

Ø6 x 30MM

D x 12pcs

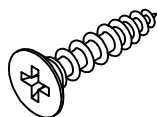

3.5 x 12MM

E x 42pcs

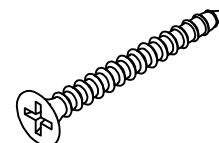

3.5 x 35MM

F x27pcs

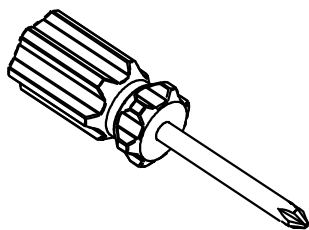

G x 1sets

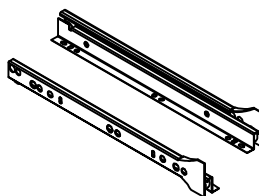

300MM

H x 5sets

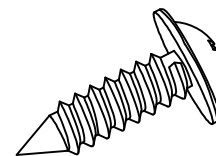





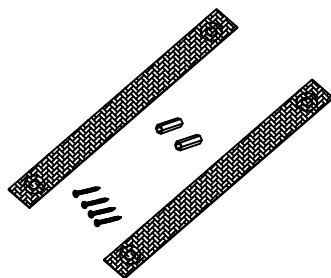



3.5 x 12MM

I x32pcs

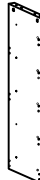
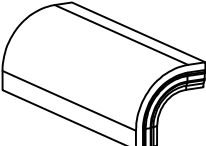
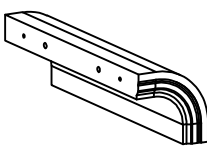
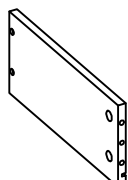
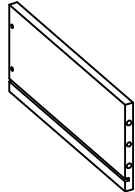
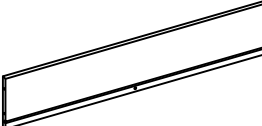

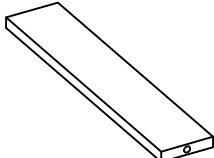
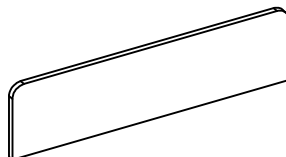
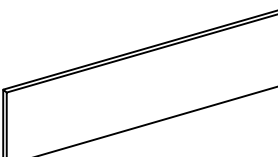
J x 1sets

ASSEMBLY MATERIAL

Item no.	Reference Image	Oty.	Item no.	Reference Image	Oty.
①		X1	②		X1
③		X1	④		X1
⑤		X1	⑥		X5
⑦		X5	⑧		X5
⑨		X5	⑩		X5
⑪		X1	⑫		X4
⑬		X1	⑭		X4
⑮		X1	⑯		X4

ASSEMBLY MATERIAL

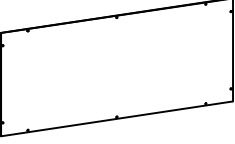
Item no.	Reference Image	Qty.
17		X2

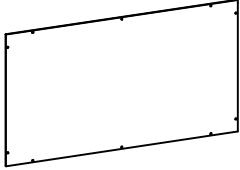
Item no.	Reference Image	Qty.
18		X1

Step 1

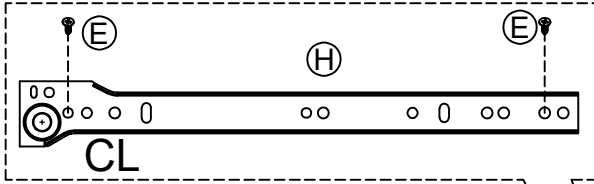
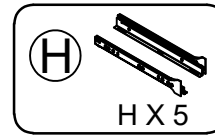
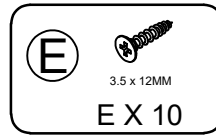
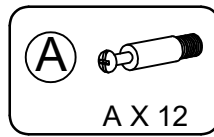

Install first rail on the left side of board.

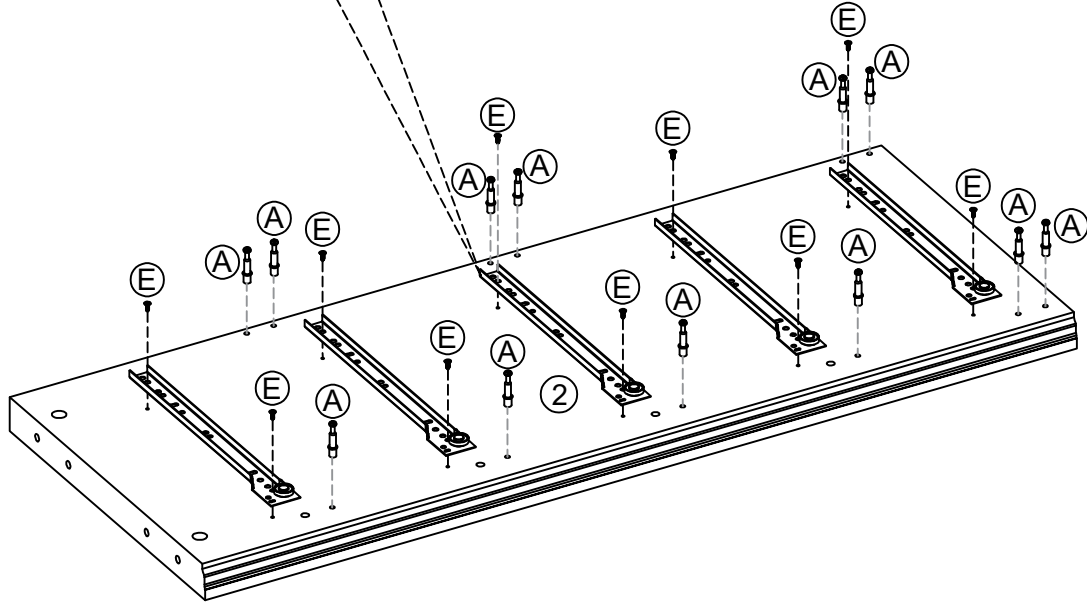

Step 2

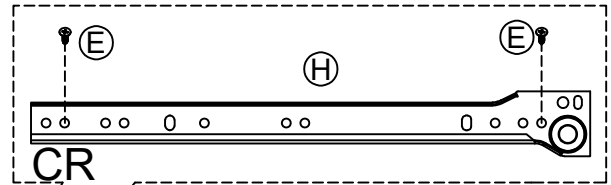
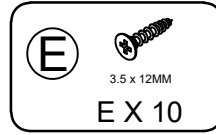
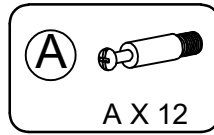

Install first rail on the right side of board.

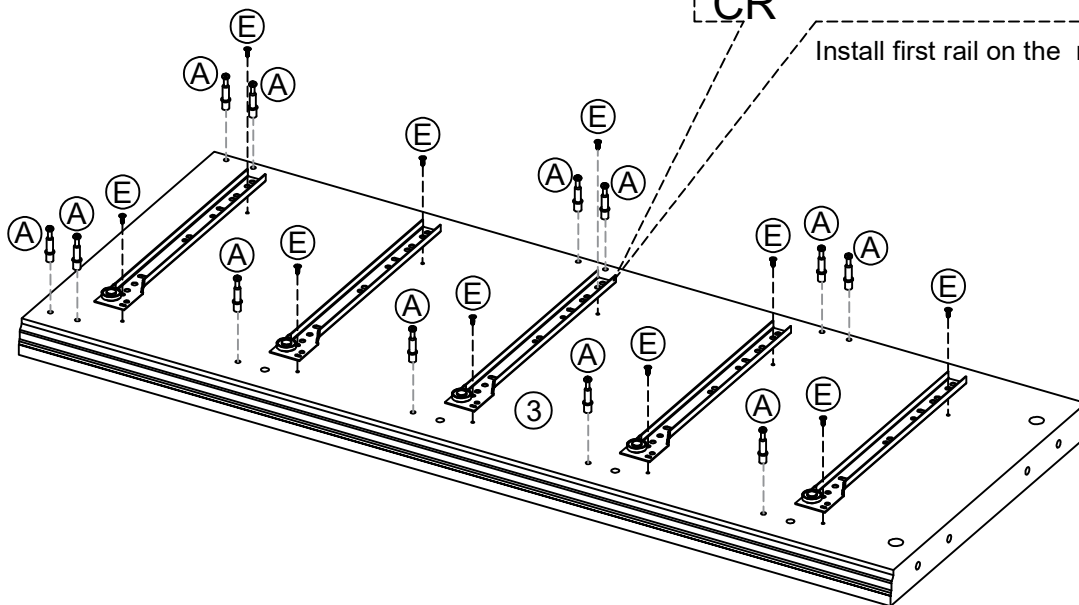

Step 3

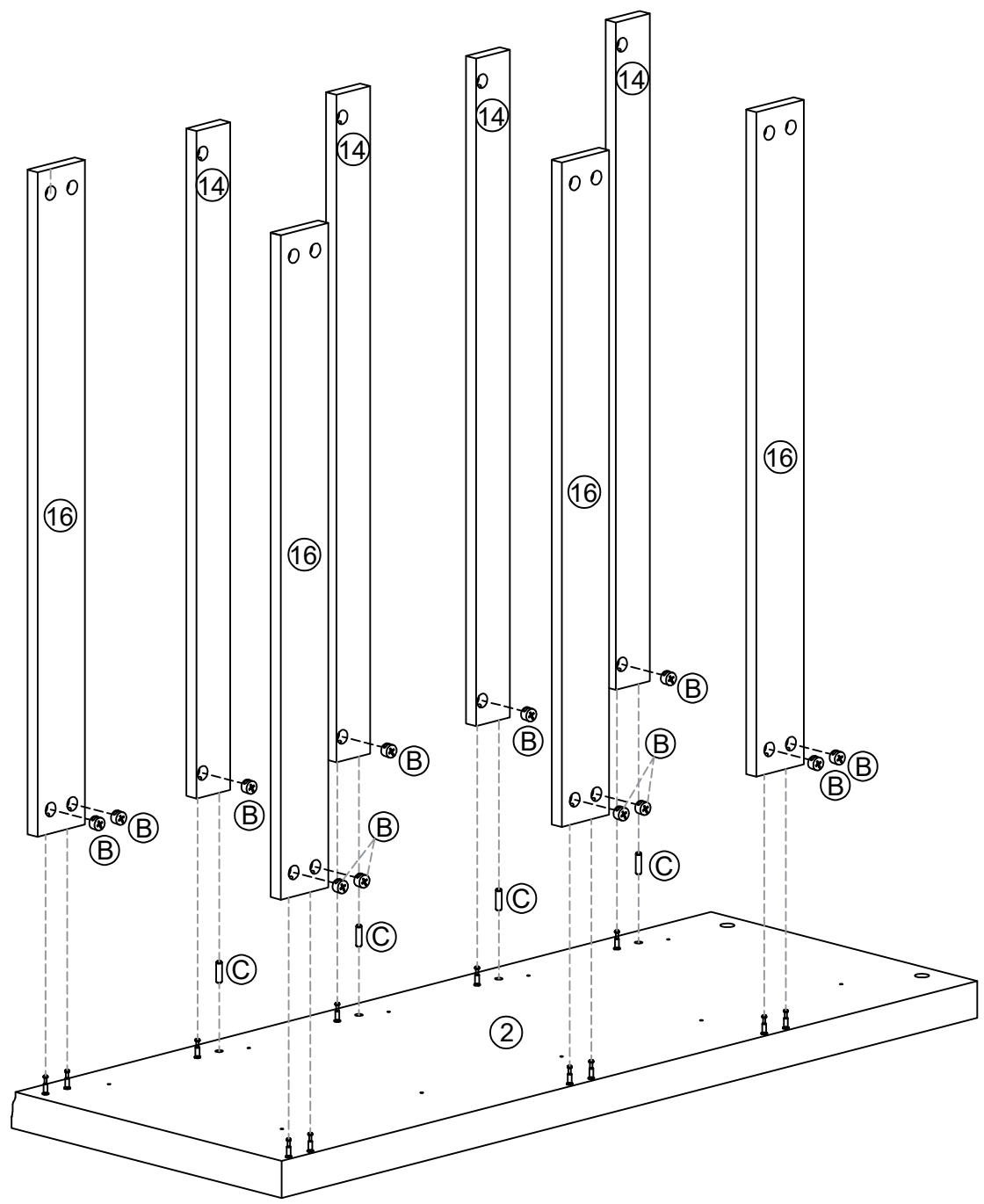
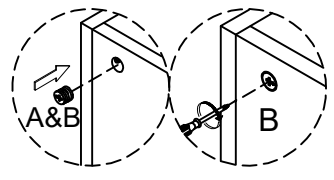
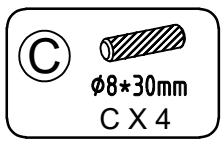
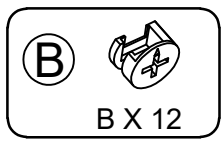

Step 4

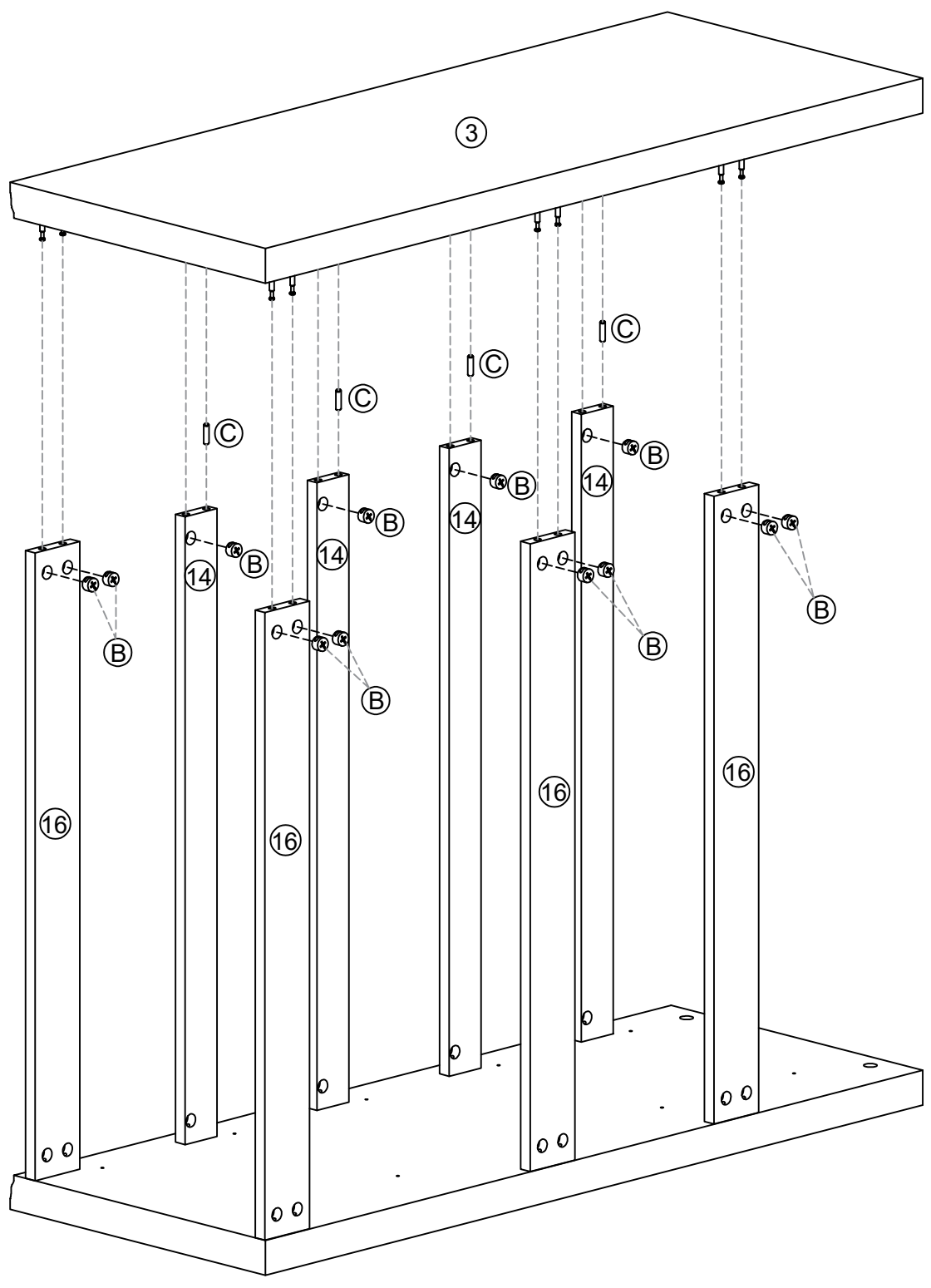
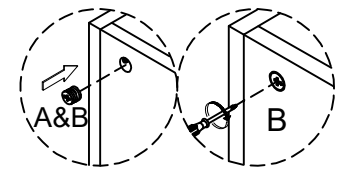
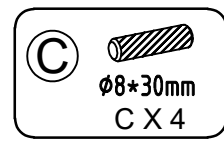
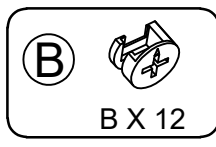

Step 5

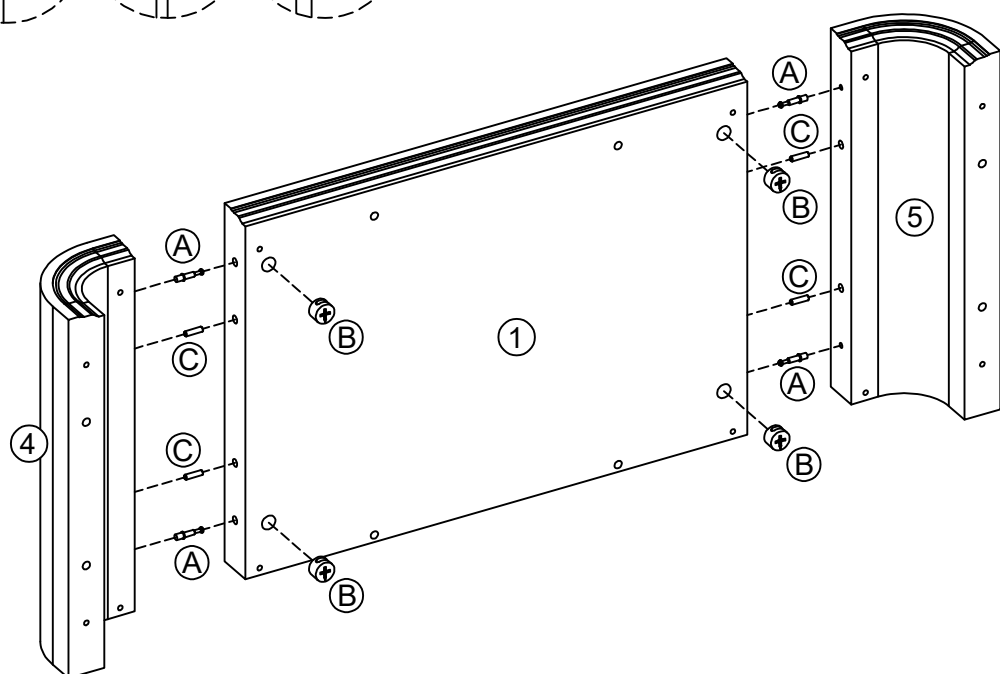
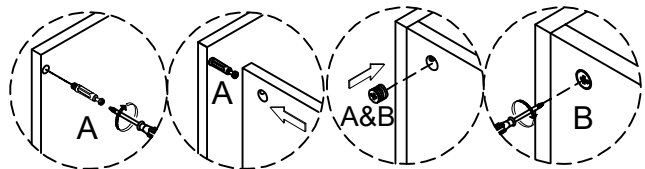
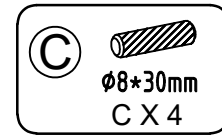
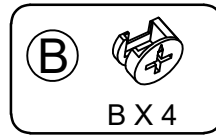
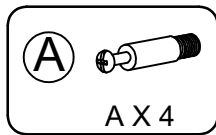

Step 6

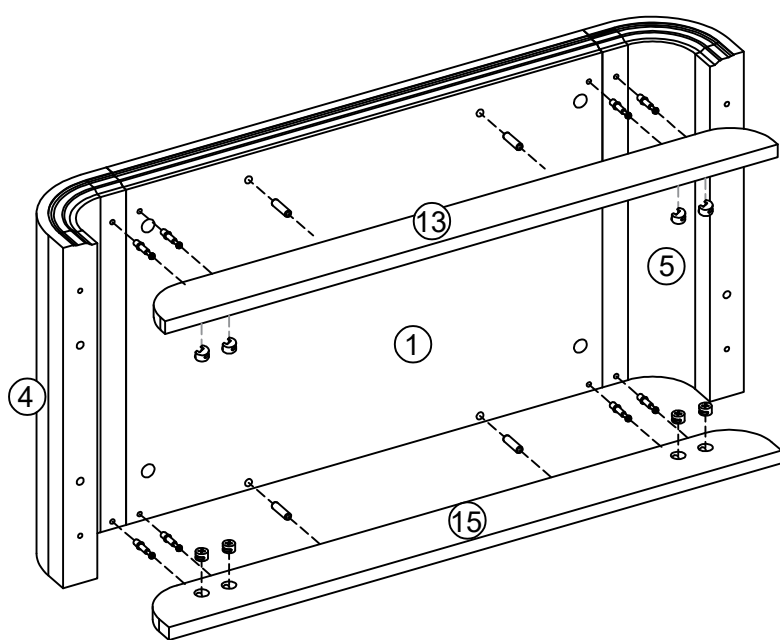
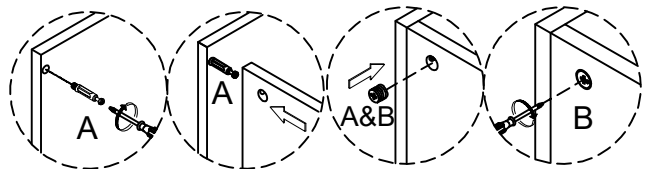
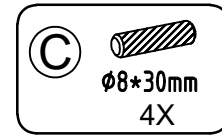
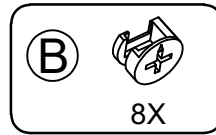
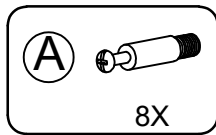

Step 7

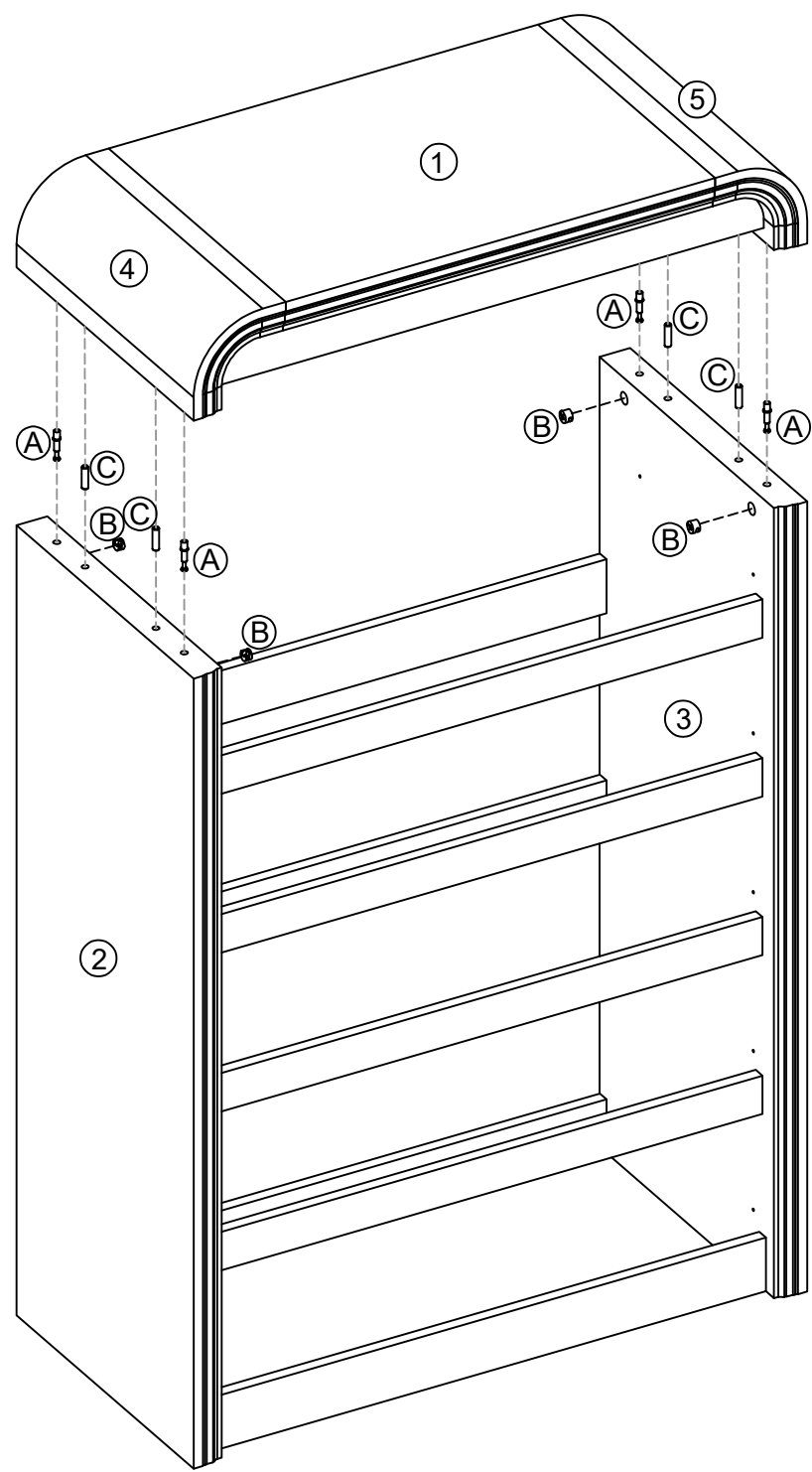
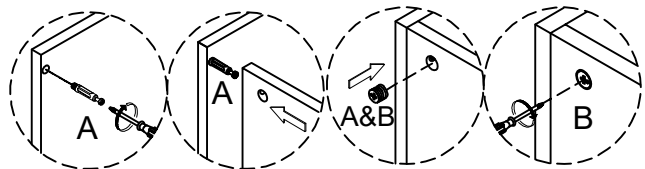
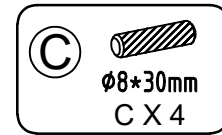
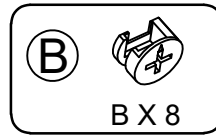
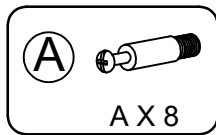

Step 8

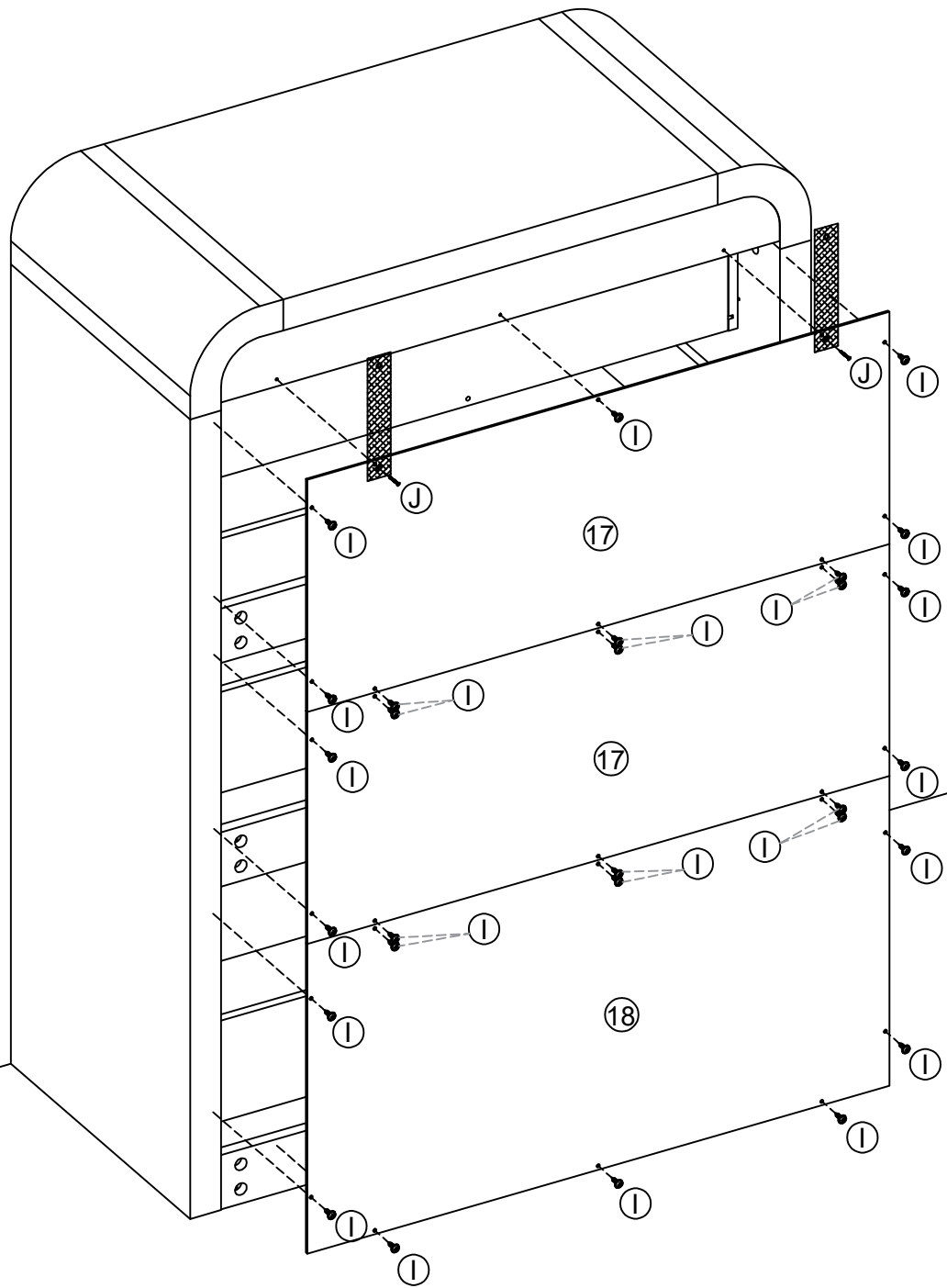
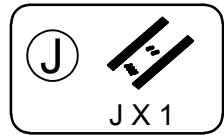
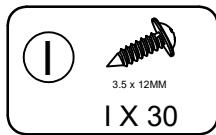

Step 9

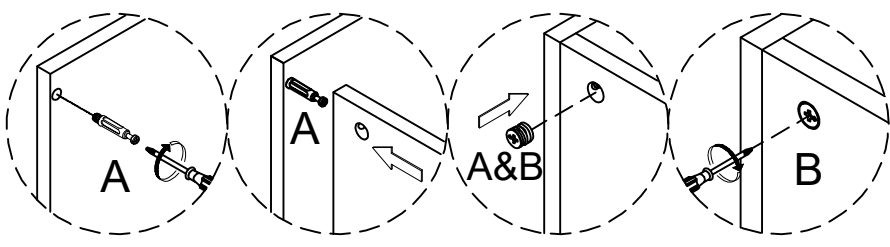
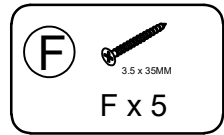
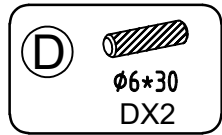
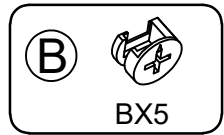
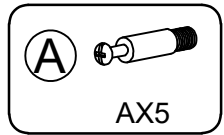

Step:1

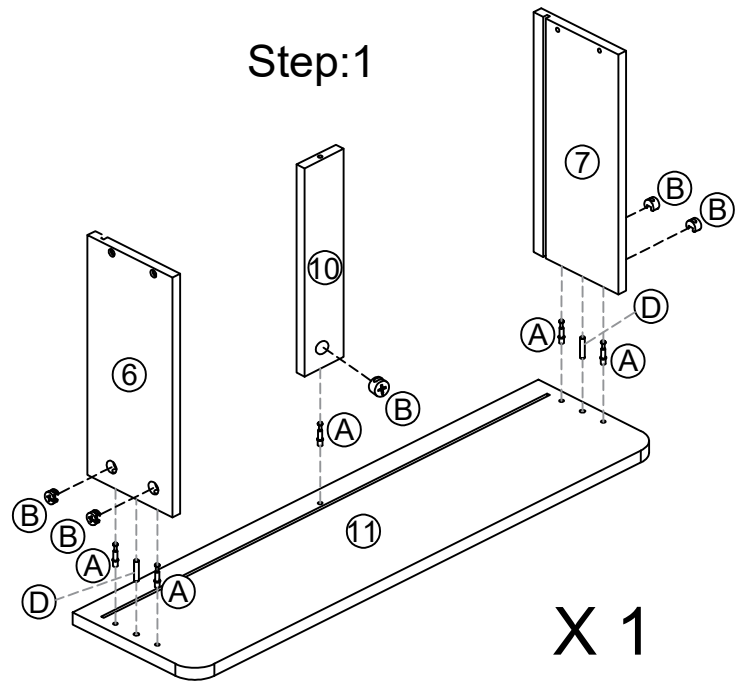

X 1

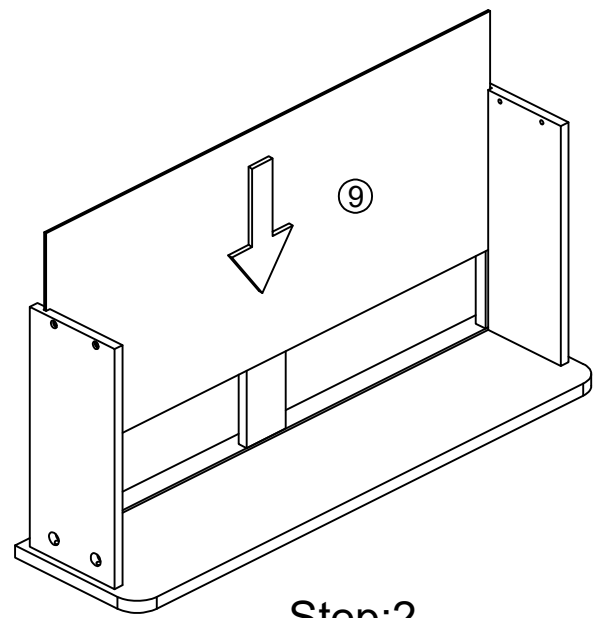

Step:2

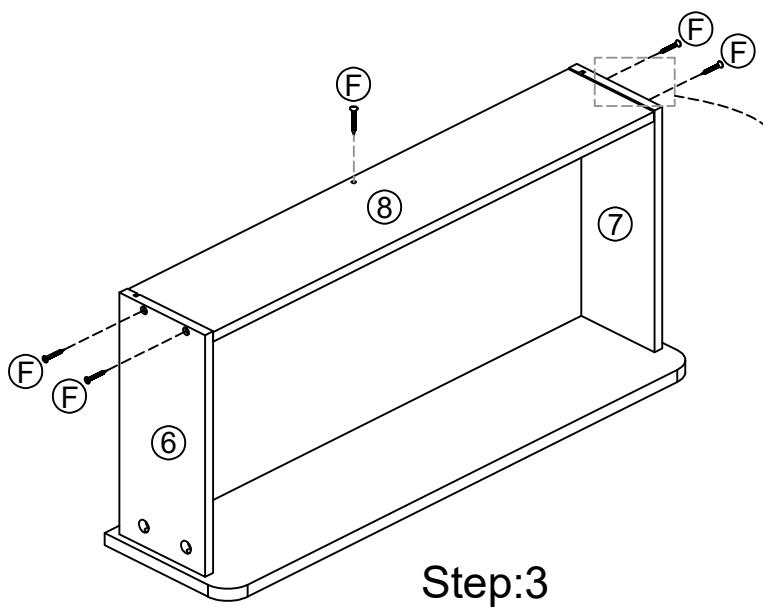

Step:3

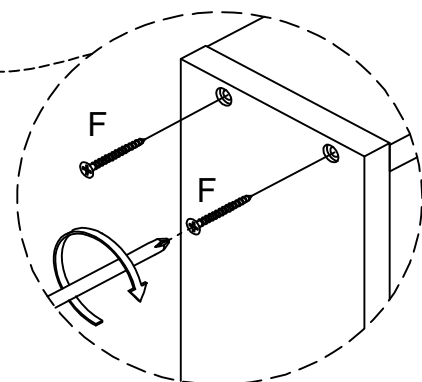

Step 10

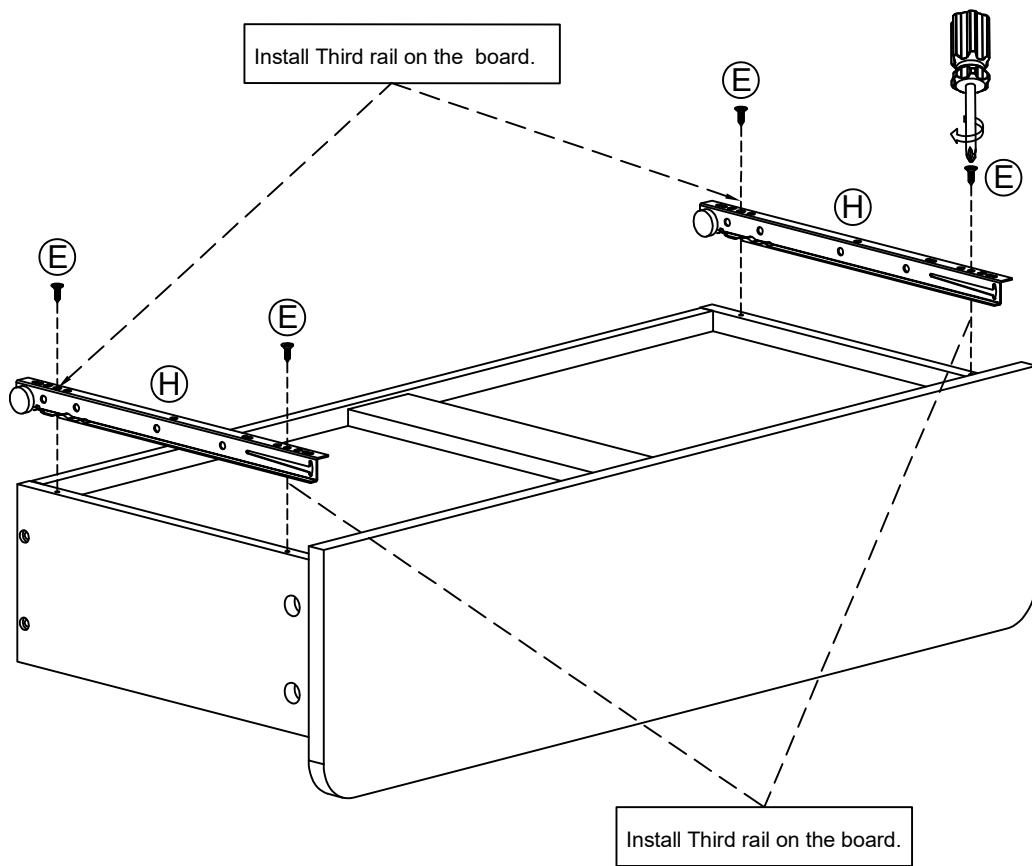
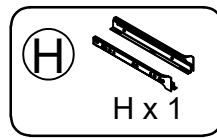
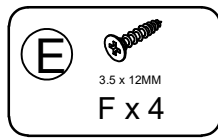

Step 11

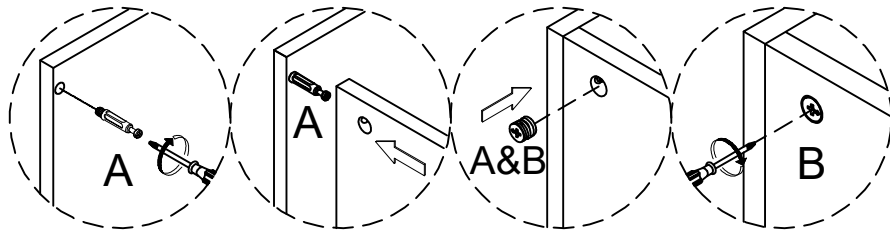
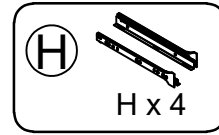
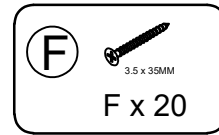
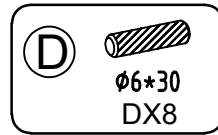
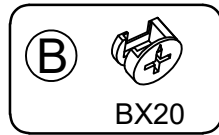
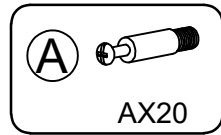

Step:1

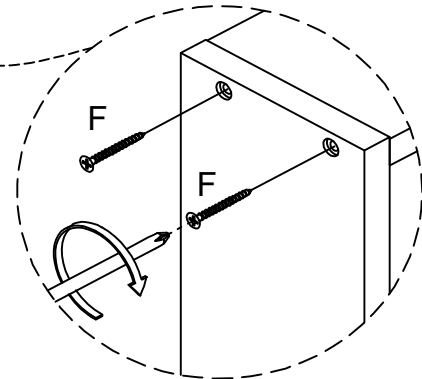
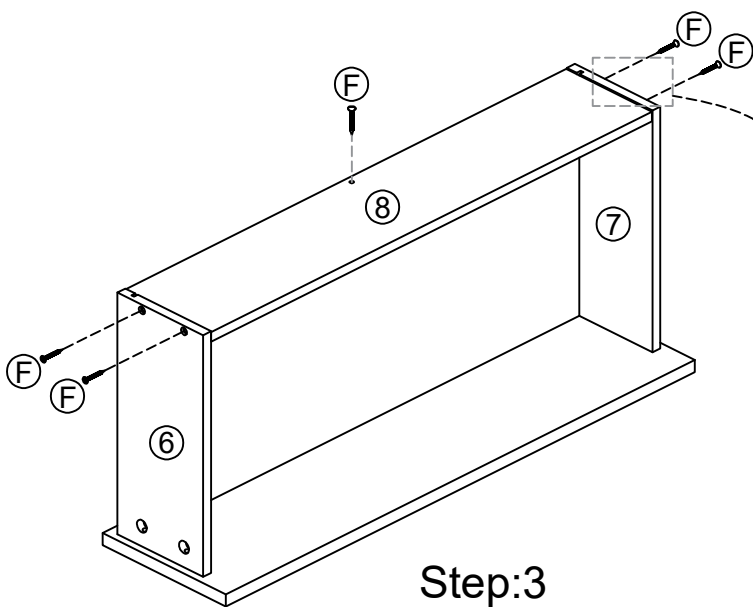
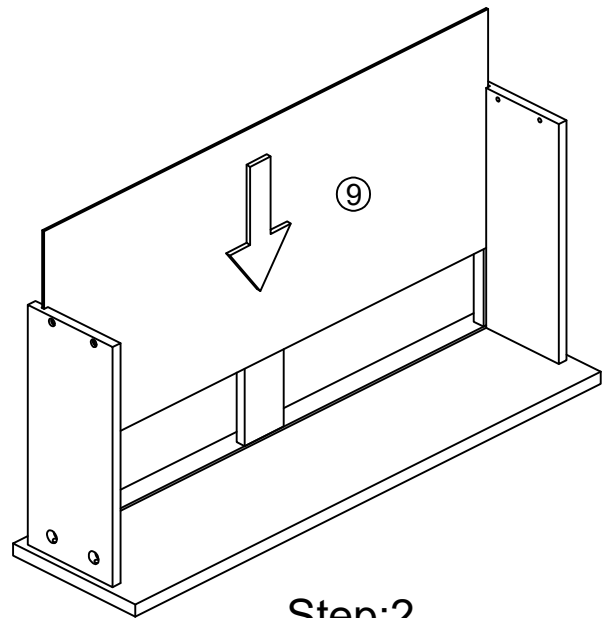
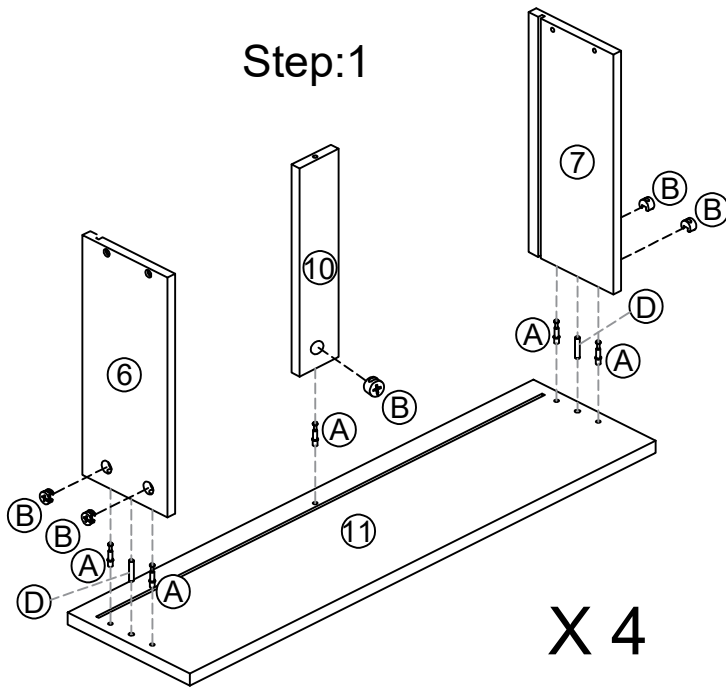

Step 12

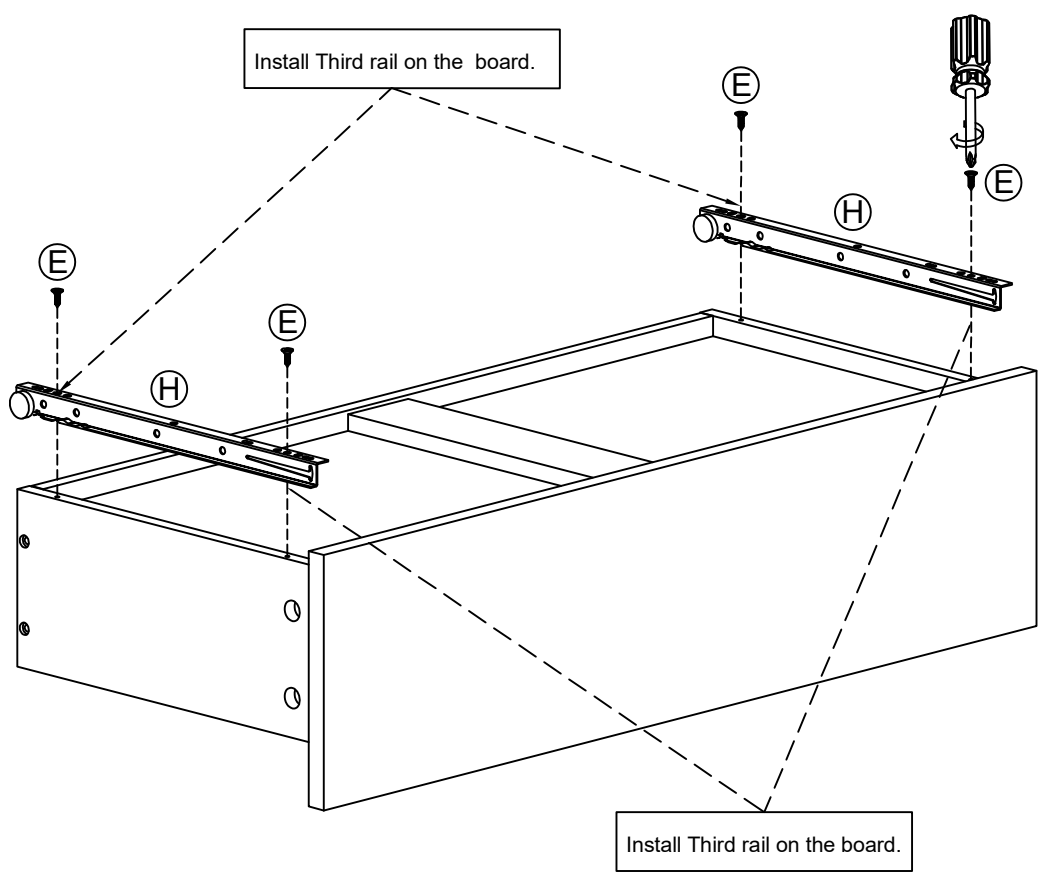
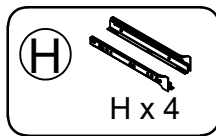
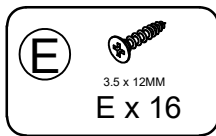

X 4

Step 13

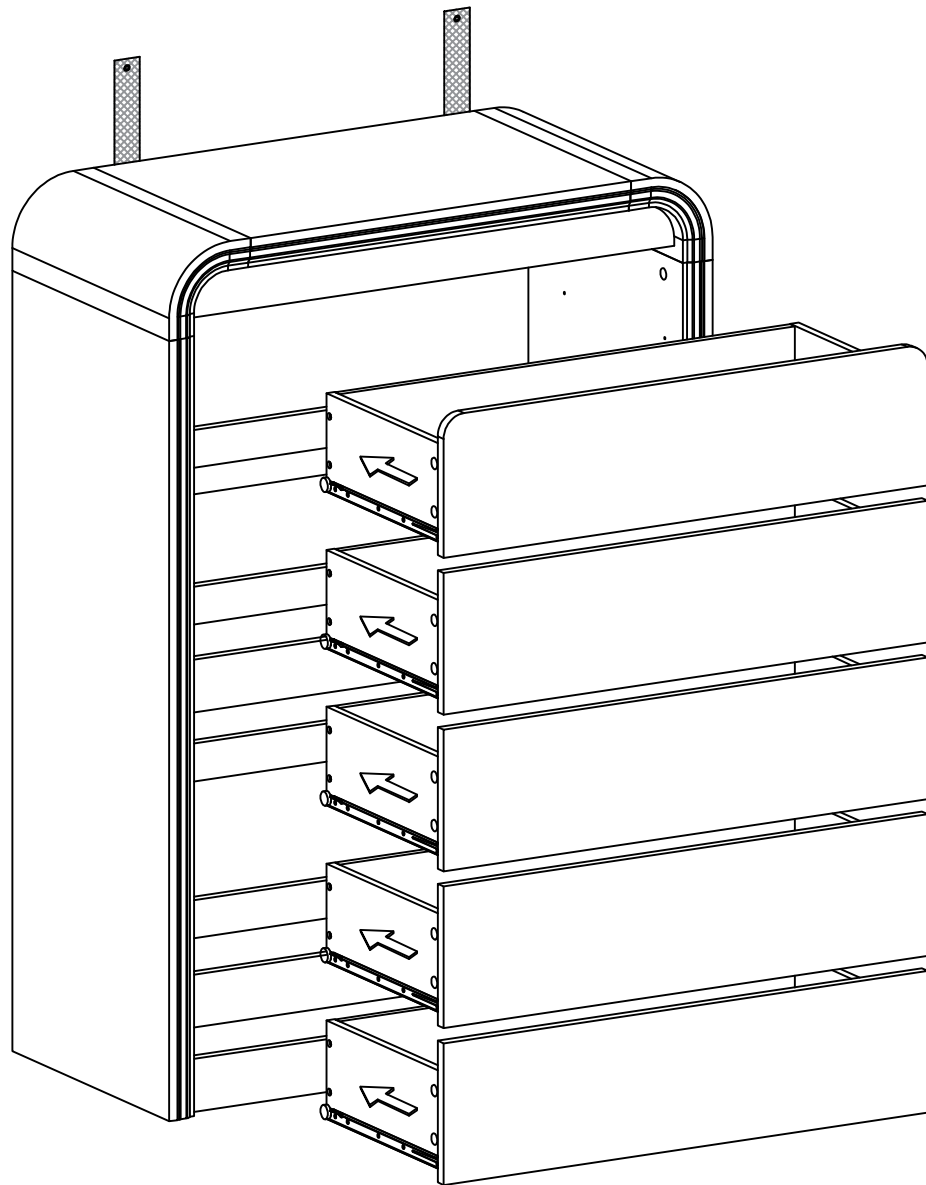

Step 14

