



Manufactured by:  
Backyard Discovery  
3305 Airport Drive, Pittsburg, KS 66762  
800-856-4445

*Basepoint Business Centre: Rivermead Drive, Westlea, Swindon SN5 7EX Phone: 0800-118-2476  
J.P. Coenstraat 7, The Bridge, The Hague, 2595 WP, Netherlands Phone: 08005678990*

# HUTCH / SERVING STATION

**MODEL #: 2304116**



Please visit [www.backyarddiscovery.com](http://www.backyarddiscovery.com)  
For the most up to date assembly manual, to register your product, or to order  
replacement parts Para obtener instrucciones en español, visite  
[www.backyarddiscovery.com](http://www.backyarddiscovery.com)

# OWNER'S MANUAL - BASIC SETUP DIMENSIONS & ASSEMBLY NOTES

- Pay close attention to the items needed for each step. Make sure you are using the correct hardware for each step. Using incorrect hardware may result in improper assembly.

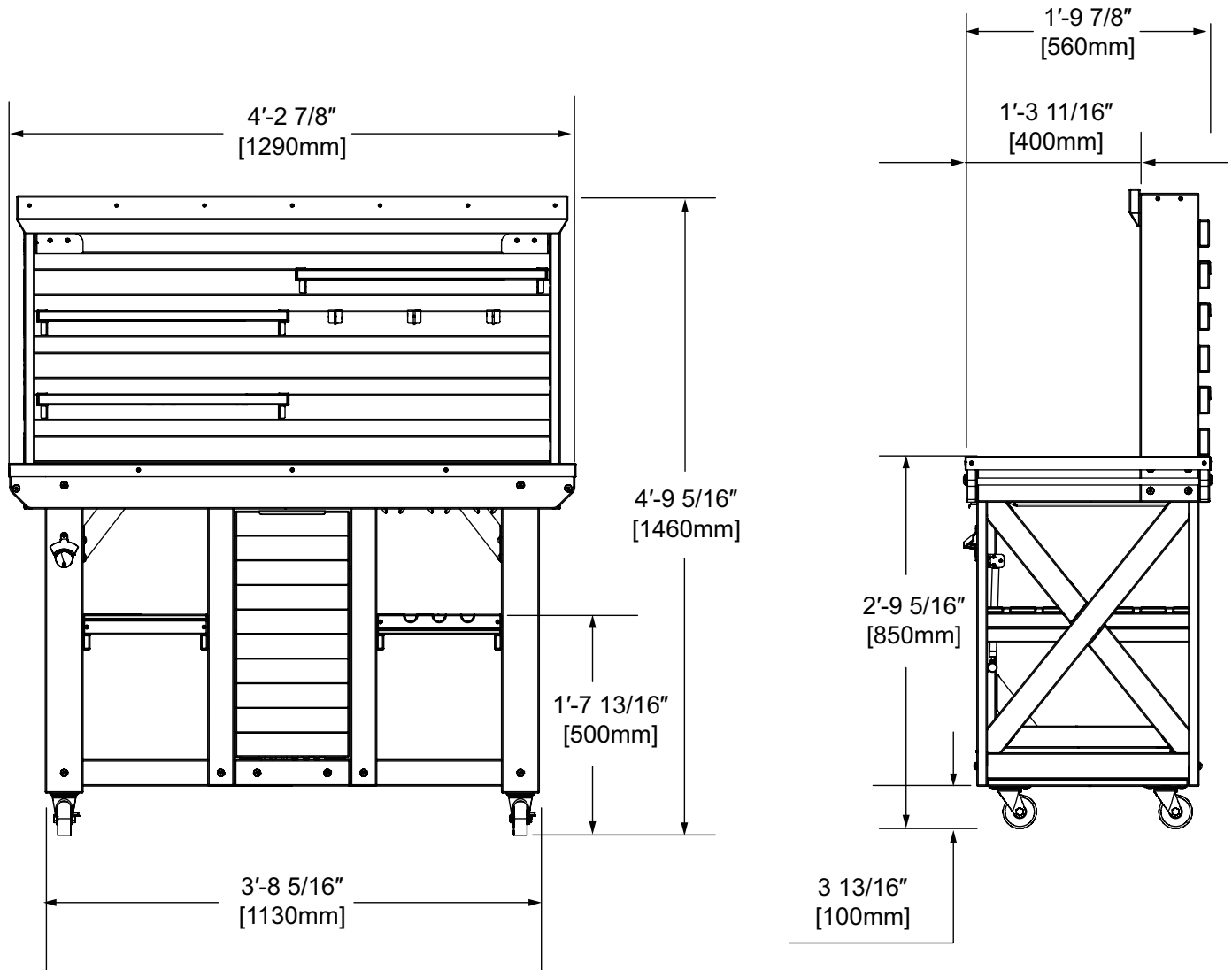

# OWNER'S MANUAL - PARTS IDENTIFICATION

## WOOD COMPONENTS (NOT TO SCALE)



**FL1 - FRONT RIGHT LEG - W2A04482**  
(x1) 15/16"x3 3/8"x29 1/2" (24x86x749)



**FL2 - FRONT LEFT LEG - W2A04483**  
(x1) 15/16"x3 3/8"x29 1/2" (24x86x749)



**CB1 - CROSS BRACE - W4L18892**  
(x2) 15/16"x2 3/8"x29 3/8" (24x60x746)



**TR1 - TABLE BACK LONG RAIL - W4L18894**  
(x1) 15/16"x4"x50 11/16" (24x102x1287)



**TR2 - TABLE FRONT LONG RAIL - W4L18895**  
(x1) 15/16"x4"x50 11/16" (24x102x1287)



**MV1 - MIDDLE LEFT BACK VERTICAL - W4L18896**  
(x1) 15/16"x2 3/8"x27 15/16" (24x60x709)



**MV2 - MIDDLE LEFT FRONT VERTICAL - W4L18897**  
(x1) 15/16"x2 3/8"x27 15/16" (24x60x709)



**DB1 - DRAWER SIDE BOARD - W4L20011**  
(x1) 5/8"x1 15/16"x16 1/2" (16x50x420)



**DB2 - DRAWER BACK BOARD - W4L20012**  
(x1) 5/8"x2 3/8"x9 1/2" (16x60x241)



**TA1 - TABLE SHORT RAIL - W2A04018**  
(x2) 15/16"x4"x19 7/8" (24x102x505)



**BL1 - BACK RIGHT LEG - W2A04484**  
(x1) 15/16"x3 3/8"x29 1/2" (24x86x749)



**BL2 - BACK LEFT LEG - W2A04485**  
(x1) 15/16"x3 3/8"x29 1/2" (24x86x749)

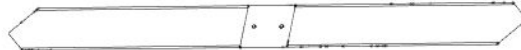

**CB2 - CROSS BRACE - W4L18893**  
(x2) 15/16"x2 3/8"x29 3/8" (24x60x746)



**SB1 - SUPPORT BOARD - W4L18900**  
(x4) 5/8"x1 5/16"x19 15/16" (16x34x506)



**BS3 - TOP MIDDLE SHORT CLEAT - W4L18903**  
(x2) 15/16"x15/16"x19 15/16" (24x24x506)



**MV3 - MIDDLE RIGHT BACK VERTICAL - W4L18898**  
(x1) 15/16"x2 3/8"x27 15/16" (24x60x709)



**MV4 - MIDDLE RIGHT FRONT VERTICAL - W4L18899**  
(x1) 15/16"x2 3/8"x27 15/16" (24x60x709)



**DB3 - DRAWER SIDE BOARD - W4L20013**  
(x1) 5/8"x1 15/16"x16 1/2" (16x50x420)



**BS1 - BOTTOM SLAT - W4L18901**  
(x1) 15/16"x2 3/8"x10 3/8" (24x60x263)



**CB4 - CASTER BOARD - W2A04019**  
(x2) 5/8"x3 3/8"x17 15/16" (16x86x457)

# OWNER'S MANUAL - PARTS IDENTIFICATION

WOOD COMPONENTS (NOT TO SCALE)

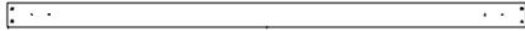

**TS1 - TOP SLAT 1 - W4L18907**  
(x5) 15/16"x2 3/8"x48 1/16" (24x60x1221)

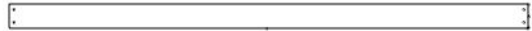

**TS2 - TOP SLAT 2 - W4L18908**  
(x1) 15/16"x2 3/8"x48 1/16" (24x60x1221)

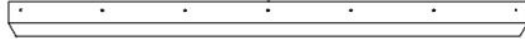

**CB3 - CHAMFERED TOP BOARD - W4L18911**  
(x1) 15/16"x3 3/8"x 49 3/8" (24x86x1255)



**BS4 - CUP HANGER BOARD - W4L18904**  
(x2) 15/16"x15/16"x13 7/8" (24x24x352)



**BH1 - BOTTLE HOLD BOARD - W4L21182**  
(x2) 5/8"x2 3/8"x9 15/16" (16x60x250)



**SB2 - SHELF BOARD - W4L18910**  
(x3) 15/16"x5 1/4"x22 7/16" (24x134x570)



**BS5 - BACK LEFT SHELF UPRIGHT - W4L18905**  
(x1) 15/16"x5 1/4"x27 11/16" (24x134x703)



**BS6 - BACK RIGHT SHELF UPRIGHT - W4L18906**  
(x1) 15/16"x5 1/4"x27 11/16" (24x134x703)

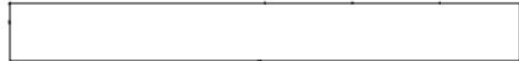

**TS3 TOP SHELF BOARD - W4L18909**  
(x1) 15/16"x5 1/4"x48 3/16" (24x134x1173)

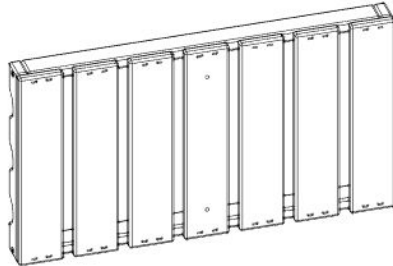

**WR1 - WINE RACK ASSY - W2A04016**  
(x2) 1 13/16"x11 1/8"x19 15/16" (46x283x506)

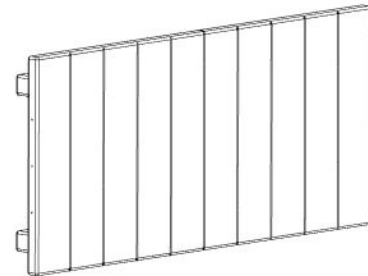

**DA1 - DRAWER ASSY - W2A04017**  
(x1) 1 9/16"x10 3/16"x22 1/16" (40x259x560)

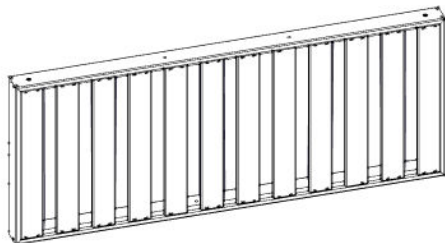

**BP1 - BOTTOM PANEL - W2A04015**  
(x1) 2 3/8"x18"x44 5/16" (60x458x1125)

# OWNER'S MANUAL - PARTS IDENTIFICATION

## METAL COMPONENTS (NOT TO SCALE)

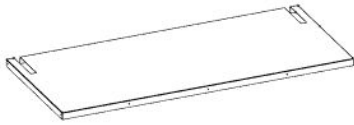

**TABLE - A4M02543**  
(x1)



**HANGER TUBE - A4M02541**  
(x1)

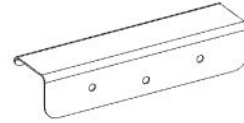

**HANDLE - A4M02550**  
(x1)



**CASTER - A4M02605**  
(x4)



**TOWEL BAR - A4M02542**  
(x2)



**TRASH CAN DOOR CHAIN - A4M04127**  
(x2)

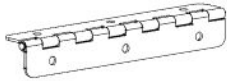

**PIANO HINGE - A4M02549**  
(x1)



**TRASH SUPPORT - A4M02554**  
(x1)

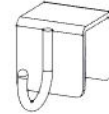

**HOOK - A4M02548**  
(x3)



**METAL BRACKET - A4M02540**  
(x6)

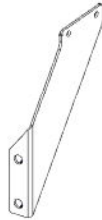

**METAL ANGLE BRACE LEFT - A4M02539**  
(x2)



**METAL ANGLE BRACE RIGHT - A4M02538**  
(x2)



**BOTTLE CAP OPENER - A4M01187**  
(x1)

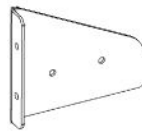

**METAL ANGLE TOP BRACE LEFT - A4M02544**  
(x1)

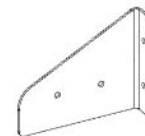

**METAL ANGLE TOP BRACE RIGHT - A4M02545**  
(x1)



**BYD ID TAG PATIO - A4M02158**  
(x1)

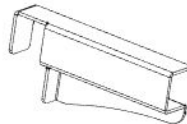

**SHELF SUPPORT LEFT - A4M02547**  
(x3)

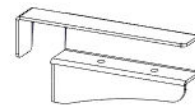

**SHELF SUPPORT RIGHT - A4M02546**  
(x3)



**TRASH SUPPORT - A4M02553**  
(x4)

# OWNER'S MANUAL - PARTS IDENTIFICATION

## HARDWARE COMPONENTS (NOT TO SCALE)

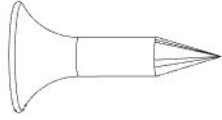

**H100411 SCREW PFH**  
**(x12) 8x5/8 BLK**



**H100823 SCREW PWH**  
**(x7) 8X1 1/2 BLK**



**H100382 SCREW PFH**  
**(x40) 8x1-3/4 BLK**

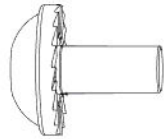

**H100401 BOLT WH**  
**(x16) 1/4x1/2 BLK**



**H100835 SCREW PWH**  
**(x12) 8X2 BLK**

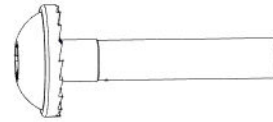

**H100397 BOLT WH**  
**(x6) 1/4x1-1/4 BLK**

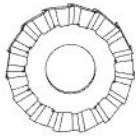

**H100405 WASHER LOCK EXT**  
**(x36) 6x15 BLK**

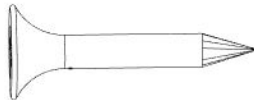

**H100816 SCREW PFH**  
**(x10) 8x7/8 BLK**



**H100387 SCREW PFH**  
**(x10) 8x1-1/4 BLK**

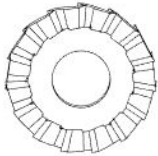

**H100400 WASHER LOCK EXT**  
**(x14) 8x15 BLK**

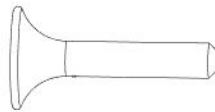

**H101296 SCREW PFH-BLUNT TIP**  
**(x6) 6x1/2**



**H100399 NUT BARREL WH**  
**(x14) 1/4 X 7/8 BLK**



**H100406 BOLT WH**  
**(x30) 1/4x1 1/2 BLK (Lag)**

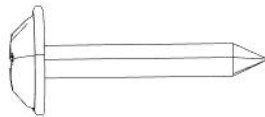

**H100392 SCREW PWH**  
**(x44) 8x3/4 BLK**



**H101069 SCREW PWH**  
**(x6) 8X7/8 BLK**

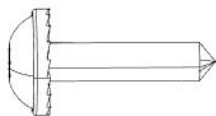

**H100460 LAG SCREW WH**  
**(x8) 1/4x1 BLK**

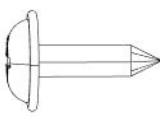

**H100408 SCREW PWH**  
**(x15) 8x1/2 BLK**

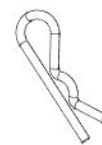

**COTTER PIN - H101161**  
**(x4)**



**H101100 MAGNETIC DRIVER**  
**(x1)**



**H100147 T-30 TORX BIT**  
**(x1)**

**H100114 T-30 TORX WRENCH**  
**(x1)**



# PRE-ASSEMBLY STEP 1 - SORTING PARTS

It is critical for ease of assembly that you take the time to sort and organize the wood and hardware.

---

## WOOD PARTS:

- Organize wood parts by the three-digit, alpha-numeric number stamped on each board (ex. P01).
- If there are multiple boards with the same stamped number, stack those pieces together.
- Stamps can be found on the flat surface of the boards or on the end of the boards.
- Allow yourself plenty of room - the wood pieces can take up a significant amount of space.

**NOTE: CARTONS ARE NOT ORGANIZED BY BOARD OR STEP NUMBER.**



---

## HARDWARE PARTS:

- We recommend that you have a separate table to organize the hardware.
- Hardware bags are printed with a seven-digit, alpha-numeric part number.
- You can organize your hardware by part number or group by hardware type (e.g. bolts, nuts, etc.).
- During assembly you only need to reference the last four digits of the number.

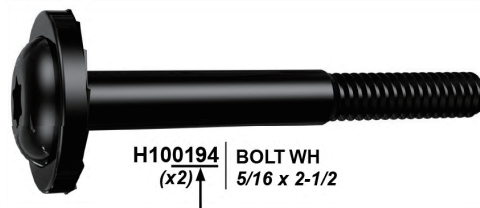

# PRE-ASSEMBLY STEP 2 - TOOLS REQUIRED



Cordless Drill or  
Electric Drill



Drill Attachments:  
Phillips Head



1/8", 3/16", 3/8" &  
7/16" Drill Bits



Phillips Screw Driver

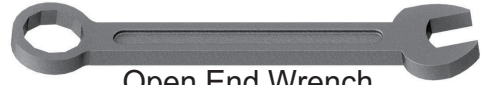

Open End Wrench  
7/16"



3/8" Drive Ratchet, 1/2" &  
7/16" STD Sockets 1/2" & 7/16"  
Deep Sockets



Claw Hammer

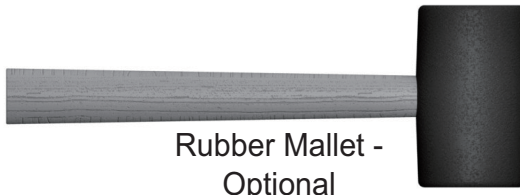

Rubber Mallet -  
Optional

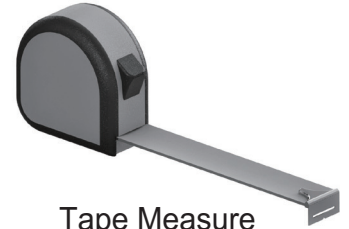

Tape Measure

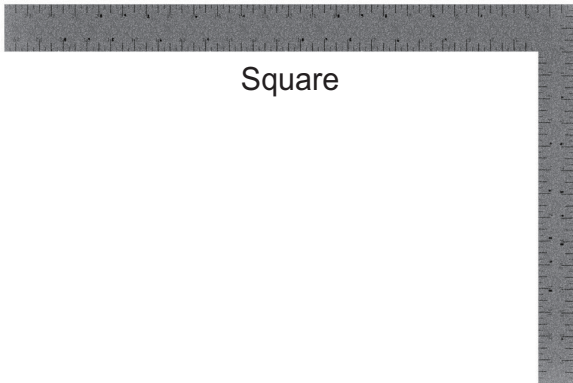

Square



Level 24"

# STEP 1A - LEG AND CROSS BRACE ASSEMBLY

Qty	Part No	Description
4	H100835	SCREW PWH 8X2 BLK

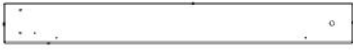

FL1- FRONT RIGHT LEG - W2A04482  
(x1) 15/16"x3 3/8"x29 1/2" (24x86x749)



BL1- BACK RIGHT LEG - W2A04484  
(x1) 15/16"x3 3/8"x29 1/2" (24x86x749)



FL2- FRONT LEFT LEG - W2A04483  
(x1) 15/16"x3 3/8"x29 1/2" (24x86x749)



BL2- BACK LEFT LEG - W2A04485  
(x1) 15/16"x3 3/8"x29 1/2" (24x86x749)

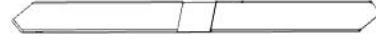

CB1- CROSS BRACE - W4L18892  
(x2) 15/16"x2 3/8"x29 3/8" (24x60x746)

- BE SURE TO MATCH CB1 WITH FL1 / BL1 AND FL2 / BL2.
- ALIGN CB1 WITH PILOT HOLES IN LEGS FL1 / BL1 AND FL2 / BL2.
- INSERT SCREWS.
- PLACE LEGS AND CROSS BRACE ON A FLAT SURFACE. TOP AND BOTTOM OF EACH LEG SHOULD BE ALONG THE SAME PLANE.

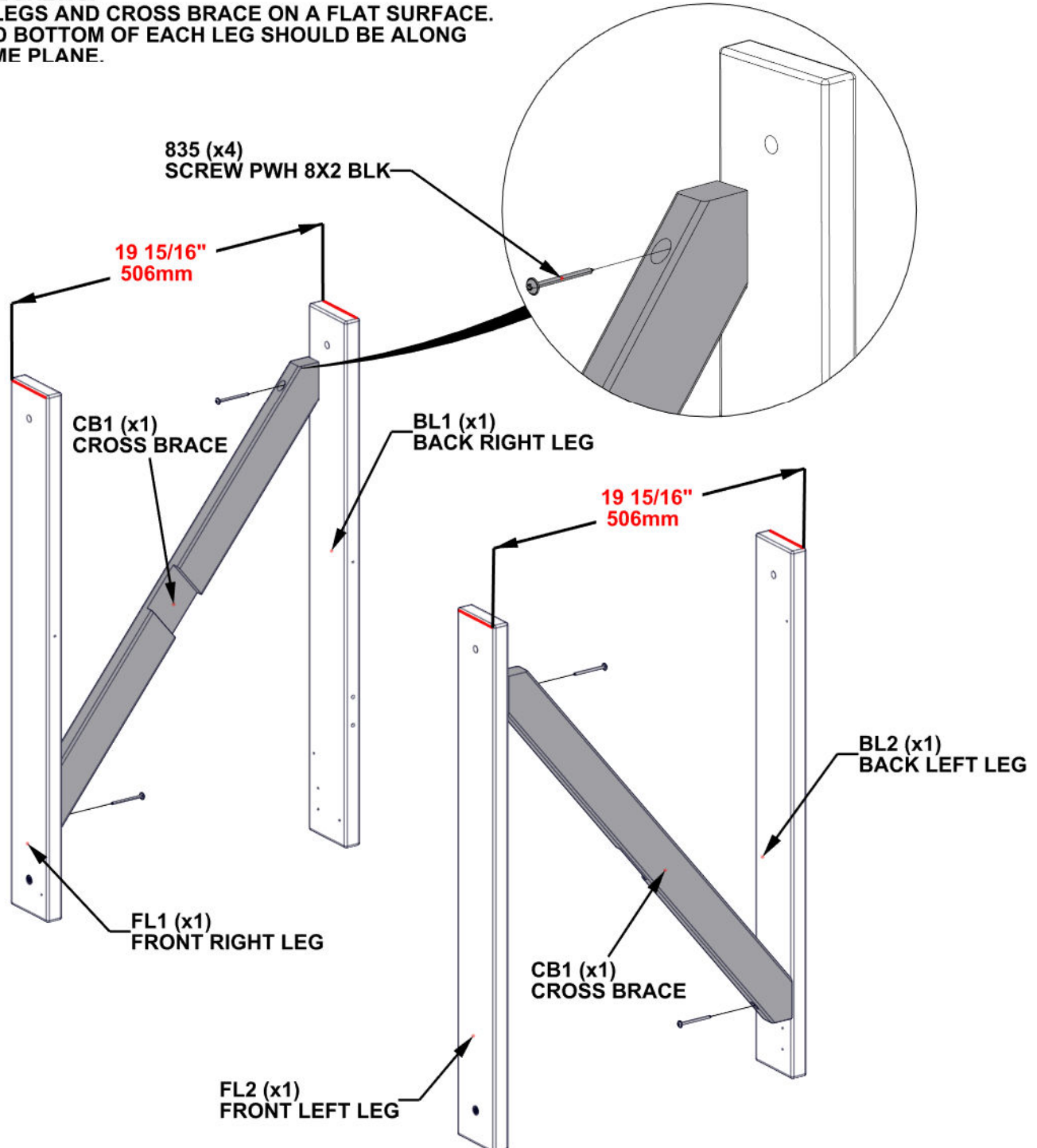

# STEP 1B - LEG AND CROSS BRACE ASSEMBLY

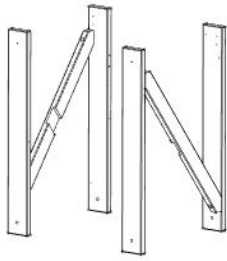

LEG AND CROSS BRACE ASSEMBLY - STEP - 1A

Qty	Part No	Description
4	H100816	SCREW PFH 8x7/8 BLK
4	H100835	SCREW PWH 8x2 BLK

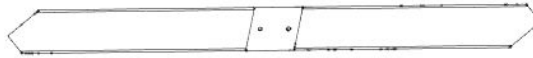

CB2 - CROSS BRACE - W4L18893  
(x2) 15/16"x2 3/8"x29 3/8" (24x60x746)

- ALIGN CB2 WITH PILOT HOLES IN LEGS OF ASSEMBLY FROM STEP 1A.
- INSERT SCREWS.
- PLACE LEGS AND CROSS BRACE ON A FLAT SURFACE.
- TOP AND BOTTOM OF EACH LEG SHOULD BE ALONG THE SAME PLANE.

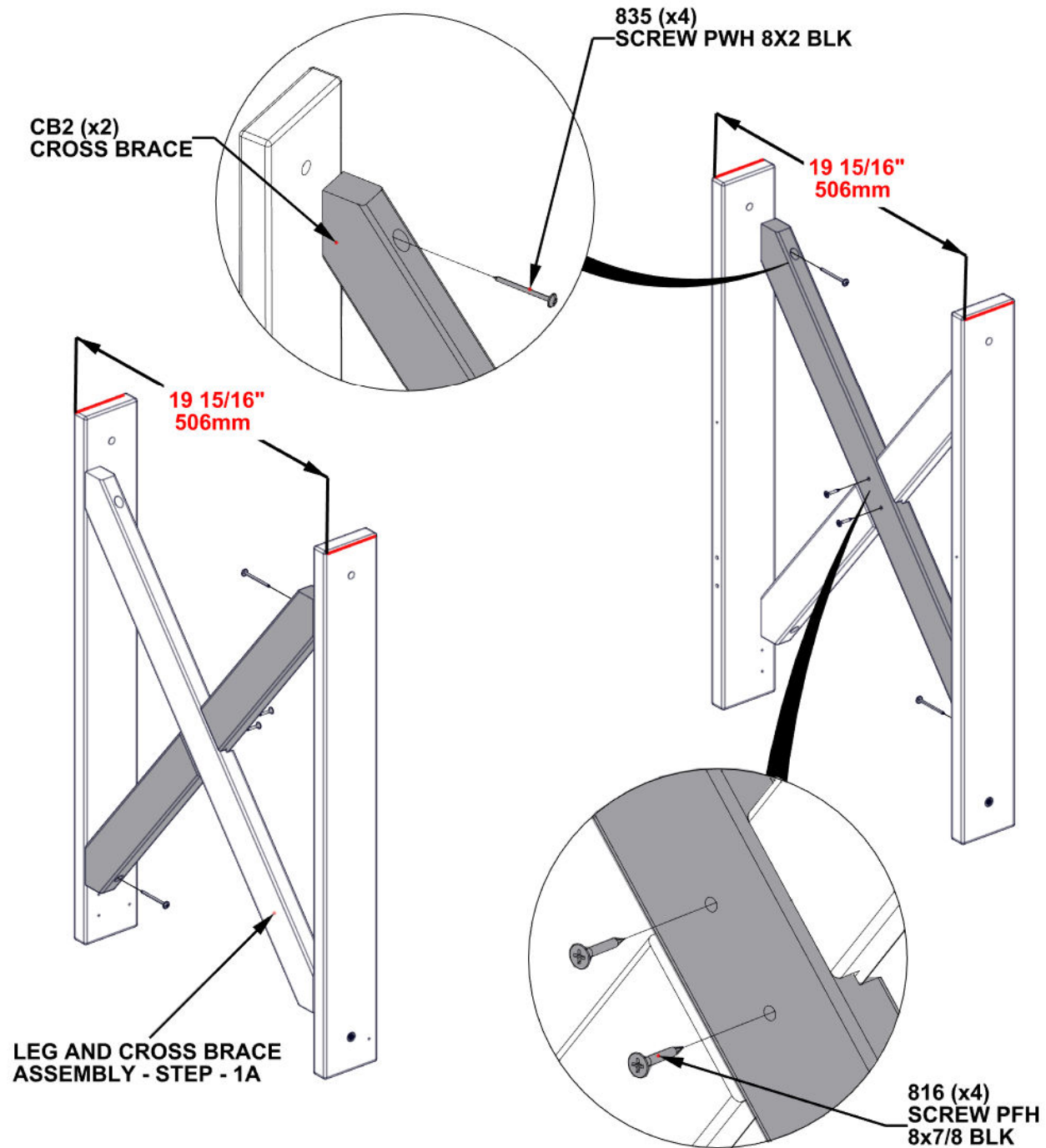

# STEP 2 - BOTTOM PANEL ASSEMBLY

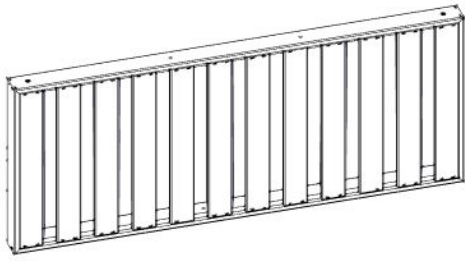

**BP1 - BOTTOM PANEL - W2A04015**  
 (x1) 2 3/8"x18"x44 5/16" (60x458x1125)

Qty	Part No	Description
4	H100405	WASHER LOCKEXT 6X15 BLK
4	H100406	BOLT WH 1/4x1 1/2 BLK

**SQUARE BOTTOM PANEL ASSEMBLY TO EACH LEG BEFORE TIGHTENING.**

**PILOT HOLES FACE UP ON THE PANEL.**

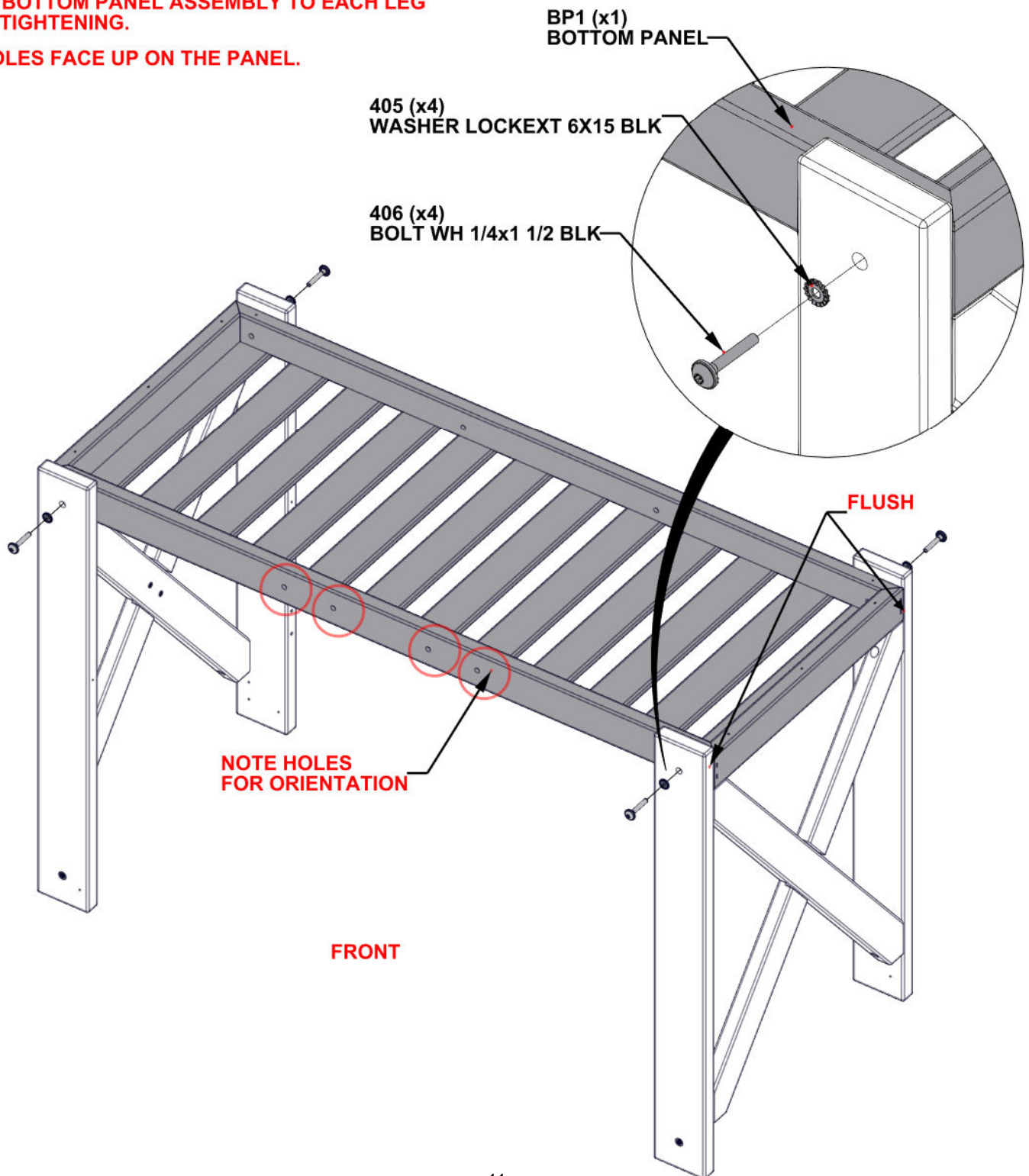

# STEP 3 - CASTER BOARD ASSEMBLY

Qty	Part No	Description
10	H100387	SCREW PFH 8x1-1/4 BLK



CB4 - CASTER BOARD - W2A04019  
(x2) 5/8"x3 3/8"x17 15/16" (16x86x457)

- ALIGN PILOT HOLES.

**NOTE THREADED INSERTS FOR ORIENTATION.**

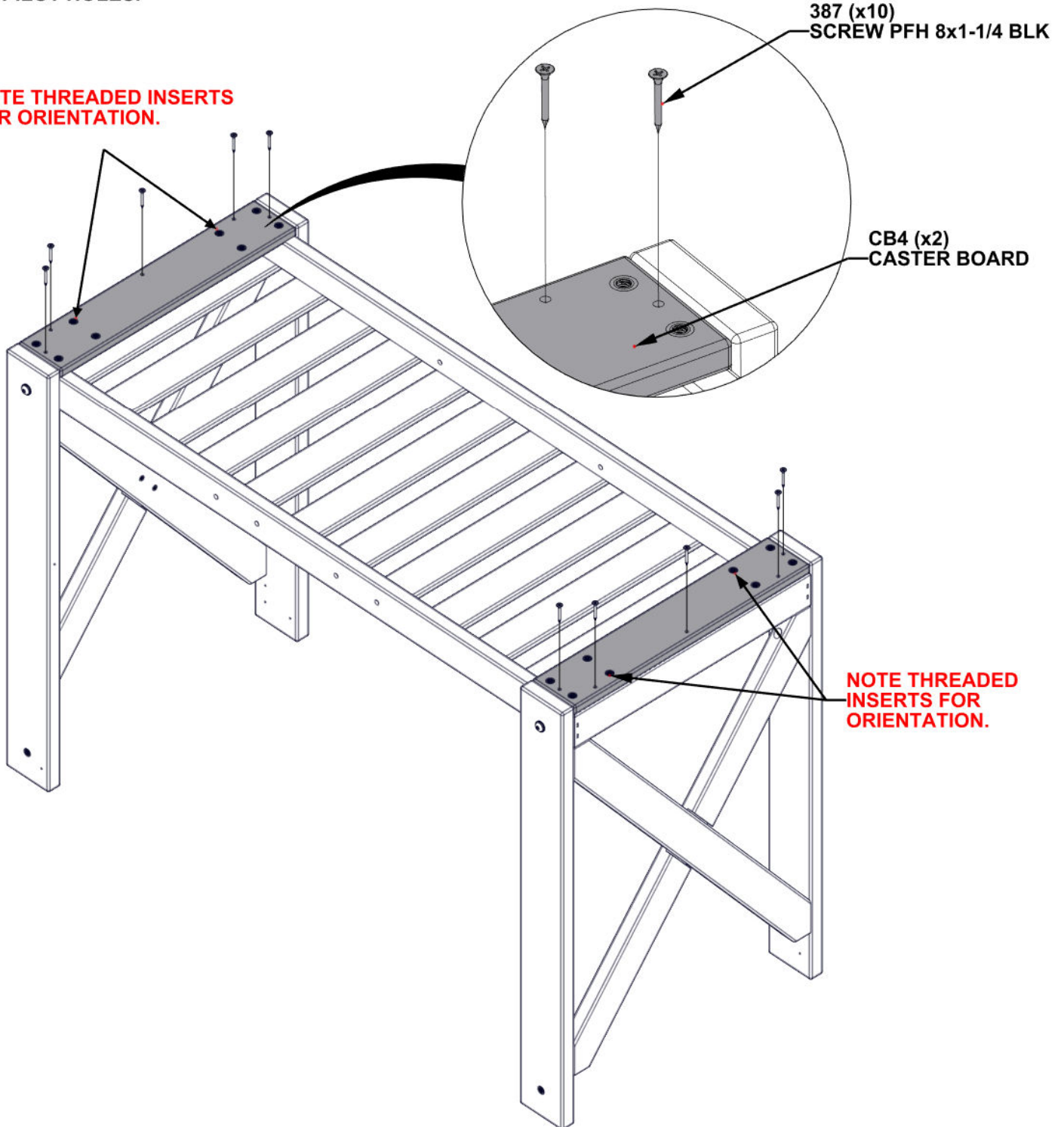

**NOTE THREADED INSERTS FOR ORIENTATION.**

# STEP 4 - CASTER ASSEMBLY

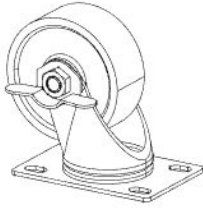

**CASTER - A4M02605  
(x4)**

Qty	Part No	Description
16	H100401	BOLT WH 1/4x1/2 BLK

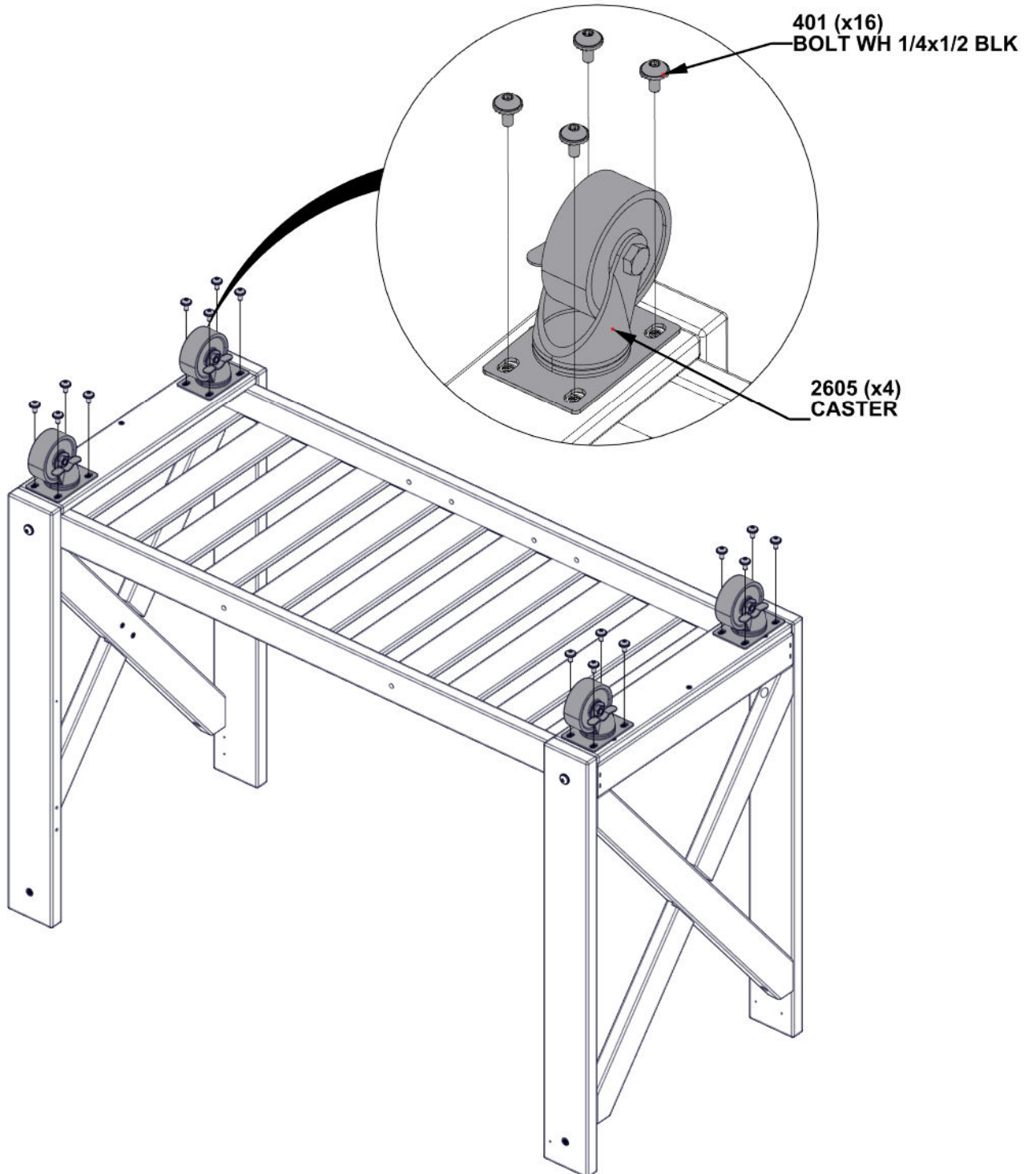

# STEP 5 - TABLE LONG RAIL ASSEMBLY



TR1 - TABLE BACK LONG RAIL - W4L18894  
(x1) 15/16"x4"x50 11/16" (24x102x1287)



TR2 - TABLE FRONT LONG RAIL - W4L18895  
(x1) 15/16"x4"x50 11/16" (24x102x1287)

Qty	Part No	Description
4	H100405	WASHER LOCK EXT 6X15 BLK
4	H100406	BOLT WH 1/4x1 1/2 BLK

- ALIGN PILOT HOLES.

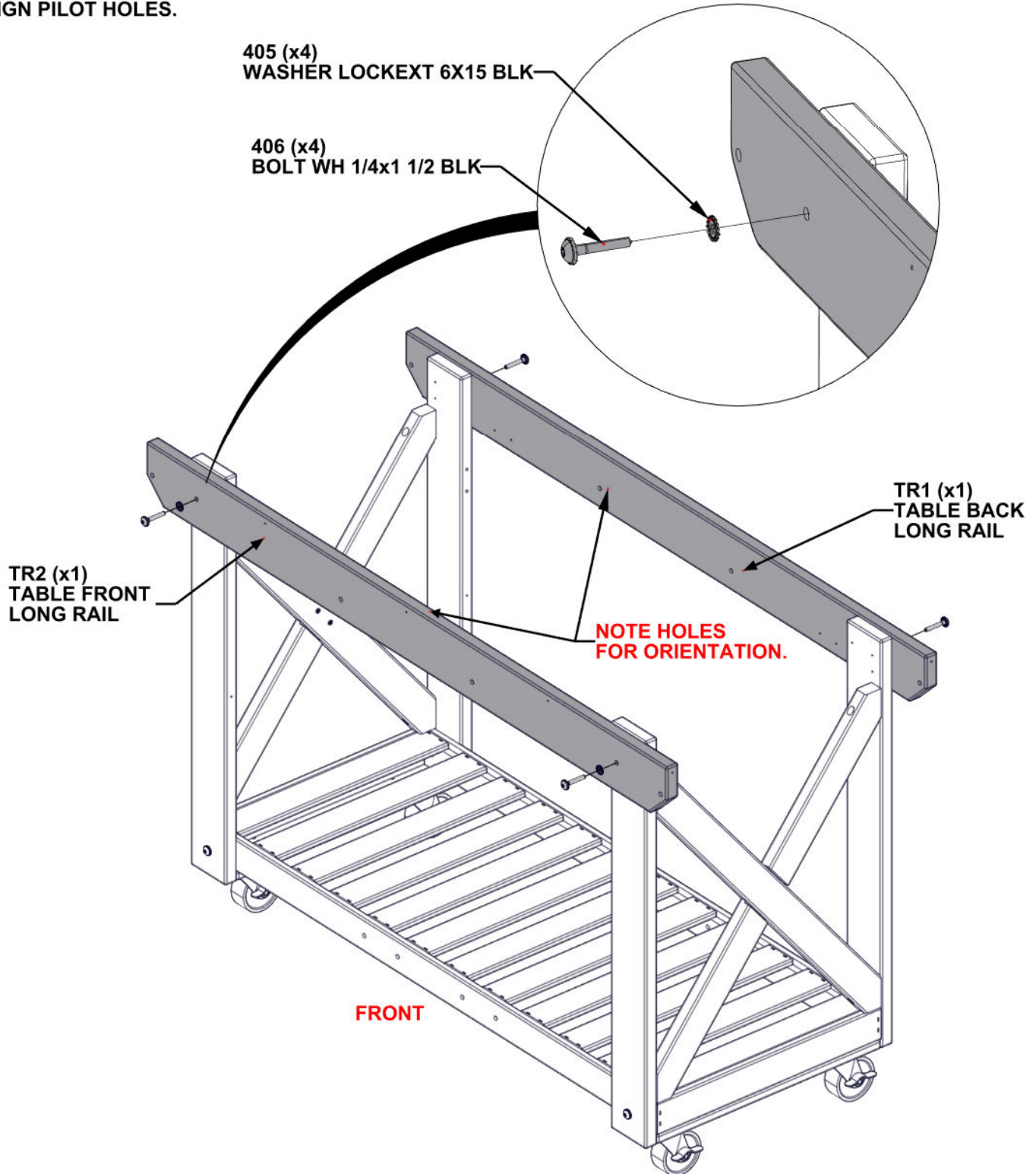

# STEP 6 - METAL ANGLE BRACE ASSEMBLY

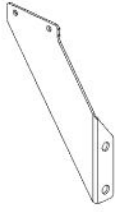

Qty	Part No	Description
4	H100392	SCREW PWH 8X3/4 BLK
4	H100460	LAG SCREW WH 1/4 X 1 BLK

METAL ANGLE BRACE LEFT- A4M02539 (x1)

METAL ANGLE BRACE RIGHT- A4M02538 (x1)

- ALIGN PILOT HOLES.

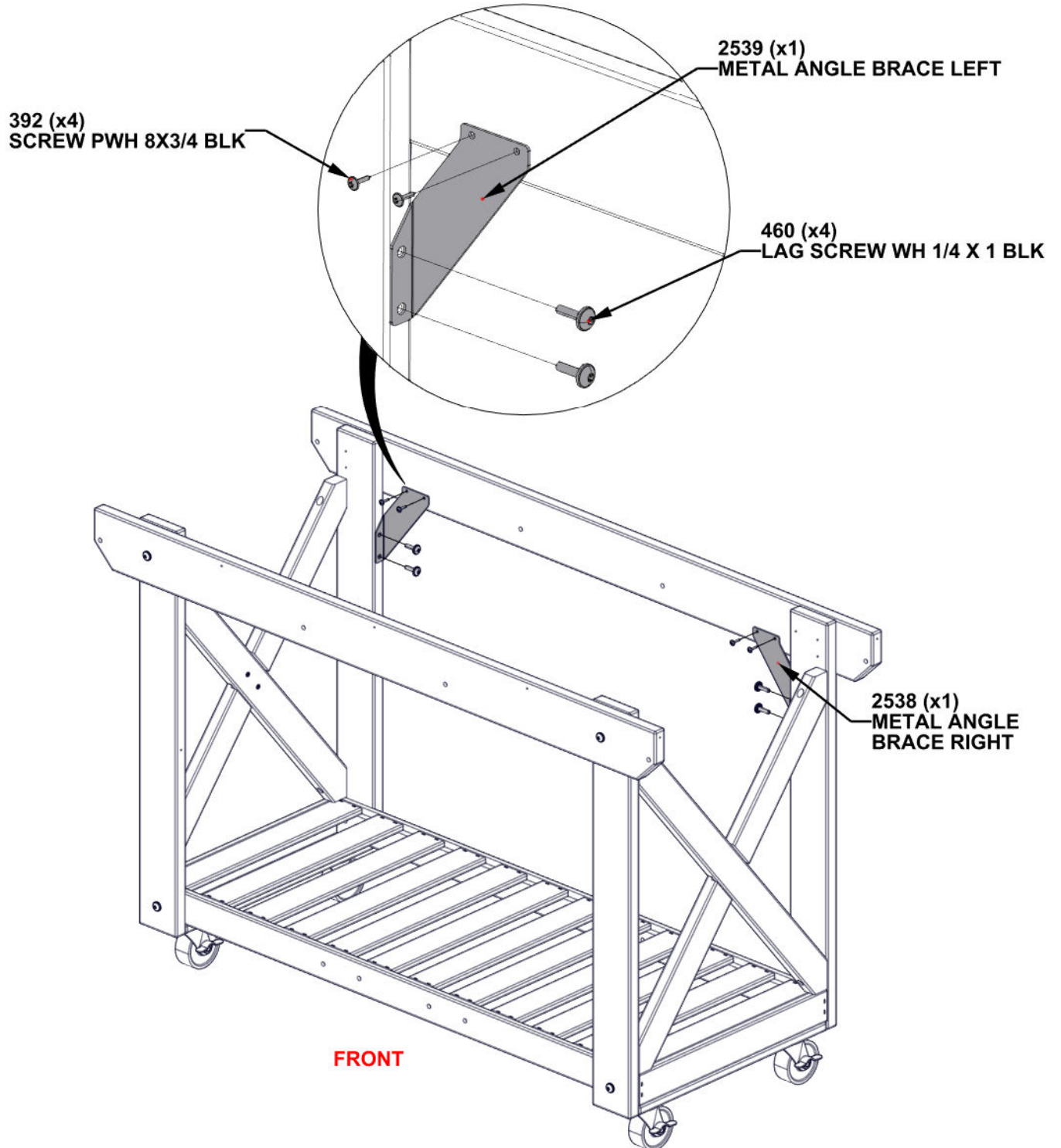

# STEP 7A - MIDDLE VERTICAL ASSEMBLY

Qty	Part No	Description
4	H100399	NUT BARRELL WH 1/4 X 7/8 BLK
4	H100400	WASHER LOCKEXT 8X15 BLK
4	H100405	WASHER LOCKEXT 6X15 BLK
4	H100406	BOLT WH 1/4x1 1/2 BLK



MV1 - MIDDLE LEFT BACK VERTICAL - W4L18896  
(x1) 15/16"x2 3/8"x27 15/16" (24x60x709)



MV3 - MIDDLE RIGHT BACK VERTICAL - W4L18898  
(x1) 15/16"x2 3/8"x27 15/16" (24x60x709)



MV2 - MIDDLE LEFT FRONT VERTICAL - W4L18897  
(x1) 15/16"x2 3/8"x27 15/16" (24x60x709)



MV4 - MIDDLE RIGHT FRONT VERTICAL - W4L18899  
(x1) 15/16"x2 3/8"x27 15/16" (24x60x709)

- ALIGN PILOT HOLES.

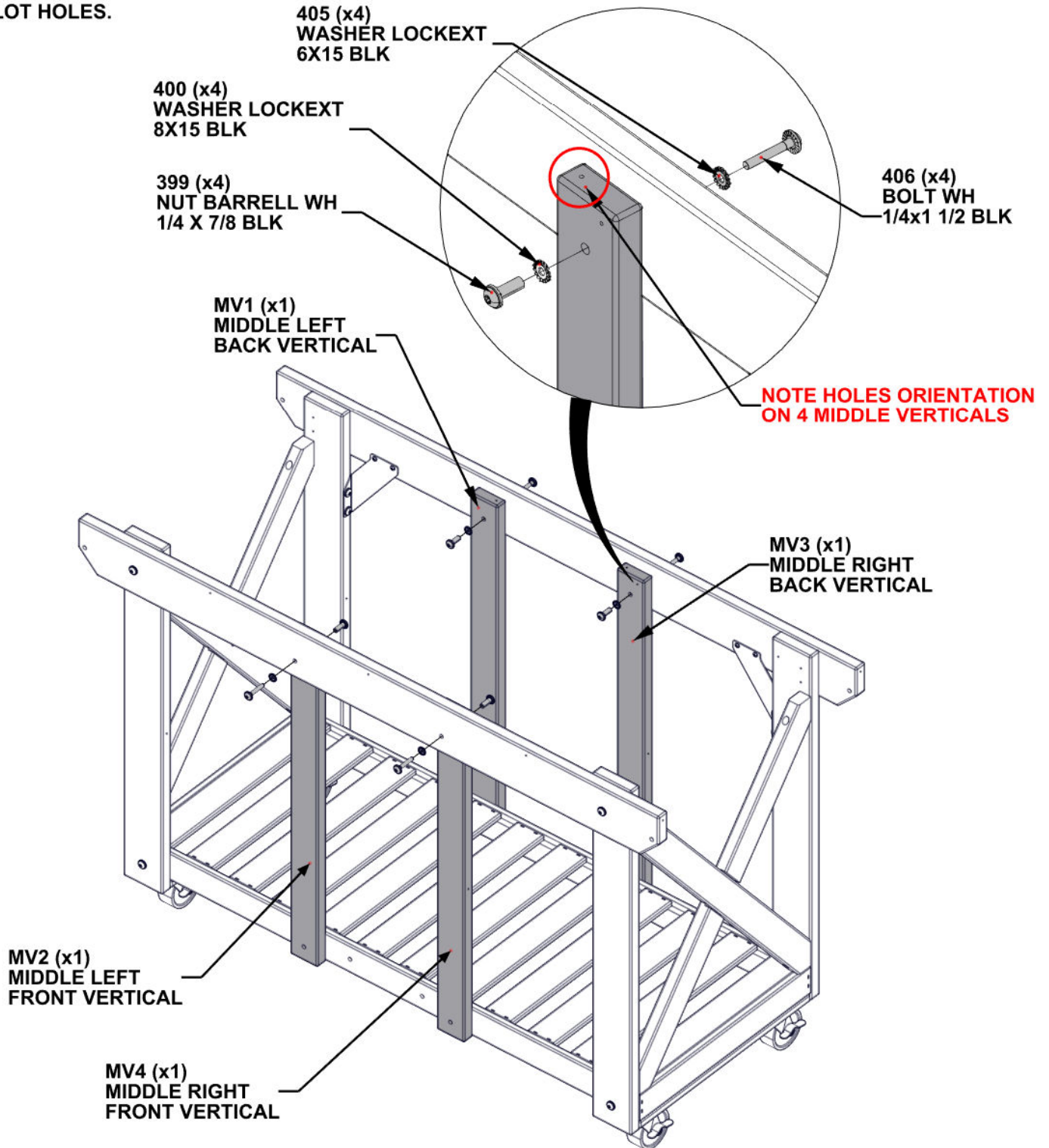

# STEP 7B - MIDDLE VERTICAL ASSEMBLY

Qty	Part No	Description
4	H100399	NUT BARRELL WH 1/4 X 7/8 BLK
4	H100400	WASHER LOCKEXT 8X15 BLK
4	H100405	WASHER LOCKEXT 6X15 BLK
4	H100406	BOLT WH 1/4x1 1/2 BLK

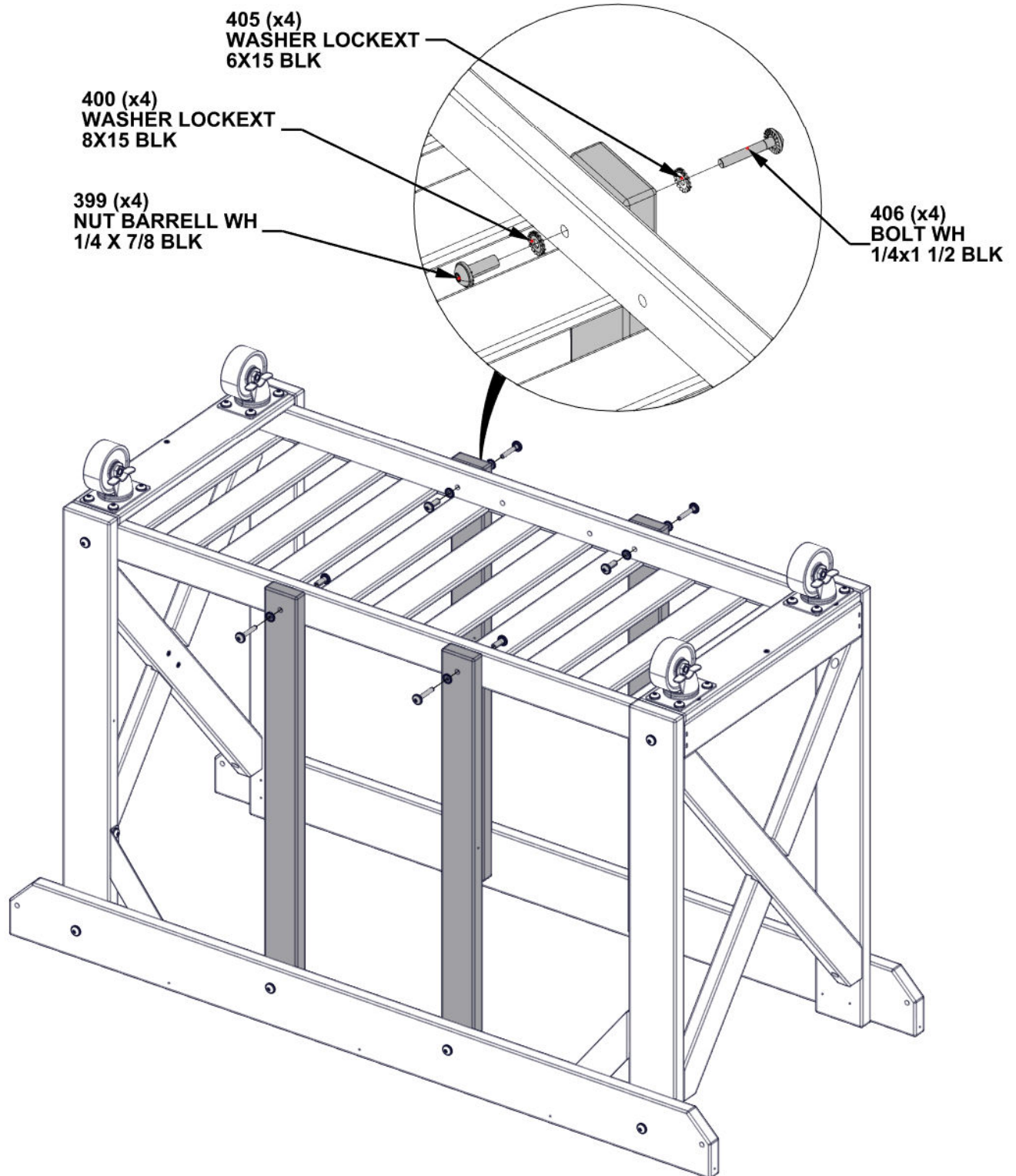

# STEP 8 - SUPPORT BOARD ASSEMBLY

Qty	Part No	Description
8	H100382	SCREW PFH 8x1-3/4 BLK



SB1 - SUPPORT BOARD - W4L18900  
(x4) 5/8"x1 5/16"x19 15/16" (16x34x506)

- ALIGN PILOT HOLES.

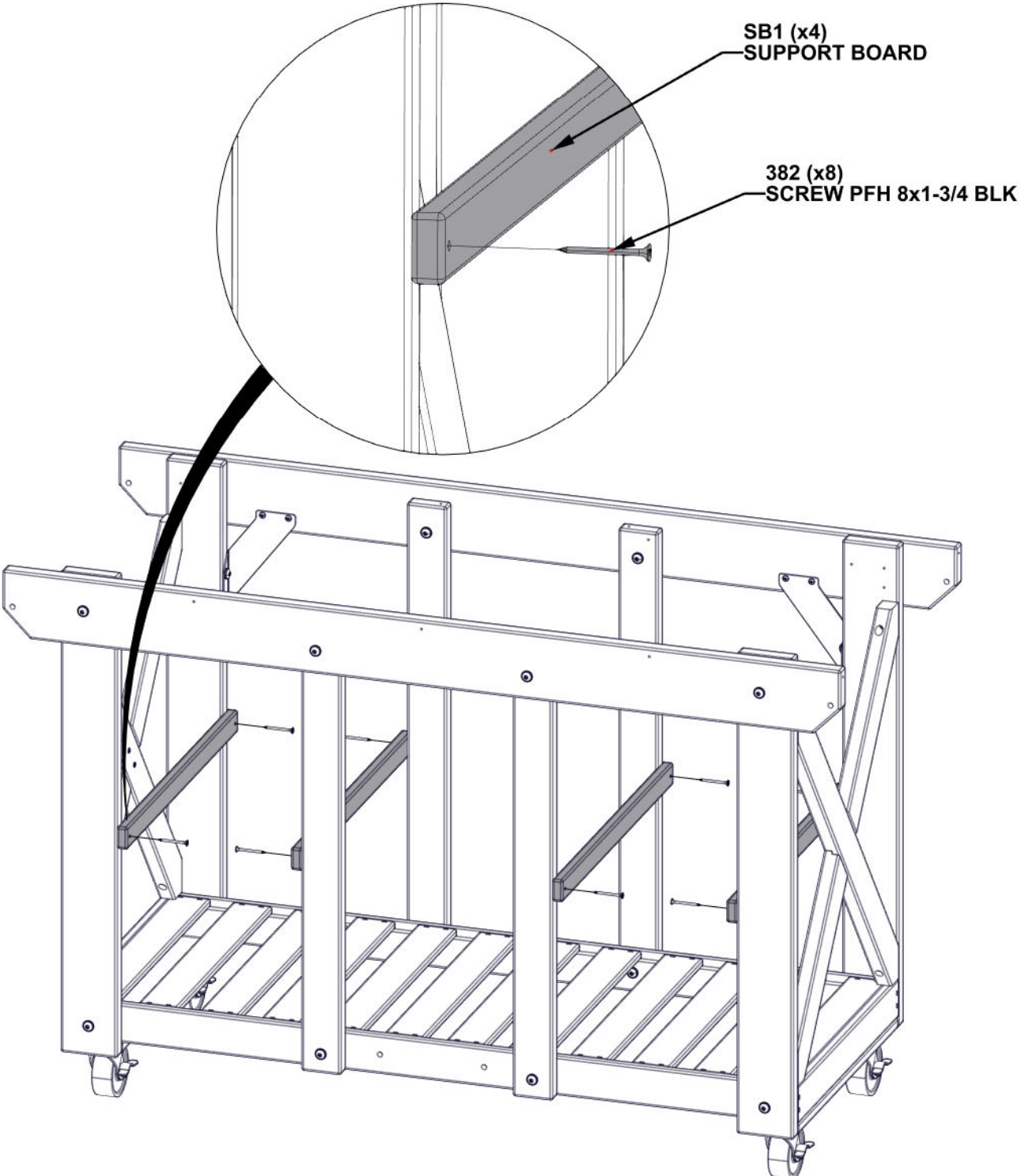

# STEP 9 - TABLE SHORT RAIL ASSEMBLY

Qty	Part No	Description
16	H100392	SCREW PWH 8X3/4 BLK



TA1 - TABLE SHORT RAIL -W2A04018  
(x2) 15/16"x4"x19 7/8" (24x102x505)

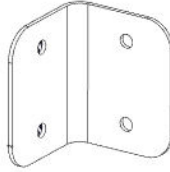

METAL BRACKET - A4M02540  
(x4)

- ALIGN PILOT HOLES.

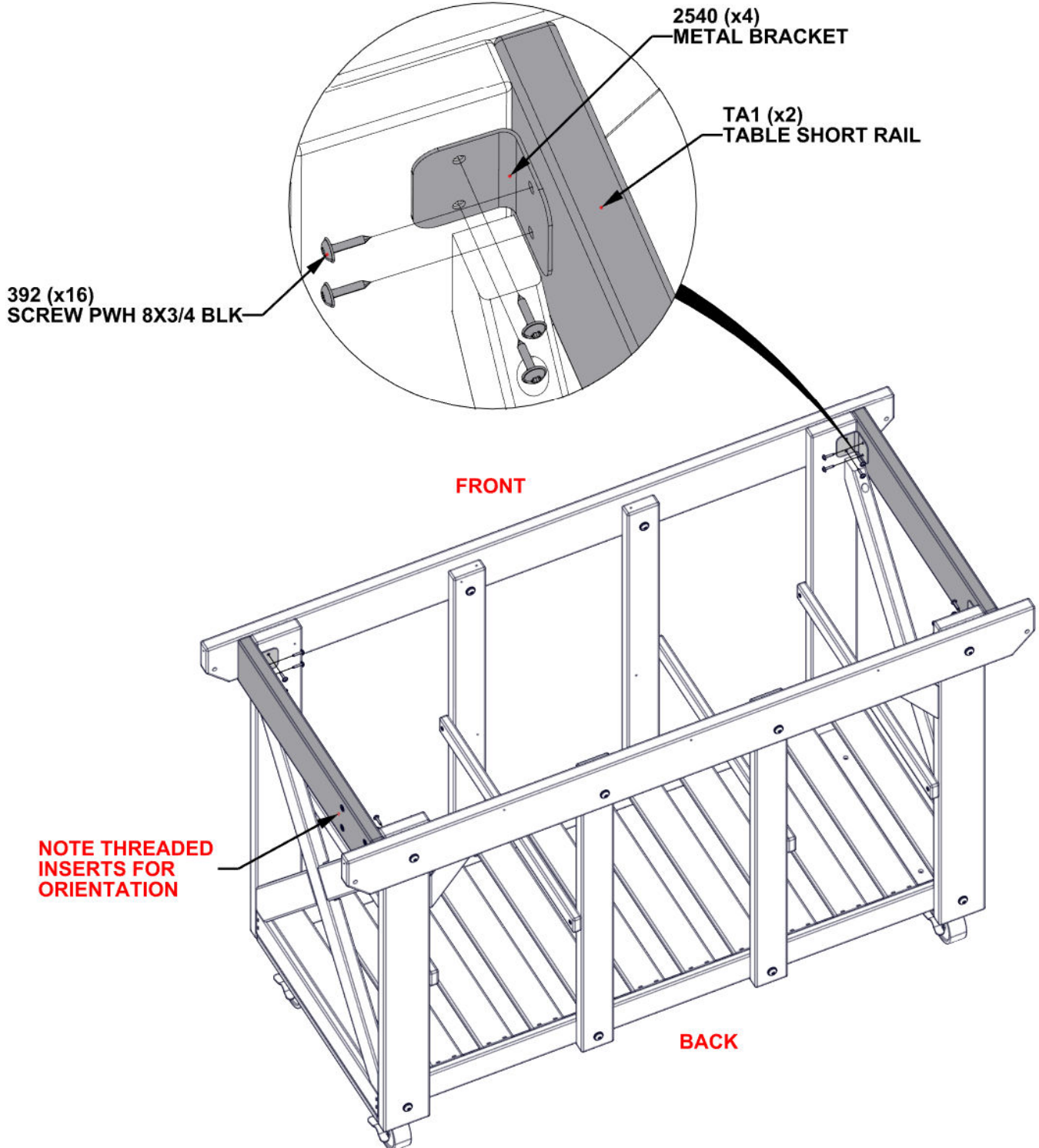

# STEP 10 - BOTTOM SLAT ASSEMBLY

Qty	Part No	Description
2	H100399	NUT BARRELL WH 1/4 X 7/8 BLK
2	H100400	WASHER LOCKEXT 8X15 BLK
2	H100405	WASHER LOCKEXT 6X15 BLK
2	H100406	BOLT WH 1/4x1 1/2 BLK



BS1 - BOTTOM SLAT - W4L18901  
(x1) 15/16"x2 3/8"x10 3/8" (24x60x263)

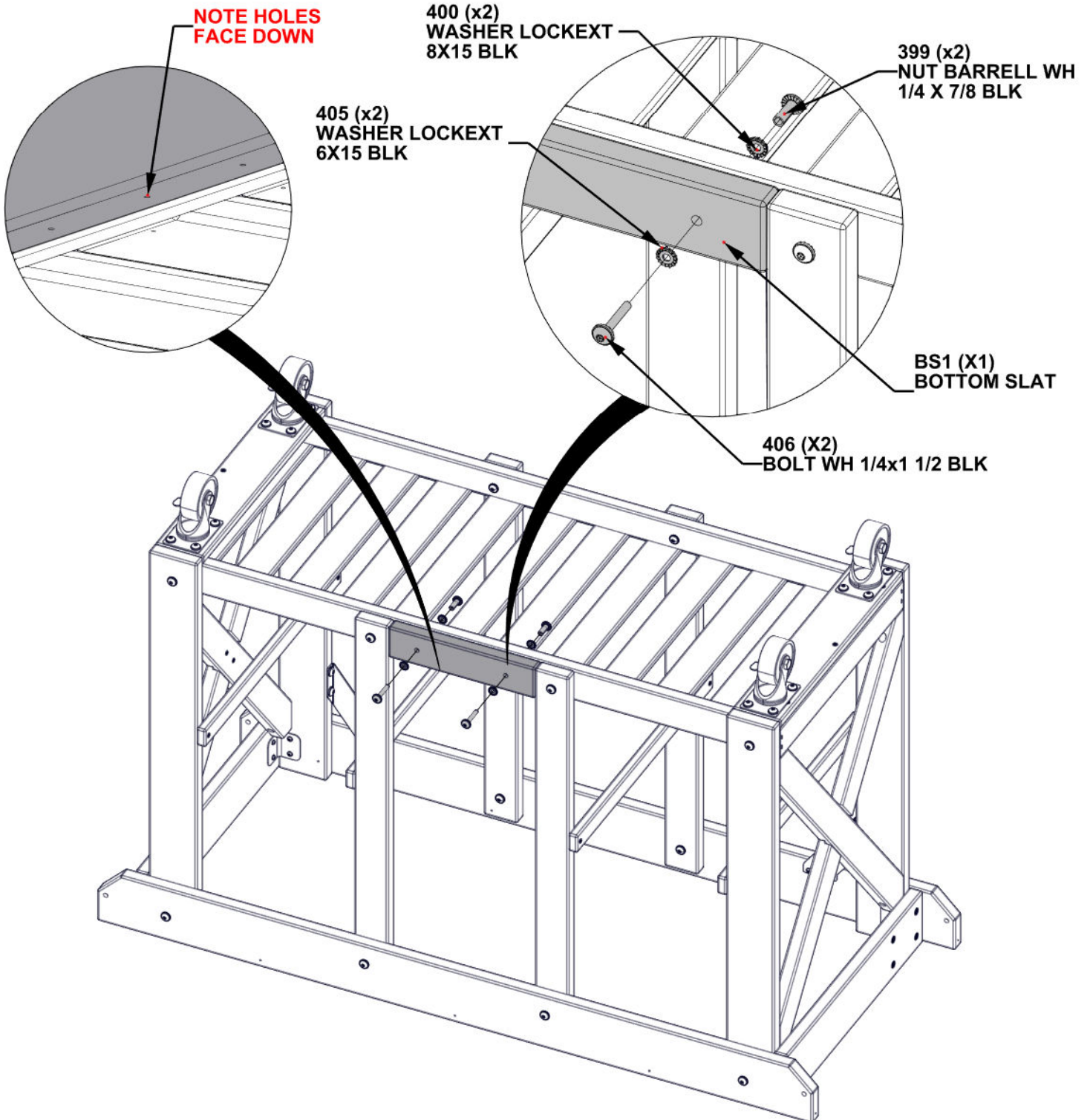

# STEP 11A - DRAWER HANDLE ASSEMBLY

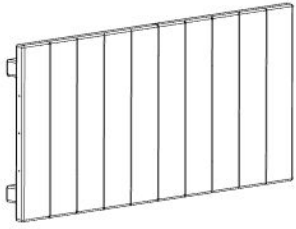

DA1 - DRAWER ASSEMBLY - W2A04017  
(x1) 1 9/16"x10 3/16"x22 1/16" (40x259x560)

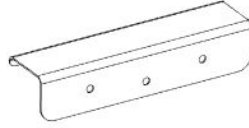

HANDLE - A4M02550  
(x1)

Qty	Part No	Description
3	H100408	SCREW PWH 8x1/2 BLK

- ALIGN PILOT HOLES.

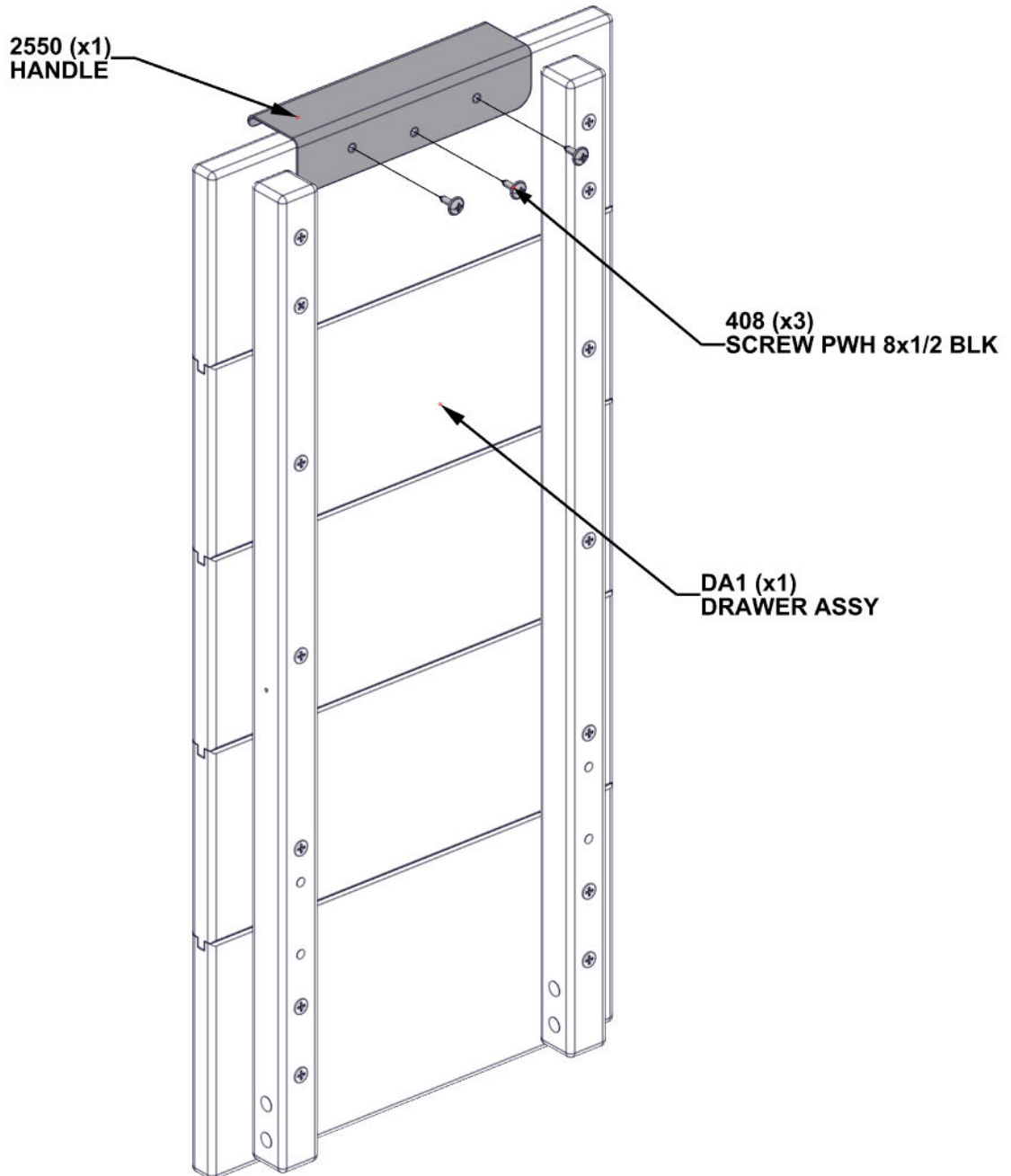

# STEP 11B - DRAWER SIDE BOARD ASSEMBLY



**DB1 - DRAWER SIDE BOARD - W4L20011**  
(x1) 5/8"x1 15/16"x16 1/2" (16x50x420)



**DB3 - DRAWER SIDE BOARD- W4L20013**  
(x1) 5/8"x1 15/16"x16 1/2" (16x50x420)

Qty	Part No	Description
4	H100397	BOLT WH 1/4x1-1/4 BLK
4	H100399	NUT BARRELL WH 1/4 X 7/8 BLK
4	H100400	WASHER LOCKEXT 8X15 BLK
4	H100405	WASHER LOCKEXT 6X15 BLK

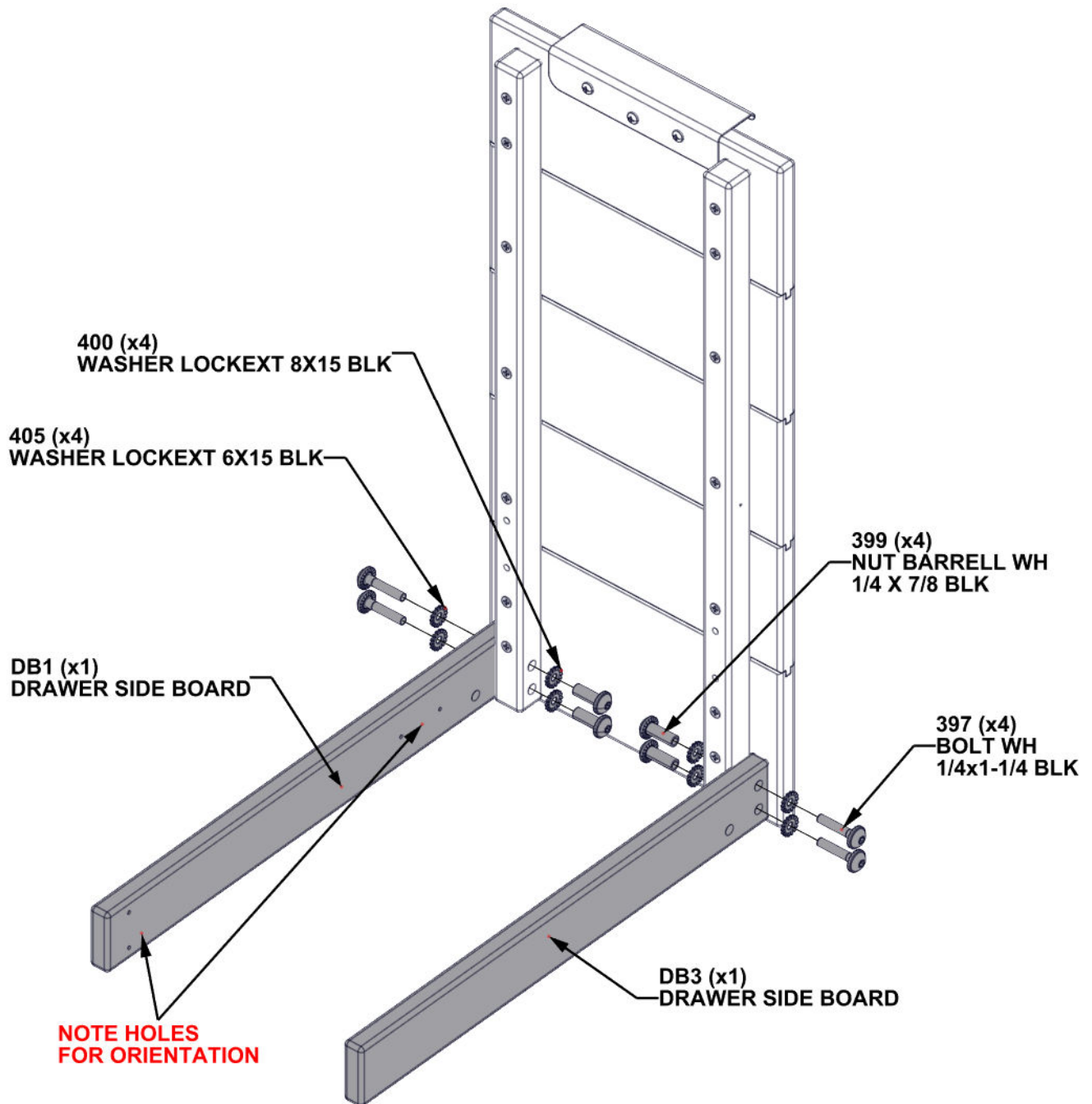

# STEP 11C - DRAWER BACK BOARD ASSEMBLY

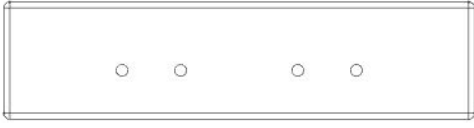

DB2 - DRAWER BACK BOARD - W4L20012  
(x1) 5/8"x2 3/8"x9 1/2" (16x60x241)

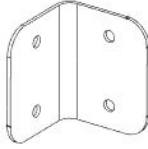

METAL BRACKET - A4M02540  
(x2)

Qty	Part No	Description
8	H100408	SCREW PWH 8x1/2 BLK

- ALIGN PILOT HOLES.

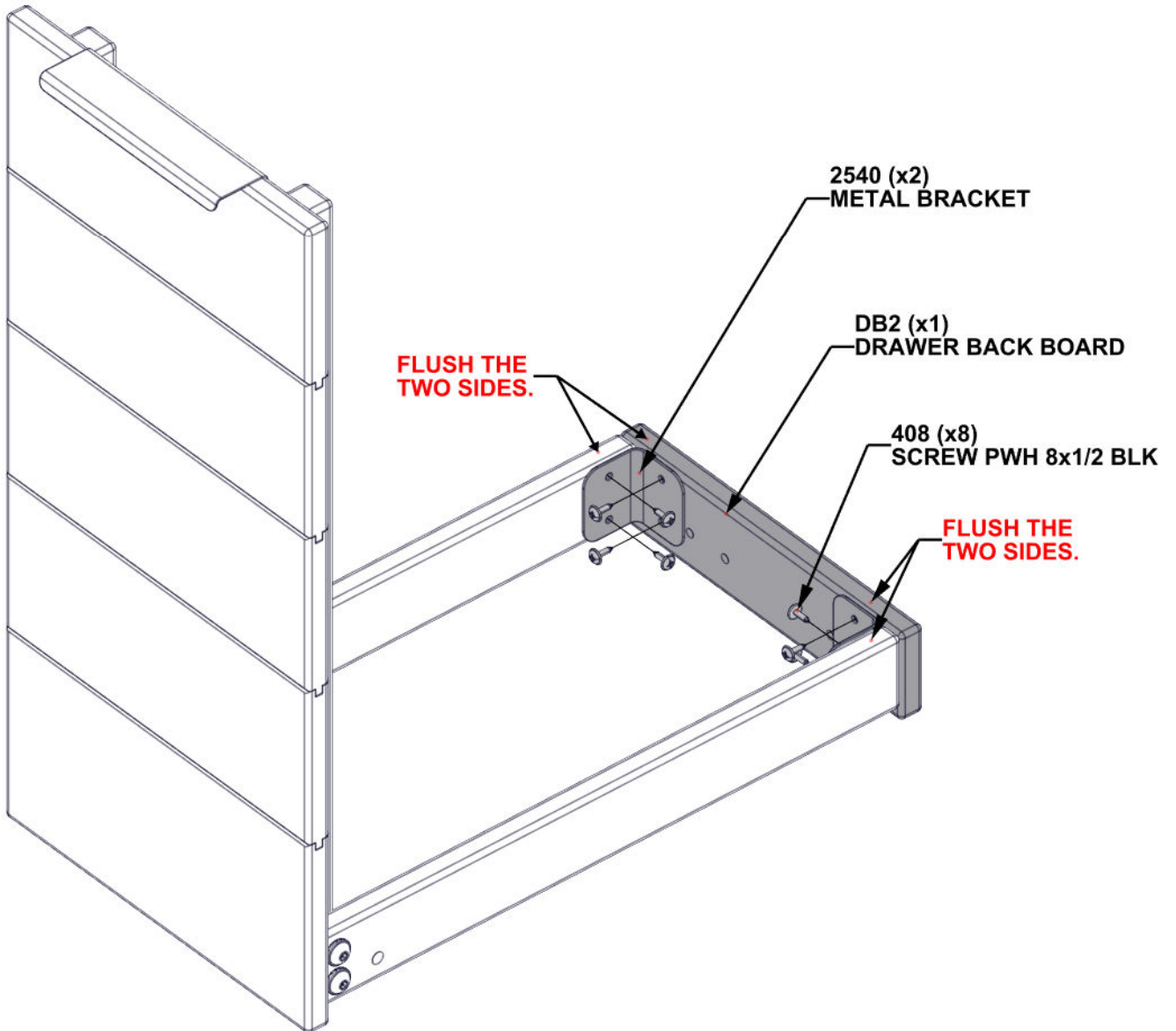

# STEP 11D - TRASH SUPPORT ASSEMBLY



TRASH SUPPORT - A4M02553  
(x4)

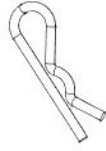

COTTER PIN - H101161  
(x4)



TRASH SUPPORT - A4M02554  
(x1)

Qty	Part No	Description
2	H100397	BOLT WH 1/4x1-1/4 BLK
2	H100405	WASHER LOCK EXT 6X15 BLK

- ALIGN 2554 TRASH SUPPORT WITH PILOT HOLES ON DRAWER SIDE BOARDS, THEN TIGHTEN BOLT AND WASHER.
- INSERT 2553 TRASH SUPPORT INTO 2554 TRASH SUPPORT THROUGH PILOT HOLES ON DRAWER BACK BOARD.
- USE COTTER PINS TO SECURE 2553.

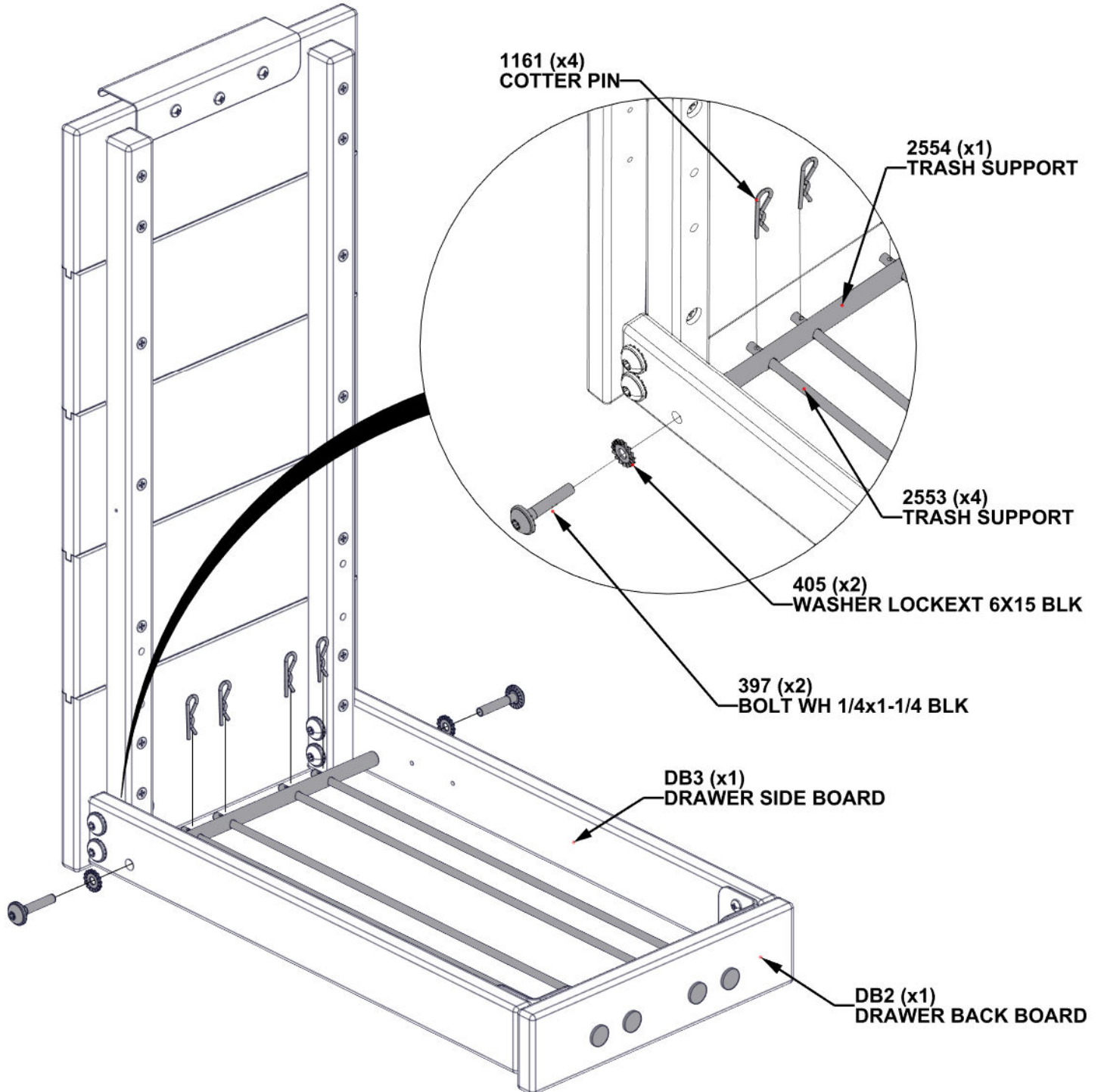

# STEP 11E - METAL ANGLE BRACE ASSEMBLY

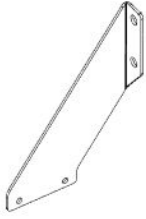

Qty	Part No	Description
4	H100408	SCREW PWH 8x1/2 BLK
4	H100460	LAG SCREW WH 1/4 X 1 BLK

METAL ANGLE BRACE LEFT - A4M02539  
(x1)

METAL ANGLE BRACE RIGHT - A4M02538  
(x1)

- ALIGN PILOT HOLES.

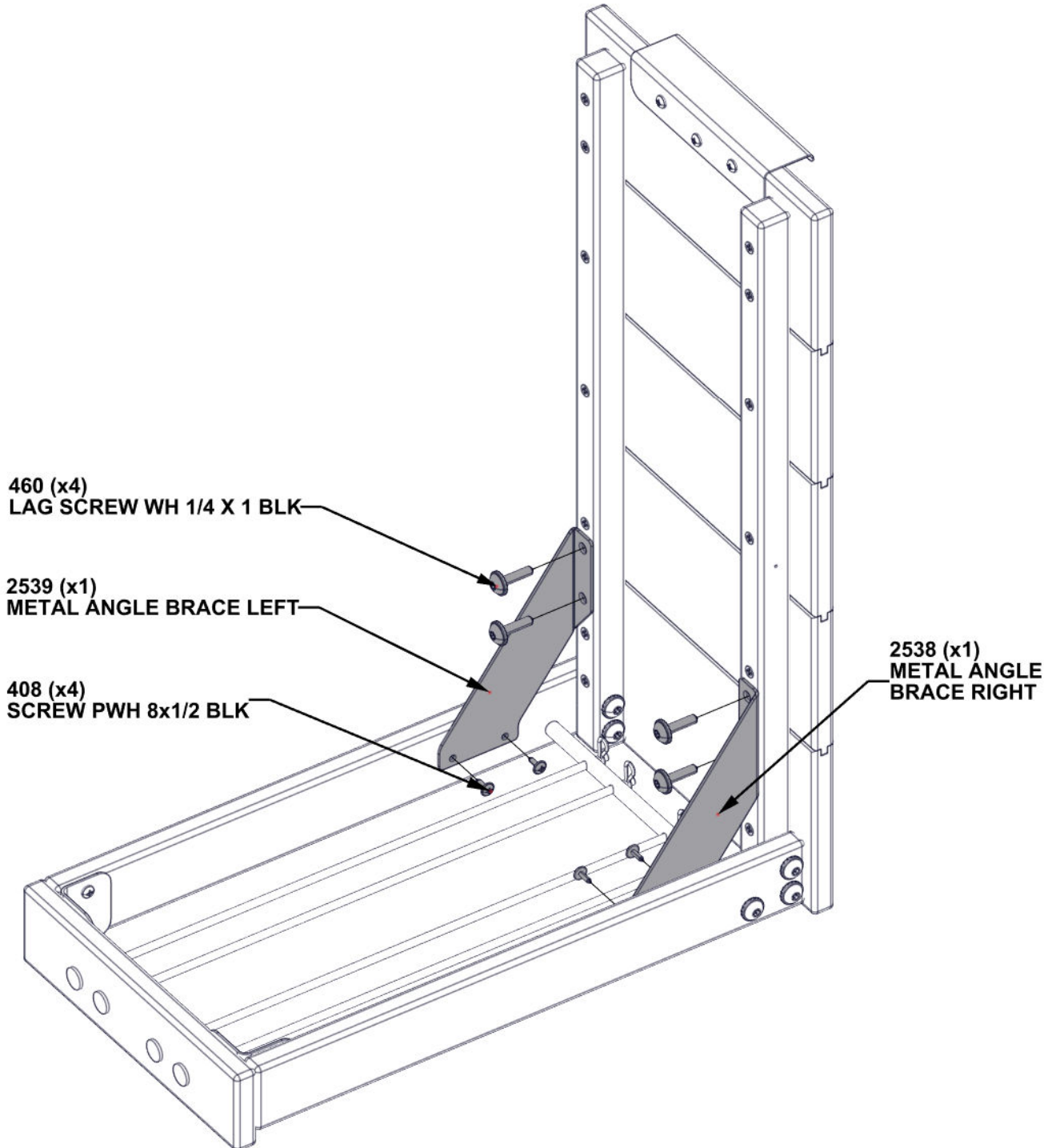

# STEP 12A - PIANO HINGE ASSEMBLY

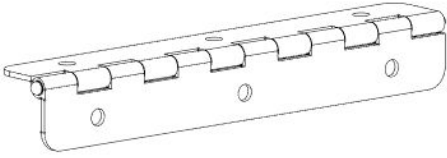

PIANO HINGE - A4M02549  
(x1)

Qty	Part No	Description
3	H101296	SCREW PFH-BLUNT TIP 6x1/2

- ALIGN PILOT HOLES.

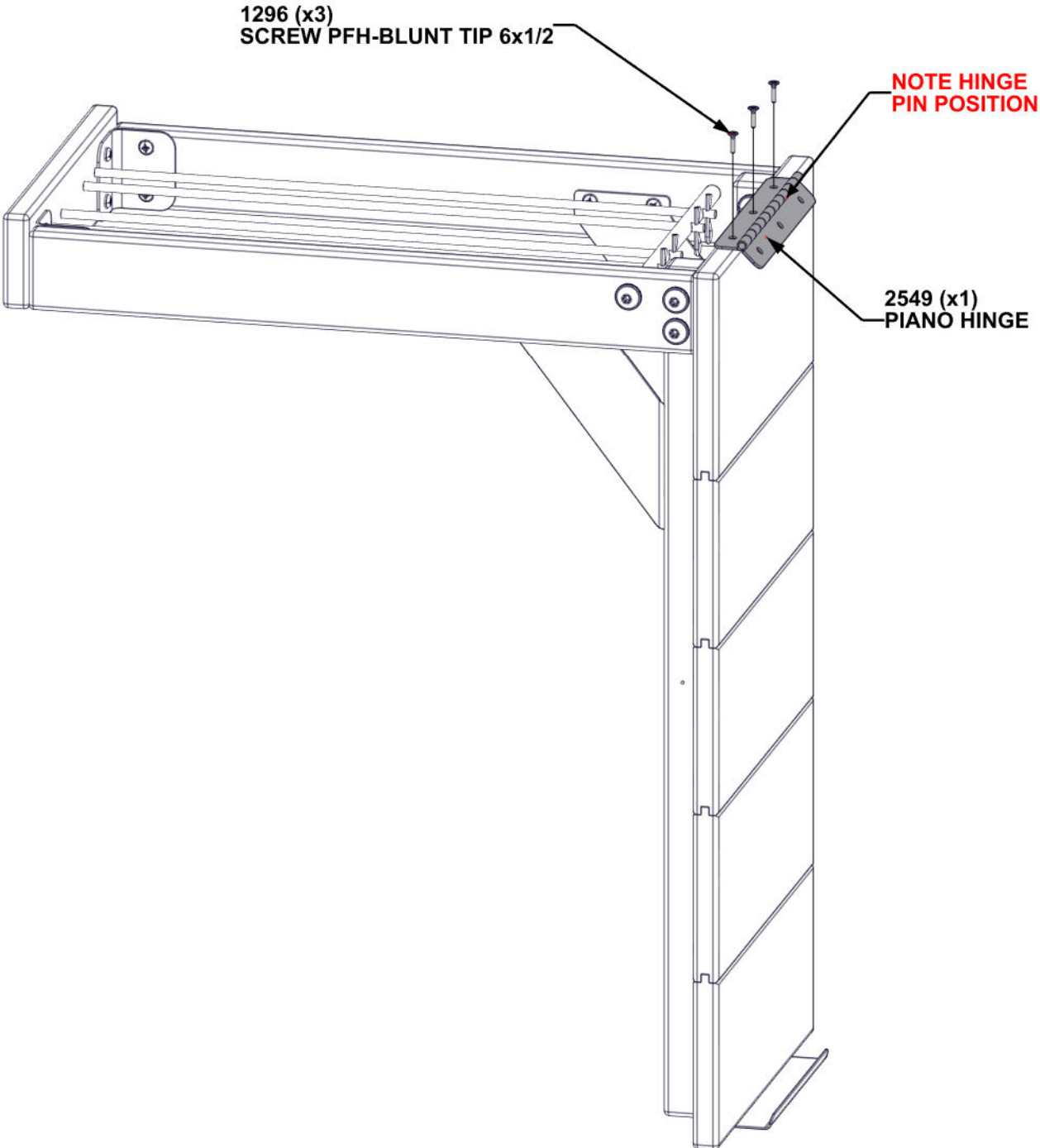

# STEP 12B - PIANO HINGE ASSEMBLY

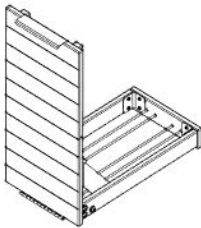

Qty	Part No	Description
3	H101296	SCREW PFH-BLUNT TIP 6x1/2

PIANO HINGE ASSEMBLY - STEP - 12A

- ALIGN PILOT HOLES.

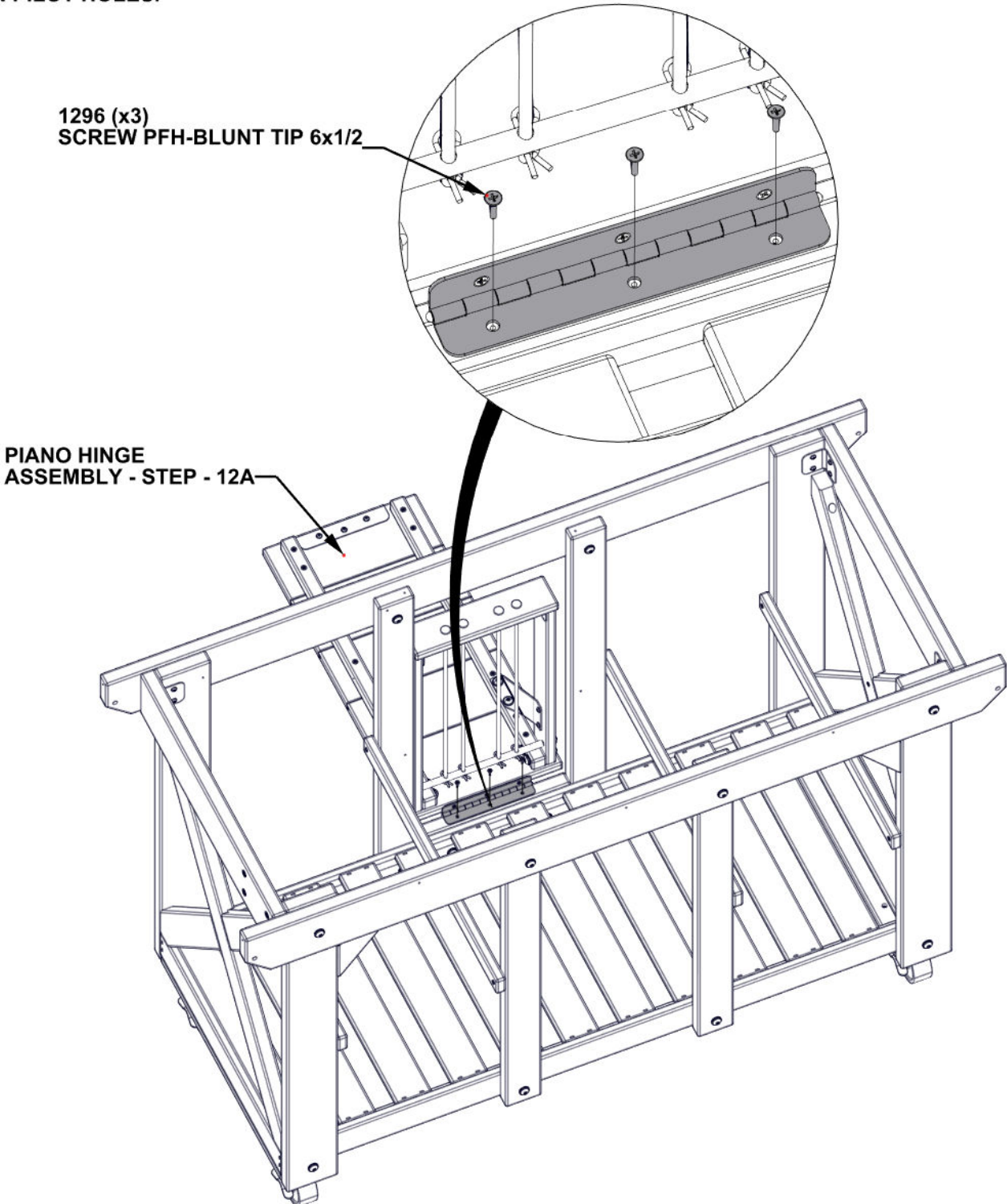

# STEP 13 - TRASH CAN DOOR CHAIN ASSEMBLY



TRASH CAN DOOR CHAIN - A4M04127  
(x2)

Qty	Part No	Description
2	H100392	SCREW PWH 8X3/4 BLK

- ATTACH TRASH CAN DOOR CHAIN
- TIGHTEN ALL SCREWS

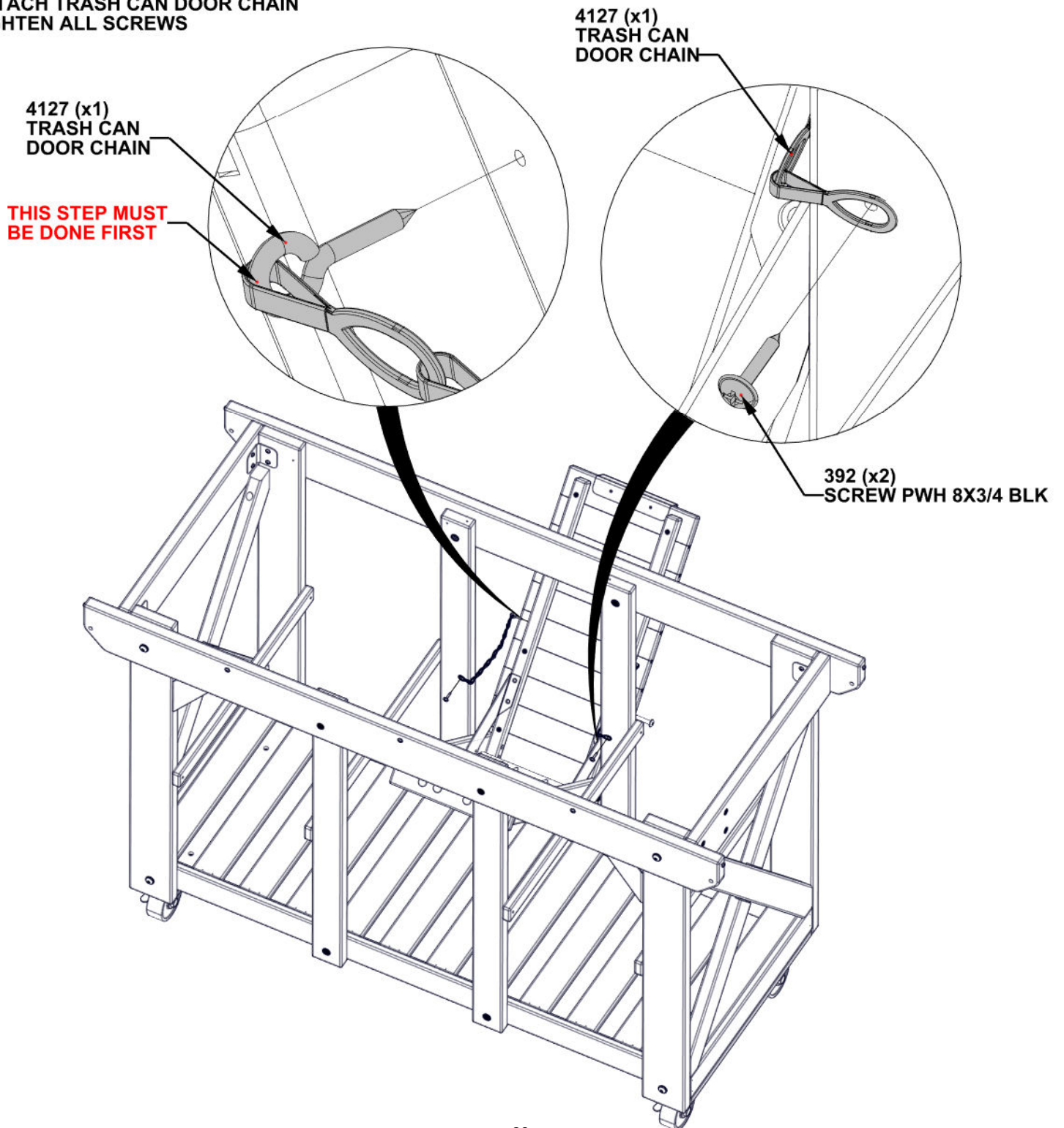

# STEP 14 - TOP MIDDLE SHORT CLEAT ASSEMBLY

Qty	Part No	Description
4	H100382	SCREW PFH 8x1-3/4 BLK



BS3-TOP MIDDLE SHORT CLEAT - W4L18903  
(x2) 15/16"x15/16"x19 15/16" (24x24x506)

- ALIGN PILOT HOLES.

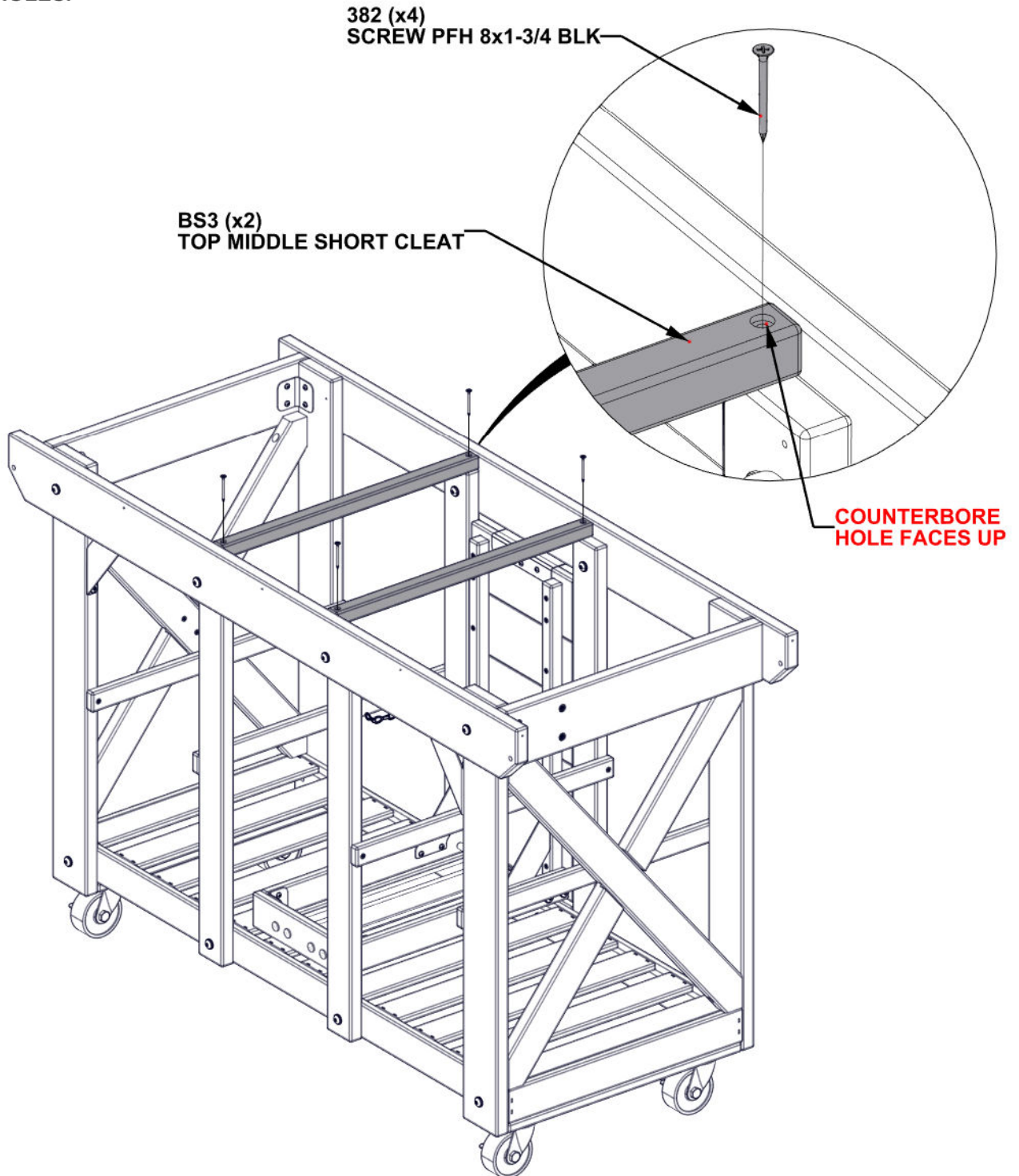

# STEP 15 - CUP HANGER BOARD ASSEMBLY

Qty	Part No	Description
6	H101069	SCREW PWH 8X7/8 BLK



**BS4-CUP HANGER BOARD - W4L18904**  
(x2) 15/16"x15/16"x13 7/8" (24x24x352)

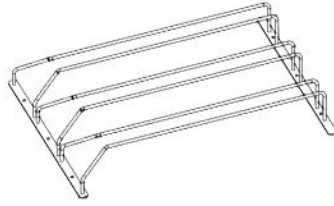

**HANGER TUBE - A4M02541**  
(x1)

- ALIGN PILOT HOLES.

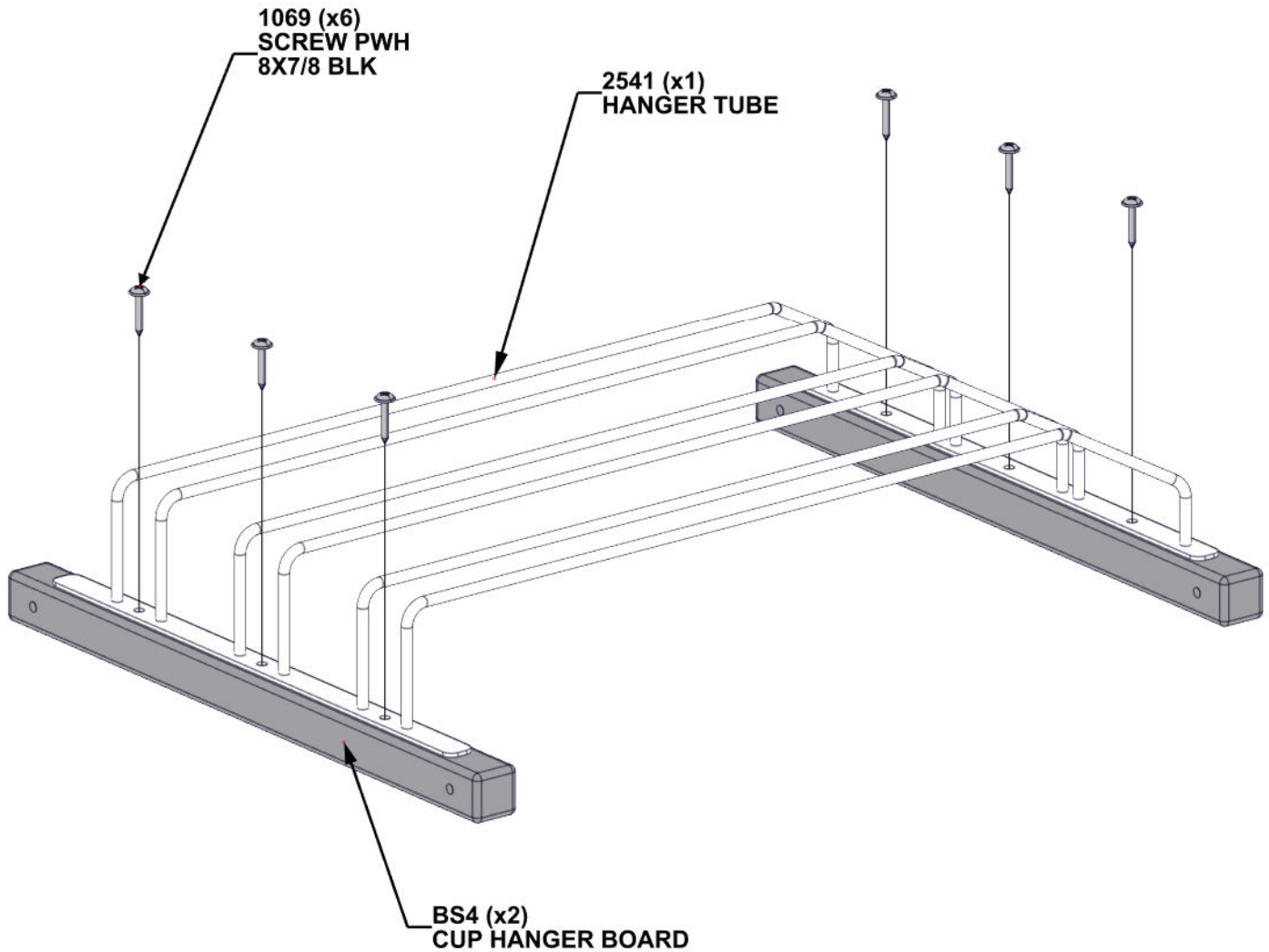

# STEP 16 - CUP HANGER ASSEMBLY

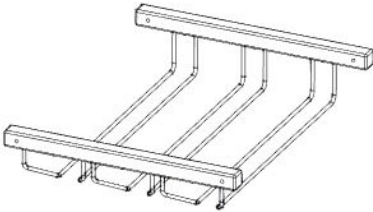

Qty	Part No	Description
4	H100835	SCREW PWH 8X2 BLK

CUP HANGER BOARD ASSEMBLY - STEP - 15

- ALIGN PILOT HOLES.

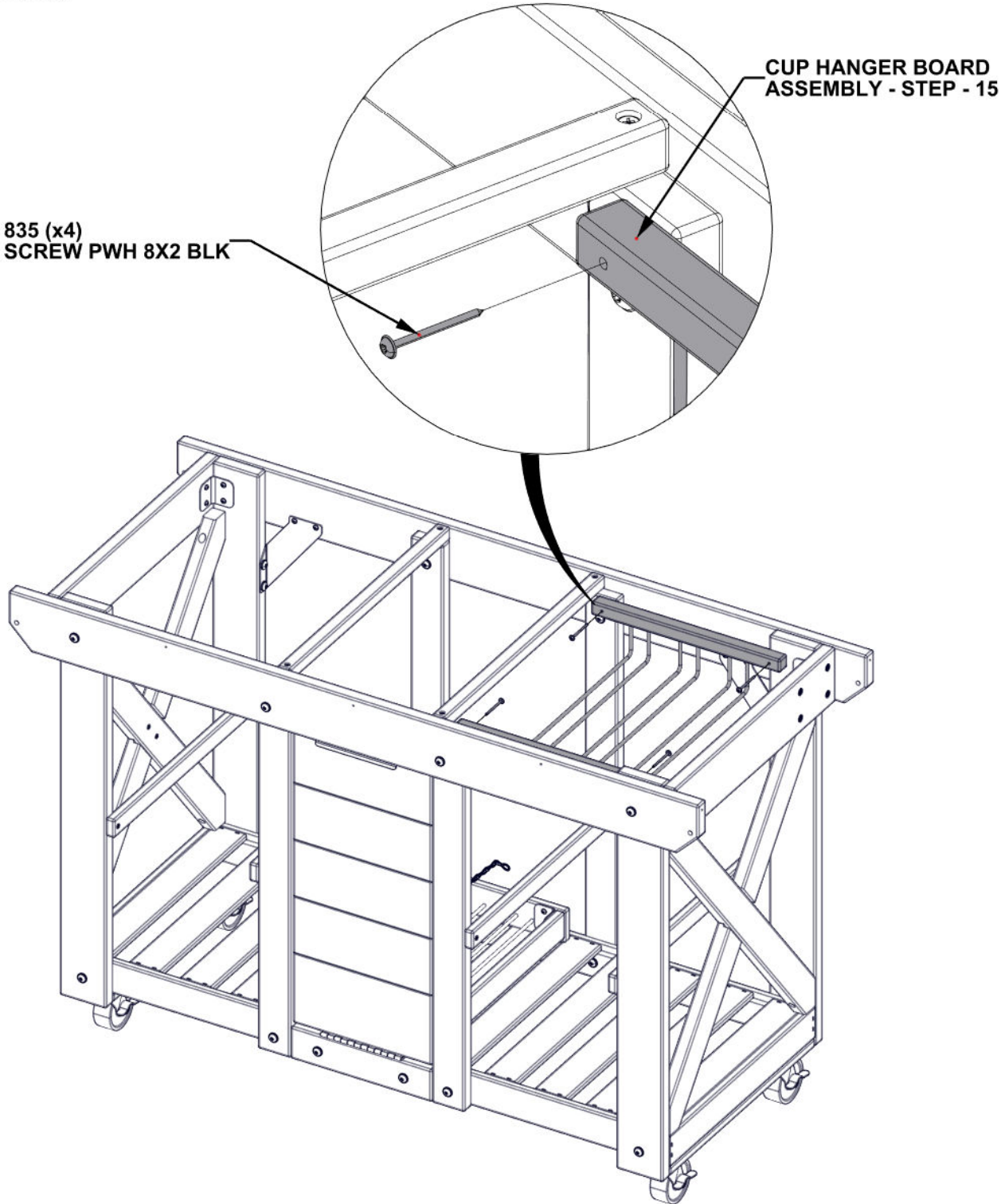

# STEP 17 - BACK SHELF UPRIGHT ASSEMBLY

Qty	Part No	Description
8	H100405	WASHER LOCK EXT 6X15 BLK
8	H100406	BOLT WH 1/4x1 1/2 BLK



**BS5 - BACK LEFT SHELF UPRIGHT - W4L18905**  
(x1) 15/16"x5 1/4"x27 11/16" (24x134x703)



**BS6 - BACK RIGHT SHELF UPRIGHT - W4L18906**  
(x1) 15/16"x5 1/4"x27 11/16" (24x134x703)

- ALIGN PILOT HOLES.

**NOTE HOLES FOR ORIENTATION**

**406 (x8)  
BOLT WH  
1/4x1 1/2 BLK**

**405 (x8)  
WASHER LOCKEXT  
6X15 BLK**

**BS5 (x1)  
BACK LEFT  
SHELF UPRIGHT**

**BS6 (x1)  
BACK RIGHT  
SHELF UPRIGHT**

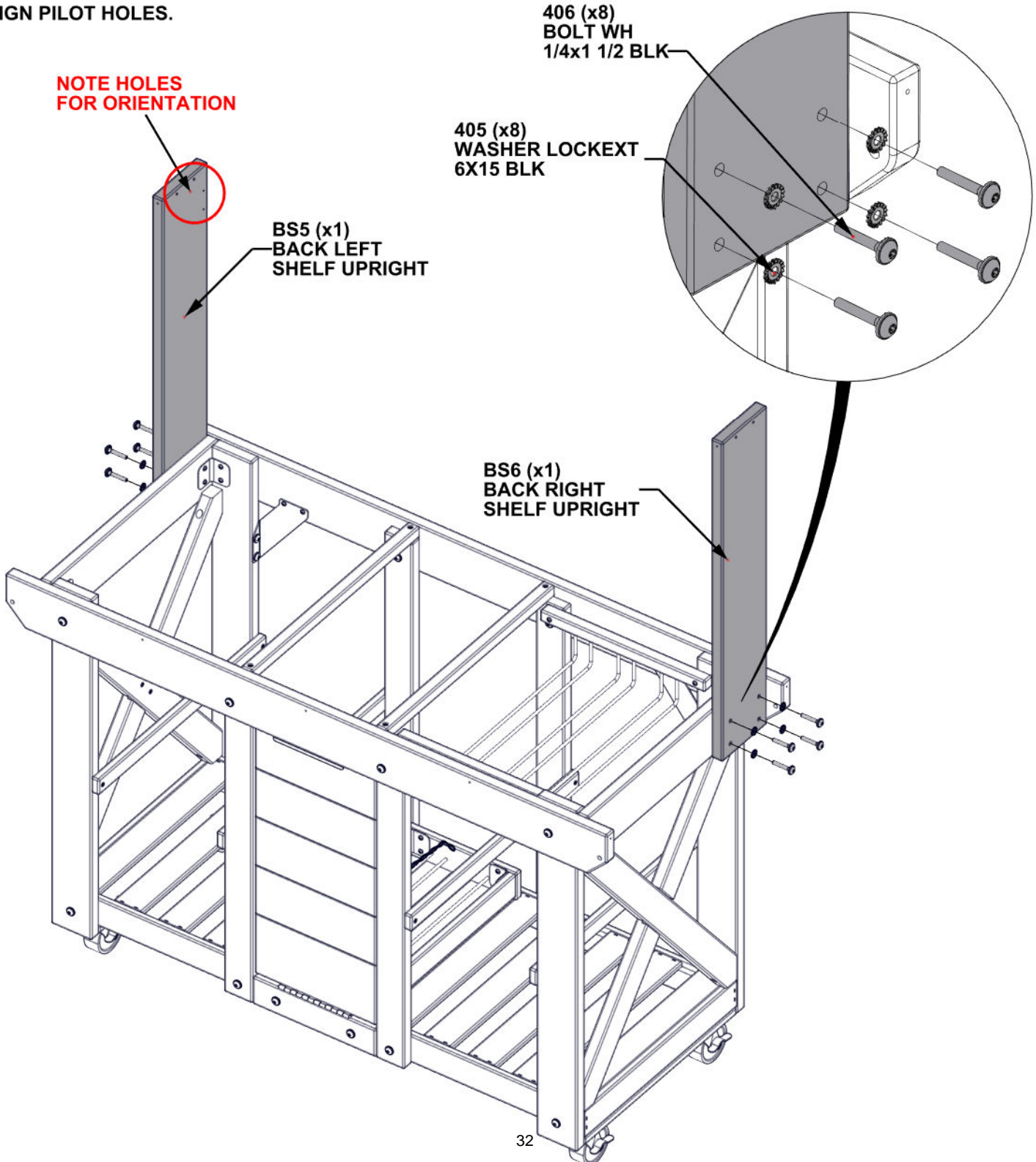

# STEP 18 - TOWEL BAR ASSEMBLY

Qty	Part No	Description
4	H100405	WASHER LOCK EXT 6X15 BLK
4	H100406	BOLT WH 1/4x1 1/2 BLK



TOWEL BAR - A4M02542  
(x2)

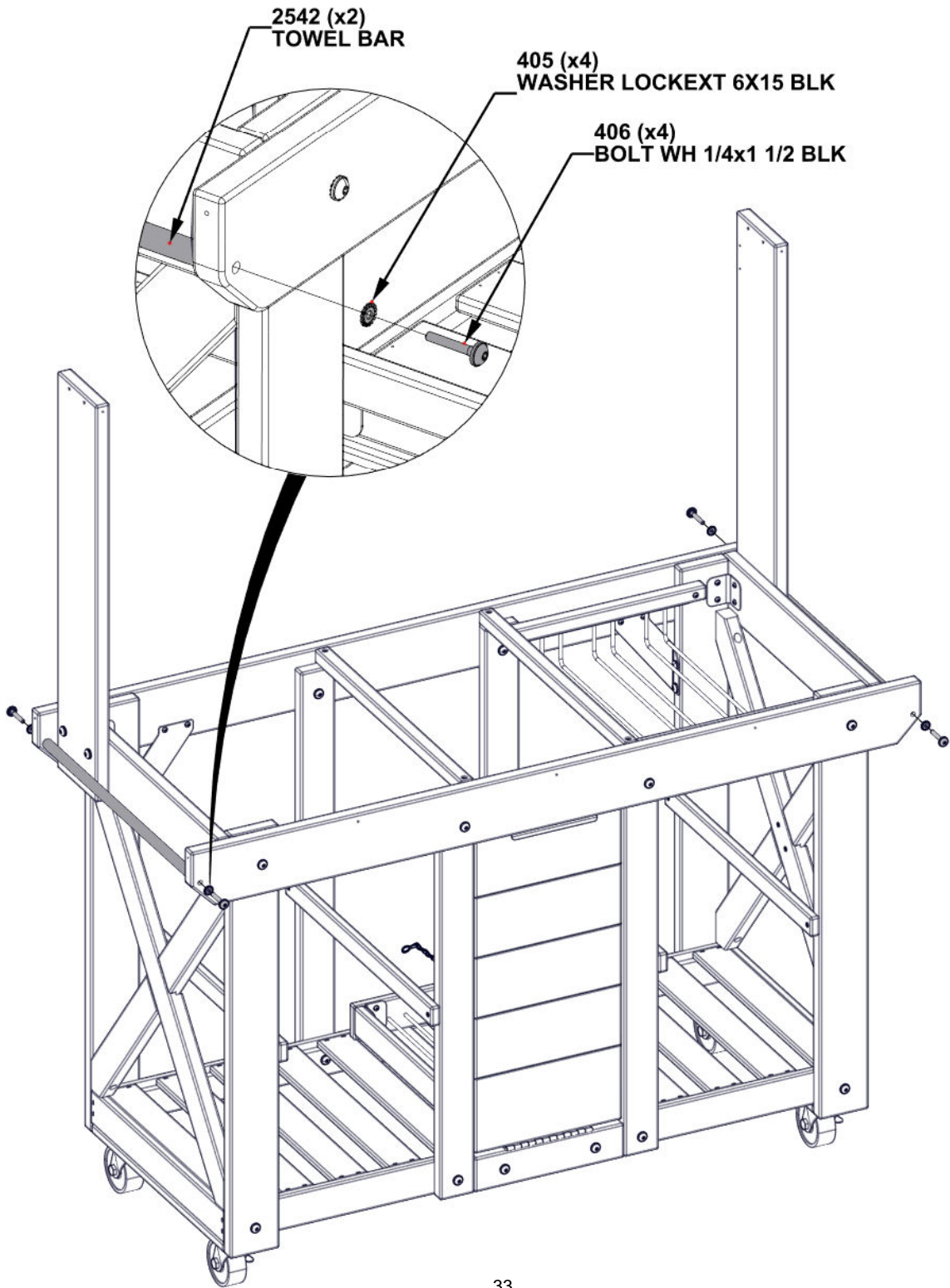

# STEP 19 - TABLE ASSEMBLY

Qty	Part No	Description
10	H100392	SCREW PWH 8X3/4 BLK

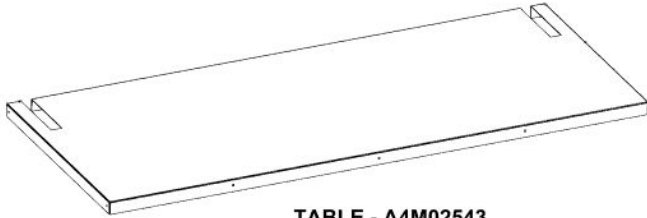
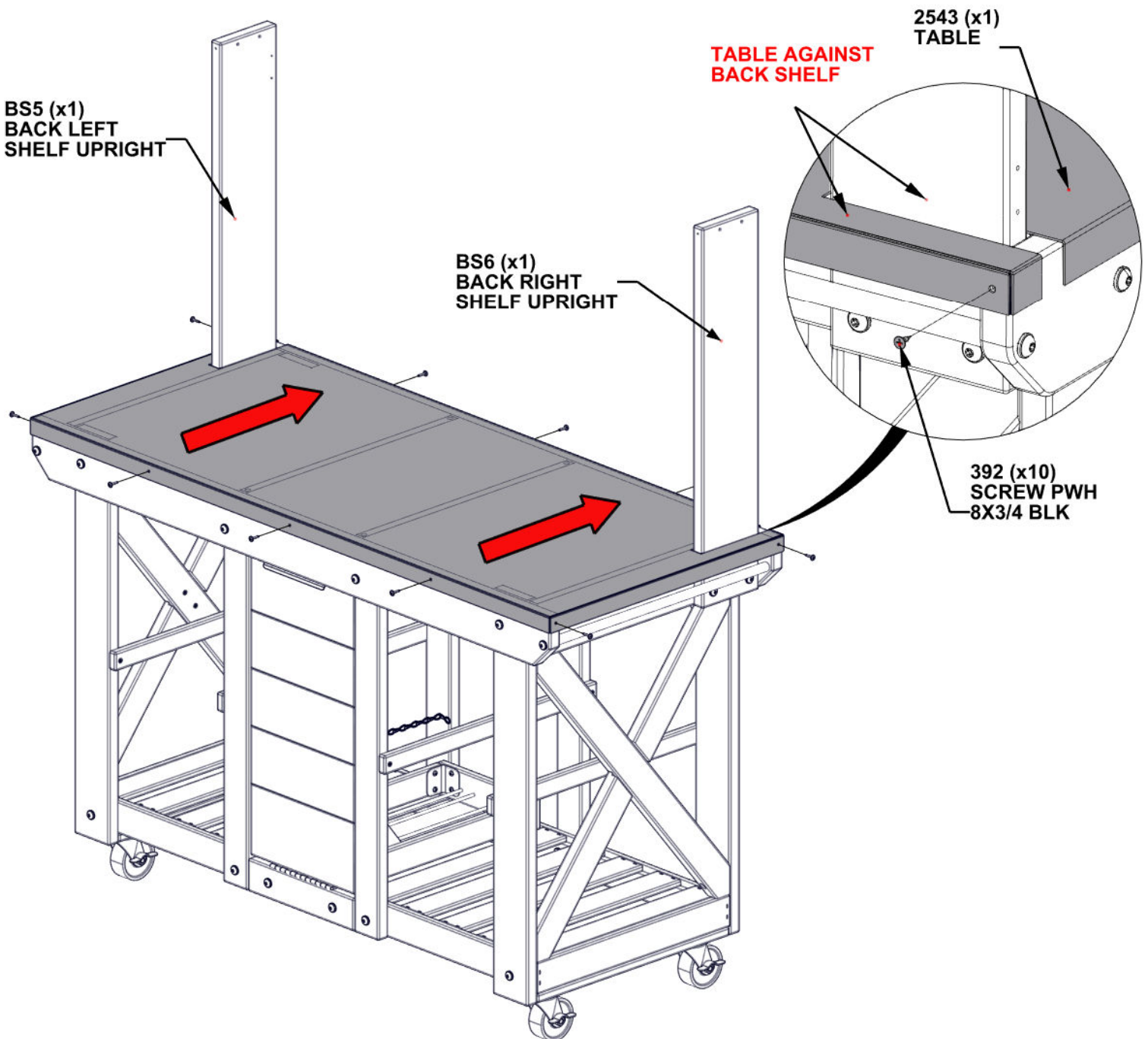

TABLE - A4M02543  
(x1)

- IT IS RECOMMENDED TO HAVE TWO PEOPLE SET TABLE IN PLACE.
- SLIDE IN PLACE UNTIL TABLE IS AGAINST BACK SHELF UPRIGHT (BS5 AND BS6).
- ALIGN HARDWARE WITH PILOT HOLES TO AVOID SPLITTING.
- **WHEN SETTING TABLE IN PLACE, MAKE SURE YOUR FINGERS ARE CLEAR AND NOT UNDERNEATH TABLE.**
- **IT IS RECOMMENDED TO WEAR GLOVES WHEN HANDLING THE TABLE.**



# STEP 20 - TOP SHELF BOARD ASSEMBLY

Qty	Part No	Description
4	H100382	SCREW PFH 8x1-3/4 BLK



TS3 TOP SHELF BOARD - W4L18909  
(x1) 15/16"x5 1/4"x48 3/16" (24x134x1173)

- ALIGN PILOT HOLES.

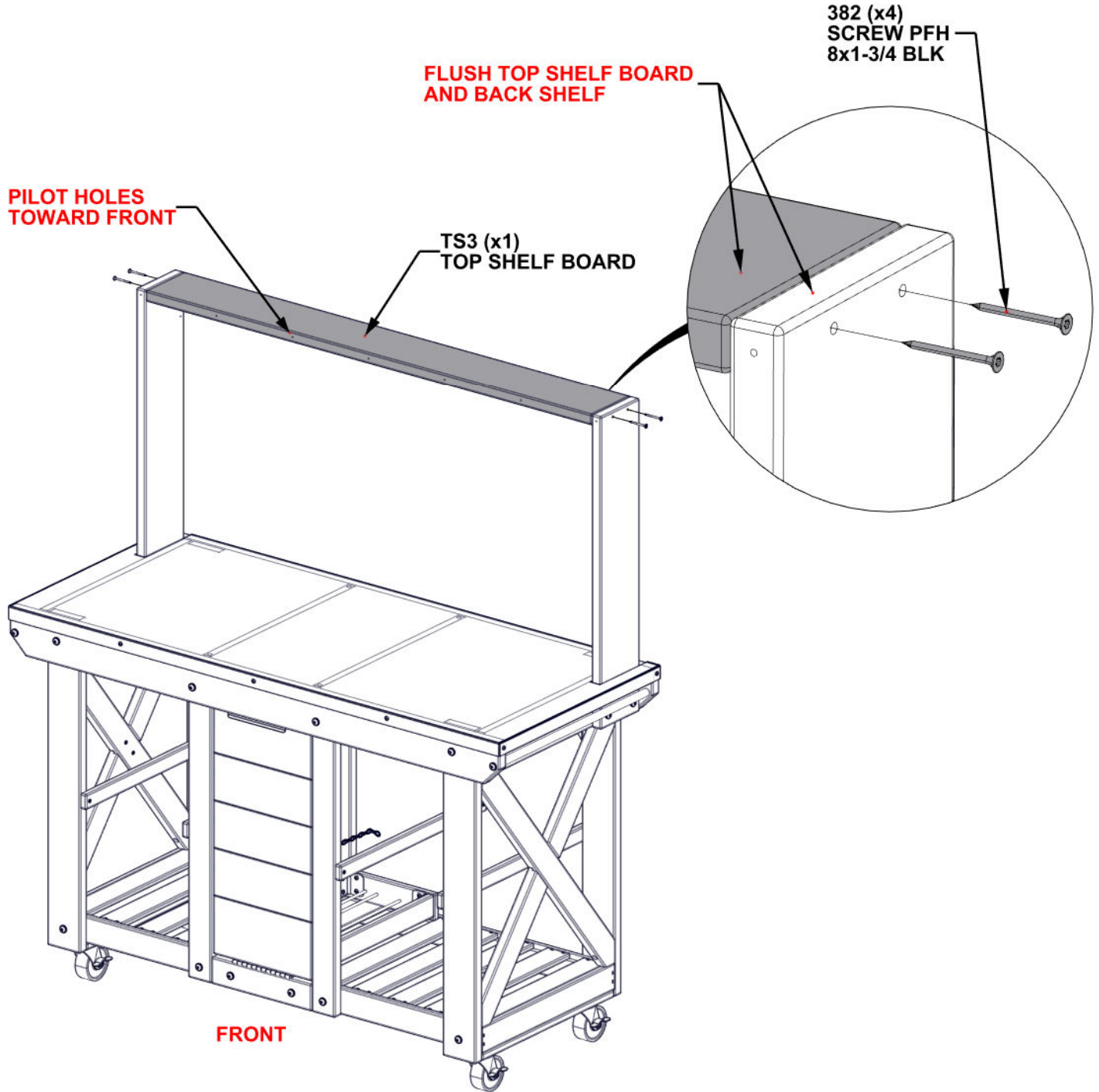

# STEP 21 - TOP SLAT ASSEMBLY

Qty	Part No	Description
24	H100382	SCREW PFH 8x1-3/4 BLK



TS1 - TOP SLAT\_1 - W4L18907  
(x5) 15/16"x2 3/8"x48 1/16" (24x60x1221)



TS2 - TOP SLAT\_2 - W4L18908  
(x1) 15/16"x2 3/8"x48 1/16" (24x60x1221)

- ALIGN PILOT HOLES.

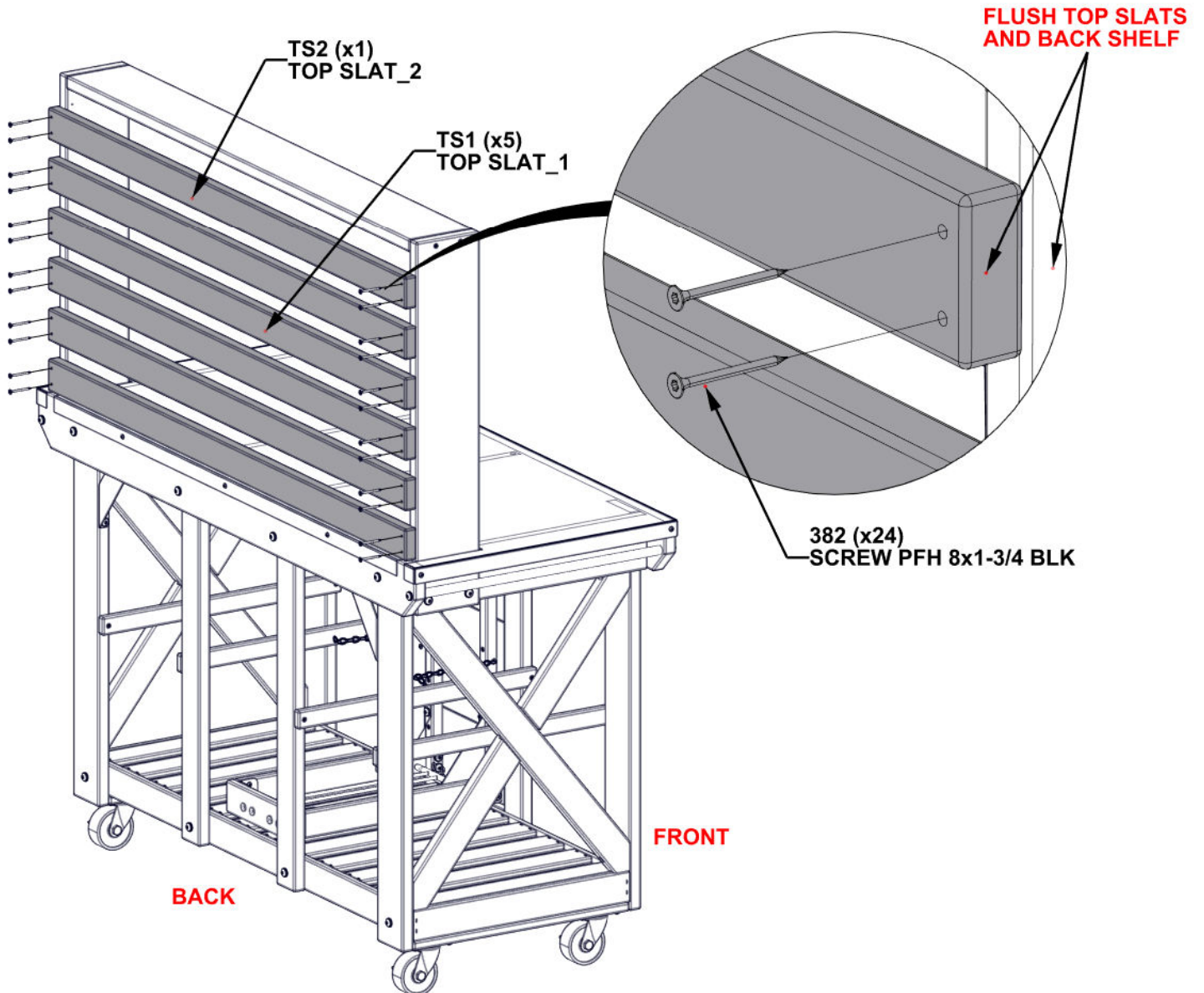
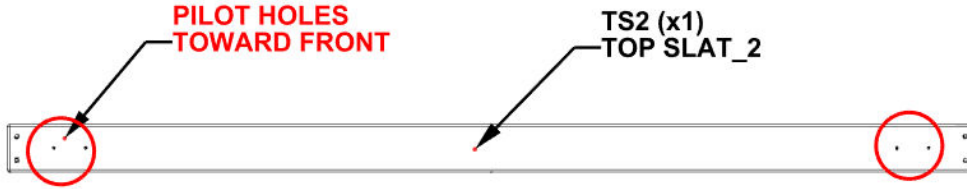

# STEP 22 - METAL ANGLE TOP BRACE ASSEMBLY

Qty	Part No	Description
8	H100392	SCREW PWH 8X3/4 BLK

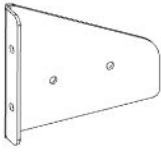

METAL ANGLE TOP BRACE LEFT - A4M02544  
(x1)

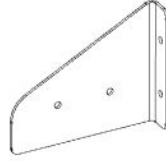

METAL ANGLE TOP BRACE RIGHT - A4M02545  
(x1)

- ALIGN PILOT HOLES.

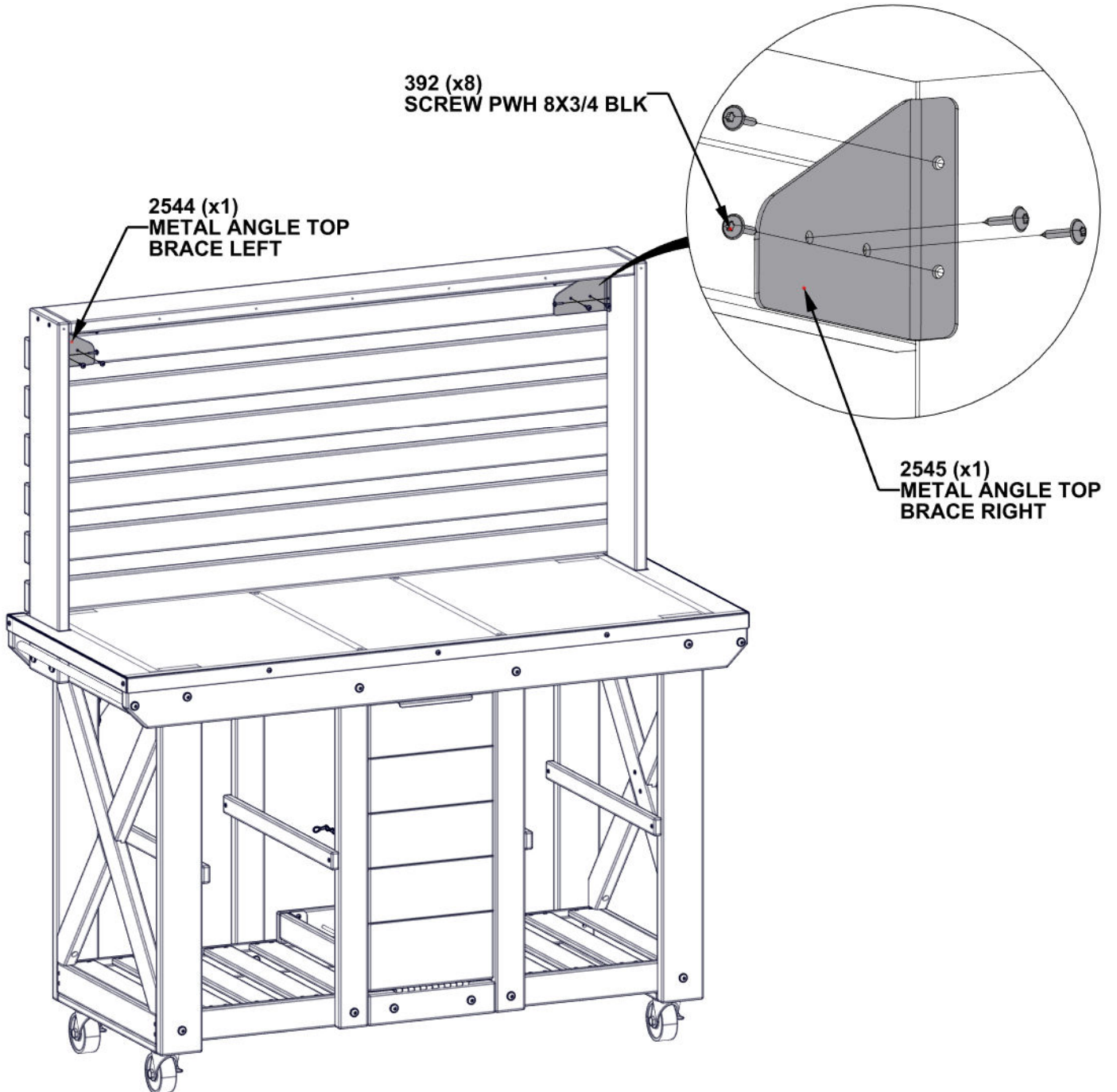

# STEP 23 - CHAMFERED TOP BOARD ASSEMBLY

Qty	Part No	Description
7	H100823	SCREW PWH 8X1 1/2 BLK



CB3 CHAMFERED TOP BOARD - W4L18911  
(x1) 15/16"x3 3/8"x 49 3/8" (24x86x1255)

- ALIGN PILOT HOLES.

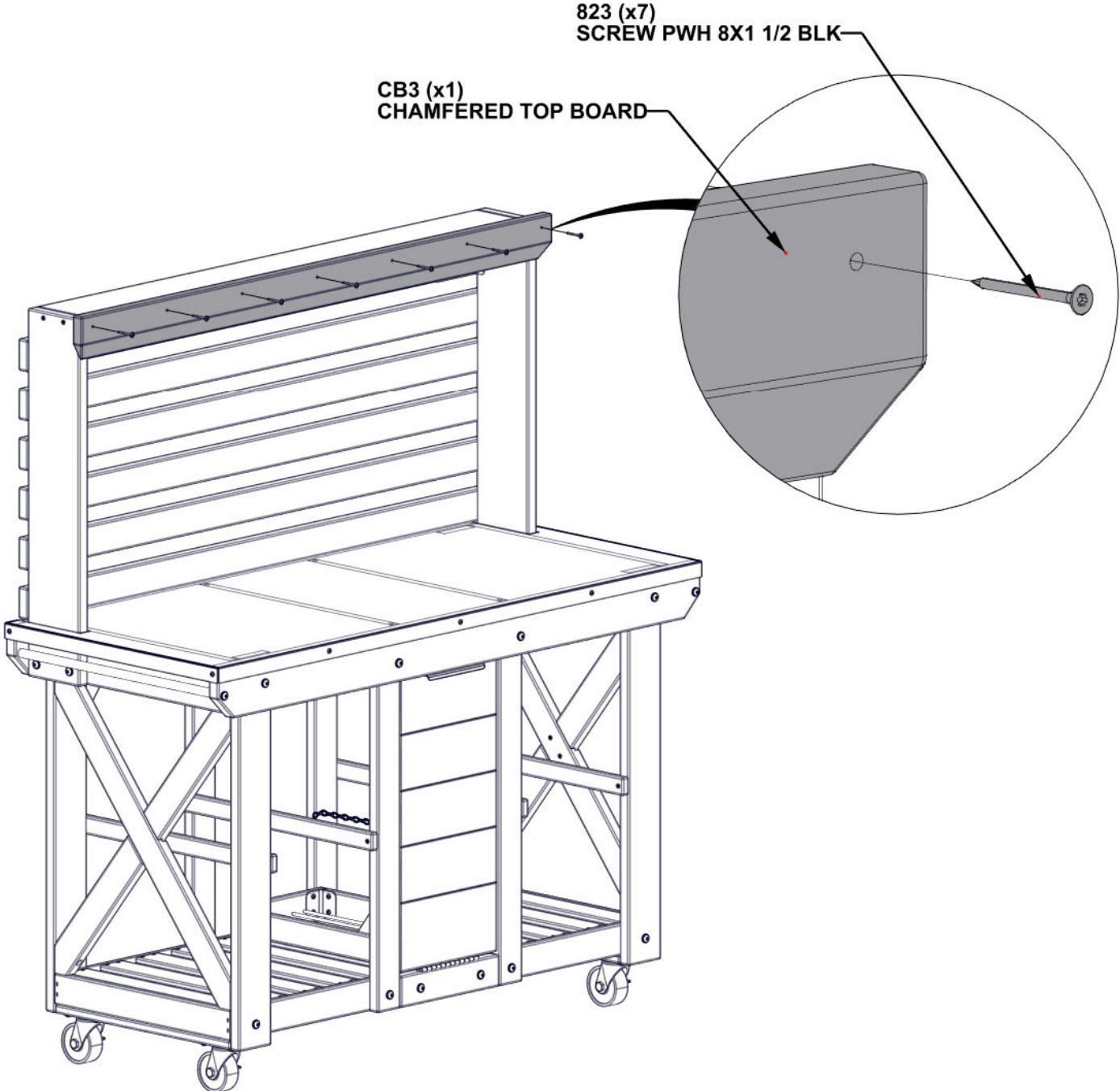

# STEP 24 - SHELF BOARD ASSEMBLY

Qty	Part No	Description
12	H100411	SCREW PFH 8x5/8 BLK



SB2-SHELF BOARD - W4L18910  
(x3) 15/16"x5 1/4"x22 7/16" (24x134x570)

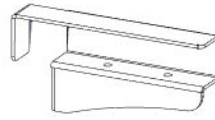

SHELF SUPPORT RIGHT - A4M02546  
(x3)

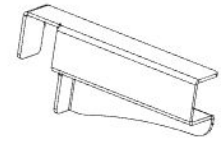

SHELF SUPPORT LEFT - A4M02547  
(x3)

- ALIGN PILOT HOLES.

**REPEAT THIS STEP 3 TIMES**

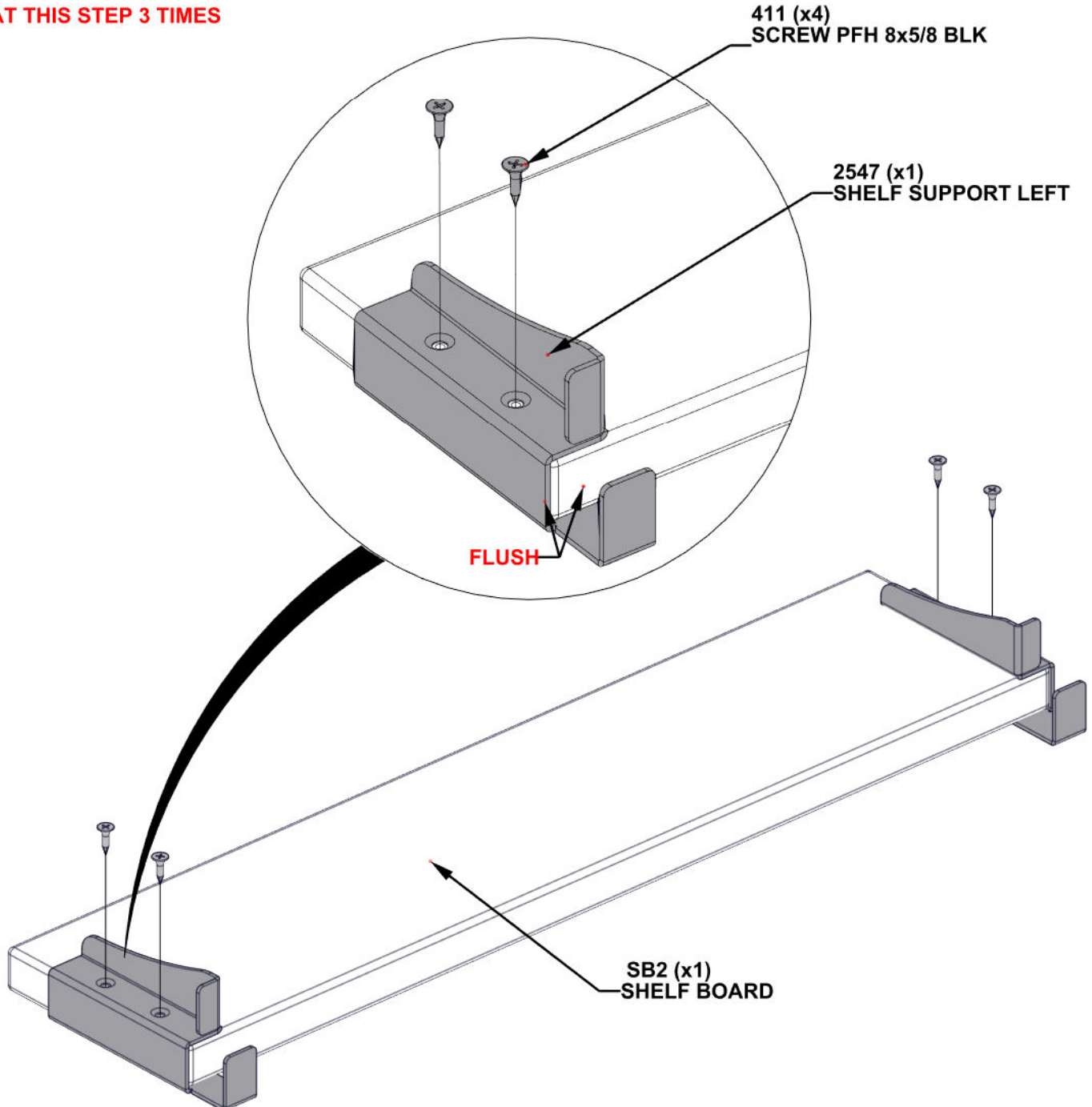

# STEP 25 - SHELF BOARD ASSEMBLY

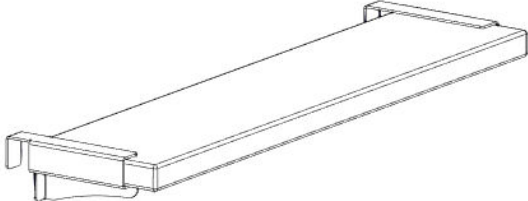

SHELF BOARD ASSEMBLY - STEP 24

- INSERT SHELVES IN DESIRED LOCATION AS SHOWN.

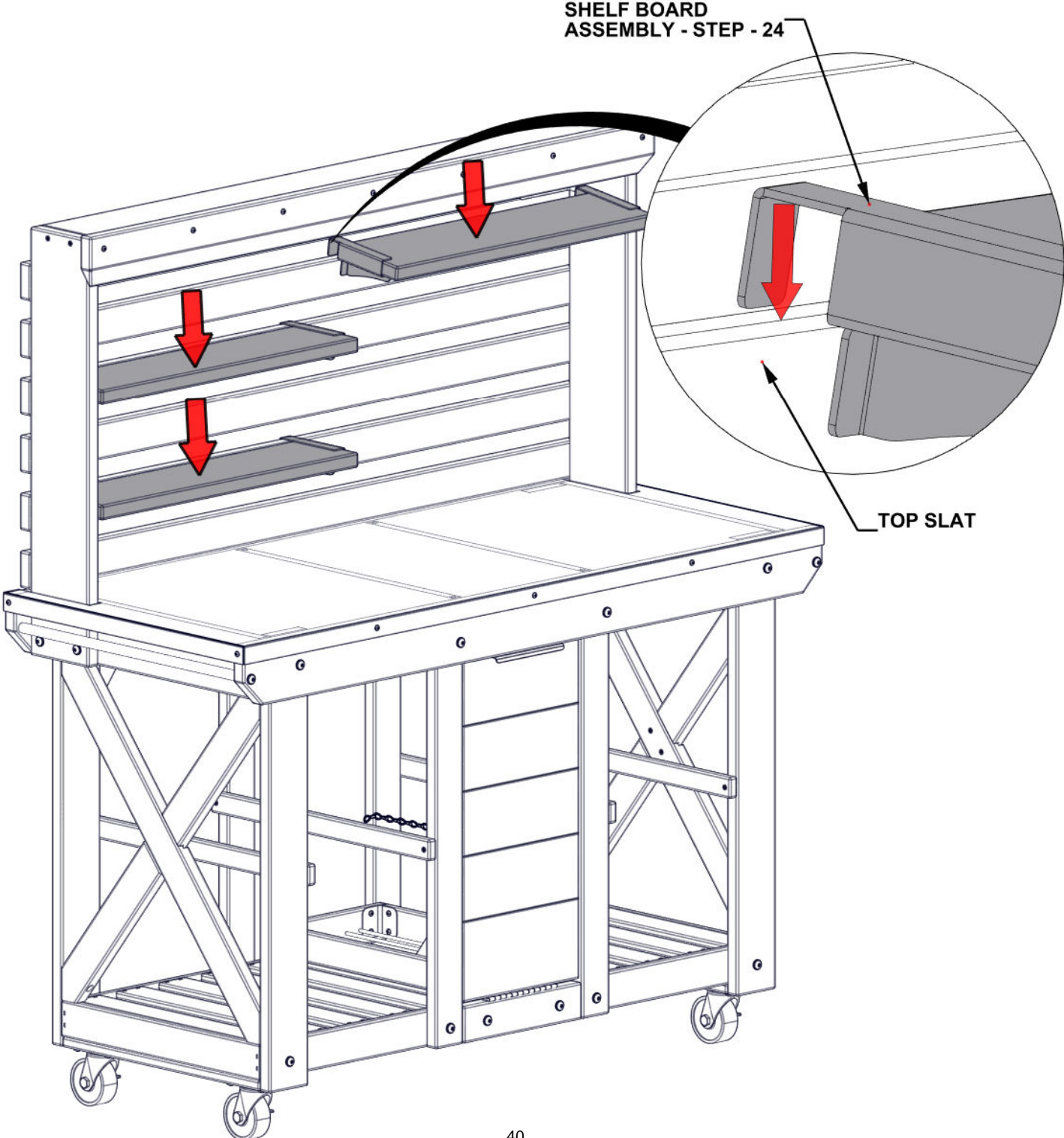

# STEP 26 - HOOK ASSEMBLY

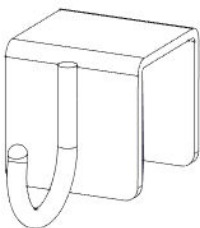

HOOK - A4M02548  
(x3)

- INSERT 3 HOOKS IN DESIRED LOCATION.

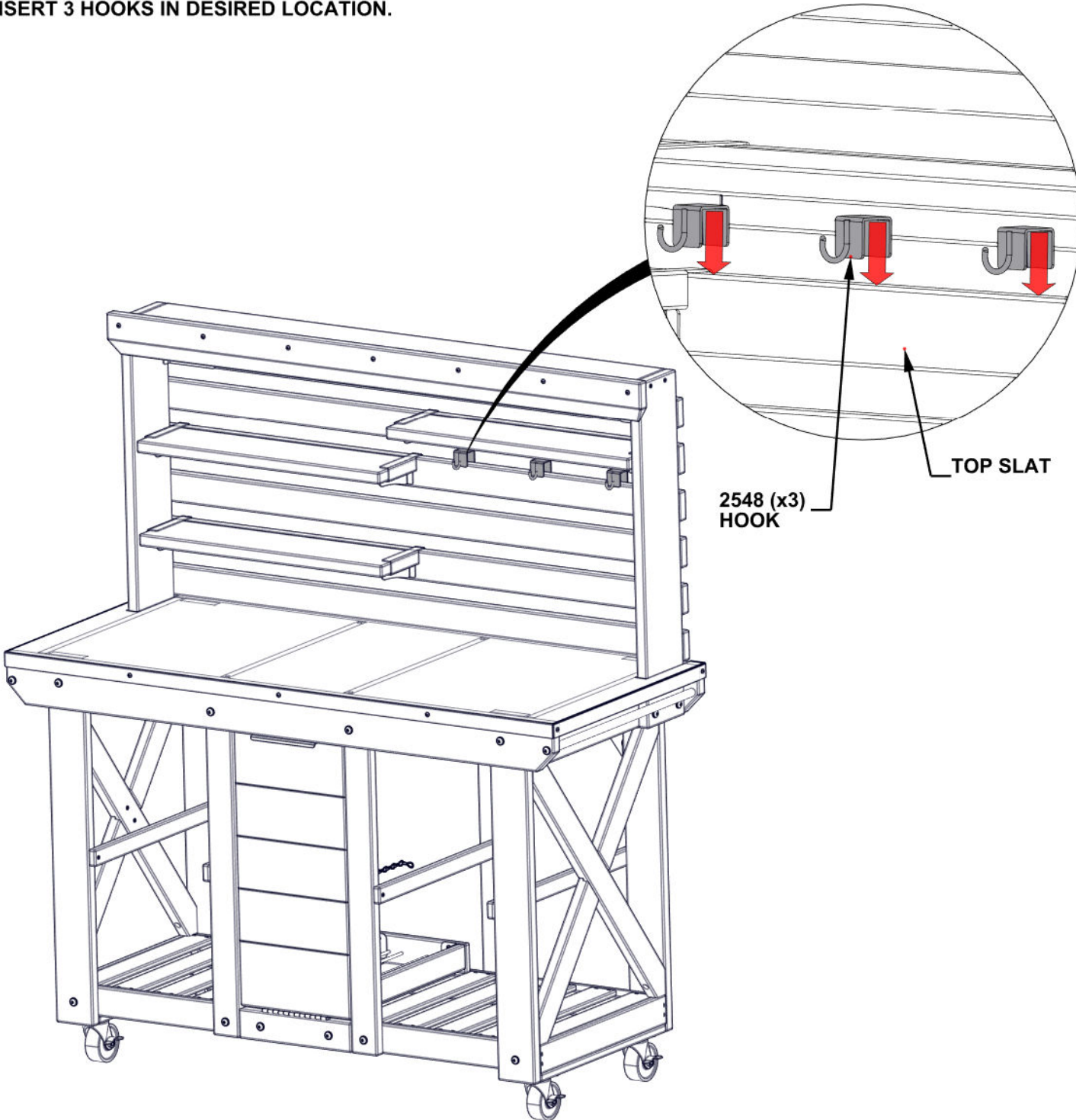

# STEP 27A - WINE RACK ASSEMBLY

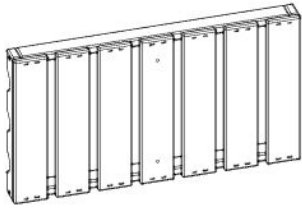

WR1-WINE RACK ASSY - W2A04016  
(x2) 1 13/16"x11 1/8"x19 15/16" (46x283x506)



BH1-BOTTLE HOLD BOARD - W4L21182  
(x2) 5/8"x2 3/8"x9 15/16" (16x60x250)

Qty	Part No	Description
4	H100816	SCREW PFH 8x7/8 BLK

- ALIGN PILOT HOLES.

**REPEAT THIS STEP 2 TIMES**

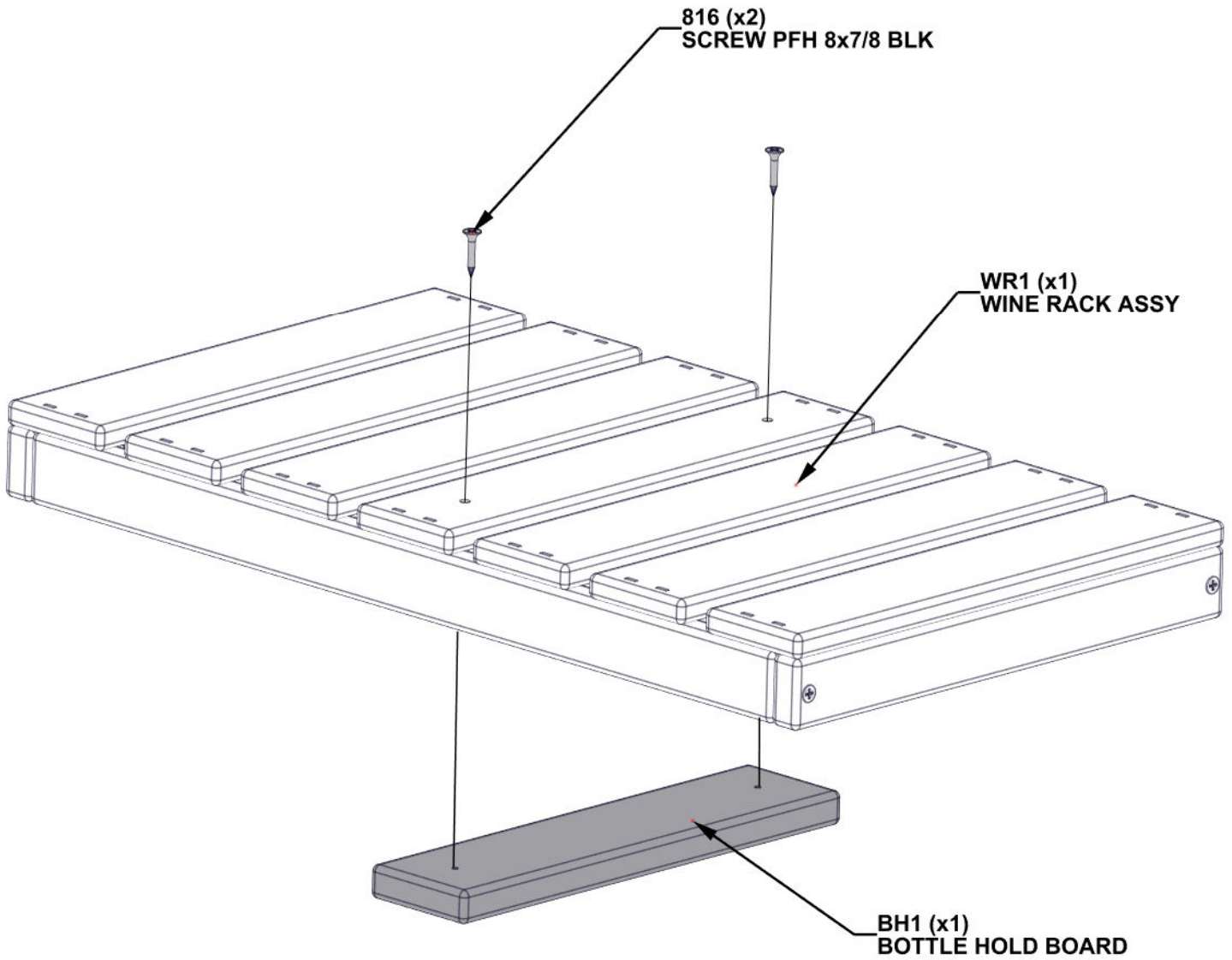

# STEP 27B - WINE RACK ASSEMBLY

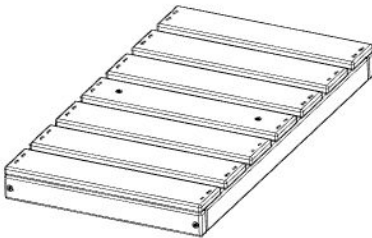

WINE RACK ASSEMBLY - STEP 27A

- INSERT 2 WINE RACKS ONTO SUPPORT BOARD IN DESIRED ORIENTATION.

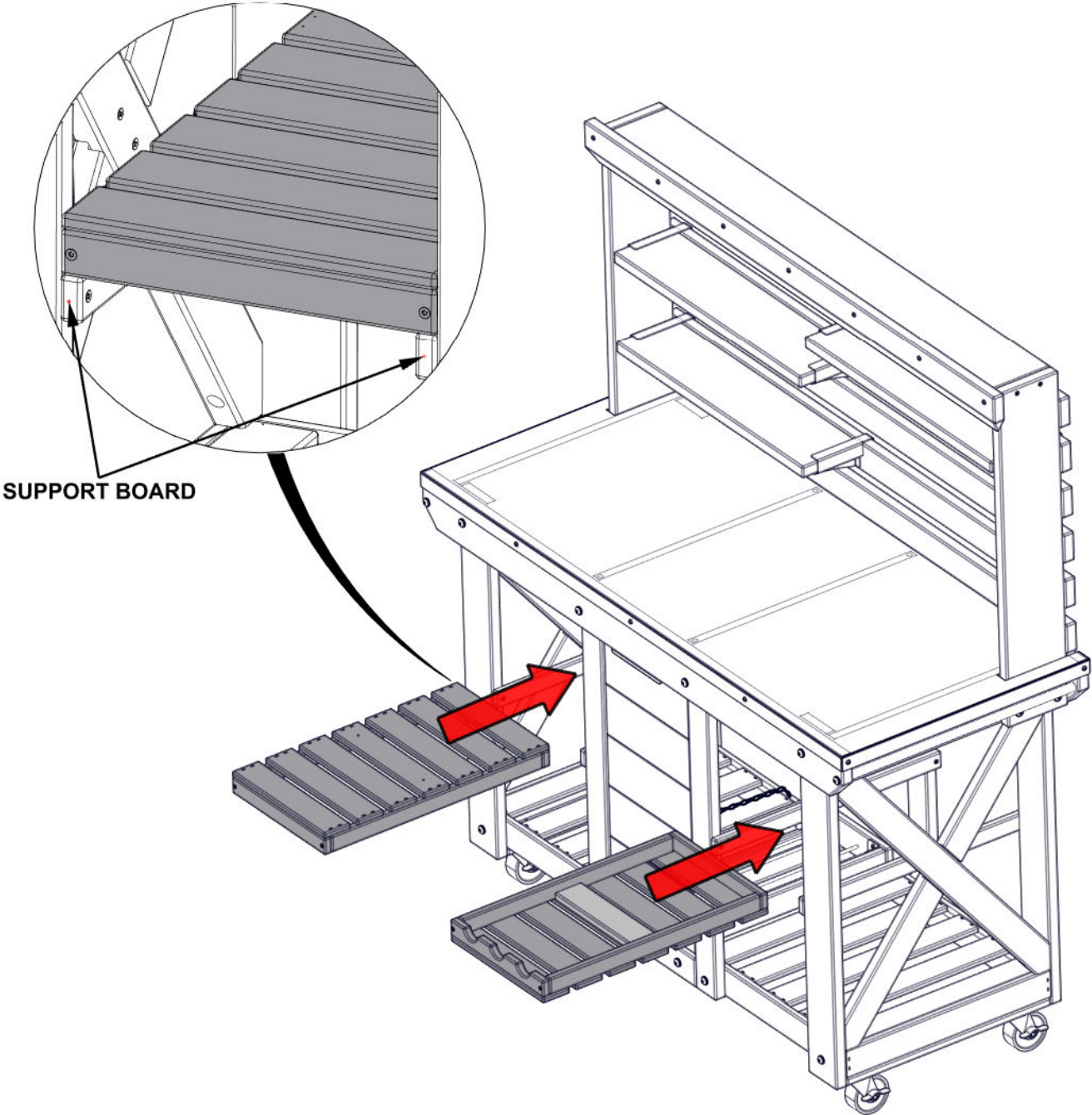

# STEP 28 - BOTTLE CAP OPENER ASSEMBLY



BOTTLE CAP OPENER - A4M01187  
(x1)

Qty	Part No	Description
2	H100816	SCREW PFH 8x7/8 BLK

- BEFORE INSTALLING SCREWS, PRE-DRILL LOCATIONS SHOWN USING A 1/8" (3mm) DRILL BIT.

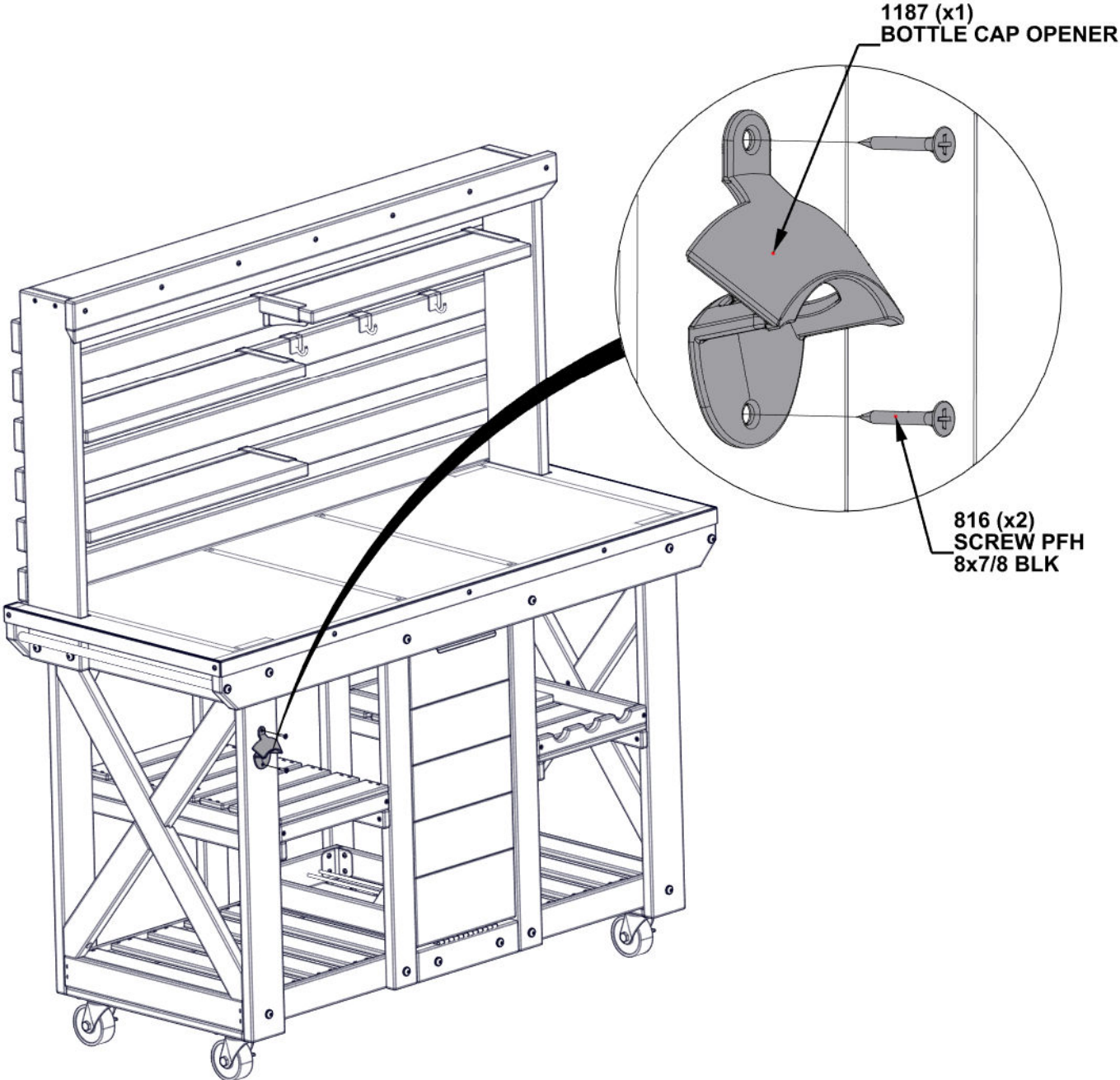

# STEP 29 - BYD ID TAG PATIO ASSEMBLY



Qty	Part No	Description
4	H100392	SCREW PWH 8X3/4 BLK

BYD ID TAG PATIO - A4M02158  
(x1)

- CENTER ID TAG ON FRONT OF BOTTOM PANEL AS SHOWN.
- BEFORE INSTALLING SCREWS, PRE-DRILL LOCATIONS SHOWN USING A 1/8" (3mm) DRILL BIT.

