

# ASSEMBLY INSTRUCTION

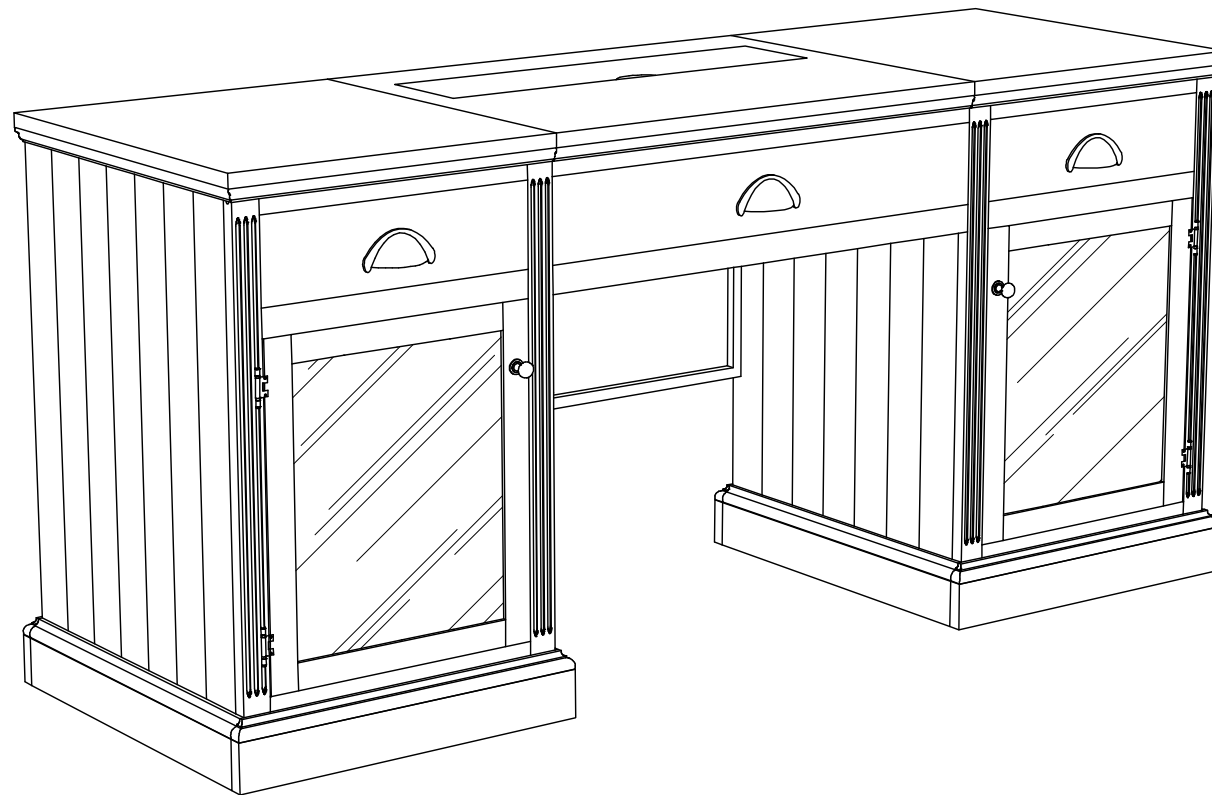

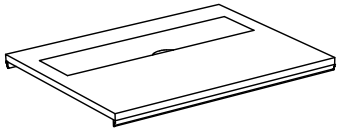

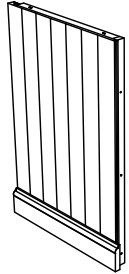

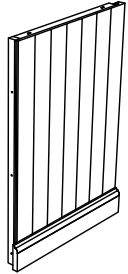
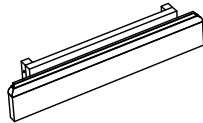
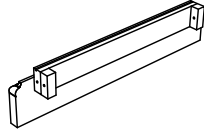
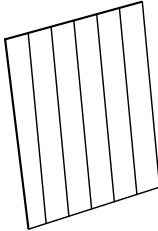
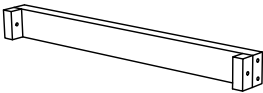
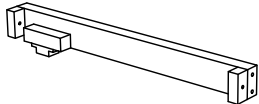
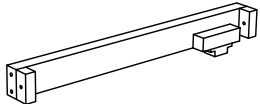
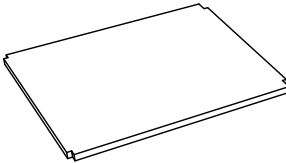
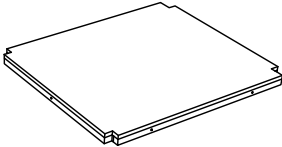
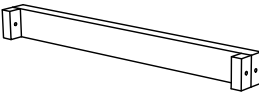
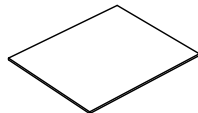
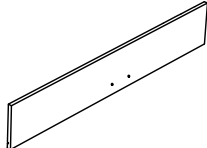
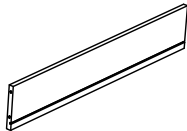
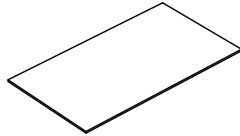

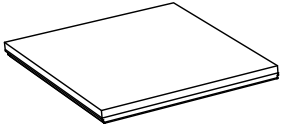
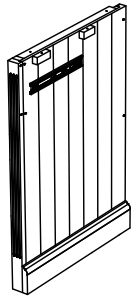
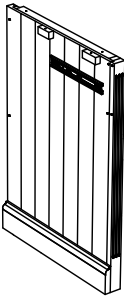
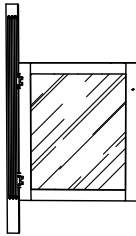
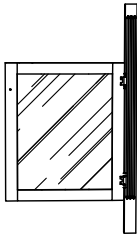
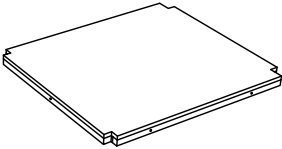
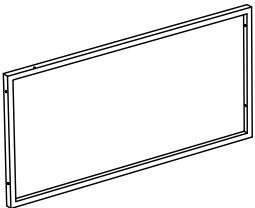
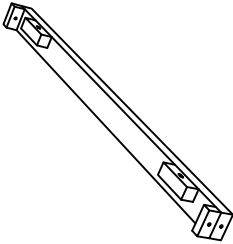
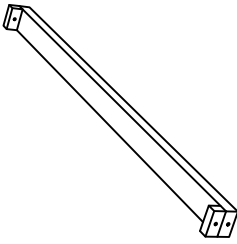
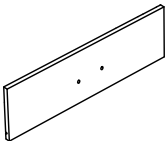
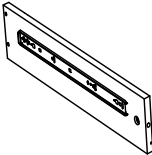
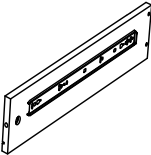
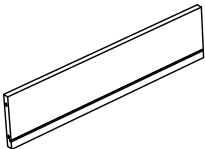
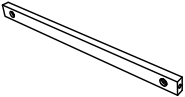
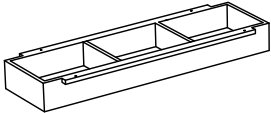
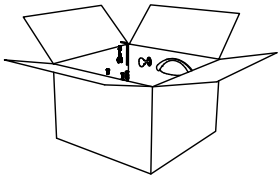

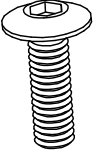
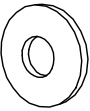

# PARTS LIST

<p>2</p>  <p>Center table top 1 pc</p>	<p>3</p>  <p>Left outer hip cluster 1 pc</p>	<p>6</p>  <p>Right outer hip cluster 1 pc</p>	<p>9</p>  <p>Front lower crossbar 2 pcs</p>	<p>10</p>  <p>Bottom bar behind 2 pcs</p>	<p>11</p>  <p>Back plate 2 pcs</p>
<p>12</p>  <p>Front upper bar 2 pcs</p>	<p>13</p>  <p>Front middle bar left 1 pc</p>	<p>14</p>  <p>Front middle bar right 1 pc</p>	<p>15</p>  <p>Middle plate 2 pcs</p>	<p>16</p>  <p>Bottom plate 1 pc</p>	<p>17</p>  <p>Rear top bar 2 pcs</p>
<p>25</p>  <p>Drawer bottom plate 2 pcs</p>	<p>26</p>  <p>Middle drawer face 1 pc</p>	<p>27</p>  <p>Middle drawer back 1 pc</p>	<p>29</p>  <p>Middle drawer bottom plate 1 pc</p>		

# PARTS LIST

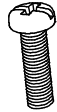
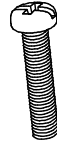
<p>1</p>  <p>Left and right table top 2 pcs</p>	<p>4</p>  <p>Left inner hip cluster 1 pc</p>	<p>5</p>  <p>Right inner hip cluster 1 pc</p>	<p>7</p>  <p>Left door cluster 1 pc</p>	<p>8</p>  <p>Right door cluster 1 pc</p>	<p>16</p>  <p>Bottom plate 1 pc</p>
<p>18</p>  <p>Middle posterior cluster 1 pc</p>	<p>19</p>  <p>Front middle upper strut 1 pc</p>	<p>20</p>  <p>Front lower center strut 1 pc</p>	<p>21</p>  <p>Drawer face 2 pcs</p>	<p>22</p>  <p>Left side drawer panel 3 pcs</p>	<p>23</p>  <p>Right side drawer panel 3 pcs</p>
<p>24</p>  <p>Drawer back 2 pcs</p>	<p>28</p>  <p>Drawer bottom support 1 pc</p>	<p>30</p>  <p>Socket mounting box 1 pc</p>	 <p><b>HARDWARE</b></p>		

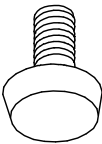
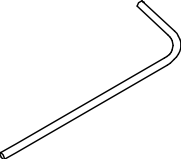
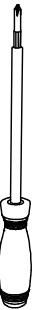
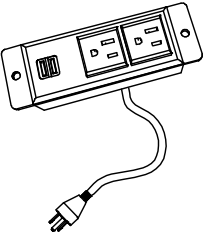
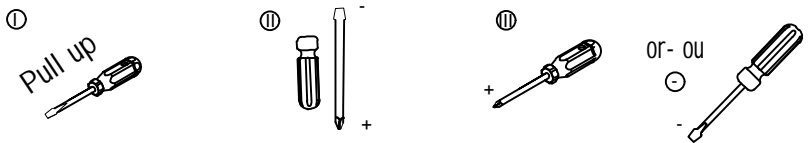
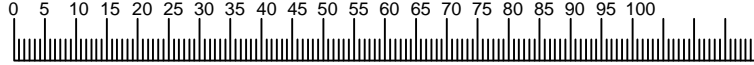
# HARDWARE LIST

<p><b>A</b></p>  <p>6x30mm Bolt (64 pcs)</p>	<p><b>B</b></p>  <p>6x16mm Washer (56 pcs)</p>	<p><b>C</b></p>  <p>8x30mm Dowel (36 pcs)</p>	<p><b>D</b></p>  <p>4x25mm Screw (20 pcs)</p>	<p><b>E</b></p>  <p>3x10mm Screw (2 pcs)</p>	<p><b>F</b></p>  <p>Cam lock pin (8 pcs)</p>	<p><b>G</b></p>  <p>Cam lock (8 pcs)</p>
<p><b>H</b></p>  <p>4x15mm Bolt (6 pcs)</p>	<p><b>I</b></p>  <p>4x25mm Bolt (2 pcs)</p>	<p><b>J</b></p>  <p>Handle (2 pcs)</p>	<p><b>K</b></p>  <p>Clam shell handle (3 pcs)</p>	<p><b>L</b></p>  <p>Height adjuster (8 pcs)</p>	<p><b>M</b></p>  <p>Allen key (1 pc)</p>	<p><b>N</b></p>  <p>Screwdrivers (1 pc)</p>
<p><b>O</b></p>  <p>Power outlet (1pc)</p>	<p><b>Tool required</b></p>  <p>Pull up</p> <p>Screwdrivers can be converted to philips and Slotted</p> <p>Ruler - Use this ruler to help correctly identify the screws</p>  <p>The crews length is measured from the head to th point (35mm screw shown)</p> 					

# COMPONENTS - KEY DIAGRAM

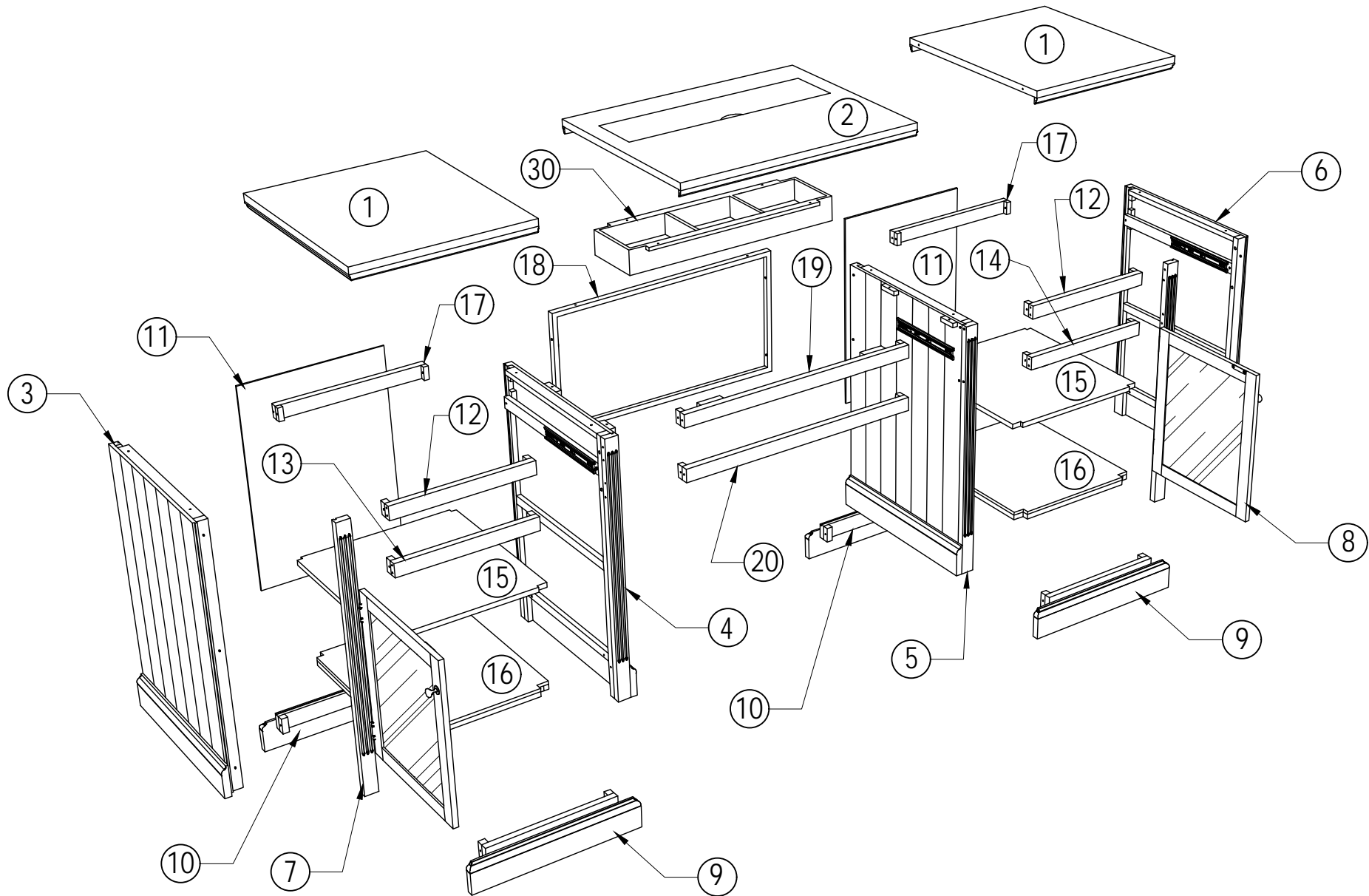

# COMPONENTS - KEY DIAGRAM

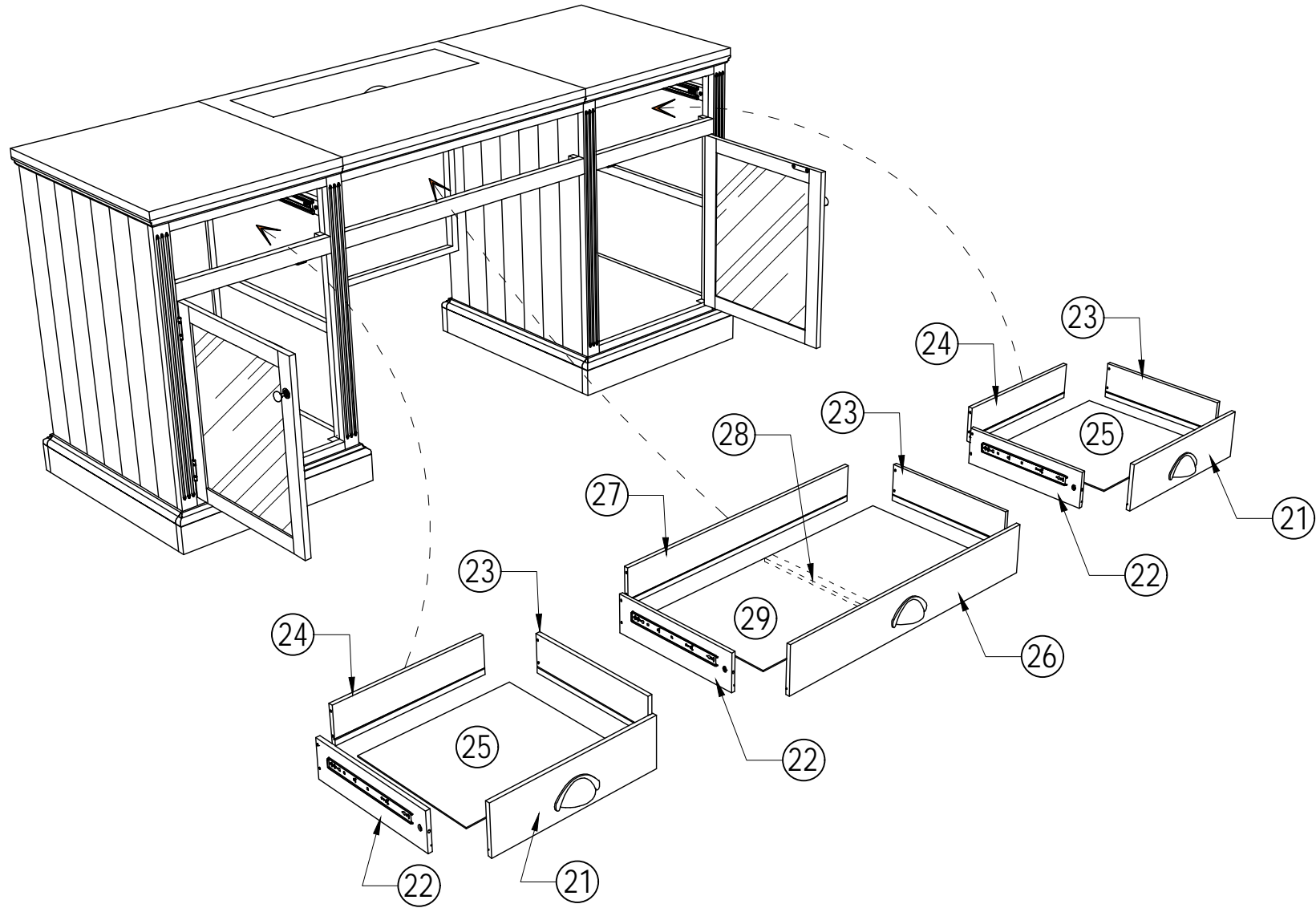

# STEP 1

A

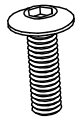

6x30mm  
3 pcs

B



6x16mm  
3 pcs

M

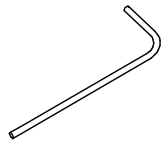

1 pc

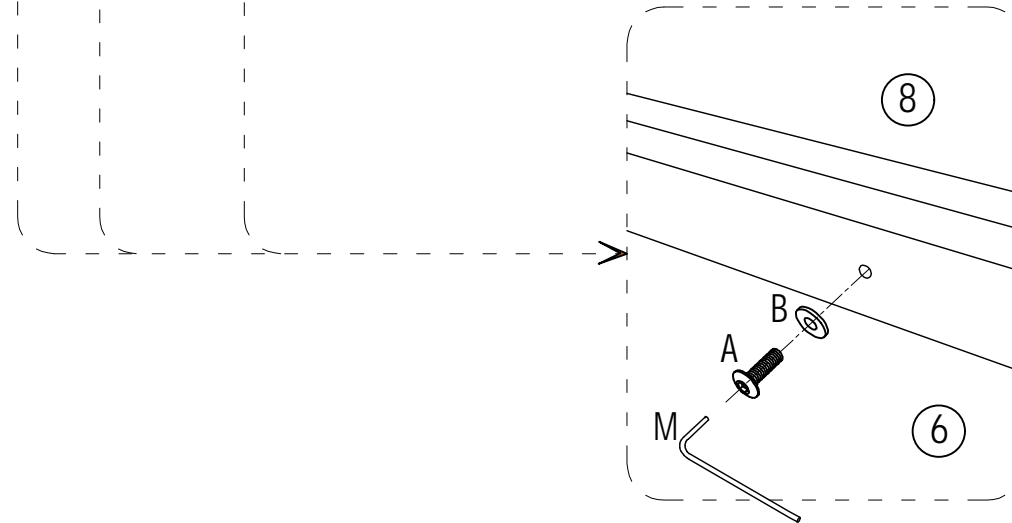
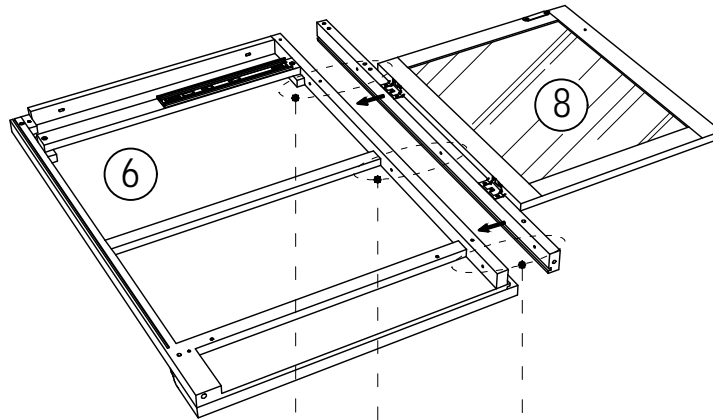

# STEP 2

(A)

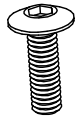

6x30mm  
3 pcs

(B)



6x16mm  
2 pcs

(C)



8x30mm  
5 pcs

(M)

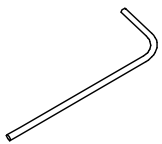

1 pc

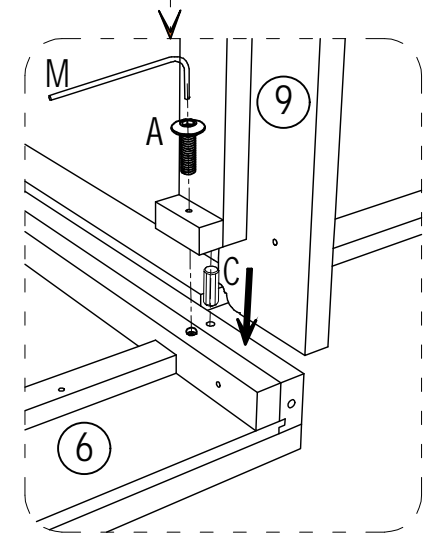
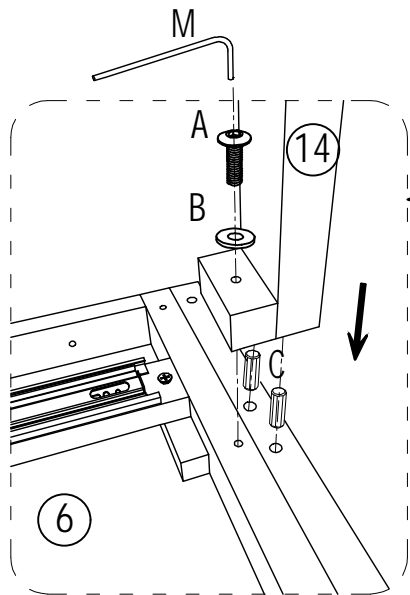
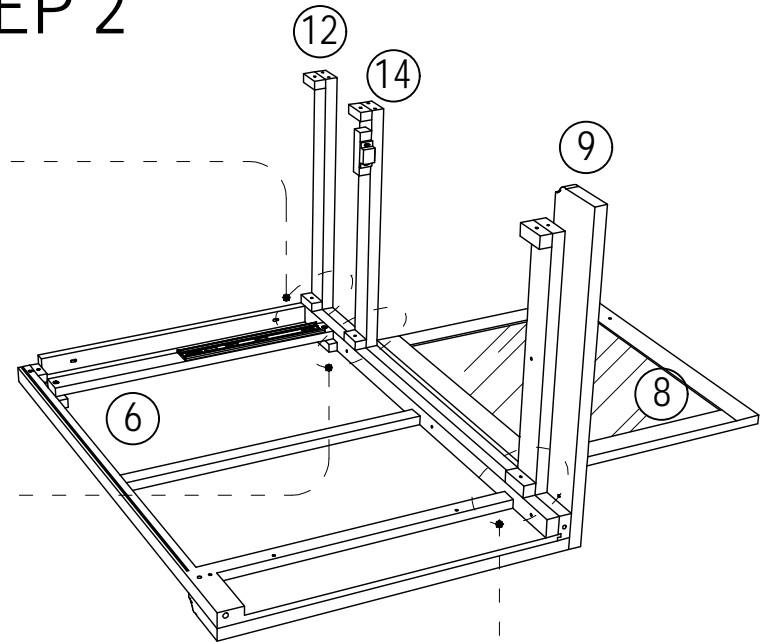
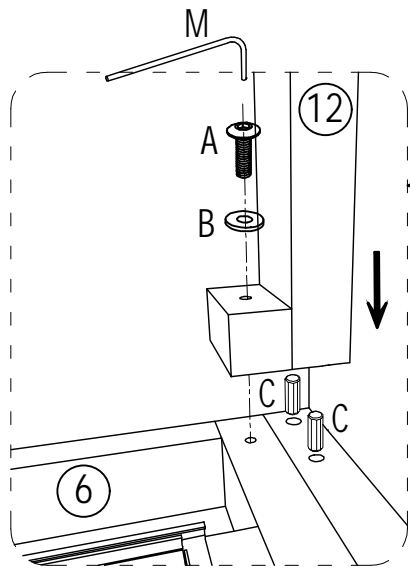

# STEP 3

(A)

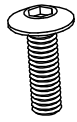

6x30mm  
2 pcs

(B)



6x16mm  
1 pc

(C)



8x30mm  
2 pcs

(M)

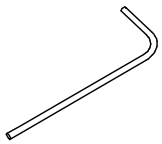

1 pc

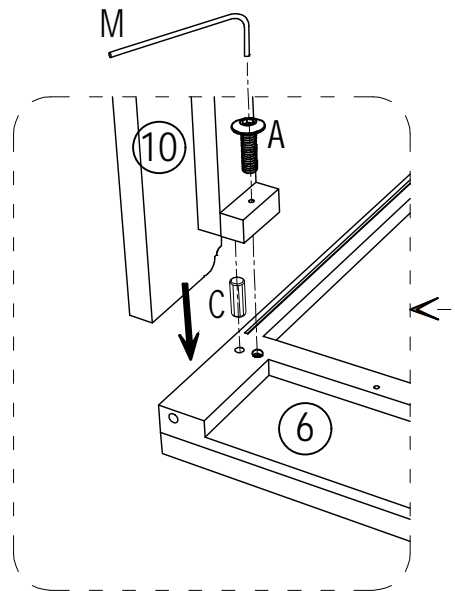
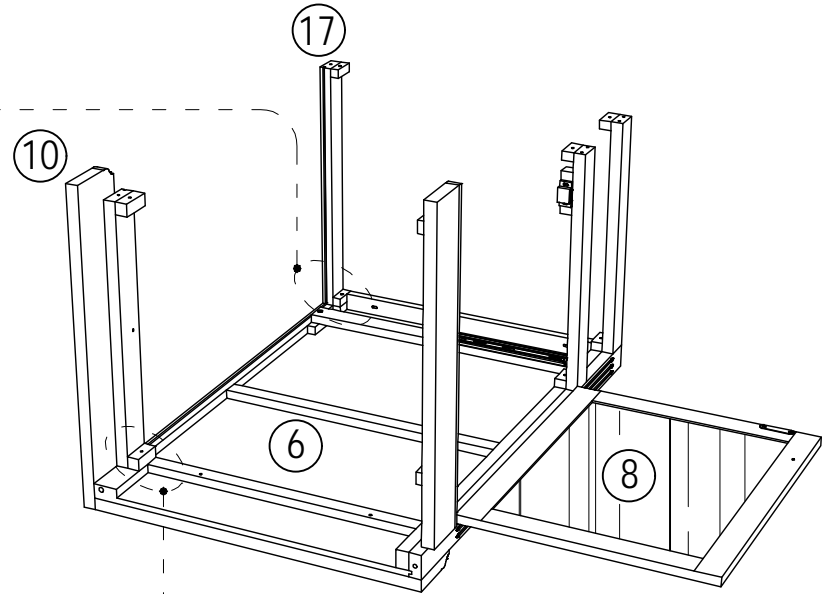
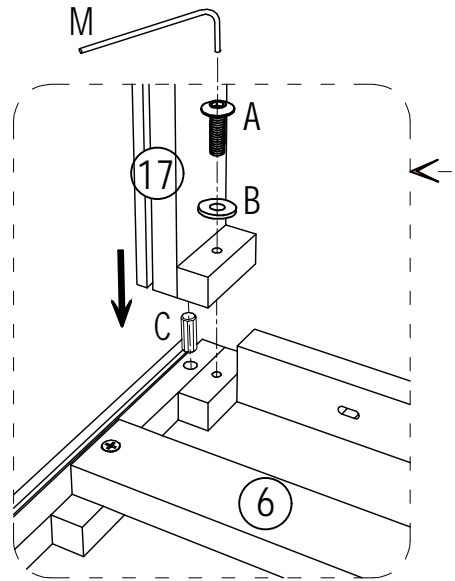

# STEP 4

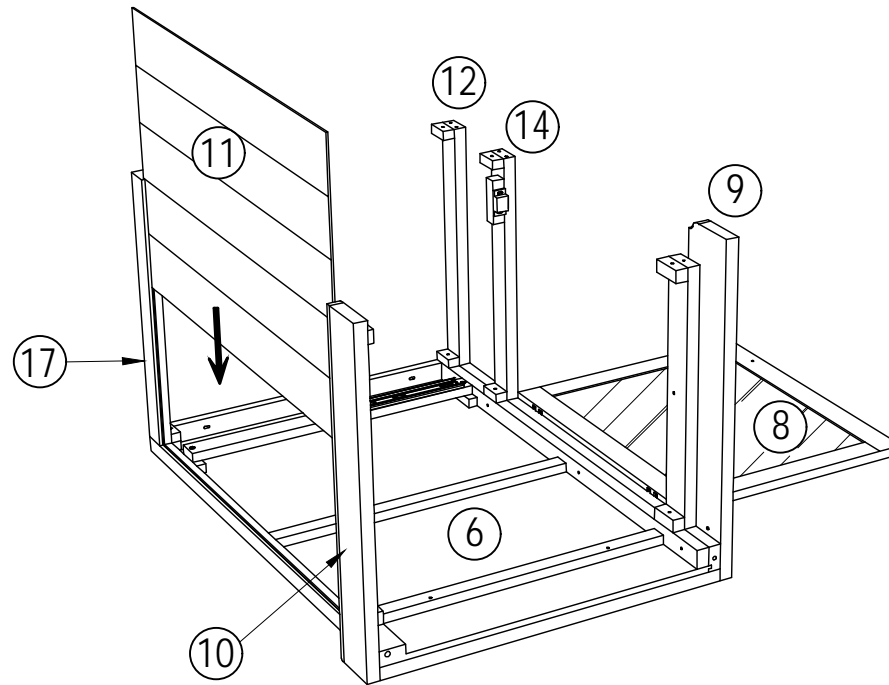

# STEP 5

(A)

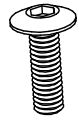

6x30mm  
2 pcs

(B)



6x16mm  
1 pc

(C)



8x30mm  
2 pcs

(M)

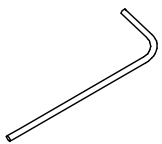

1 pc

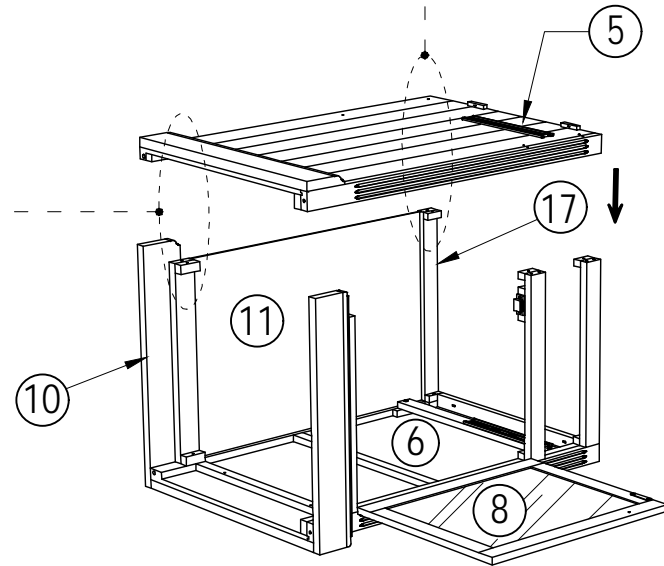
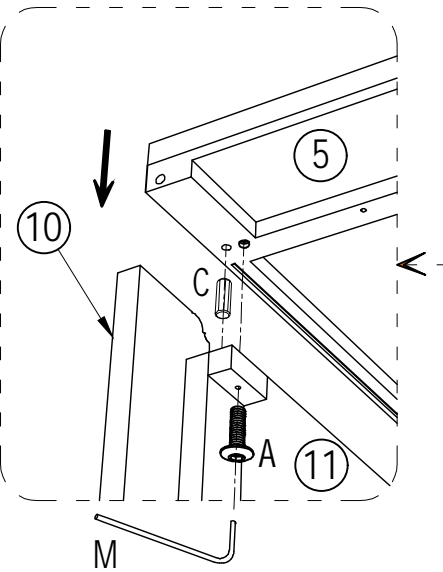
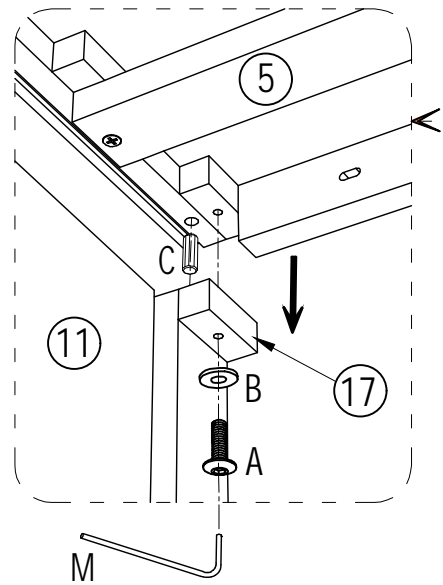

# STEP 6

(A)

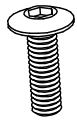

6x30mm  
3 pcs

(B)



6x16mm  
2 pcs

(C)



8x30mm  
5 pcs

(M)

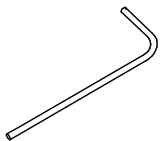

1 pc

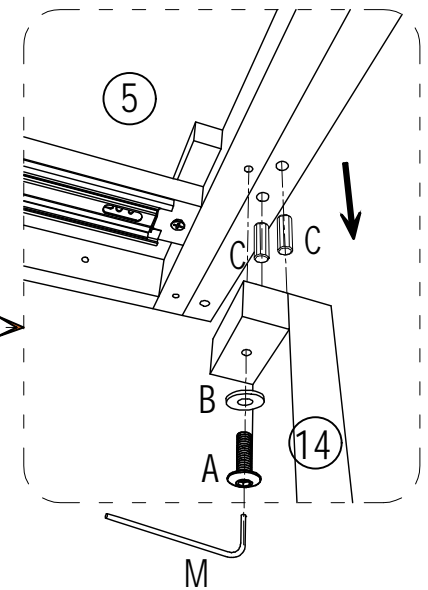
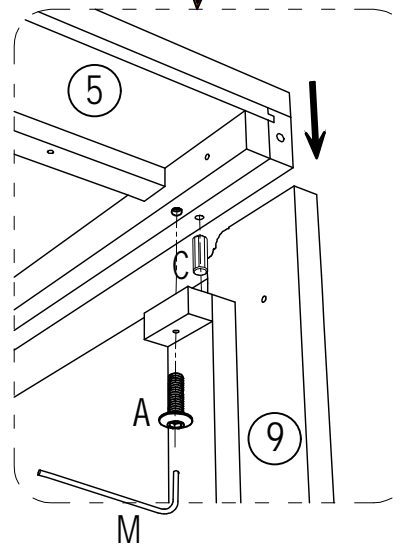
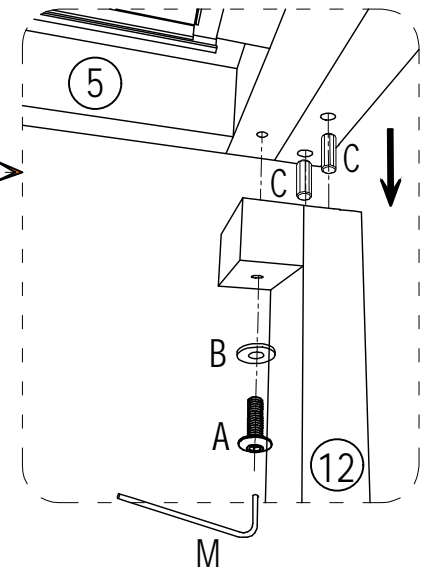
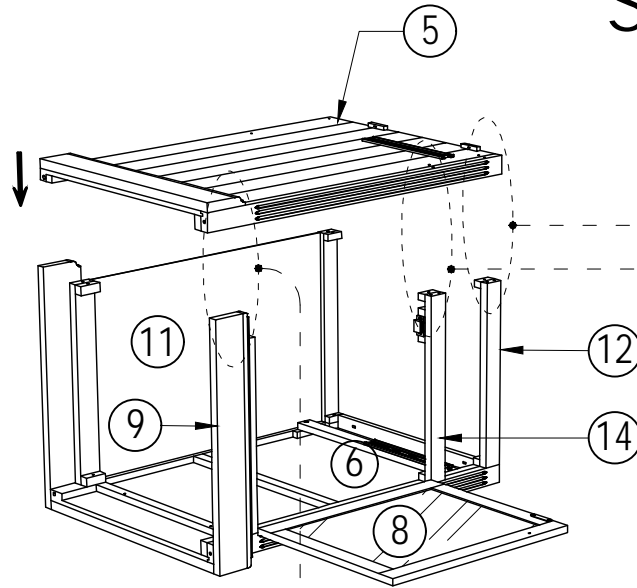

# STEP 7

(A)

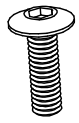

6x30mm  
5 pcs

(B)



6x16mm  
5 pcs

(M)

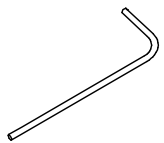

1 pc

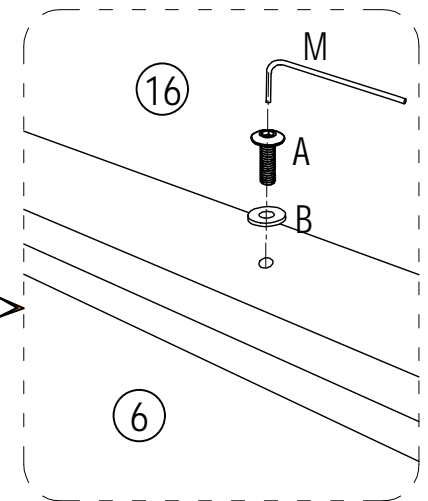
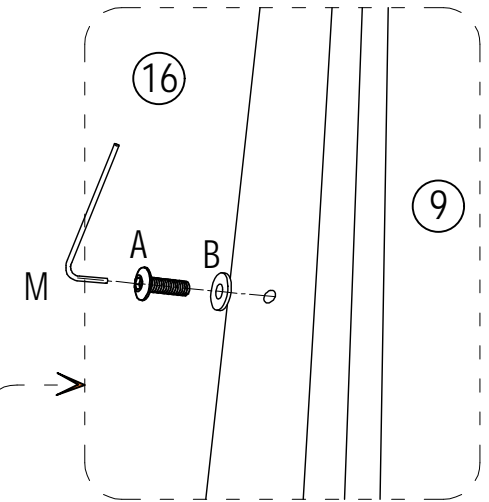
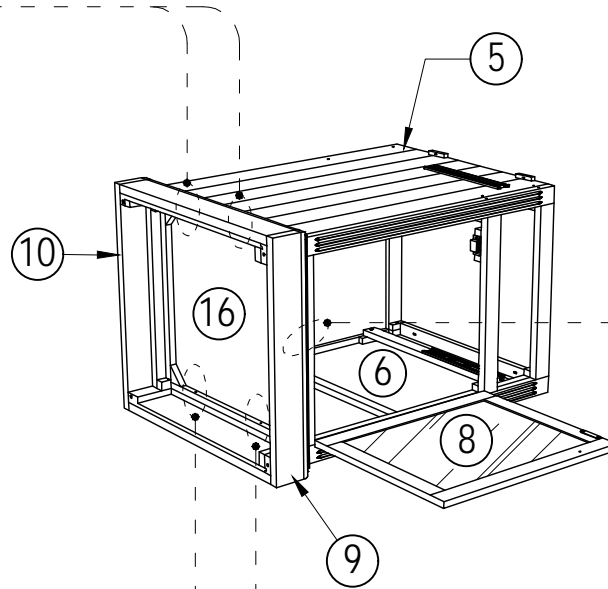
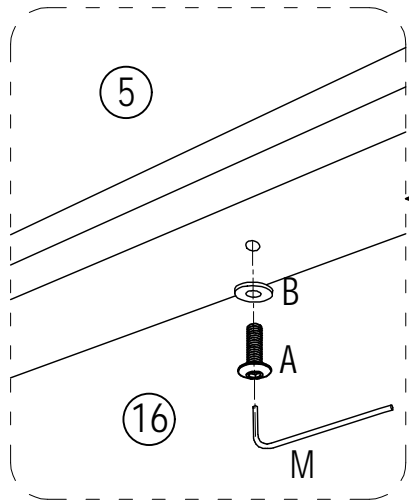

# STEP 8

L



4 pcs

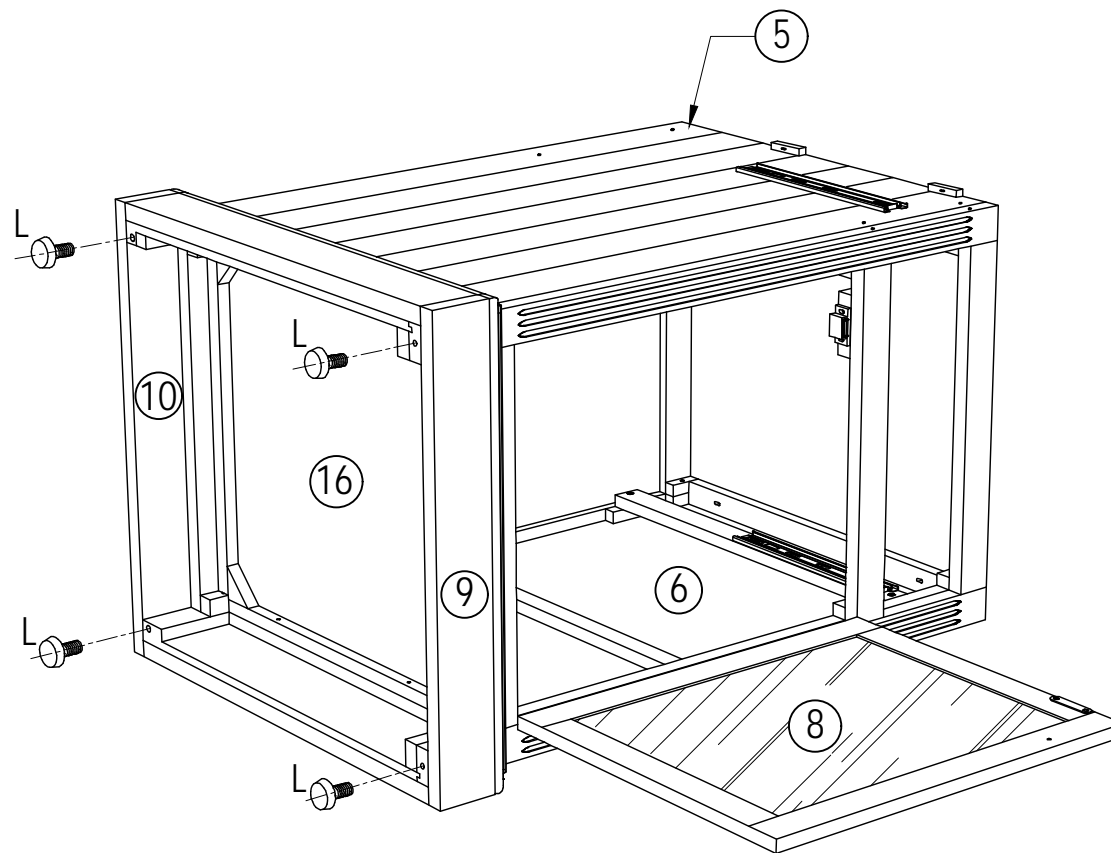

# STEP 9

(D)



4x25mm  
4 pcs

(I)

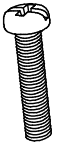

4x25mm  
1 pc

(J)

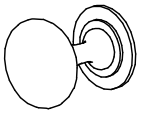

1 pc

(N)

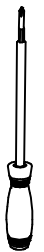

1 pc

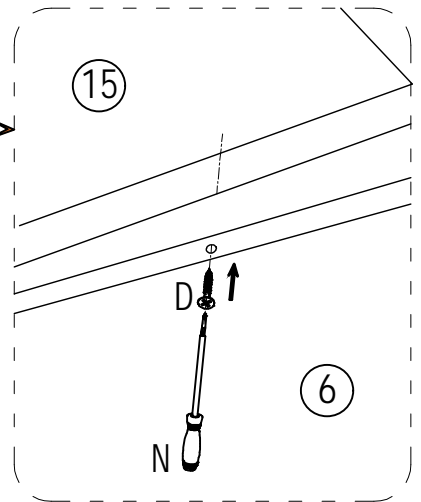
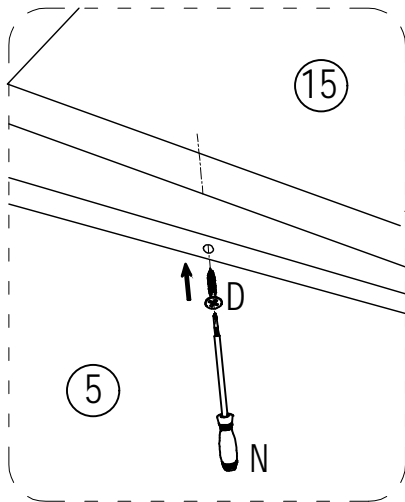
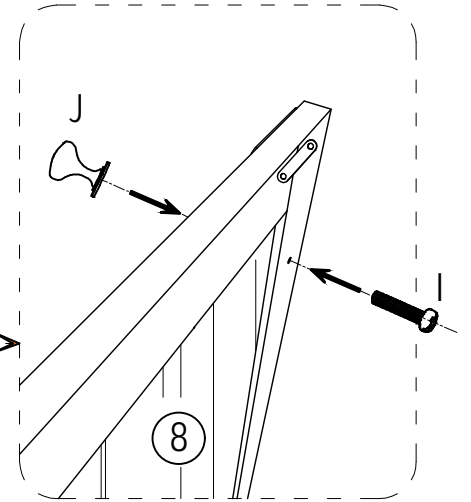
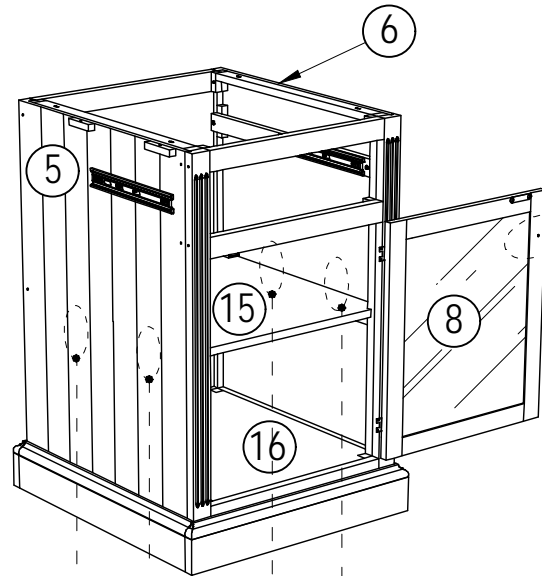

# STEP 10

A

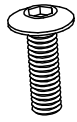

6x30mm  
3 pcs

B



6x16mm  
3 pcs

M

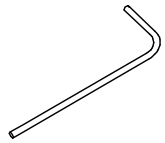

1 pc

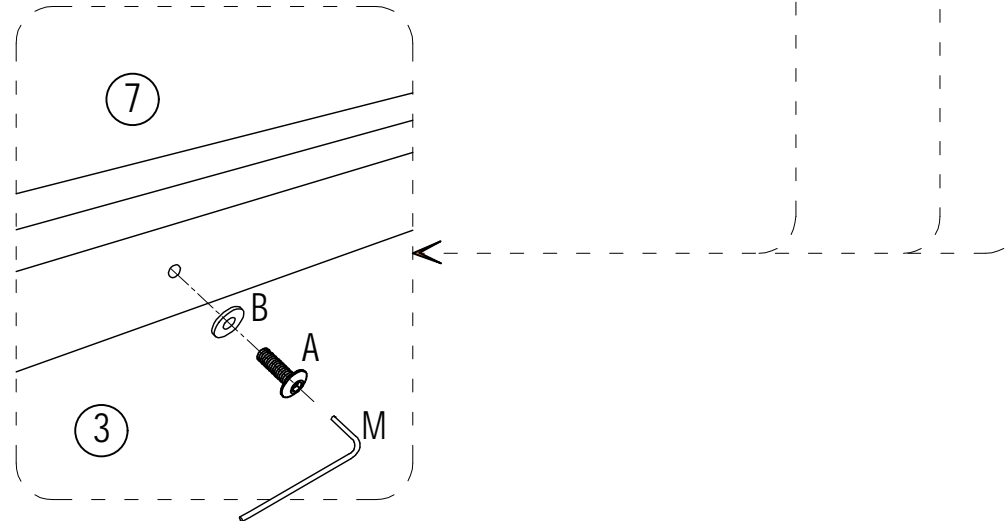
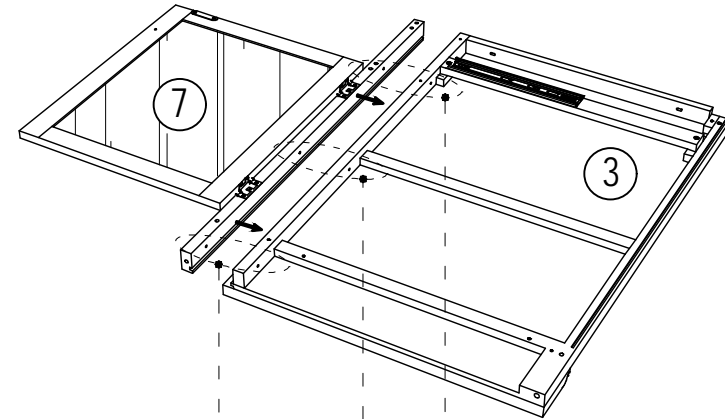

# STEP 11

(A)

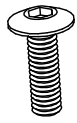

6x30mm  
3 pcs

(B)



6x16mm  
2 pcs

(C)



8x30mm  
5 pcs

(M)

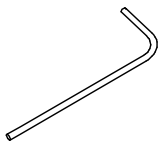

1 pc

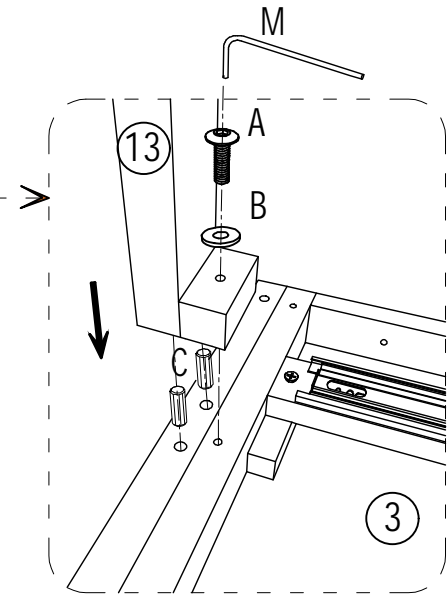
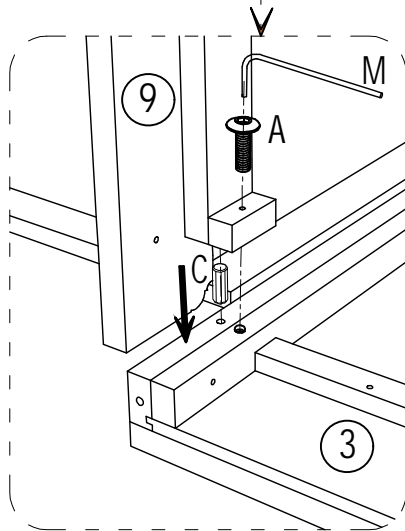
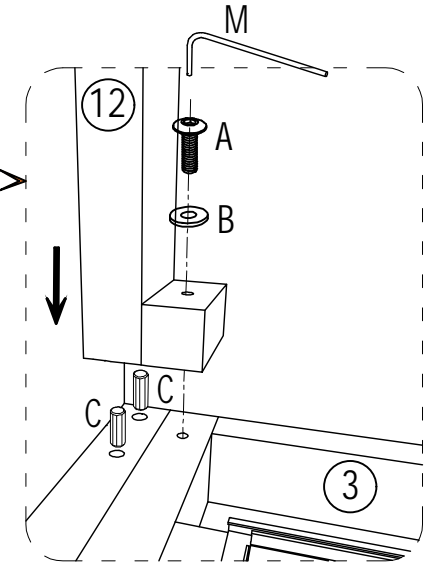
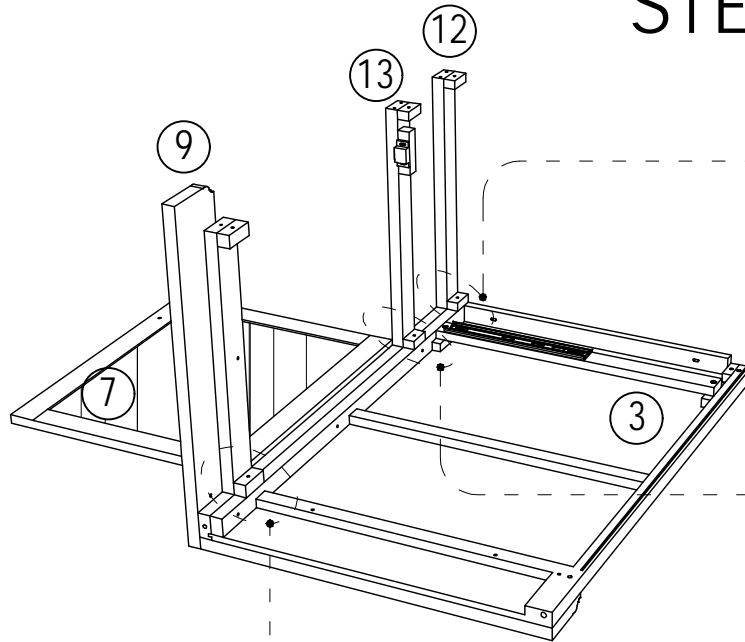

# STEP 12

(A)

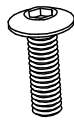

6x30mm  
2 pcs

(B)



6x16mm  
1 pc

(C)



8x30mm  
2 pcs

(M)

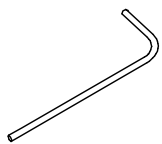

1 pc

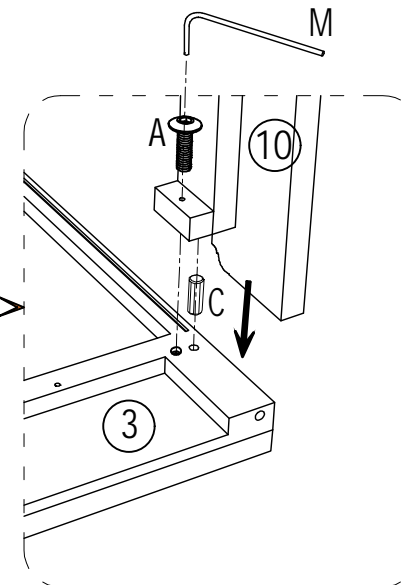
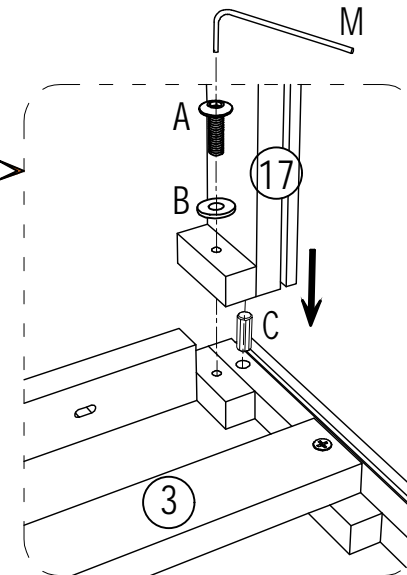
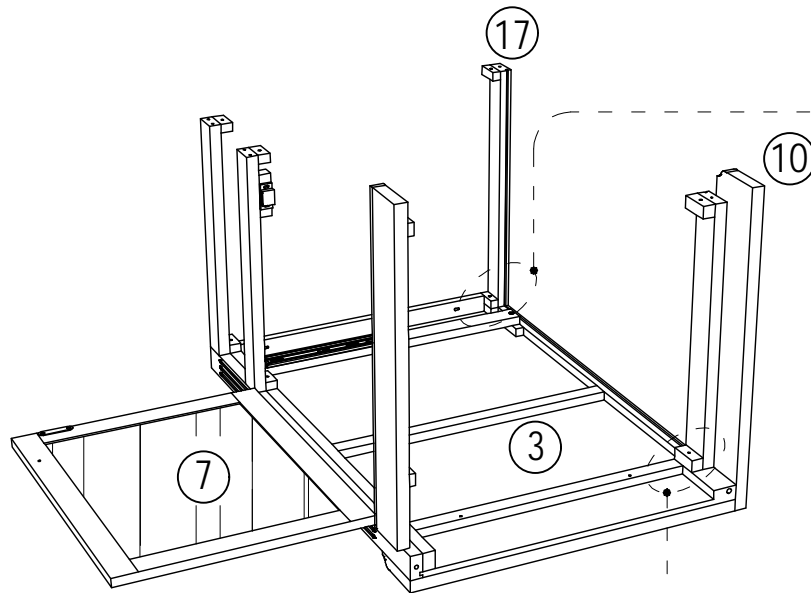

# STEP 13

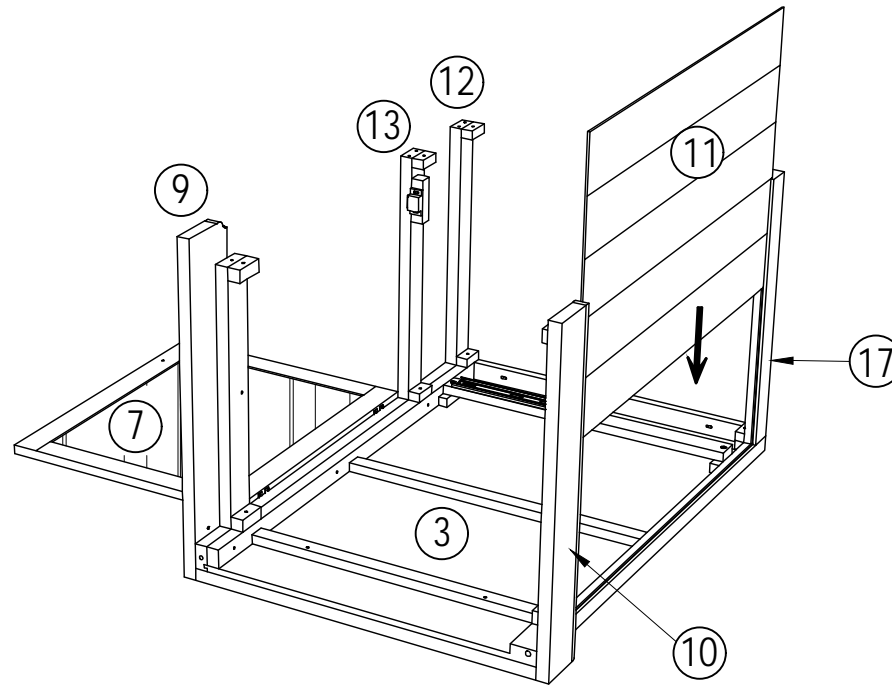

# STEP 14

(A)

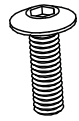

6x30mm  
2 pcs

(B)



6x16mm  
1 pc

(C)



8x30mm  
2 pcs

(M)

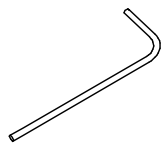

1 pc

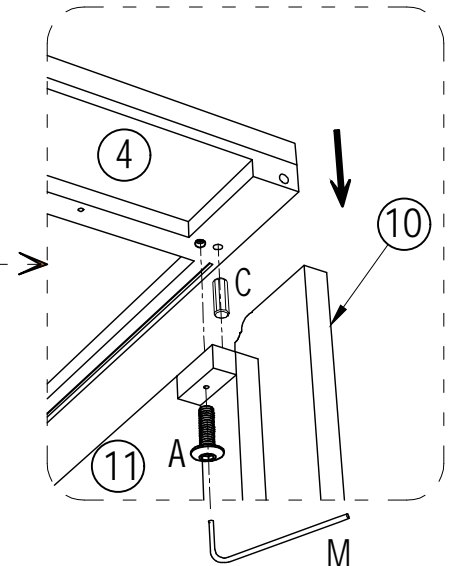
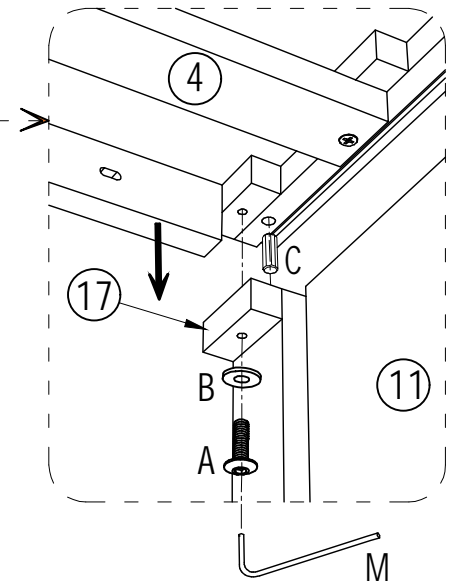
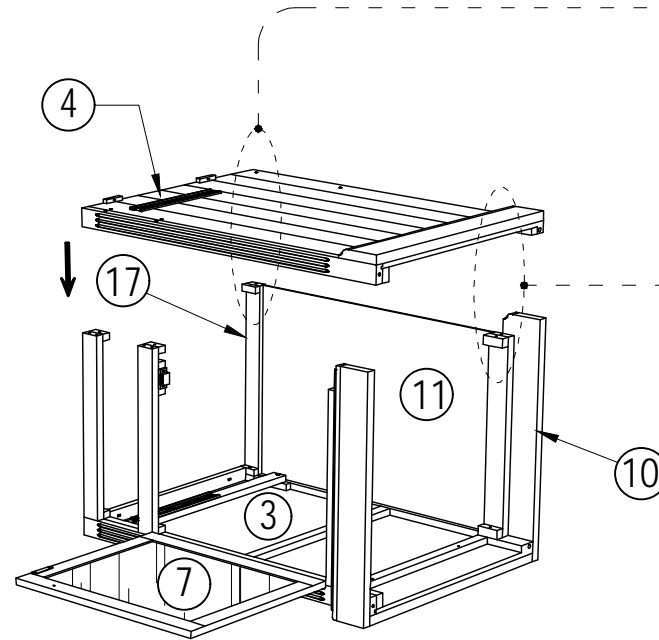

# STEP 15

(A)

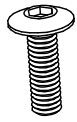

6x30mm  
3 pcs

(B)



6x16mm  
2 pcs

(C)



8x30mm  
5 pcs

(M)

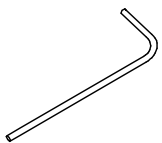

1 pc

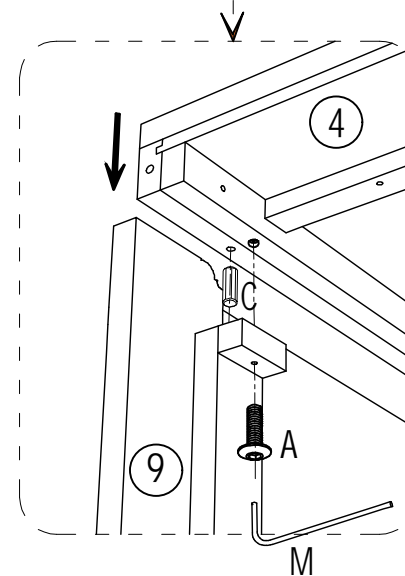
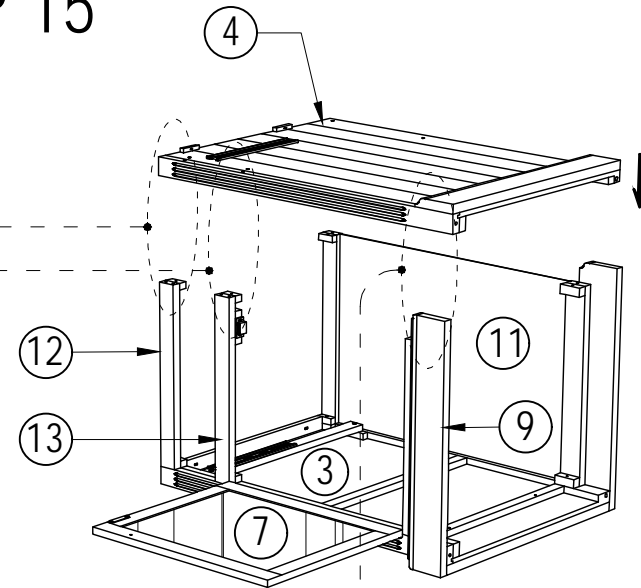
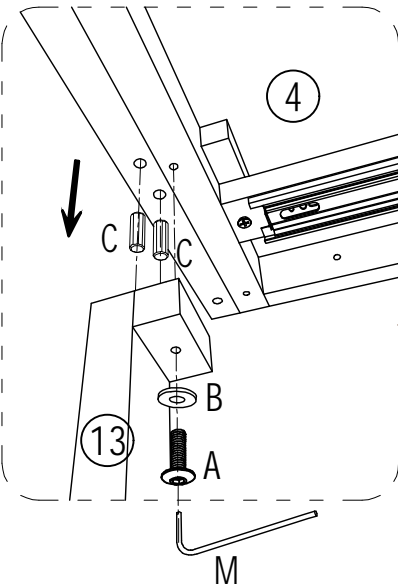
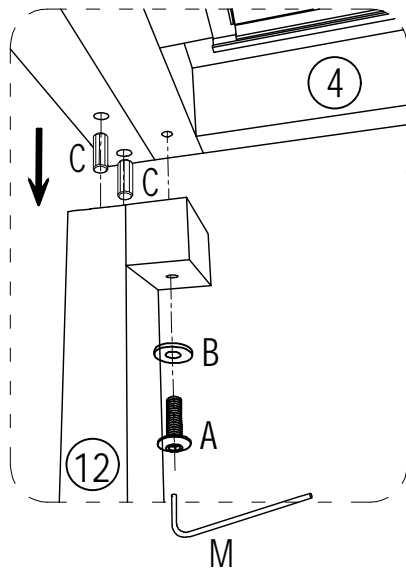

# STEP 16

(A)

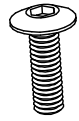

6x30mm  
5 pcs

(B)



6x16mm  
5 pcs

(M)

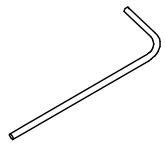

1 pc

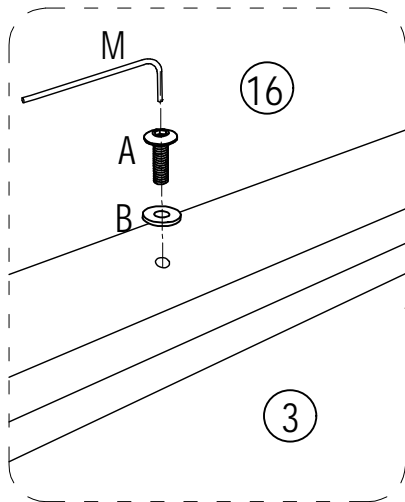
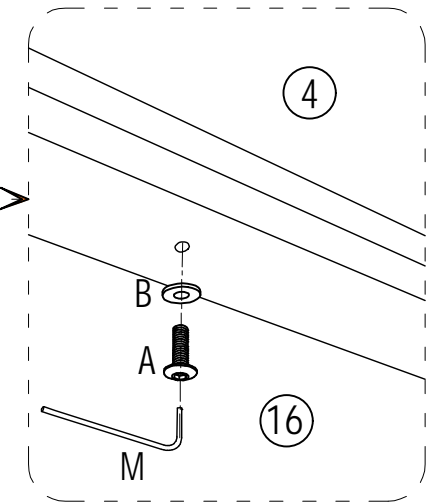
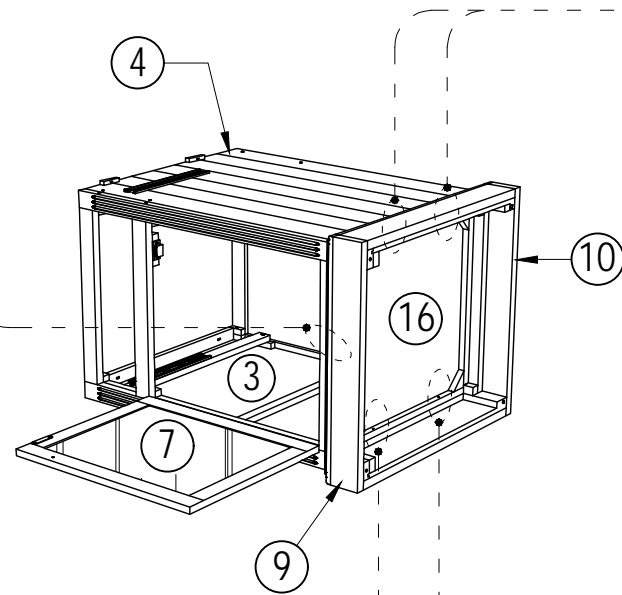
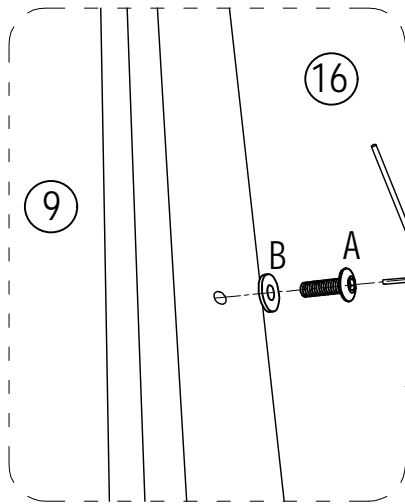

L



4 pcs

# STEP 17

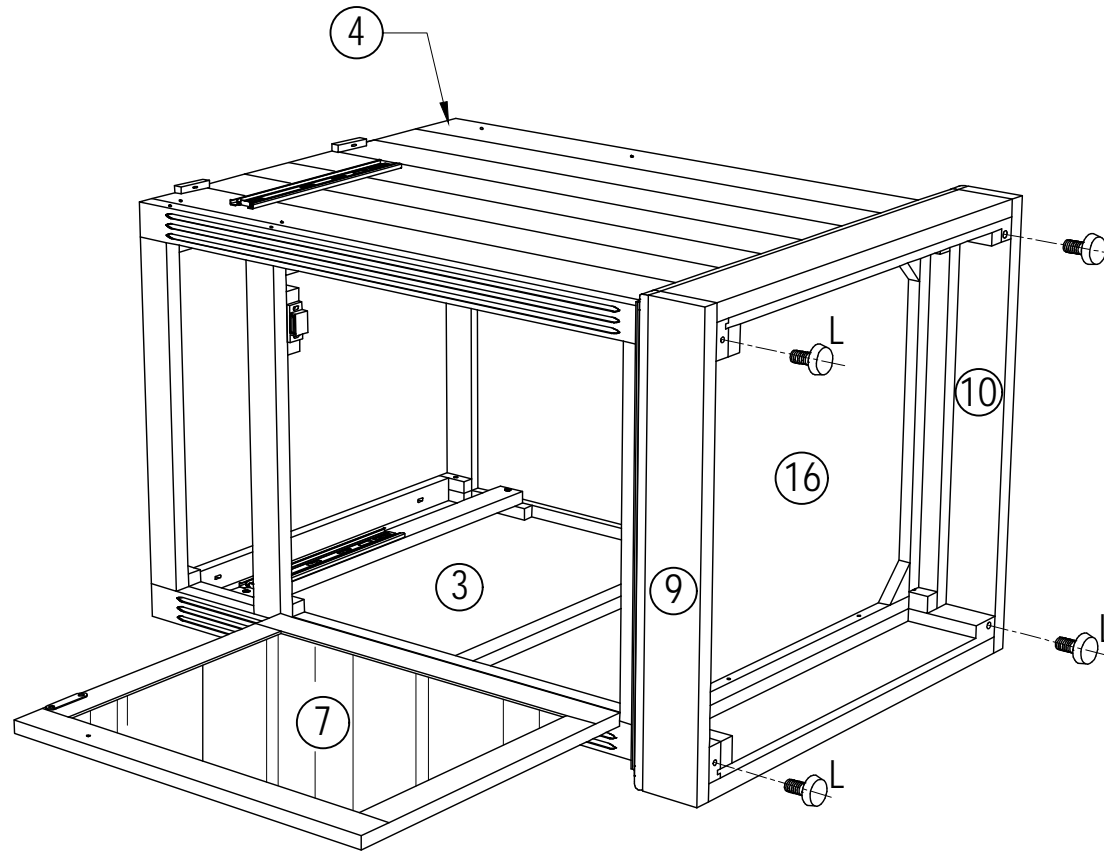

# STEP 18

D



4x25mm  
4 pcs

I

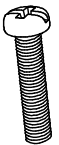

4x25mm  
1 pc

J

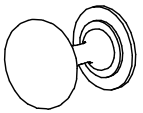

1 pc

N

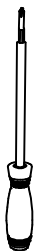

1 pc

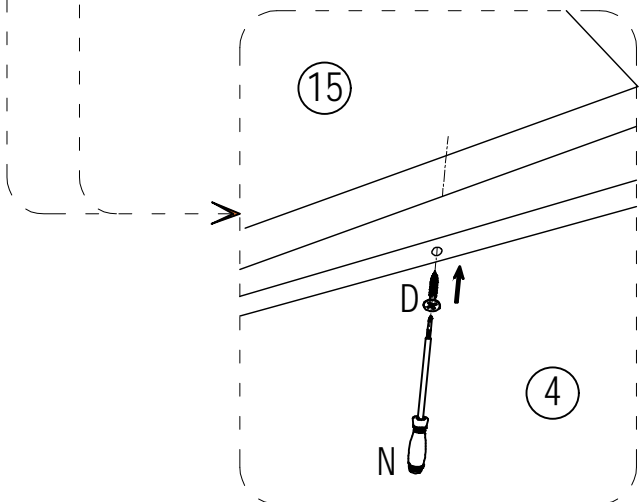
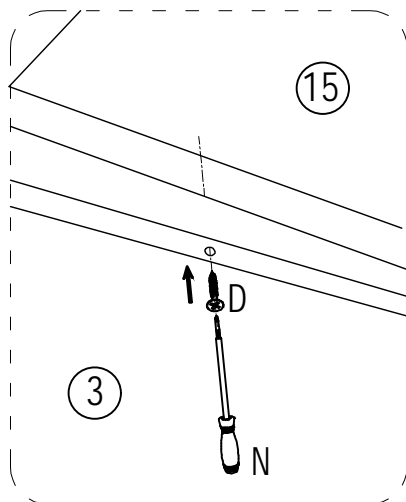
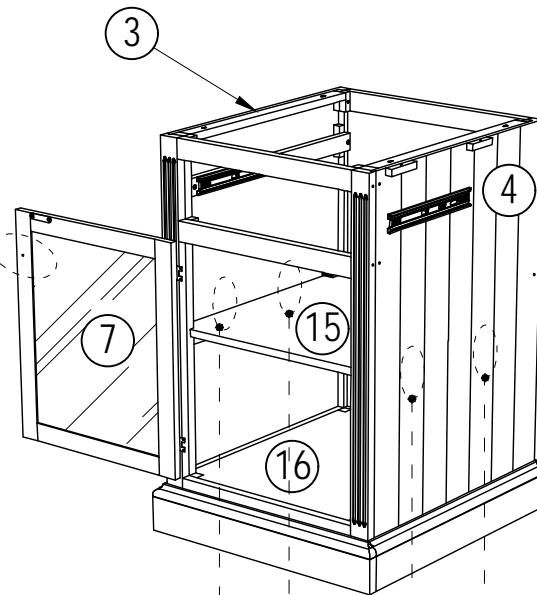
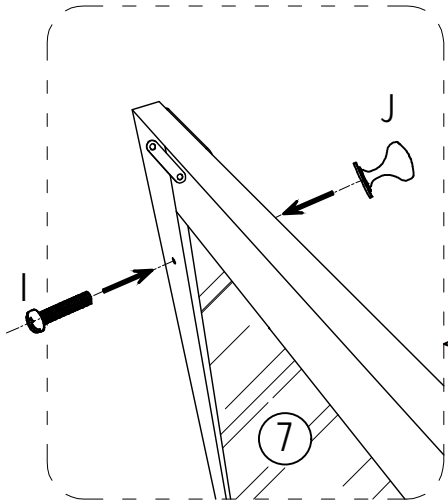

# STEP 19

(A)

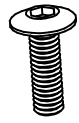

6x30mm  
8 pcs

(B)



6x16mm  
8 pcs

(C)



8x30mm  
4 pcs

(M)

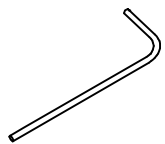

1 pc

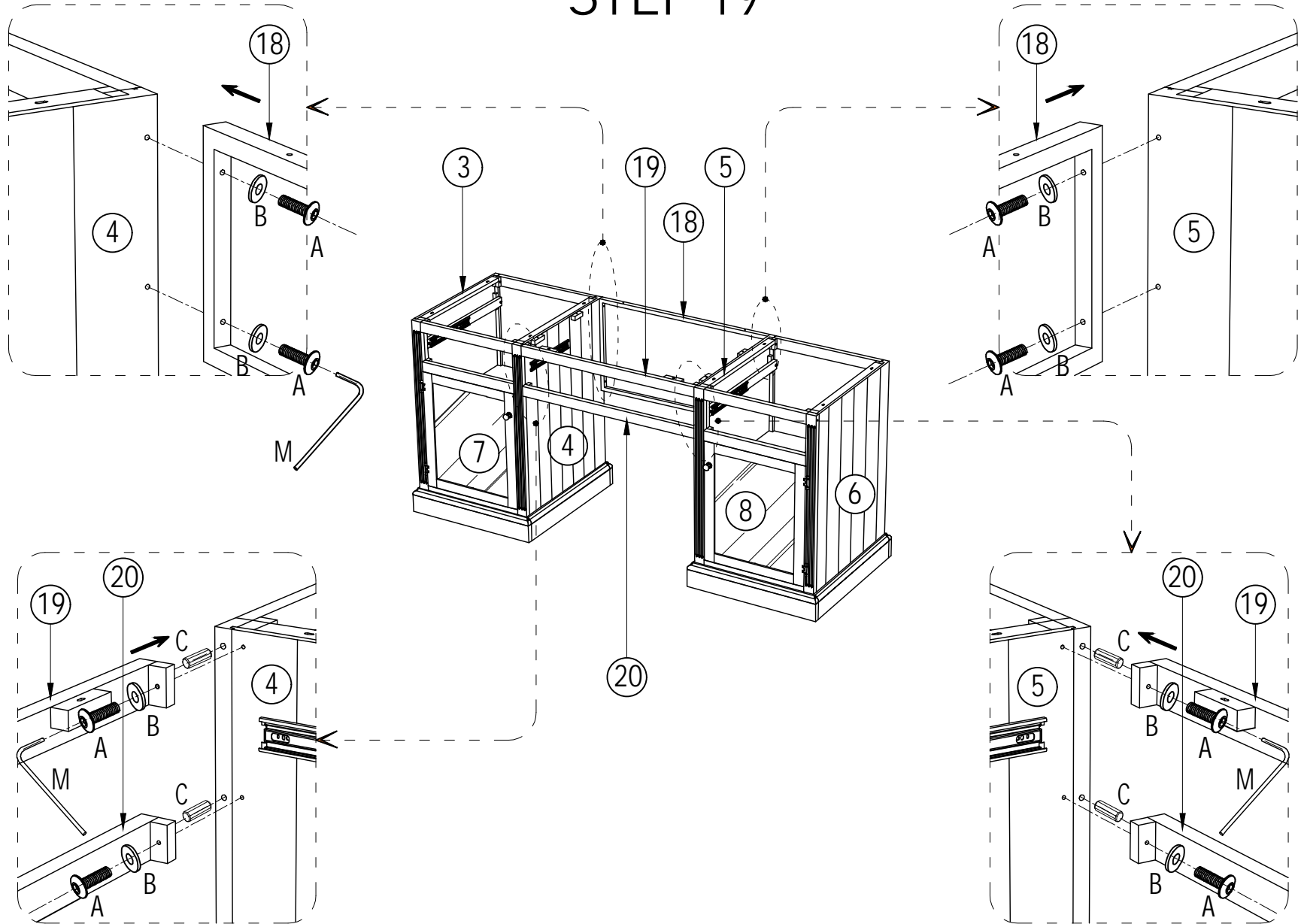

# STEP 20

(A)

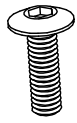

6x30mm  
4 pcs

(B)



6x16mm  
4 pcs

(M)

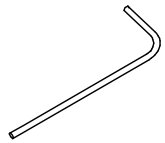

1 pc

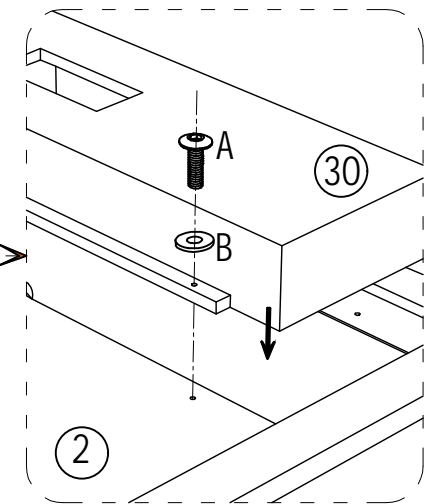
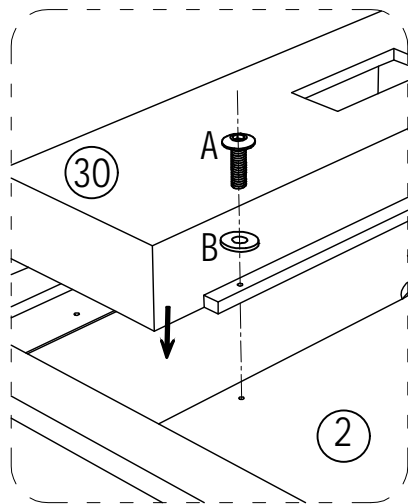
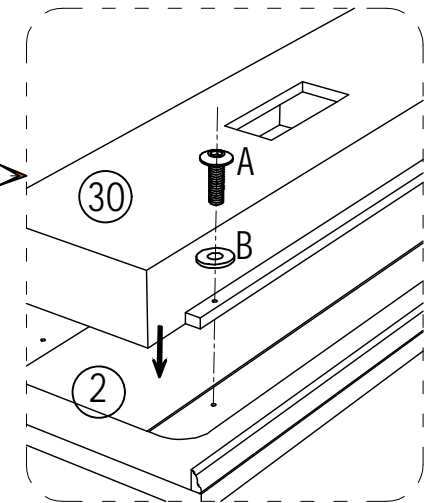
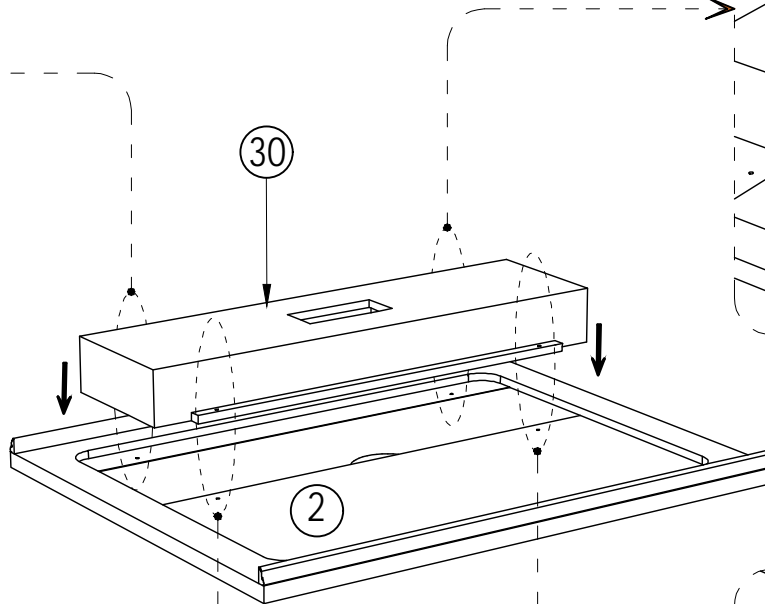
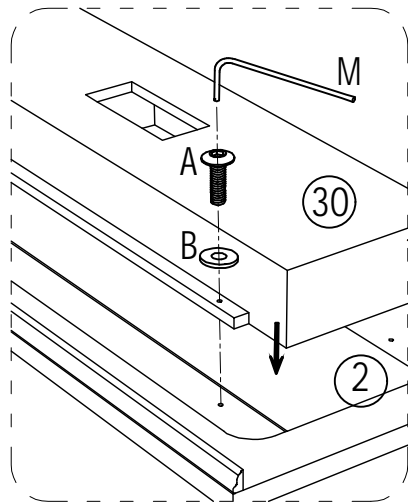

# STEP 21

(A)

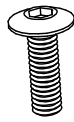

6x30mm  
4 pcs

(B)



6x16mm  
4 pcs

(M)

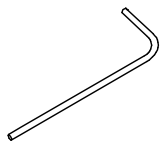

1 pc

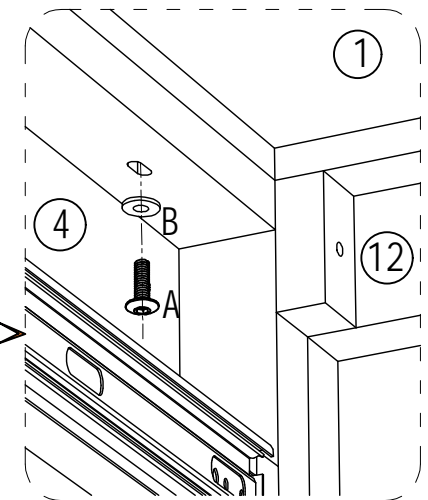
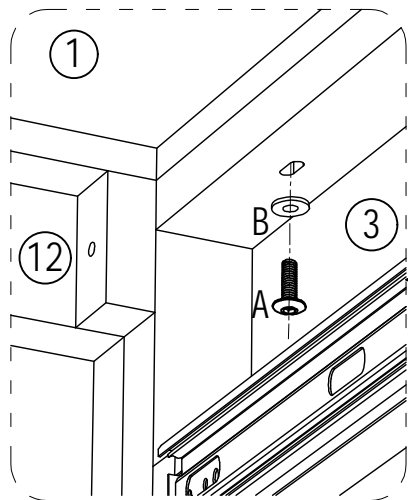
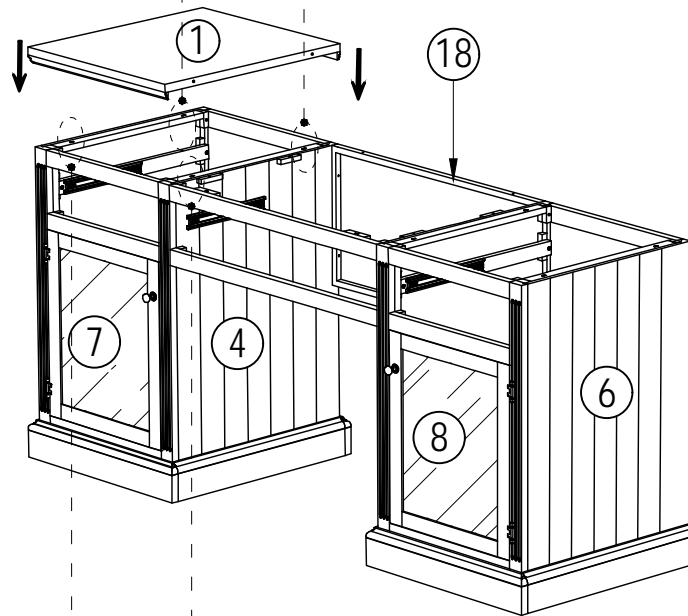
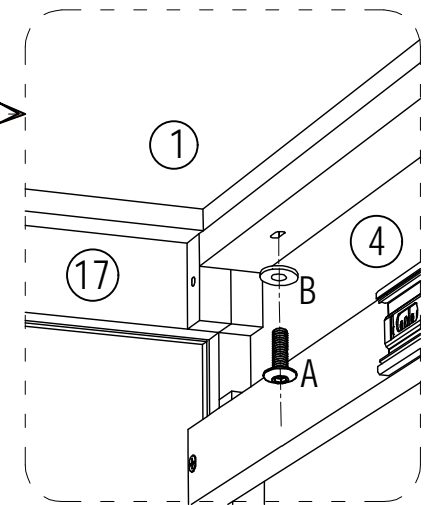
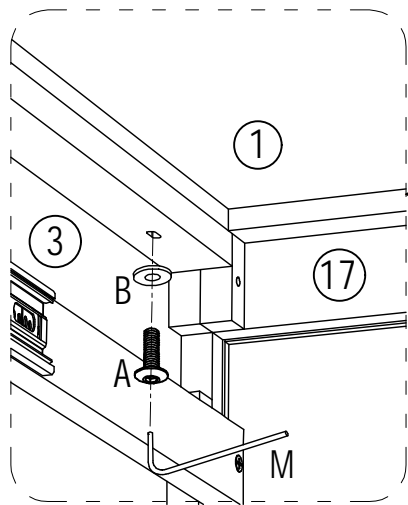

# STEP 22

(A)

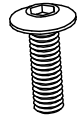

6x30mm  
8 pcs

(B)



6x16mm  
8 pcs

(C)



8x30mm  
2 pcs

(M)

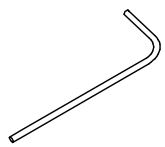

1 pc

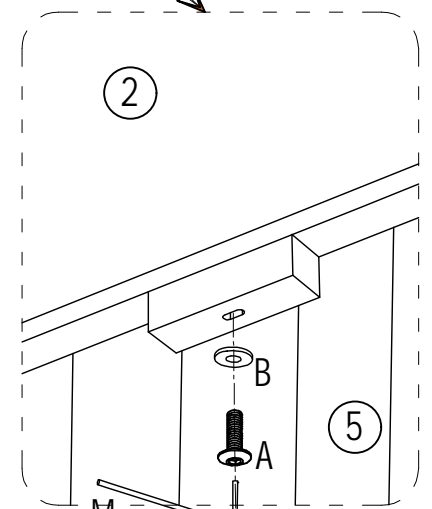
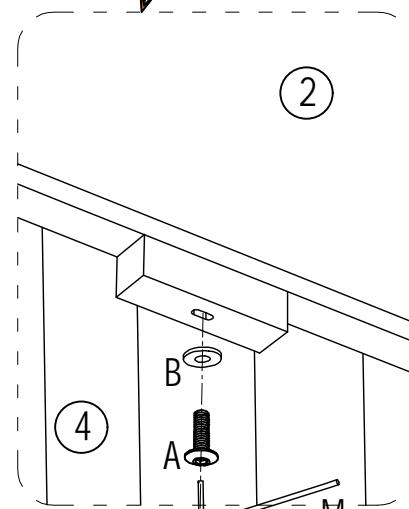
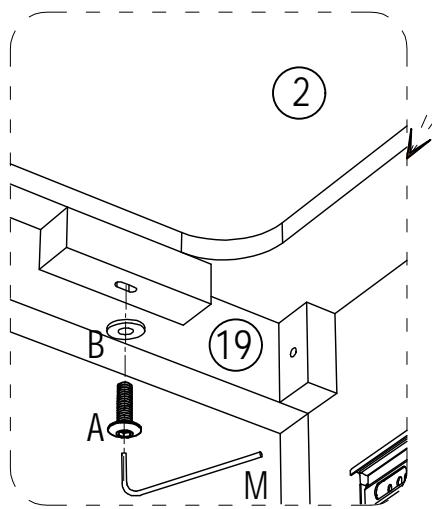
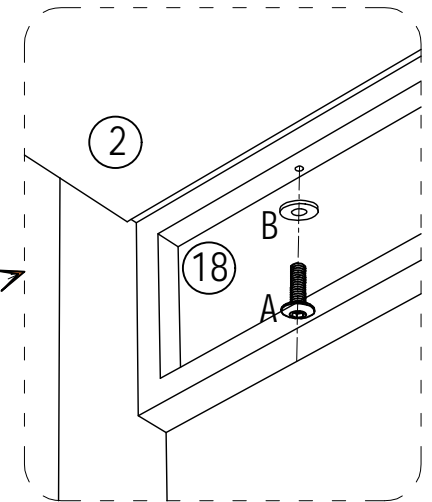
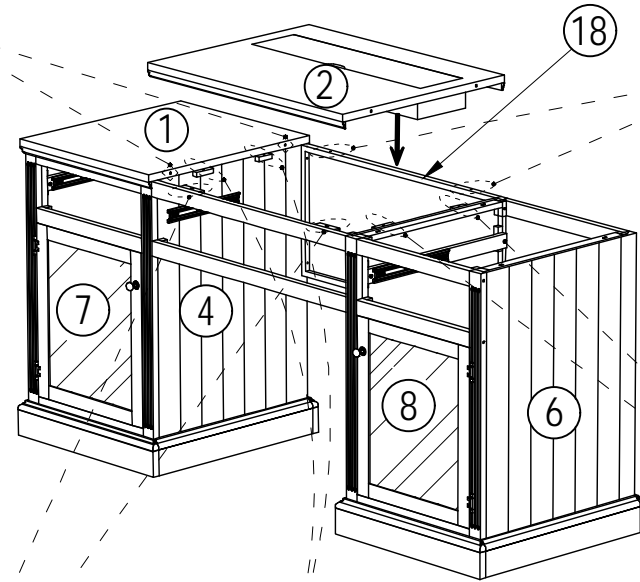
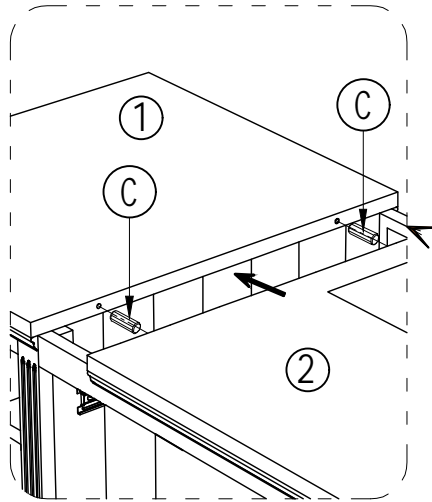

# STEP 23

A

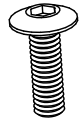

6x30mm  
4 pcs

B



6x16mm  
4 pcs

C



8x30mm  
2 pcs

M

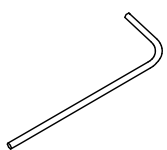

1 pc

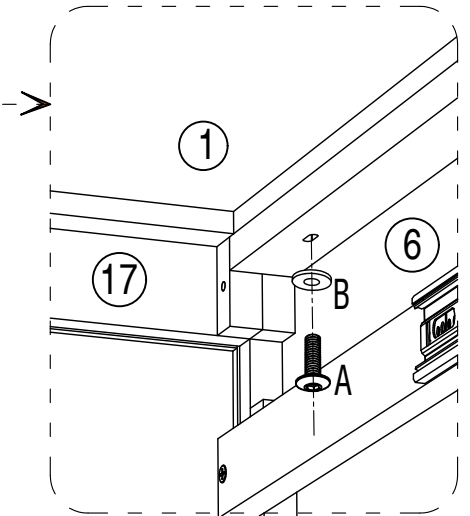
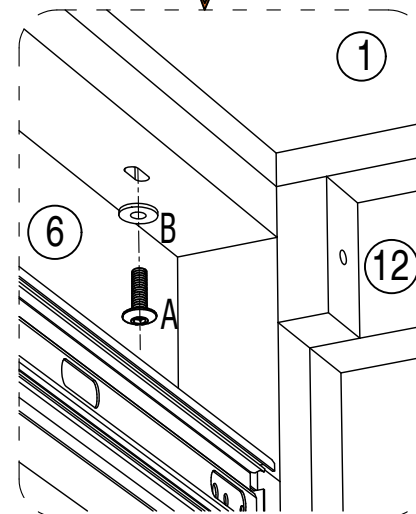
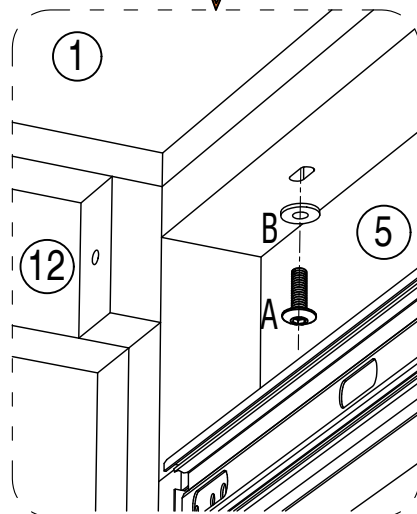
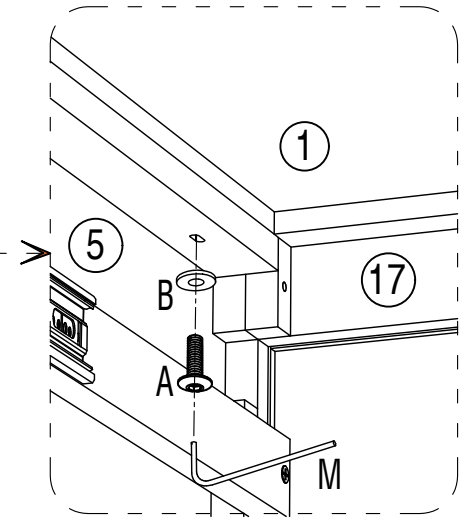
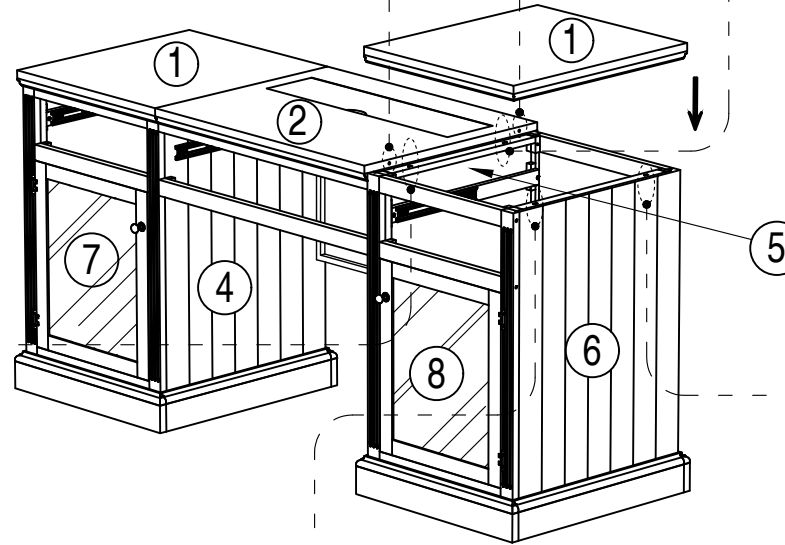
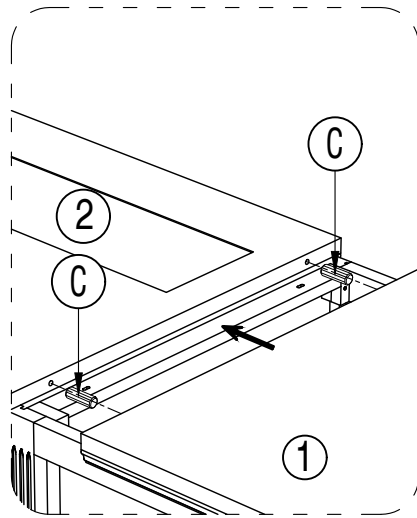

# STEP 24

## Install power outlet

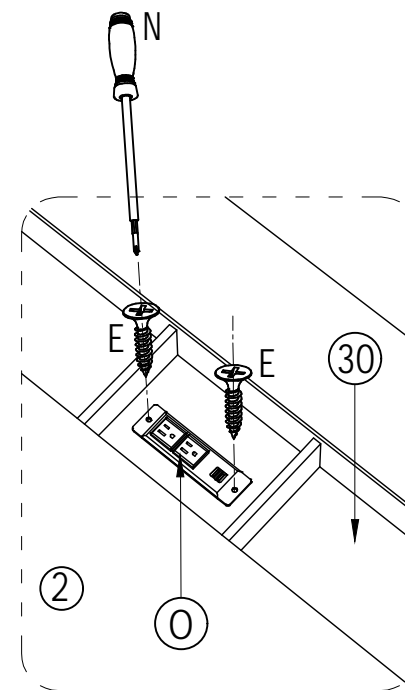
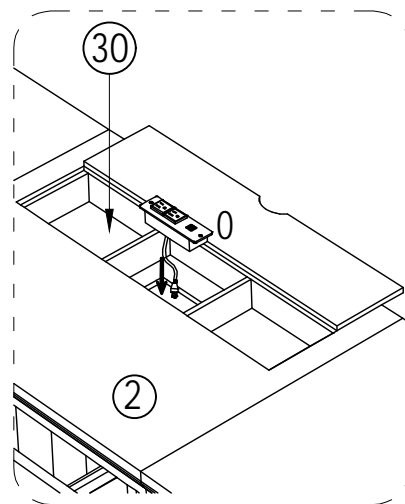
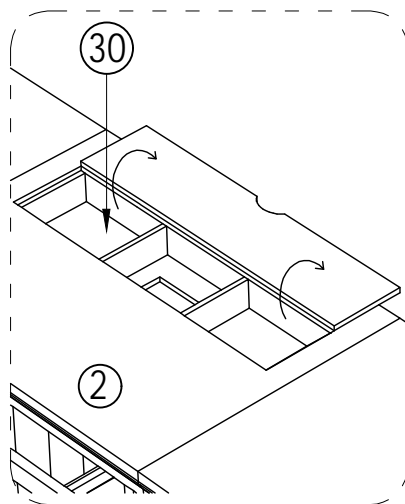

# Typical way to install cam screws

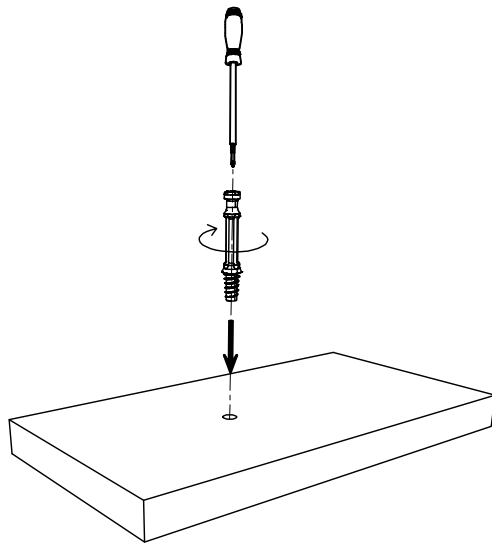

1

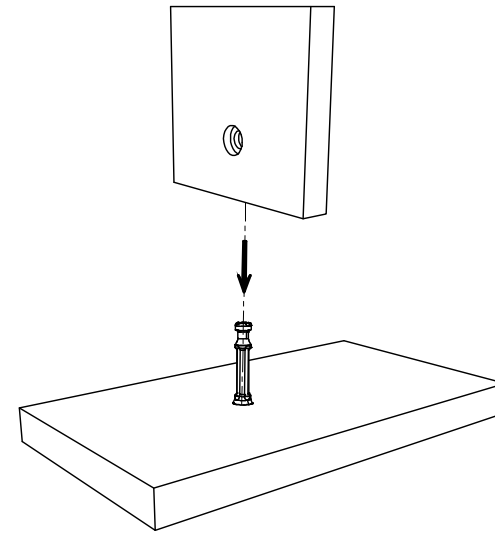

2

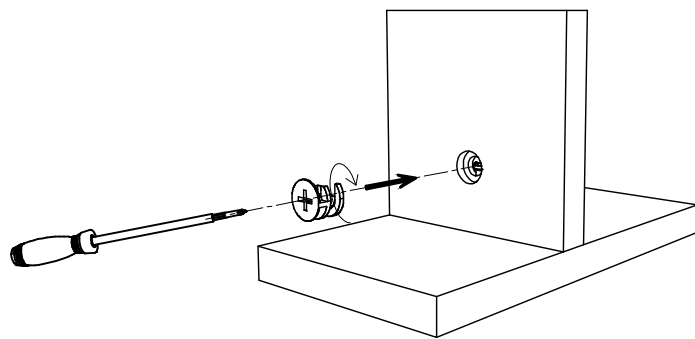

3

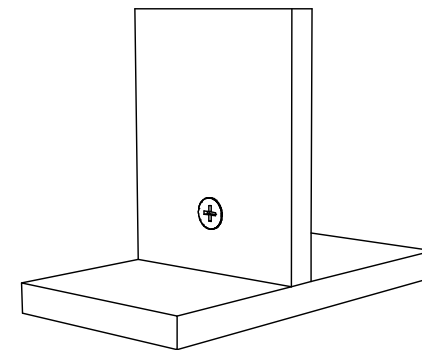

4. Done

# STEP 25

F



3 pcs

G



3 pcs

N

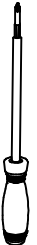

1 pc

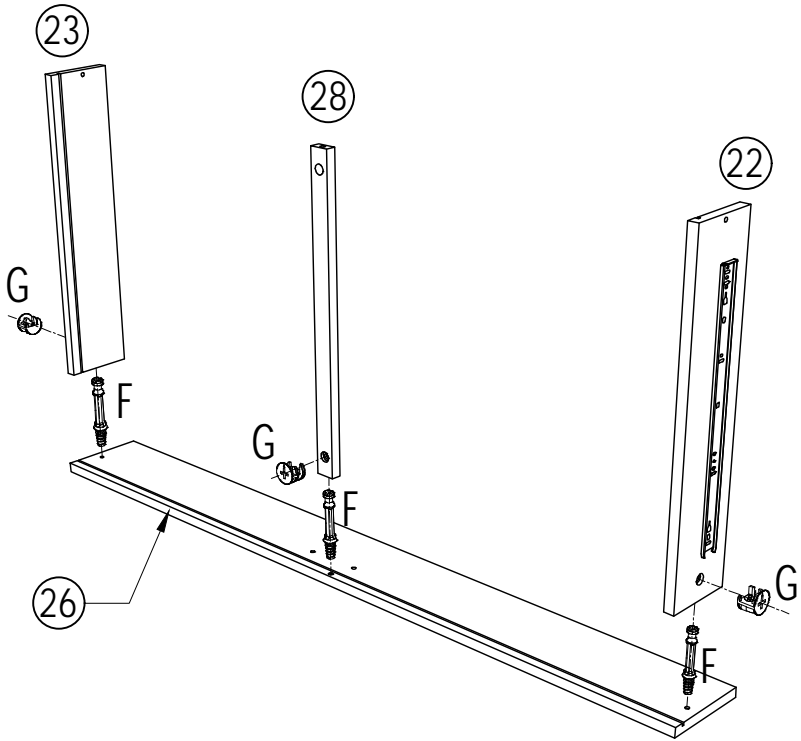

# STEP 26

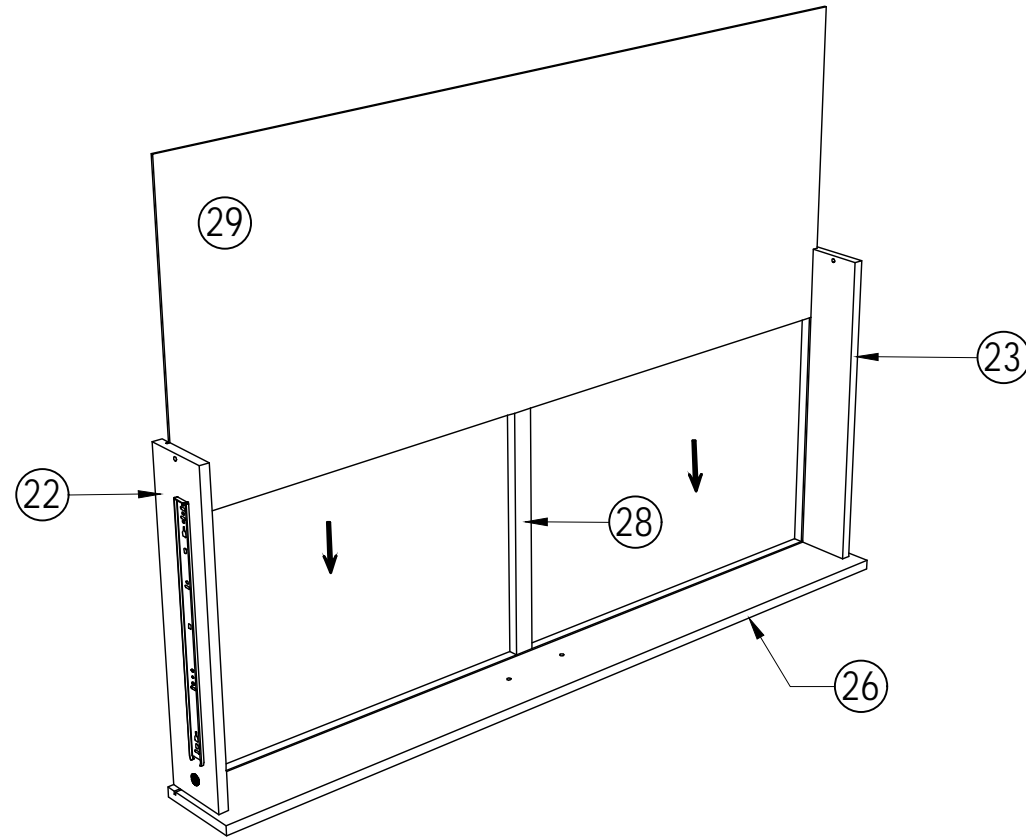

# STEP 27

F



1 pc

G



1 pc

D



4x25mm  
4 pcs

N

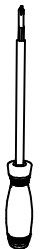

1 pc

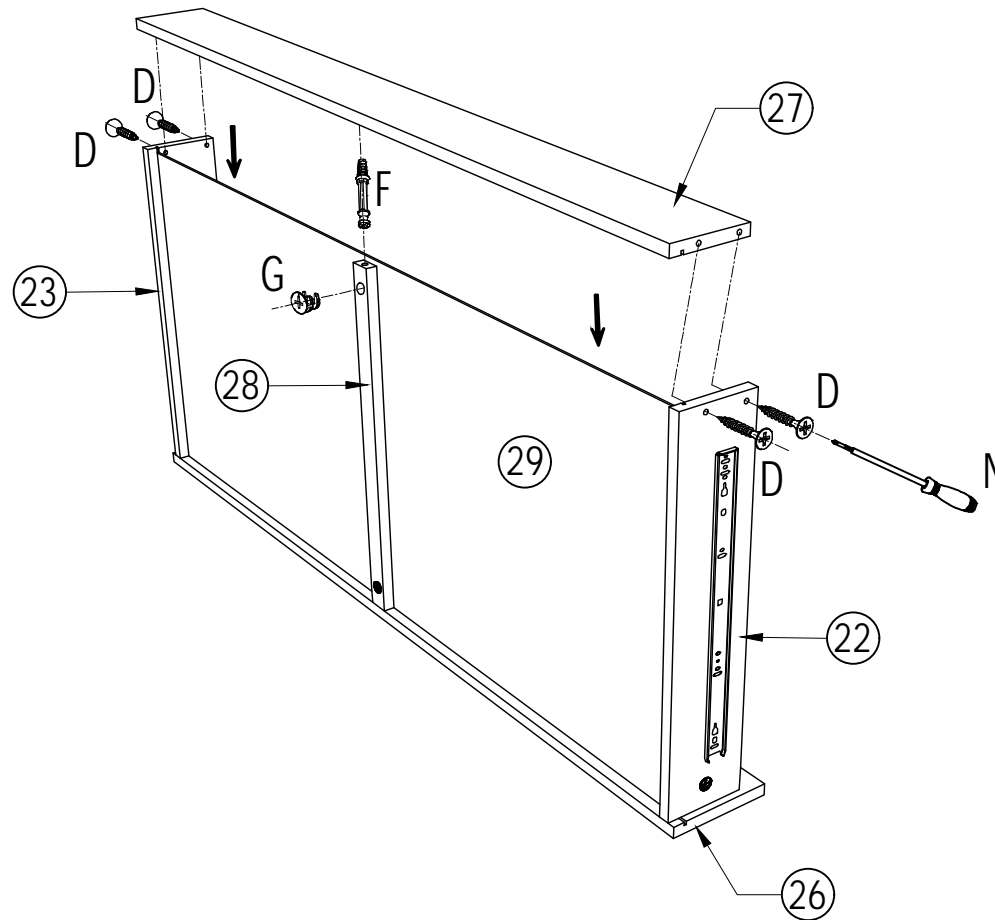

# STEP 28

(H)

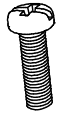

4x15mm  
2 pcs

(K)



Quantity:  
1 pc

(N)

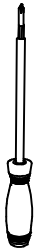

1 pc

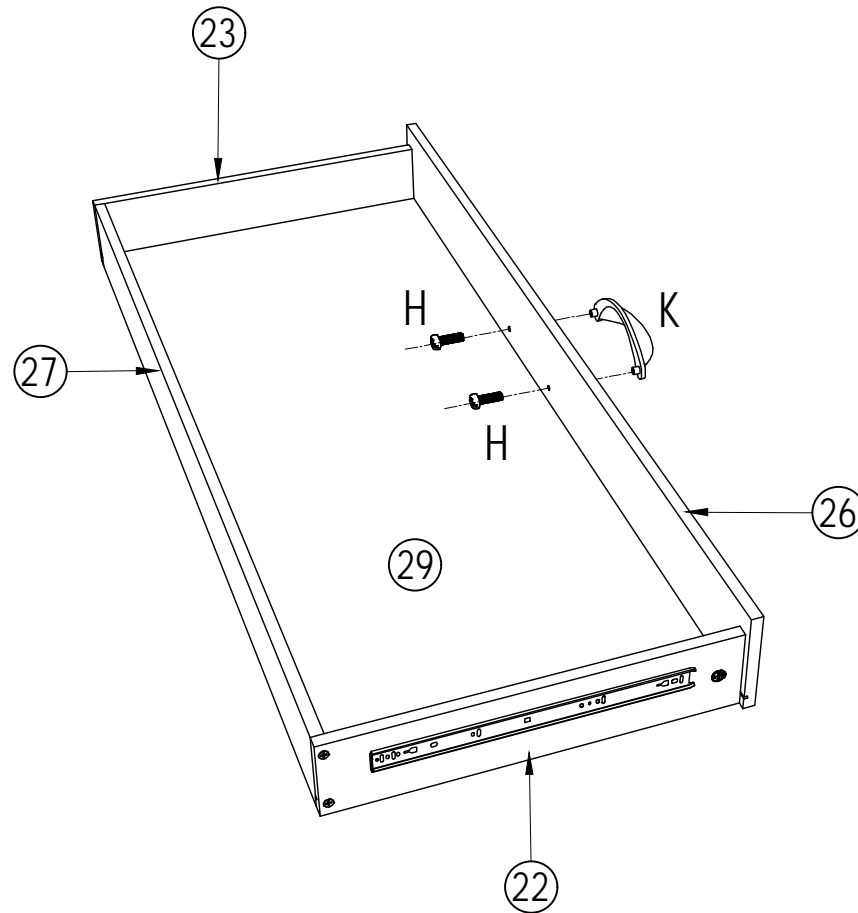

F



4 pcs

G



4 pcs

N

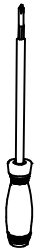

1 pc

# STEP 29 (x2)

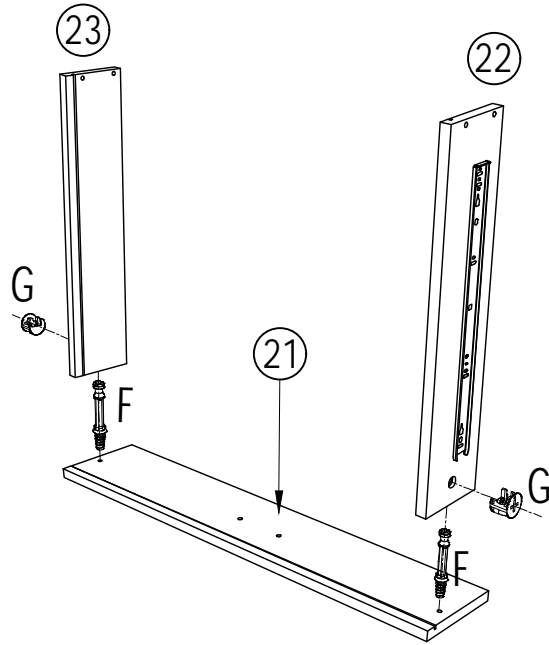

# STEP 30 (x2)

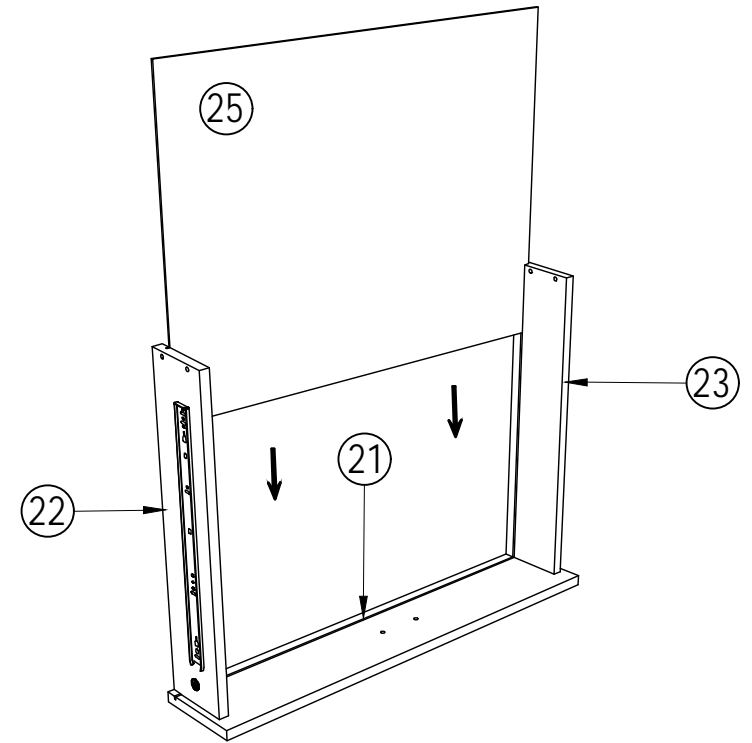



D

4x25mm  
8 pcs

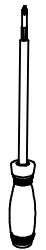

N

1 pc

# STEP 31 (x2)

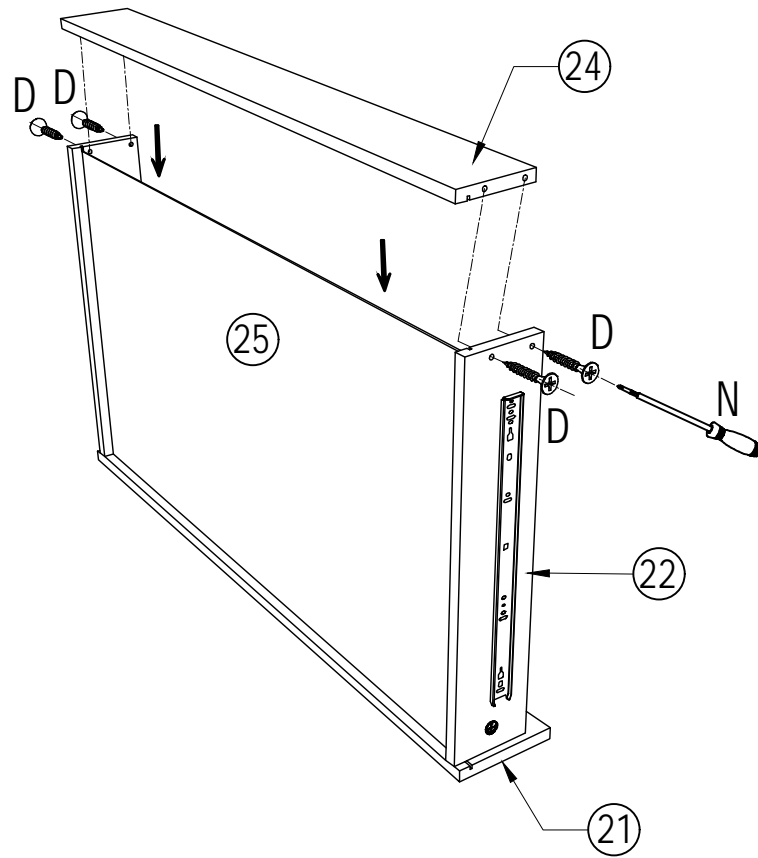

H



4x15mm  
4 pcs

K



2 pcs

N



1 pc

# STEP 32 (x2)

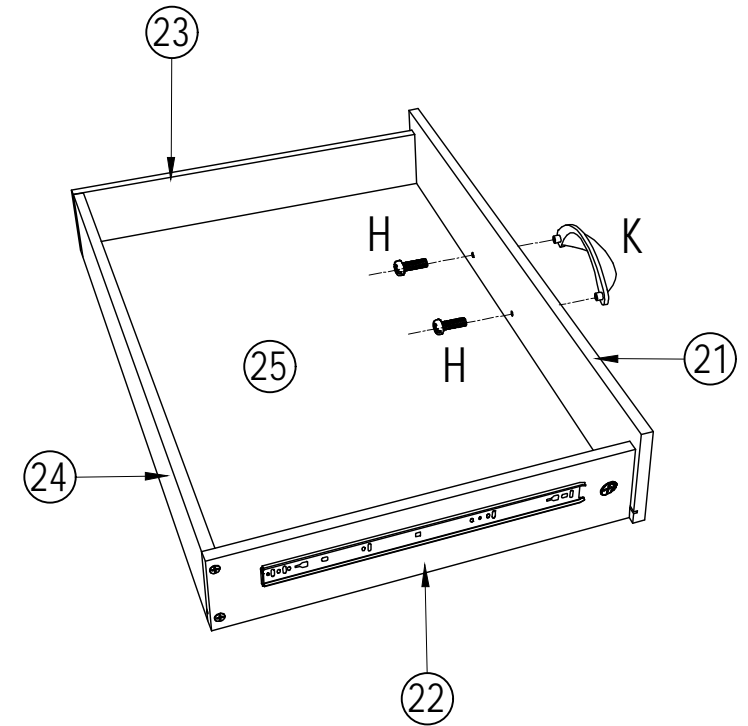

# STEP 33

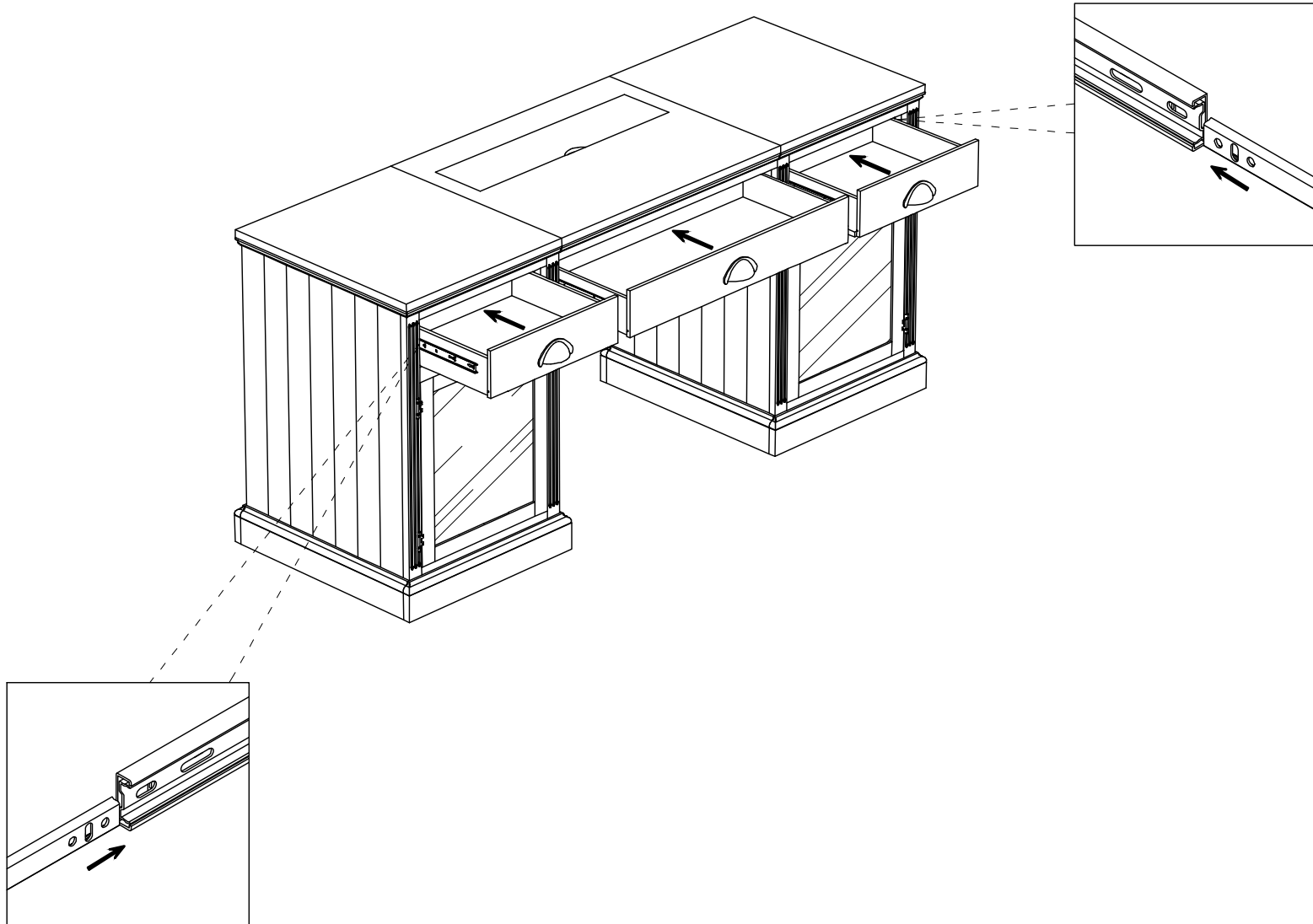

# FINISH

