

Assembly Instructions

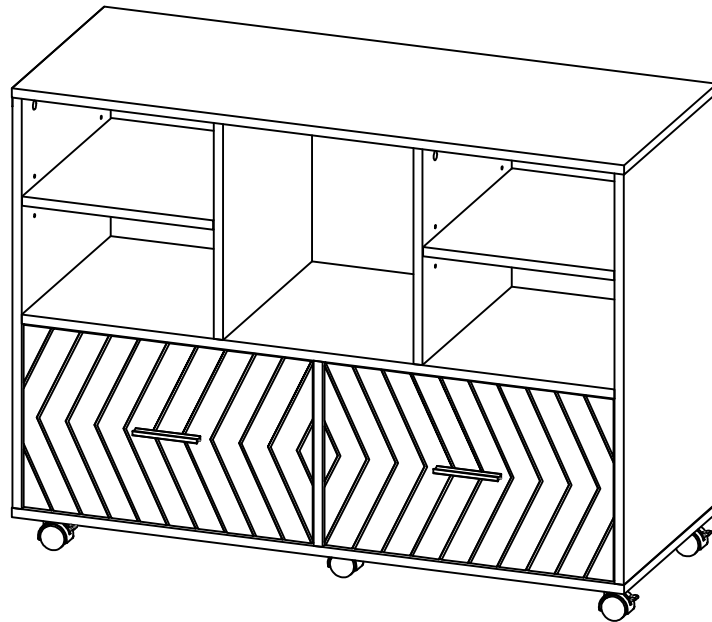

File Cabinet

Assembly Instructions:

1. Carefully read these instructions and keep them for future reference.
 2. Refer to the parts list for guidance and ensure that you have all the pieces before starting the assembly process, if anything is missing, damaged, incorrect, contact us **FIRSTLY BEFORE** assembling.
 3. When assembling, place all parts on a soft, clean, and flat surface, such as a carpet, to prevent any scratches.
 4. To avoid misalignment of the holes, Please don't full tighten the screws until you ensure all parts in place.
-

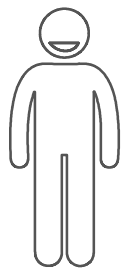

X2

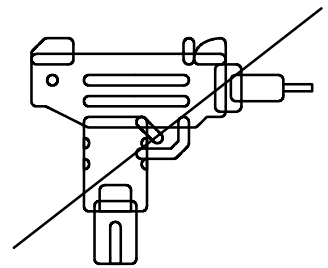
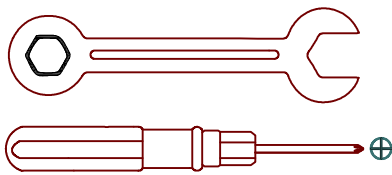

When using the electric screwdriver ,
Reduce the power and torque to avoid damaging the furniture

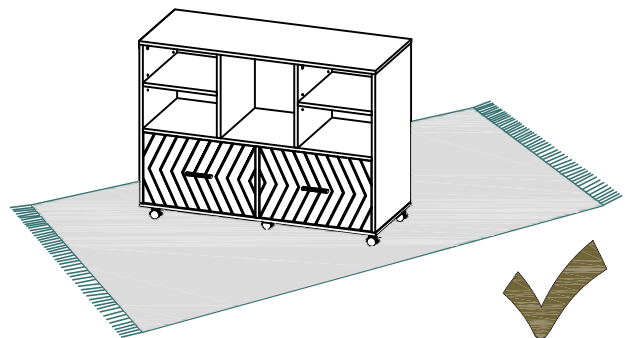
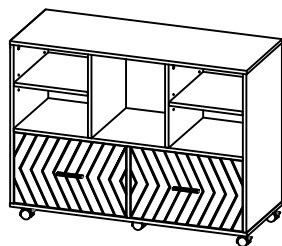
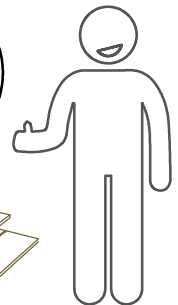
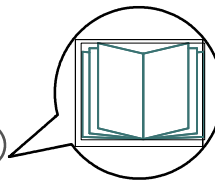
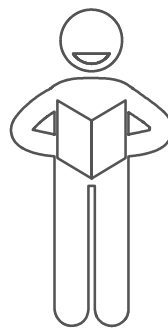
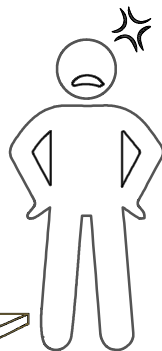
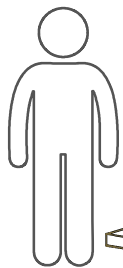

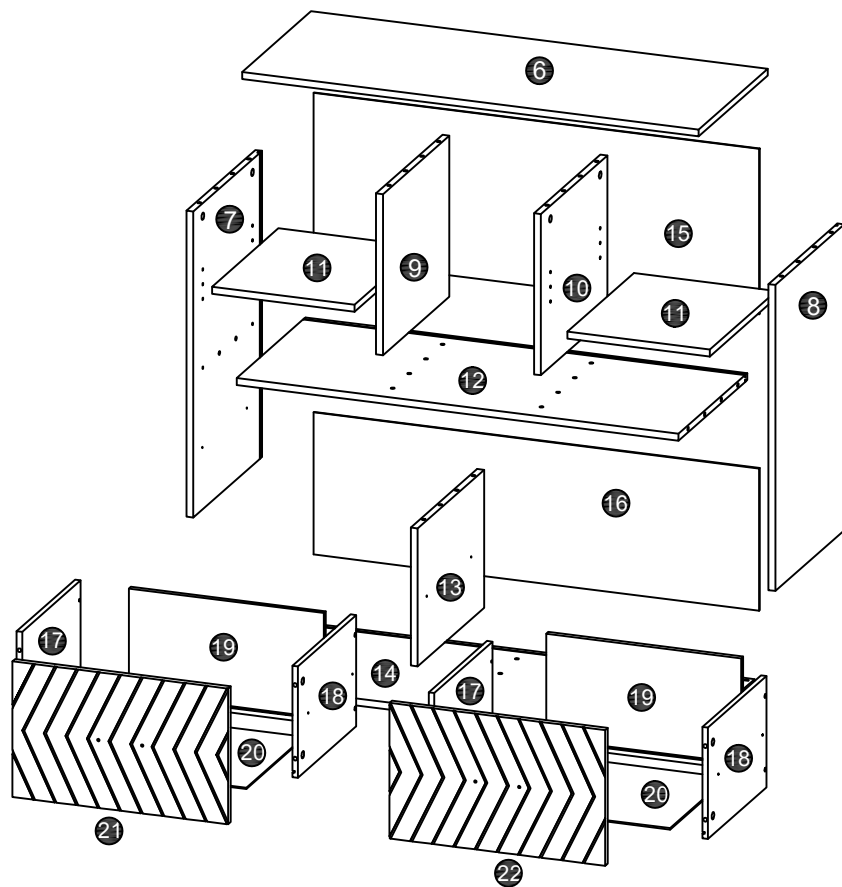

⚠ Caution

Make sure all parts are included. Most board parts are labeled or stamped on the raw edge. contact us for free replacement if having damaged or missing parts.

Parts & Hardware List

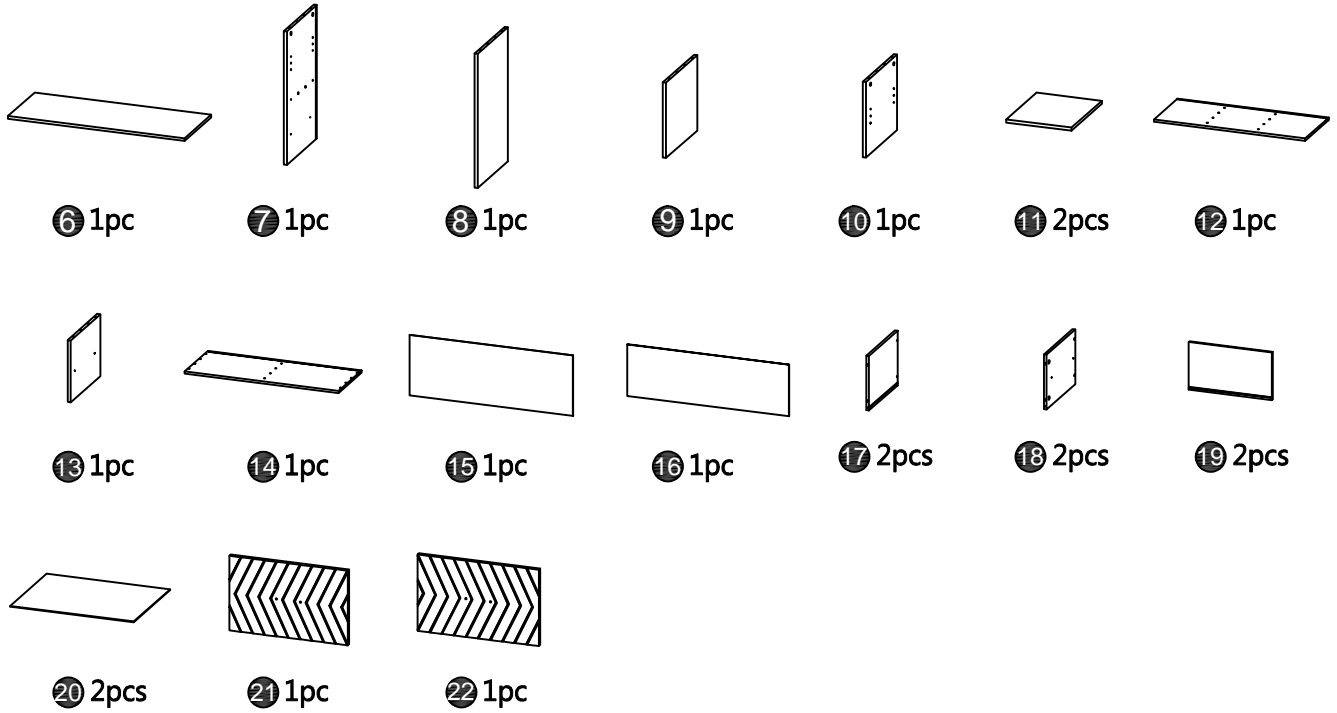

Hardware List

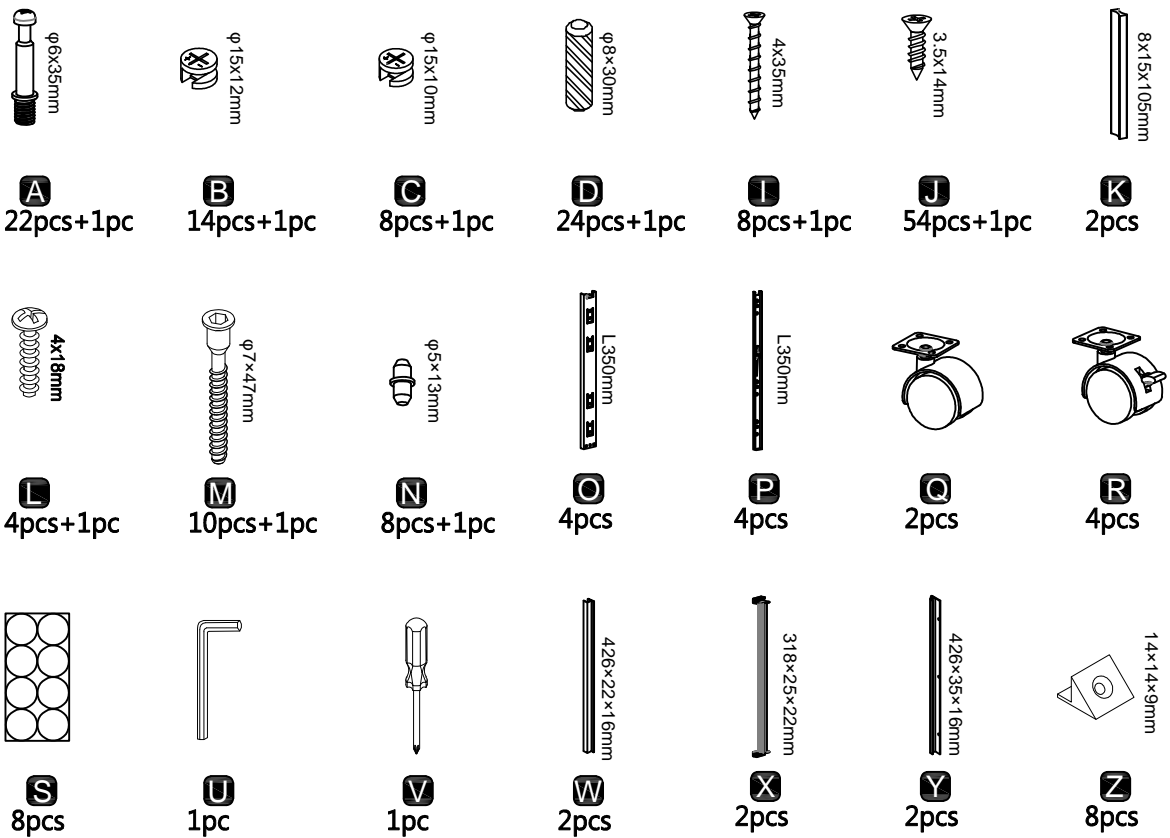

Installation of Cams and Pins

Screw the pin into the hole. To set the cams correctly, ensure that the arrow on the cam is opening to the hole of the pin it is locking. Lock the cam by turning the cam head with a screwdriver until it is tightened. Please do not use an electric screwdriver to assemble the unit.

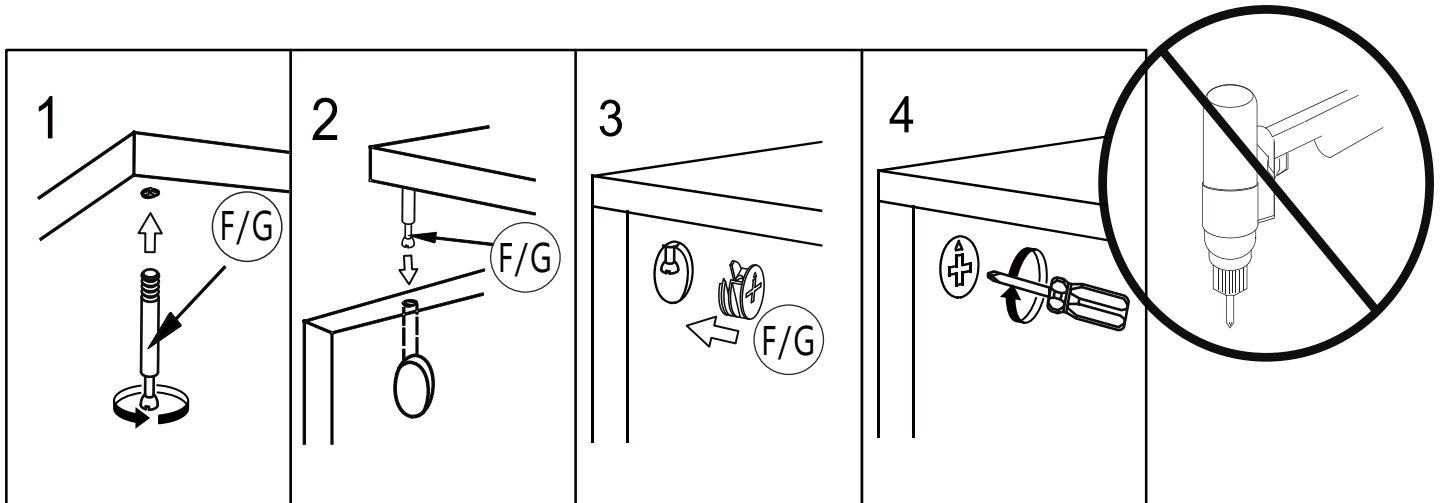

Read each step carefully before starting. It is very important that each step of instruction is performed in the correct order. If these steps are not followed in sequence, assembly difficulties will occur.

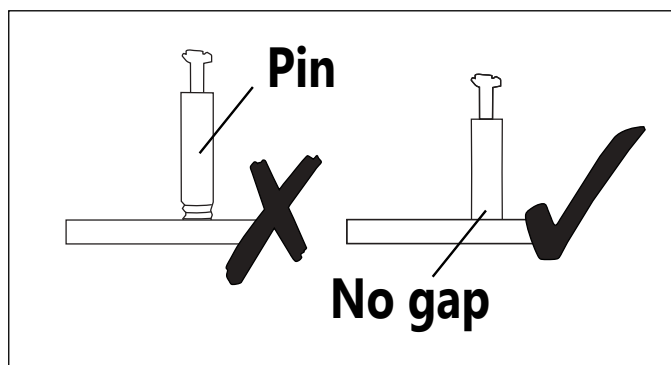

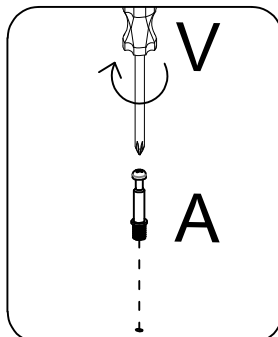
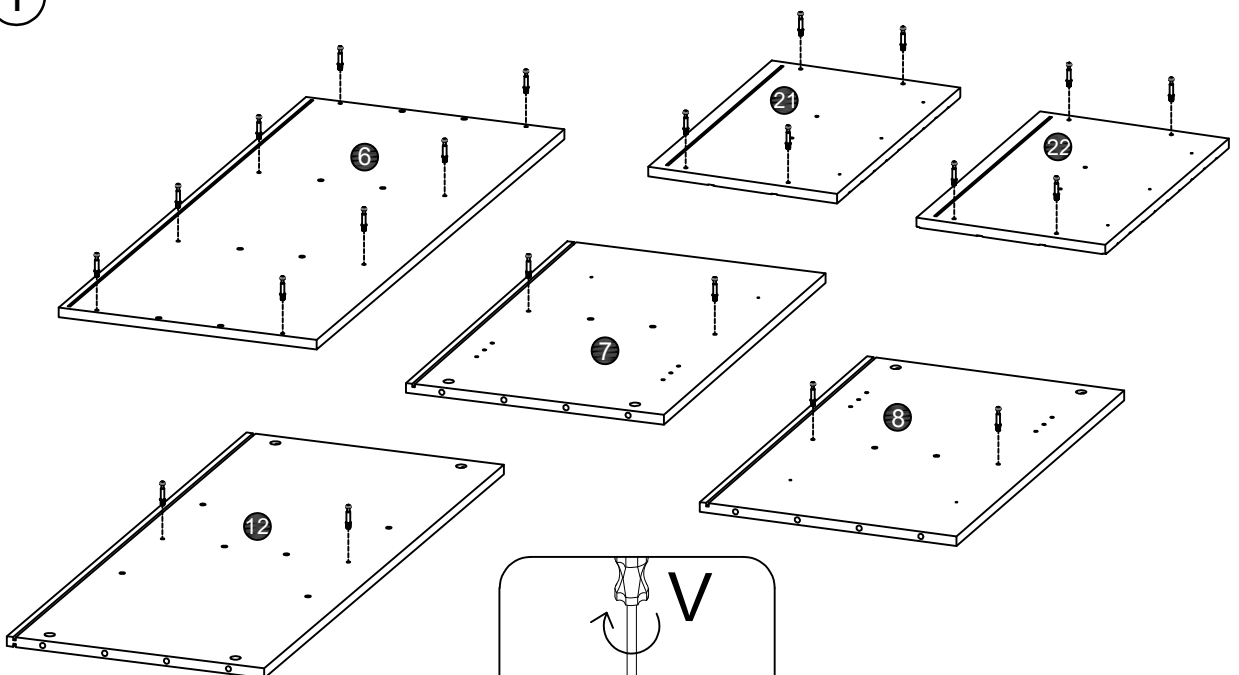

1

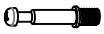

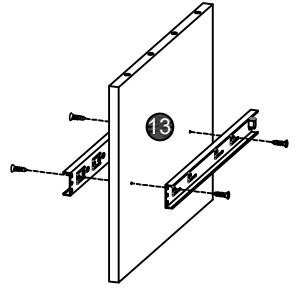
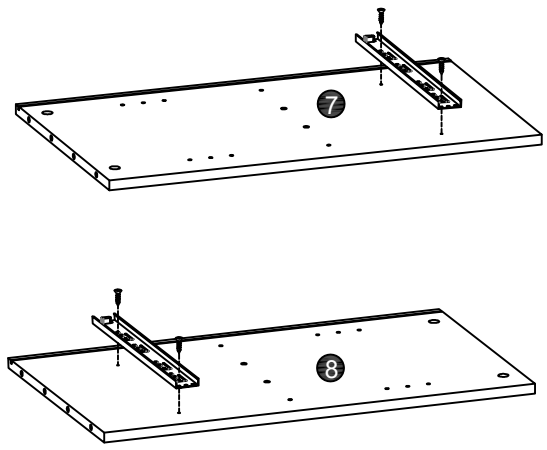
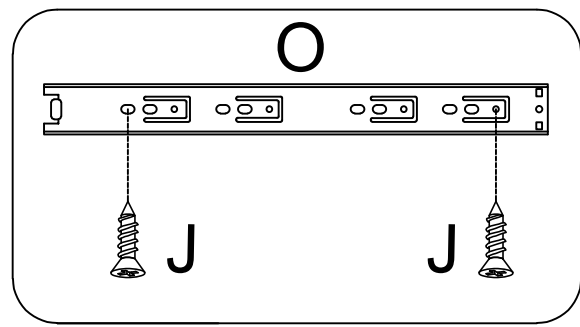
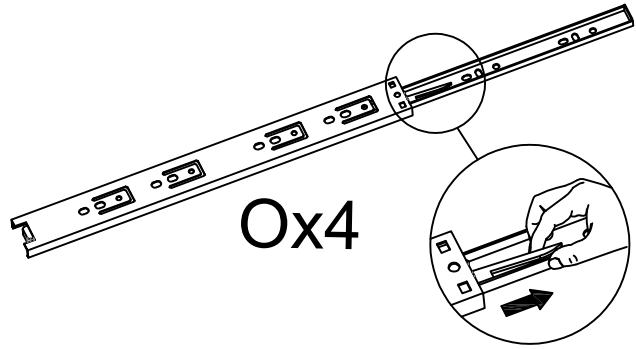

φ6x35mm
Ⓐ ×22pcs

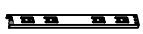

2

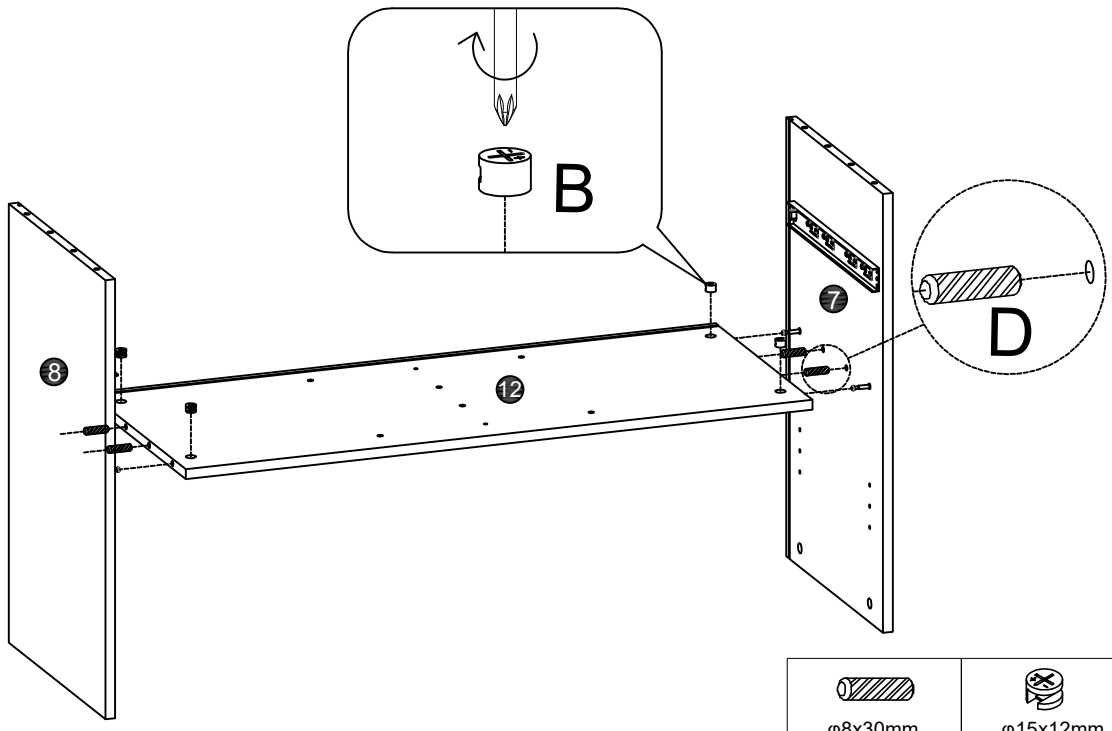

	
L350mm	3.5x14mm
ⓐ ×4pcs	ⓙ ×8pcs



3

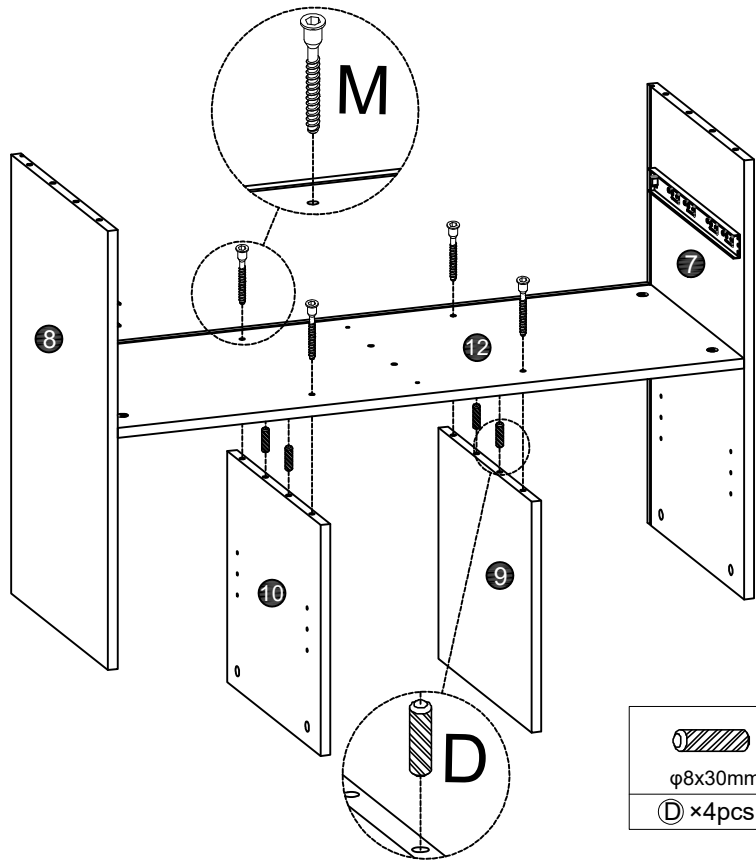

	
φ8x30mm	φ15x12mm
ⓓ ×4pcs	ⓑ ×4pcs

4



	
φ8x30mm	φ7x47mm
ⓓ ×4pcs	Ⓜ ×4pcs

5

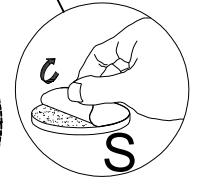
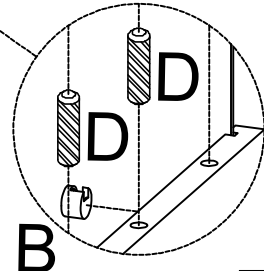
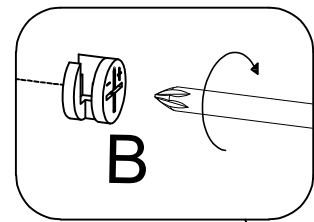
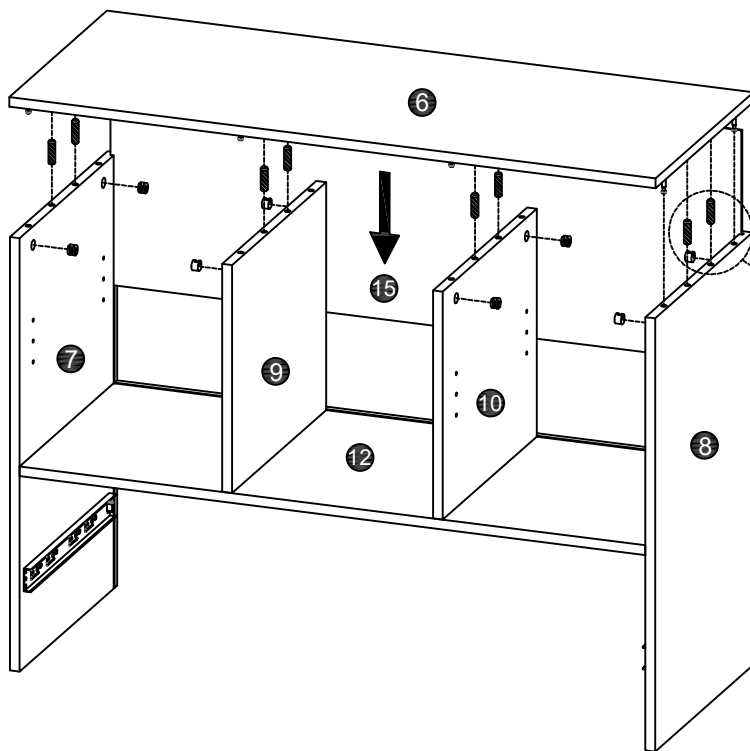

 S × 8 pcs	
 φ8x30mm	 φ15x12mm
D × 8 pcs	B × 8 pcs

6

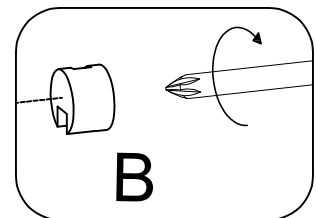
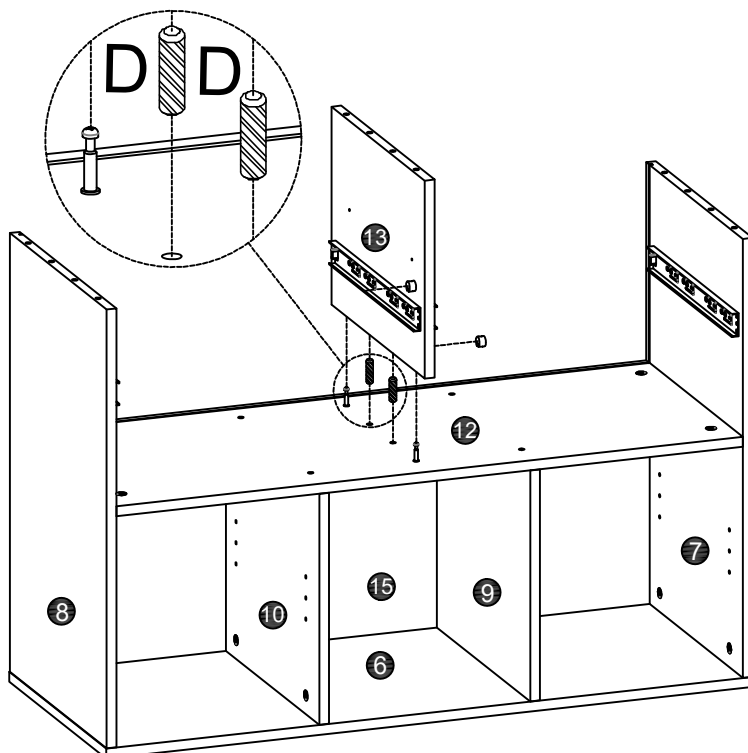

 φ8x30mm	 φ15x12mm
D × 2 pcs	B × 2 pcs

7

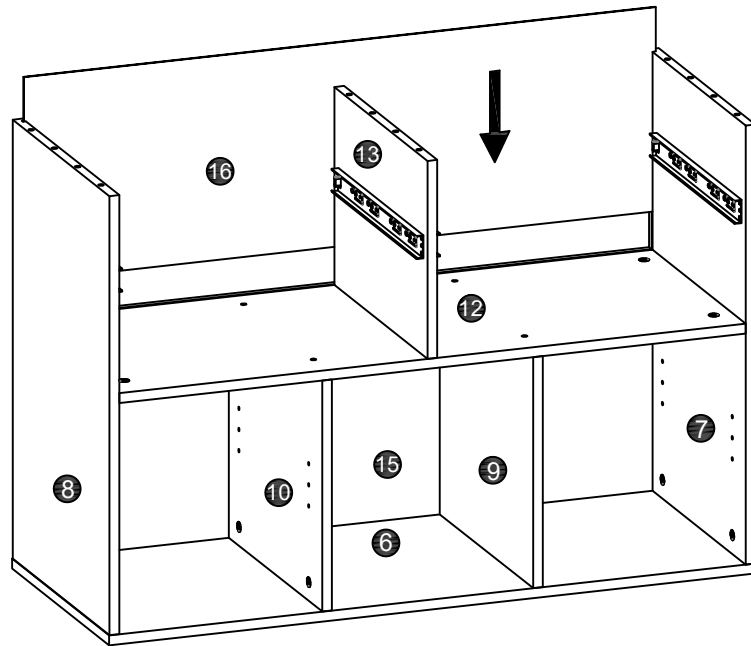

8

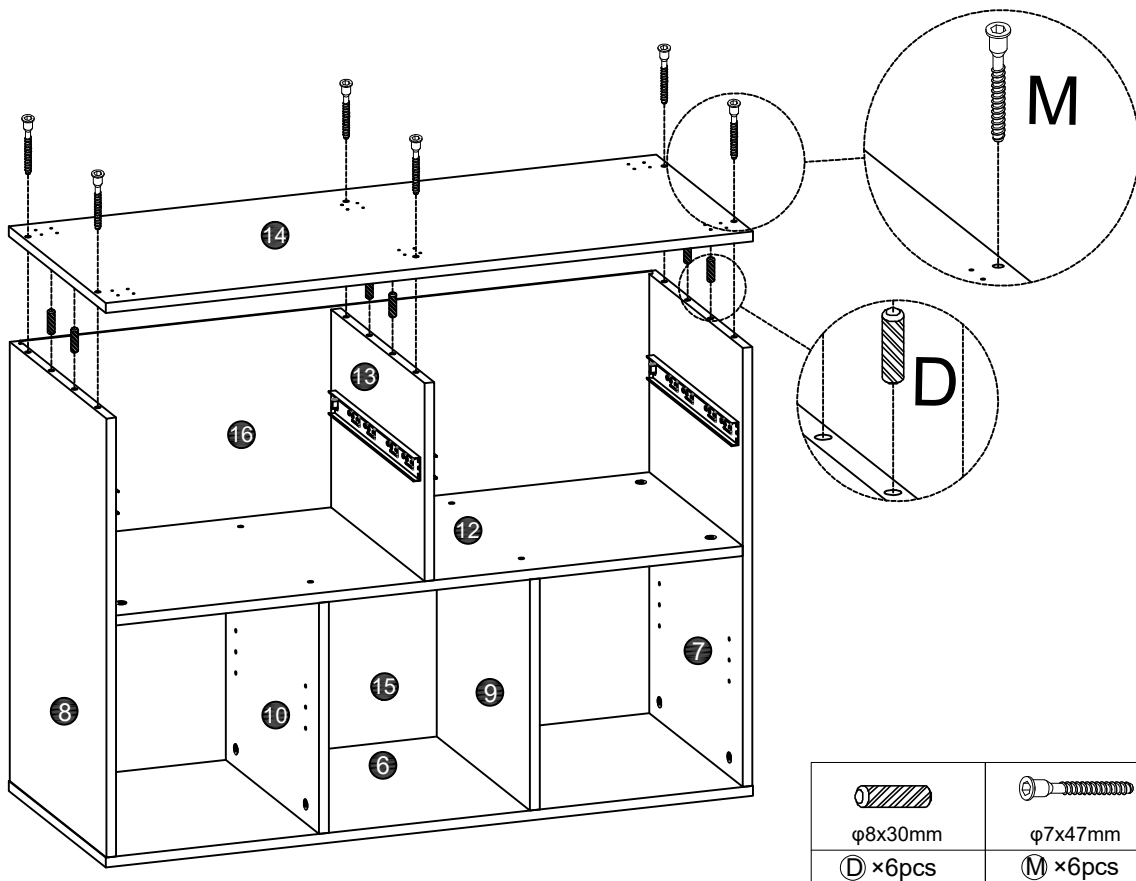

9

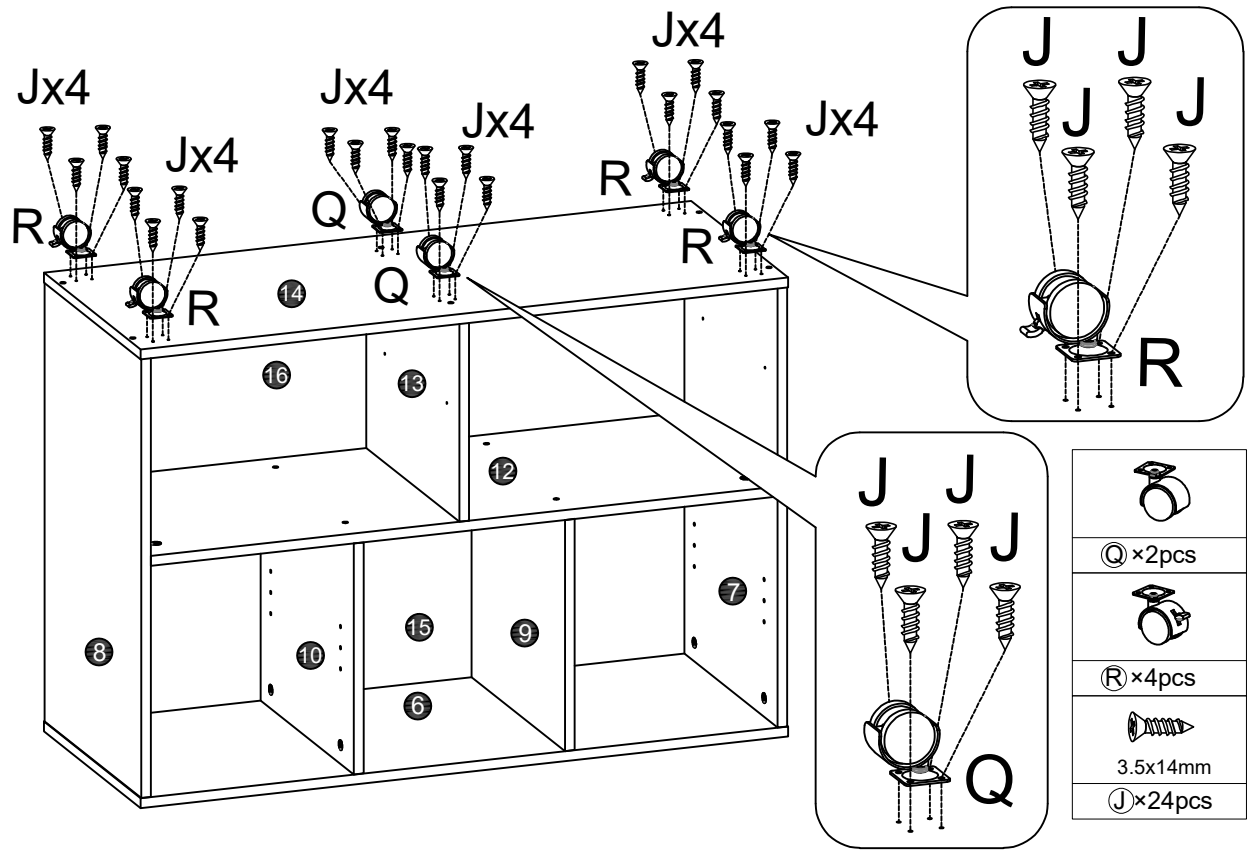

10

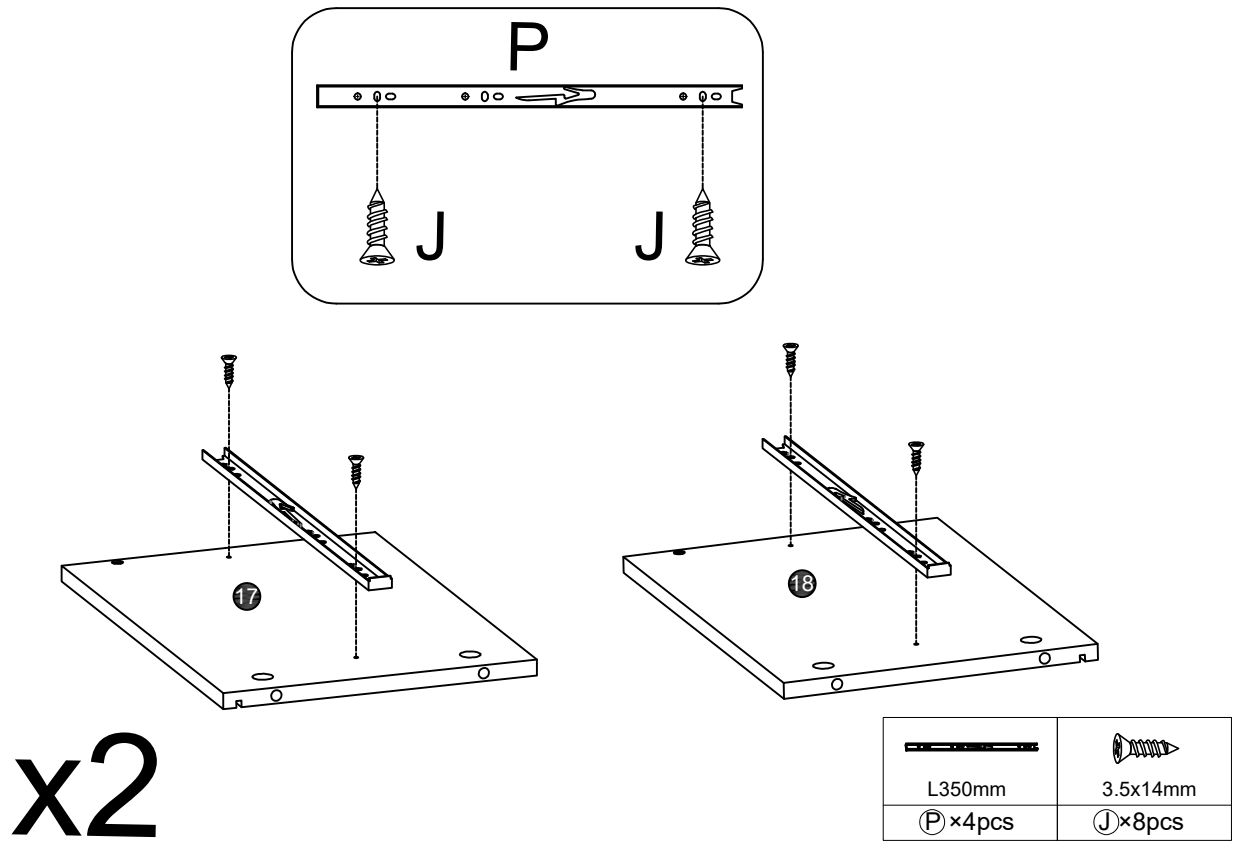

11

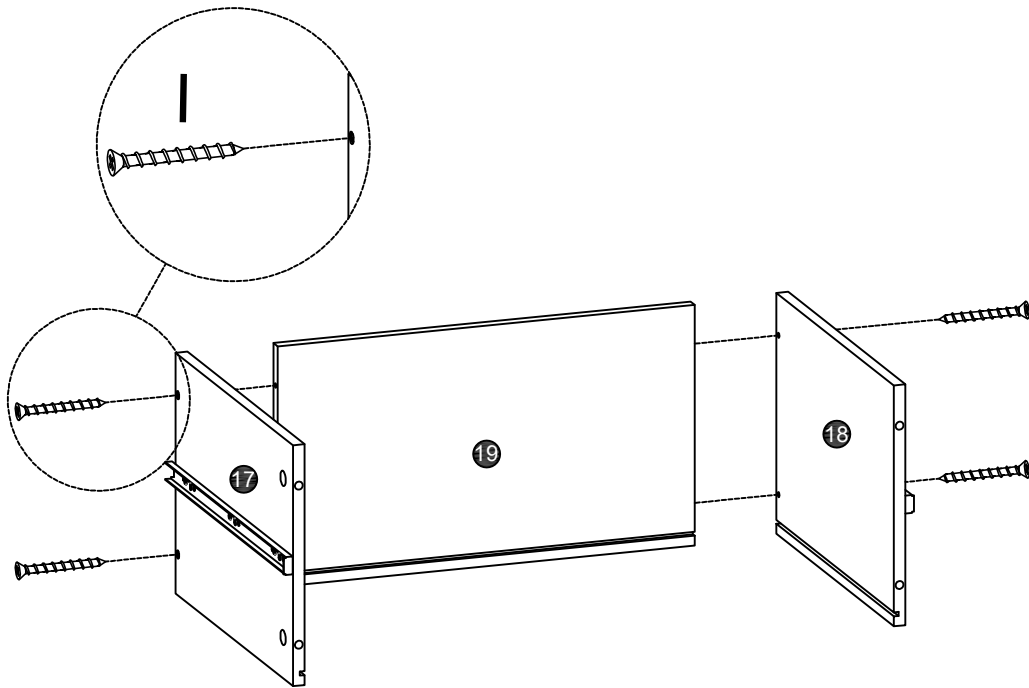

x2

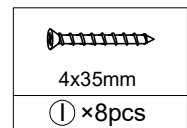

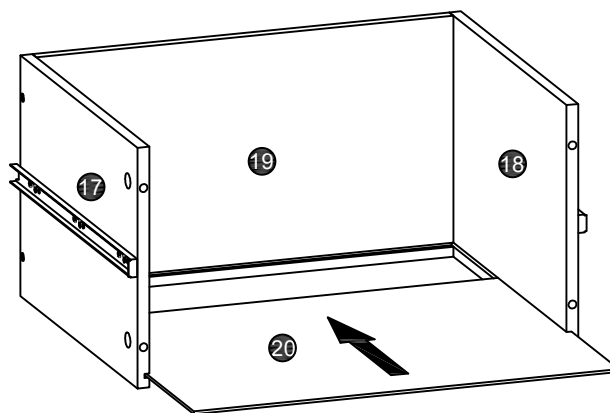

12

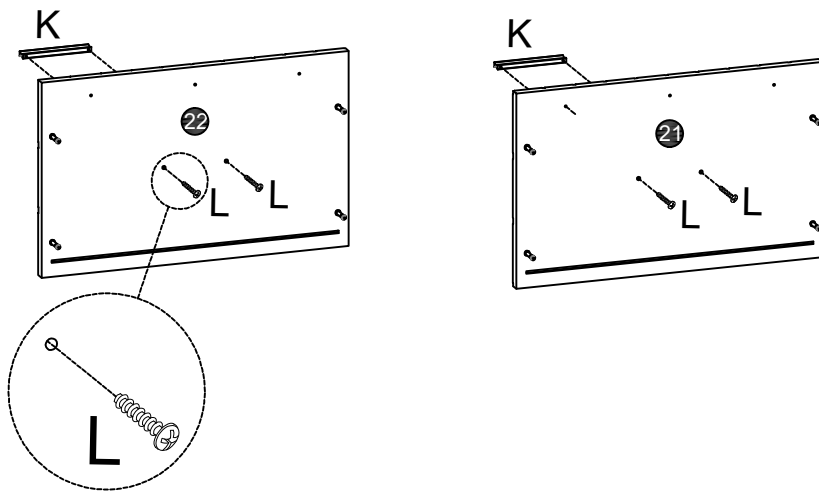

x2

13





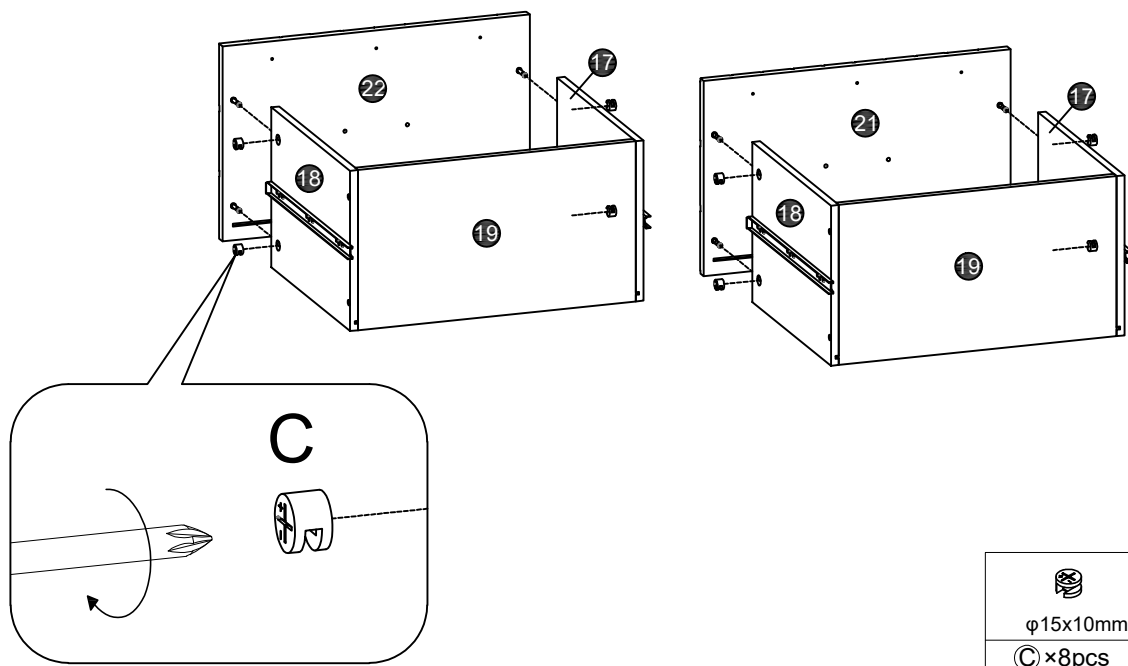

	
8x15x105mm	4x18mm
K × 2pcs	L × 4pcs

14

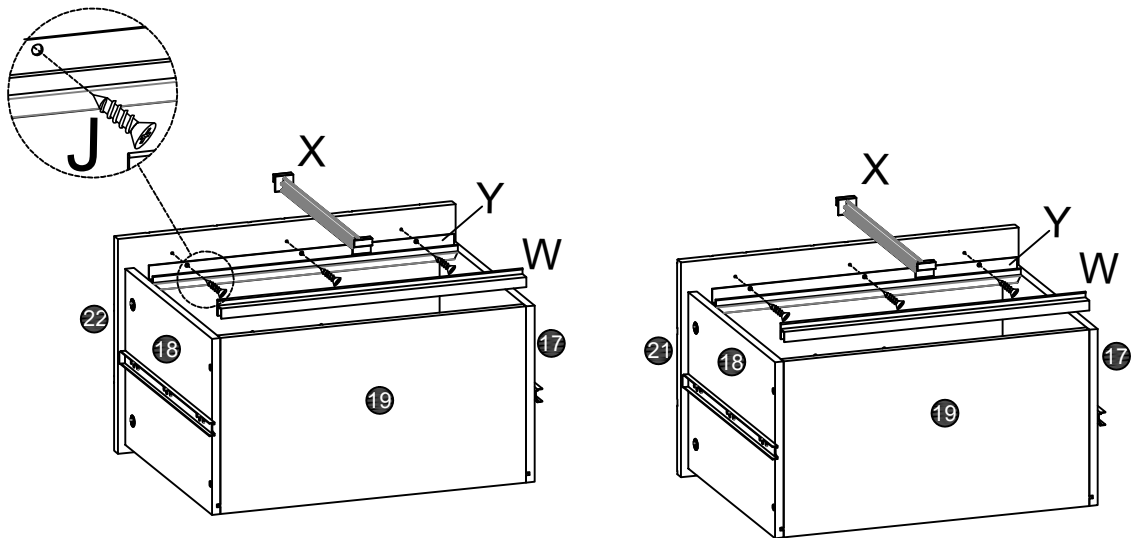

15



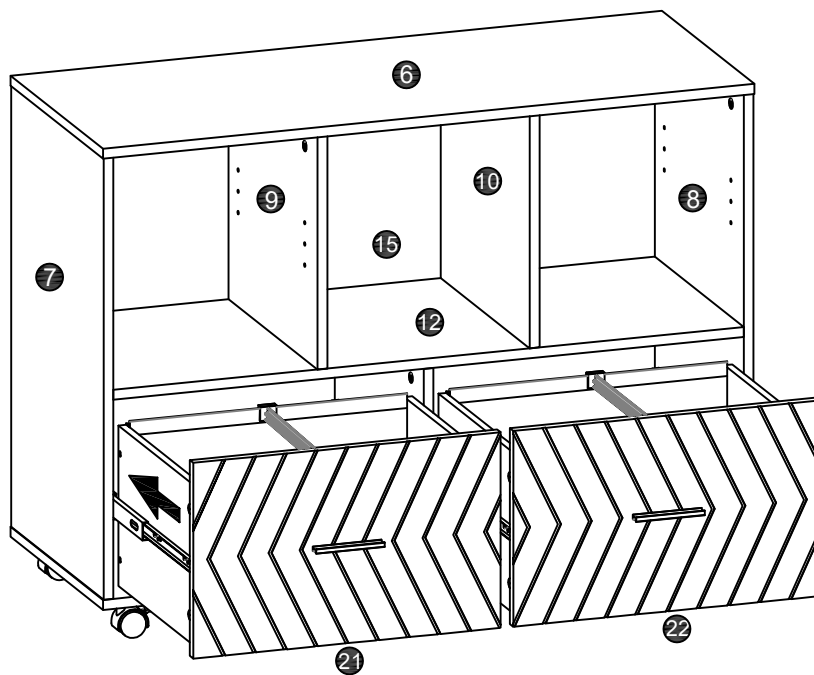

			
426×22×16mm	426×35×16mm	3.5×14mm	318×25×22mm
W ×2pcs	Y ×2pcs	J ×6pcs	X ×2pcs

16



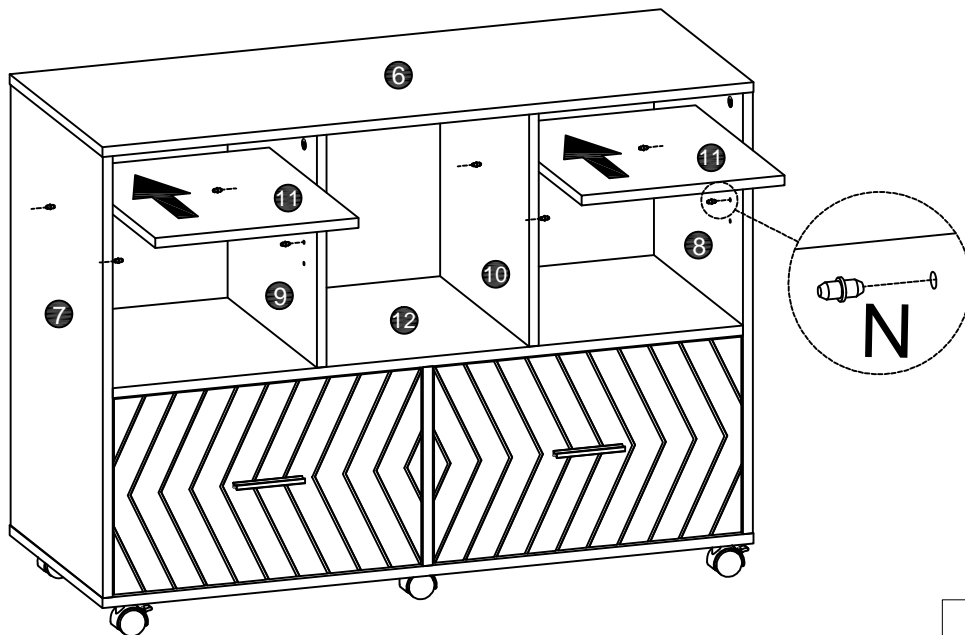

17

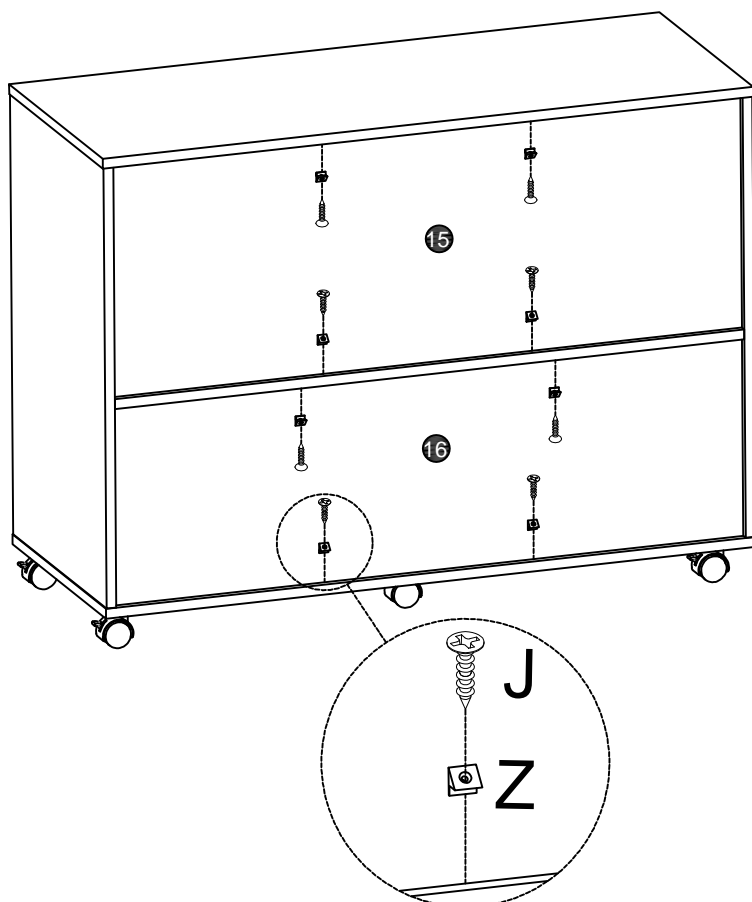

φ5x13mm
N ×8pcs

18



	
14x14x9mm	3.5x14mm
Z ×8pcs	J ×8pcs

19

