

HELIOS X CEILING/CANOPY

INSTALLATION, USAGE, & CARE GUIDE

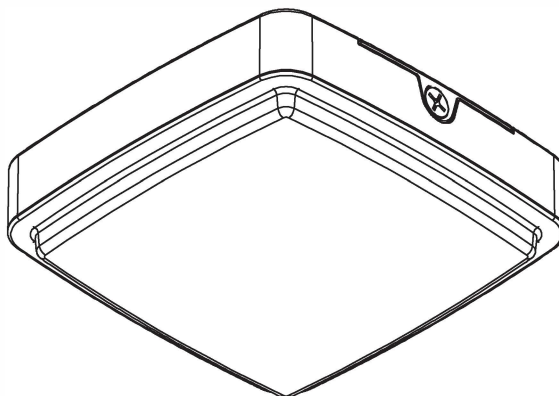

Questions? / Missing Parts? / Need Accessories?

Before returning to the store, call, text, or email PROBRITE
Customer Care 9am-5pm EST Monday to Friday.

1-844-507-5651

support@PROBRITE.com

PROBRITE.COM

TABLE OF CONTENTS

Table of Contents	2	Hardware Included.....	4
Safety Information	2	Installation	5
Pre-Installation	3	Operation	9
Planning Installation.....	3	Care & Cleaning	9
Specifications.....	3	Troubleshooting	10
Tools Required.....	3	Warranty	10
Package Contents.....	4		

SAFETY INFORMATION

IMPORTANT

THIS PRODUCT MUST BE INSTALLED IN ACCORDANCE WITH THE APPLICABLE NATIONAL ELECTRICAL CODE AND LOCAL BUILDING CODES BY A PERSON FAMILIAR WITH THE CONSTRUCTION AND OPERATION OF THE PRODUCT AND THE HAZARDS INVOLVED.

PRECAUTIONS

- Please read and understand this entire manual before attempting to assemble, install, or operate this light fixture.
- This light fixture requires a 120-277 Volt AC power source.
- Some codes require installation by a qualified electrician.
- This light fixture must be properly grounded.
- Make sure connections are secure using wire nuts, crimp-on lugs or other approved connecting devices
- This light fixture should be installed outdoors to the ceiling.



WARNING: Turn the power off at the circuit breaker or fuse. Place tape over the circuit breaker switch and verify power is off at the light fixture.



WARNING: Risk of fire. Keep the fixture at least 3 in. (76mm) from combustible materials.



CAUTION: Burn hazard. Allow the light fixture to cool before touching.



NOTICE: If dimming desired, use a 0-10V dimming switch.



INFORMATION: The device is tested and found to comply with Part 15 of the FCC Rules. Operation is subject to two conditions: (1) This device may not cause harmful interference and, (2) this device must accept any interference received, including any interference that may cause undesired operation.

These limits are designed to provide reasonable protections against harmful interference when the equipment is operated in a commercial environment.

PRE-INSTALLATION

PLANNING INSTALLATION

Before installing the light fixture, ensure that all parts are present. Compare parts with the **Hardware Included** and **Package Contents** sections. If any part is missing or damaged, do not attempt to assemble, install, or operate this light fixture.

SPECIFICATIONS

MODEL	Helios X
Lumens (Light Output)	4000 Lumens
Watts (Power Consumption)	38 Watts LED
Replaces	250W Incandescent
Lumens/Watts (Efficacy)	114 Lumens per watt
Power Requirements (Input Voltage)	120-277VAC
Light Color (CCT)	4000 Kelvin (Bright white)
Dimmable	0-10V Dimming

TOOLS REQUIRED



Phillips screwdriver



Wire strippers/cutters



Circuit tester



Silicone sealant



Work gloves



Ladder



Safety goggles

PRE-INSTALLATION (CONTINUED)

PACKAGE CONTENTS

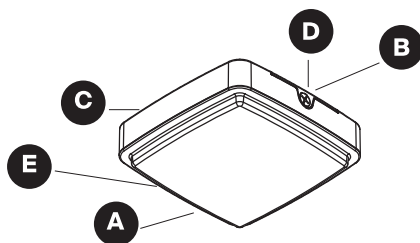

Part	Description	Quantity
A	Light fixture	1
B	Conduit entry plug	4
C	Locking spring	1
D	Mounting plate with gasket (pre-installed)	1
E	Hands-free install hook	1

HARDWARE KIT



NOTE: Hardware not shown to actual size.

AA



BB



Part	Description	Quantity
AA	#8-32 x 3/4" Phillips head screw	2
BB	Wire nuts	3

INSTALLATION

1 FOR BEST RESULTS

- The fixture can be mounted in the following two ways:
 - **Junction Box Mount:** Mount the light fixture to a standard recessed junction box. (fig 2)
 - **Surface Conduit Mount :** The fixture can also be mounted directly on the ceiling surface using conduit entry.
- Install fixture 8-20 feet above the ground.

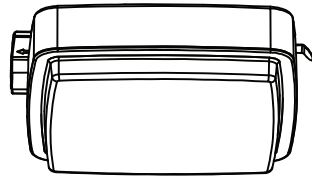

(fig 1). **Ceiling Mount**

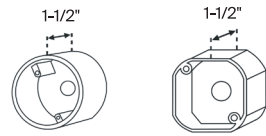

(fig 2).

Round

Octagonal/Square

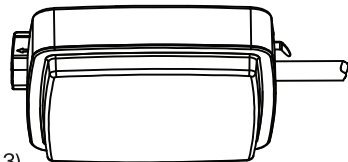

(fig 3).

Conduit Mount



NOTE: Mounting plate (D) mounts to standard recessed junction boxes. Junction box must be at least 1-1/2 inch deep for proper surface mount installation (fig 1).

2 SHUT OFF ELECTRIC POWER OFF

- Verify wall switch is in OFF position (fig 4).
- At the main electrical panel, turn off the circuit breaker that supplies power to the junction box you are working on (fig 5).
- For screw-in type fuses, unscrew the fuse that supplies power to the junction box you are working on (fig 6).

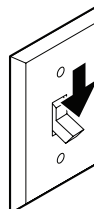

(fig 4).

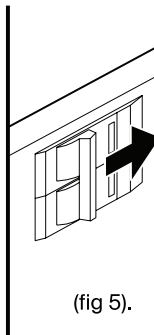

(fig 5).

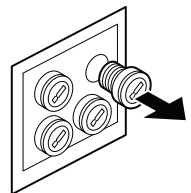

(fig 6).

INSTALLATION (CONTINUED)

3 REMOVE THE MOUNTING PLATE



NOTE: The mounting plate (D) comes pre-assembled on the light fixture (A) for shipping.

- Remove the mounting plate (D) from the back of the fixture by lifting the locking spring (C) and slide the mounting plate forward until mounting plate can be lifted and removed.

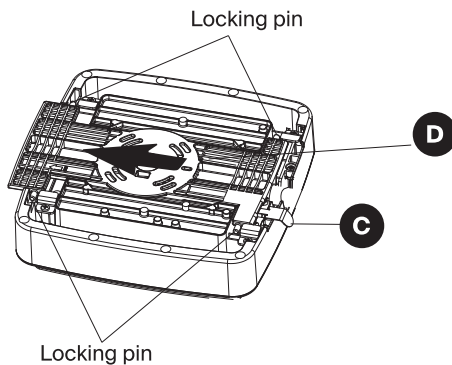

(fig 7).

4 INSTALL THE MOUNTING PLATE

Junction Box Mount

- Route the junction box wires through the large center hole in the mounting plate (D).
- Align the holes on the mounting plate (D) with the holes on your junction box. Use two #8 screws (AA) to attach the mounting plate (D) to the junction box. (fig. 8)

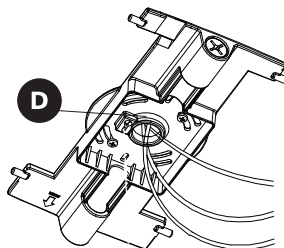

(fig 8).

Surface Conduit Mount

- Mark and drill two holes on the ceiling surface for the desired location of the mounting plate (D). Use two or more suitable screws (provided by others) to secure the mounting plate (D) to the ceiling surface. (fig. 9)
- Remove one or both conduit entry plugs (B). Carefully thread electrical wires through the mounting plate conduit entry. Install and secure conduit.

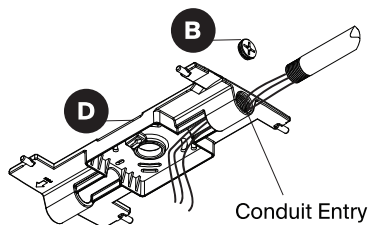

(fig 9).

INSTALLATION (CONTINUED)

5 MAKE THE ELECTRICAL CONNECTIONS

- For hands-free operation, use the ball lanyard attached to the fixture to hang in the keyhole slot on the mounting plate (D). (fig. 10)

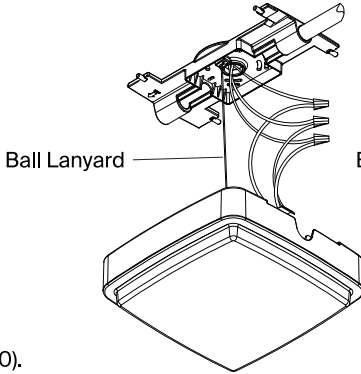

(fig 10).

Conduit Mount

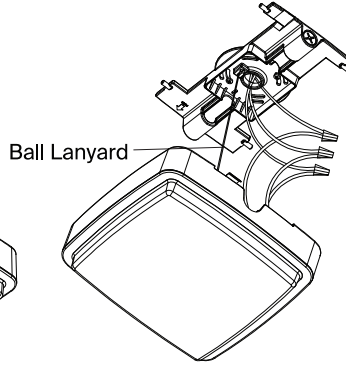

Junction Box Mount

FOR NON-DIMMING ELECTRICAL WIRING

(Follow these steps when NOT wiring to a 0-10V dimmer)

- Connect lighting fixture black wire to supply black wire (line), lighting fixture white wire to supply white wire (common), and the lighting fixture green wire to the supply ground wire (fig 11).
- **For the purple and gray fixture wires** individually terminate fixture's purple and gray wires with wire nuts to prevent shorting (fig 11).

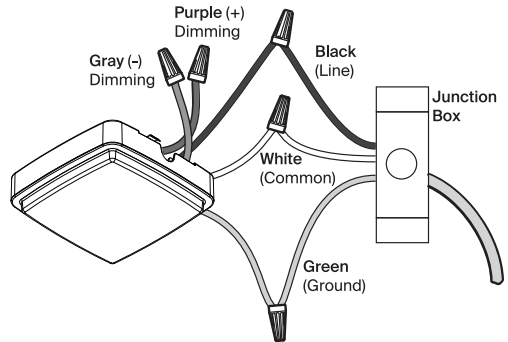

Non-Dimming Wiring Diagram

Follow this diagram when NOT wiring to a 0-10V dimmer

(fig 11).



NOTICE: Leave Purple & Gray wires terminated & separated when NOT connecting to a 0-10V dimmer. DO NOT connect the purple and gray wires to any other wires unless wiring to a 0-10V dimmer.

INSTALLATION (CONTINUED)

FOR ELECTRICAL WIRING TO 0-10V DIMMER

(Follow these steps when wiring to a 0-10V dimmer)

- Connect lighting fixture black wire to supply black wire (line), lighting fixture white wire to supply white wire (common), and the lighting fixture green wire to the supply ground wire.
-

For dimming wires, when connecting to a 0-10V dimmer, connect the lighting fixture purple wire to the dimmer switch purple wire (+ DIM) and the lighting fixture gray wire to the dimmer switch gray wire (- DIM). (fig 12)

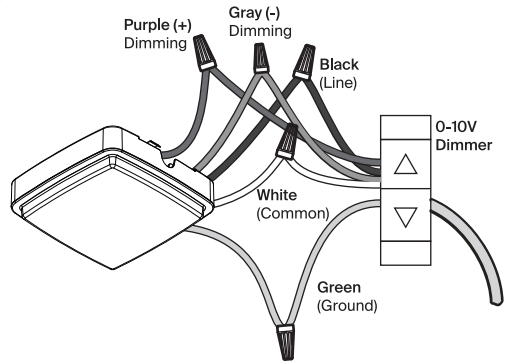

Dimming Wiring Diagram

Follow this diagram when wiring to a 0-10V dimmer

(fig 12).



TIP: Hold stripped ends near each other and align any frayed strands (do not twist wires).

Push the wires into wire nut (AA) and use your fingers to twist the wire nut clockwise until tight. Check for tightness by pulling wires.

6 MOUNT THE LIGHT FIXTURE

- Once the fixture is wired, place the light fixture onto the mounting plate (D) so the locking pins are positioned as shown in (fig 13).
- Slide the fixture forward on the mounting plate until locking spring (C) “clicks”.

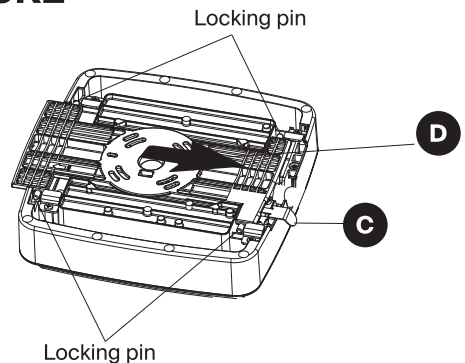

(fig 13).

INSTALLATION (CONTINUED)

7 CAULK AROUND THE LIGHT FIXTURE

- Caulk around the light fixture and surface with silicone sealant (not included). (fig 14)

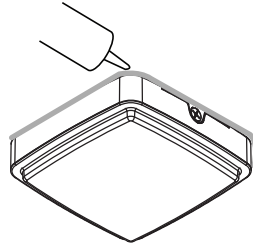

(fig 14).



NOTICE: Failure to properly caulk around the light fixture and mounting surface could lead to water damage and is not covered under warranty.

OPERATION

SWITCH-CONTROLLED

Switch-controlled operation enables the light fixture to turn ON and OFF by flipping a standard light switch. To add automatic Dusk to Dawn control or photocell, external sensor like a photo-control and timer is required (sold separately).

SWITCH



CONTROLLED

- Once the fixture is installed, turn power back on from the circuit breaker and switch.
- Flip switch ON and OFF to ensure light functions properly.



NOTE: Fixture is dimmable when used with a 0-10V dimming switch.



NOTE: NOTE: For automatic dusk-to-dawn control, add an external photocell or sensor (with timer) (sold separately).

CARE AND CLEANING

- Shut off main power supply before cleaning the product. To prolong the original appearance, clean the light fixture with clear water and a soft, damp cloth only.
- Do not use abrasive cleaners or cleaners that contain alcohol. Do not apply paints, solvents, or any other chemicals on this light fixture. They could cause a premature deterioration of the finish and may void the warranty.
- Do not spray the light fixture with a hose or power washer.

TROUBLESHOOTING

If Light does not come on:

- Verify that the power is turned ON from the circuit breaker and wall switch.
- Verify the wiring for the fixture is done properly.
- Verify the line voltage is correct.

If Light flickers:

- Use 0-10V dimming switch or standard ON/OFF switch

5-YEAR LIMITED WARRANTY

This is a limited warranty offered by Probrite for a period of five years from the date of purchase to its customers. Probrite warrants to customers that the products will be free from defects in material and workmanship. The obligation of Probrite under this warranty is limited to the provision of replacement of products and is extended to the original purchaser of the product on presenting valid purchase receipt or other proof of date of original purchase acceptable to Probrite. The receipt is required for rendering the warranty performance. Any warranty claims without original proof of purchase would not be accepted.

It should be noted that the warranty does not apply to Probrite products that have been altered or repaired by unauthorized personnel, have been subjected to neglect, abuse, misuse or accident or damages caused during shipping. Any other products not manufactured by Probrite which have been supplied, installed and/or used in conjunction with Probrite products are not covered under this warranty. Any damages caused by replacements bulbs, LEDs or corrosion or discoloration of brass components are also not covered by this warranty.

Limitation of Liability:

In no event Probrite shall be liable for indirect, consequential, incidental or special damages, or lost profits. Probrite is not liable for any claims or damage arising out of or connected with the manufacture, sale, delivery, use, maintenance and repair or modification of Probrite products, or supply of any replacement parts that, exceed the purchase price of Probrite products giving rise to a claim. Labor charges to remove or install the fixtures will not be accepted.

To Claim:

Please contact PROBRITE customer service at 1-844-507-5651 or email support@PROBRITE.com and include your name, address and contact number, along with a copy of the purchase receipt and a brief description of the problem.

PROBRITE®

Questions? / Missing Parts? / Need Accessories?

Before returning to the store, call or email our
Lighting Specialists 9am-5pm EST Monday to Friday.

1-844-507-5651

support@probrite.com

www.probrite.com

RETAIN THIS MANUAL FOR FUTURE USE

Para las translaciones en español,
visit www.probrite.com/install