

INSTRUCTION MANUAL ENCLOSED

ATTENTION

**IF YOU HAVE ANY PROBLEMS OR QUESTIONS, EMAIL OR CALL
CUSTOMER SERVICE BEFORE YOU RETURN THIS PRODUCT TO THE
STORE WHERE IT WAS PURCHASED.**

****When emailing Customer Service, please include your **Order Number** and **platform of purchase** in the email subject for quicker assistance.**

INSTRUCTION MANUAL ENCLOSED





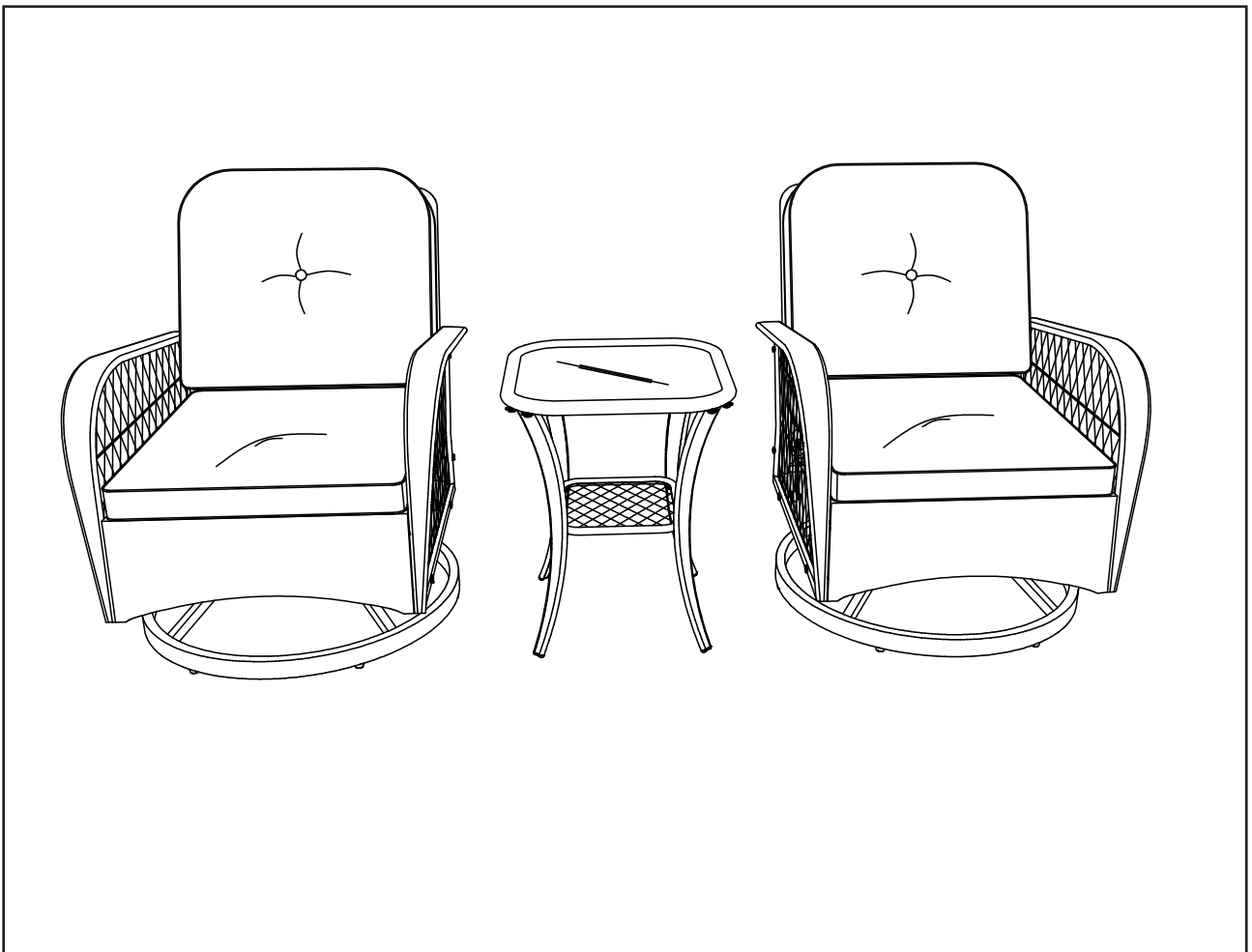





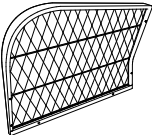
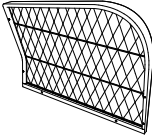
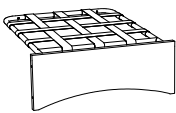
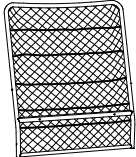
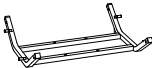
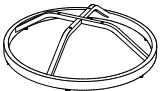

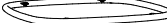

3PCS WICKER SWIVEL CHAIR SET

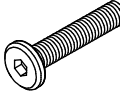
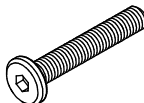
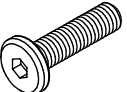
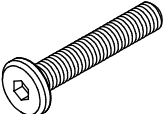
3PCS WICKER SWIVEL CHAIR SET ASSEMBLY INSTRUCTION

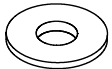

PARTS LIST

| Part | Description | Quantity |
|-----------------|-------------------------|----------|
| PARTS | | |
| 1 | Right arm | 2 |
| 2 | Left arm | 2 |
| 3 | Chair seat | 2 |
| 4 | Chair backrest | 2 |
| 5 | Support frame | 2 |
| 6 | Round leg frame | 2 |
| 7 | Cushion | 2 |
| 8 | Pillow | 2 |
| 9 | Table frame | 1 |
| 10 | Table legs | 4 |
| 11 | Table sheft | 1 |
| 12 | Glass tabletop | 1 |
| HARDWARE | | |
| A | Bolt M6x15 mm | 12 |
| B | Bolt M6x40 mm | 12 |
| C | Bolt M6x45 mm | 8 |
| D | Bolt M8x30 mm | 16 |
| E | Bolt M8x45 mm | 16 |
| F | Washer Ø6x14x1 mm | 32 |
| G | Washer Ø8x16x1 mm | 80 |
| H | Nut M8 mm | 32 |
| J | Turntable 190x190x25 mm | 2 |
| K | Glider Bearing | 8 |
| L | Wrench M13 - 90x25x2 mm | 1 |
| M | Allen key 4x98 mm | 2 |

| | | | | |
|---|--|---|---|--|
| 1  x2 | 2  x2 | 3  x2 | 4  x2 | 5  x2 |
| 6  x2 | 7  x2 | 8  x2 | 9  x1 | 10  x4 |
| 11  x1 | 12  x1 | A  M6×15 mm x12 | B  M6×40 mm x12 | C  M6×45 mm x8 |
| D  M8×30 mm x16 | E  M8×45 mm x16 | F  Ø6x14×1 mm x32 | G  Ø8x16x1 mm x80 | H  M8 mm x32 |
| J  190x190x25 mm x2 | K  Glider Bearing x8 | L  13 mm 90x25x2 mm x1 | M  4 mm x2 | |

PLEASE READ AND FOLLOW ALL SAFETY TIPS

GETTING STARTED

1. Before assembly, CAREFULLY use scissors or utility knife to cut and unwrap all parts. Make sure you do not discard the hardware.
2. Make sure that you have all the parts listed. If you are missing any parts, please email us. Please identify the parts you need and model number. Make sure to include your name and address.
3. Please include your **Order Number** and **platform of purchase** in the email subject, and one of our customer service representative will get back to you.

Warm Tips:

1. The plastic covers on some metal parts are just for product protection. Please remove it before assembly.
2. Please follow the sequence of AI during assembly.
3. Do not tighten the screws until all of them are in right positions.

1. Locate 1 chair seat (3) to 1 chair backrest (4) by the pre-drilled threads.
Use Allen Key (M) to tighten Bolts (B) and Washers (F).
Note: only tighten 80% (Photo 1).

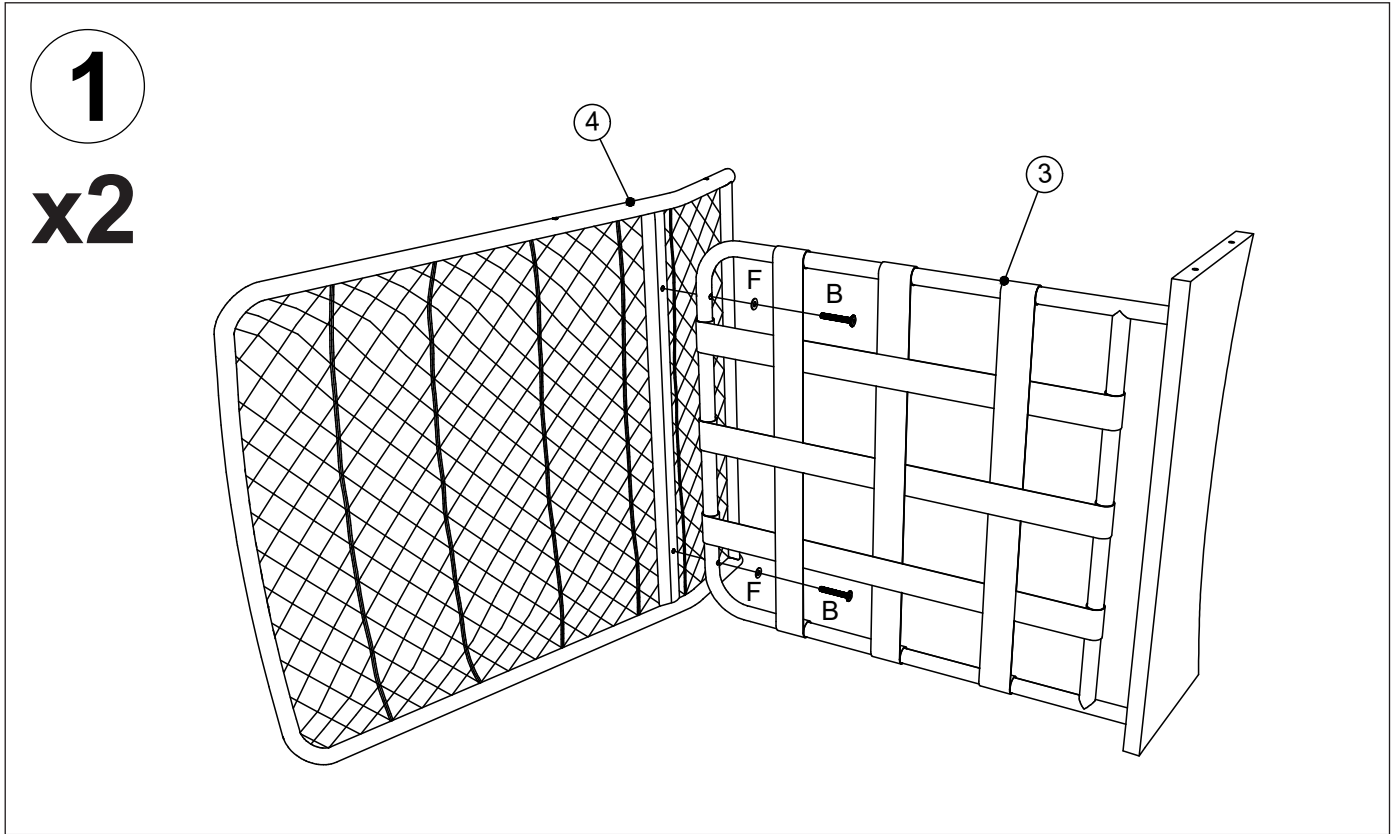

2. Locate the assembly installed in step (1) to 1 right arm (1) by the pre-drilled threads.
Use Allen Key (M) to tighten Bolts (C) and Washers (F).
Note: only tighten 80% (Photo 2).

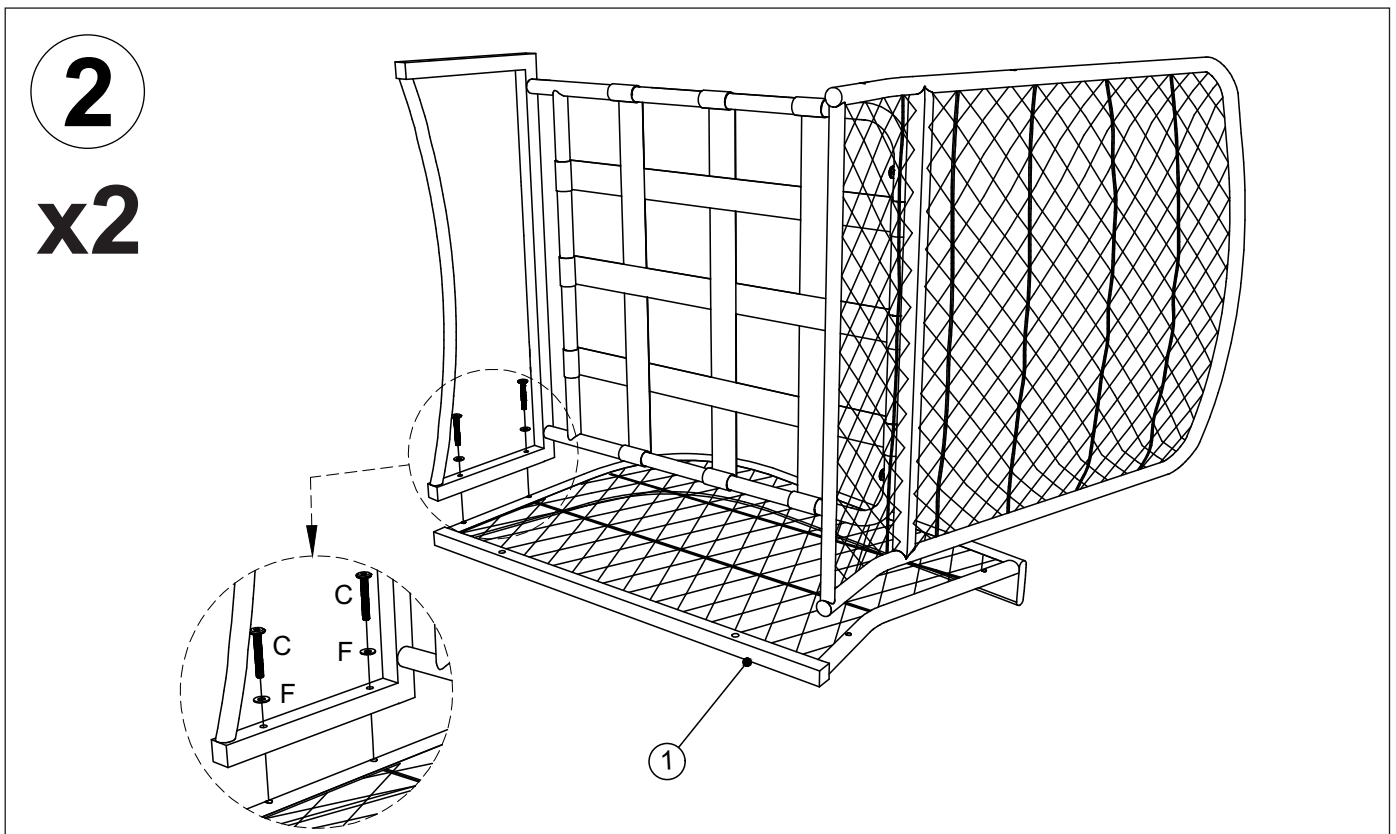

3. Locate right arm (1) to the chair backrest (4) by the pre-drilled threads.
Use Allen Key (M) to tighten Bolts (B) and Washers (F).
Note: only tighten 80% (Photo 3).

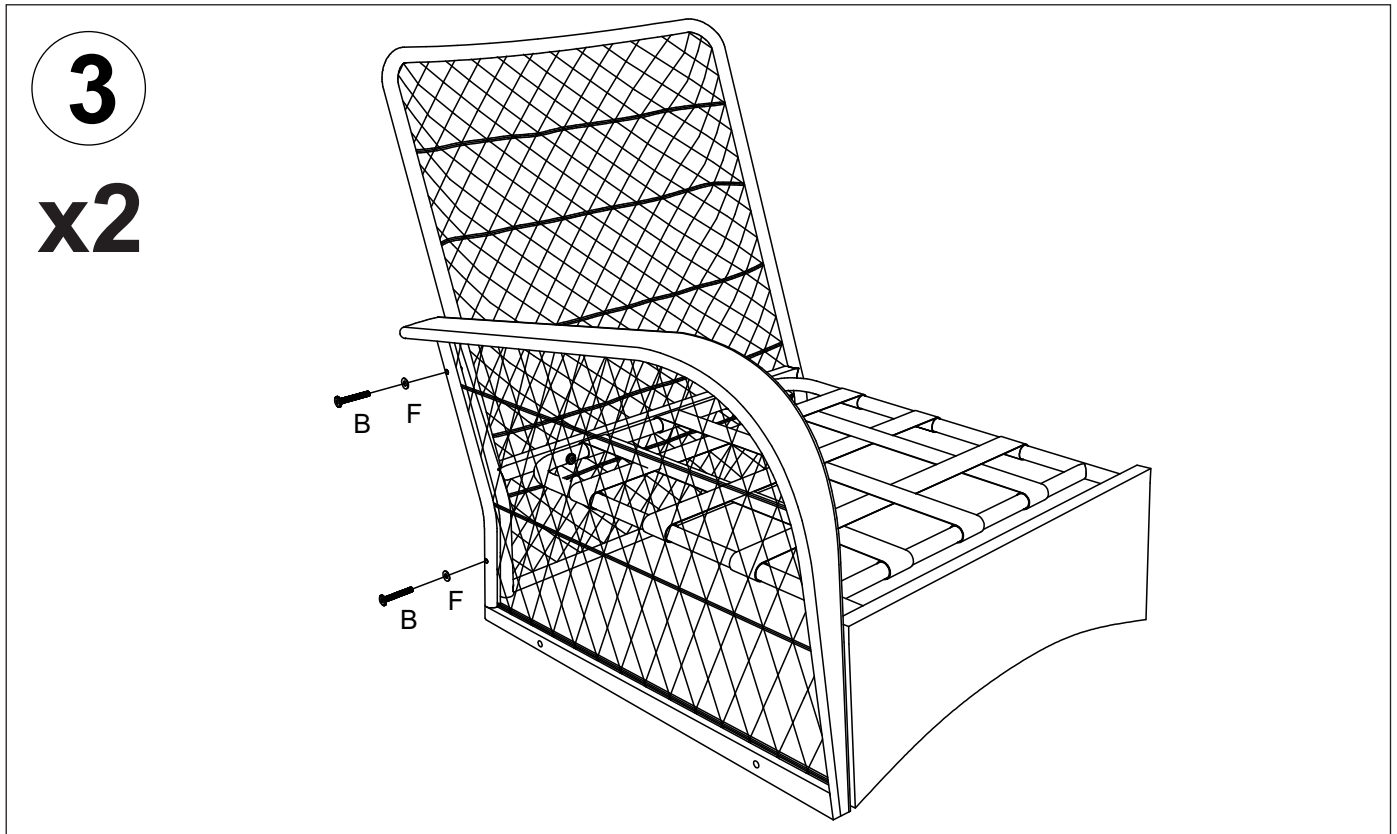

4. Locate the assembly installed in step (3) to 1 left arm (2) by the pre-drilled threads.
Use Allen Key (M) to tighten Bolts (C) and Washers (F).
Note: only tighten 80% (Photo 4).

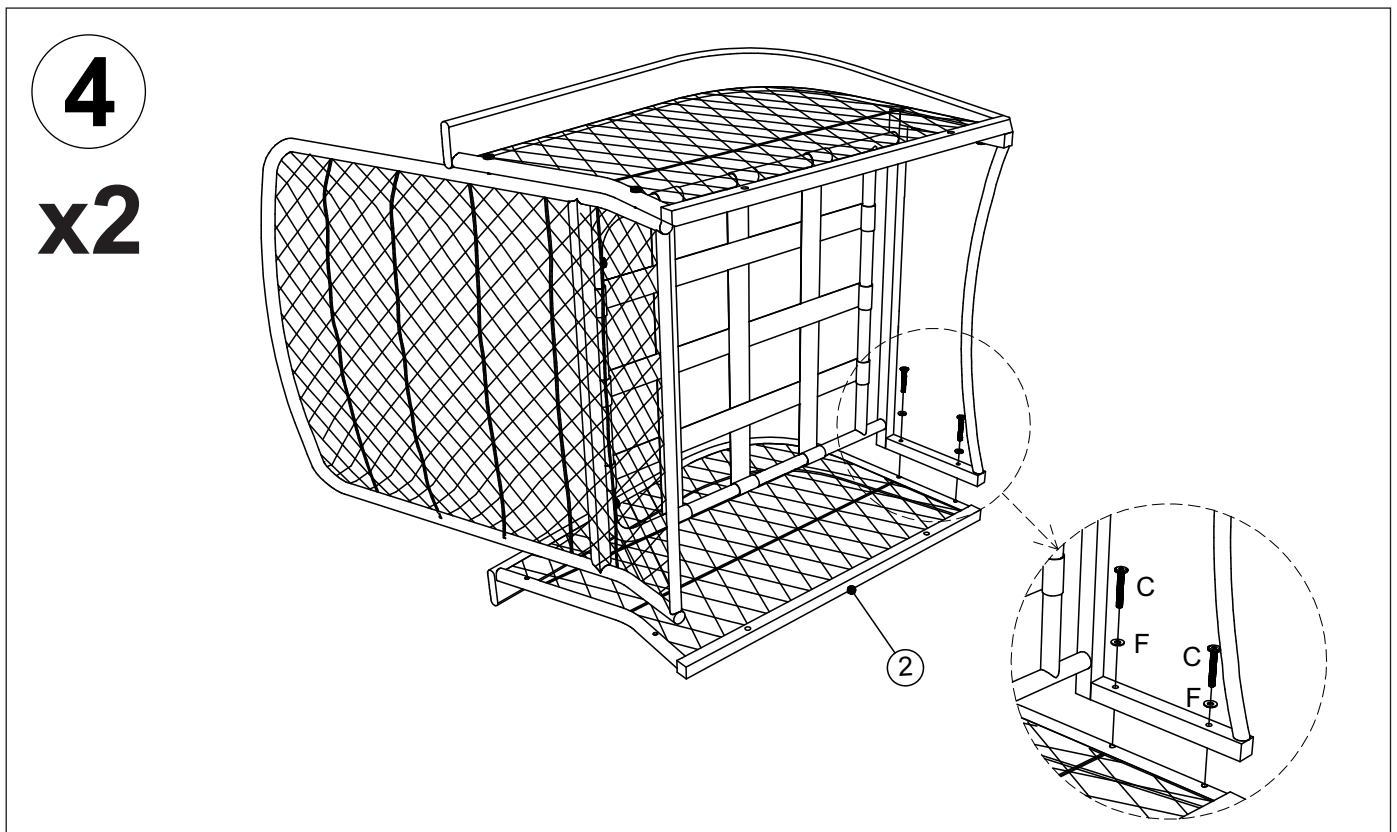

5. Locate left arm (2) to the chair backrest (4) by the pre-drilled threads.
Use Allen Key (M) to tighten Bolts (B) and Washers (F).
Note: only tighten 80% (Photo 5).

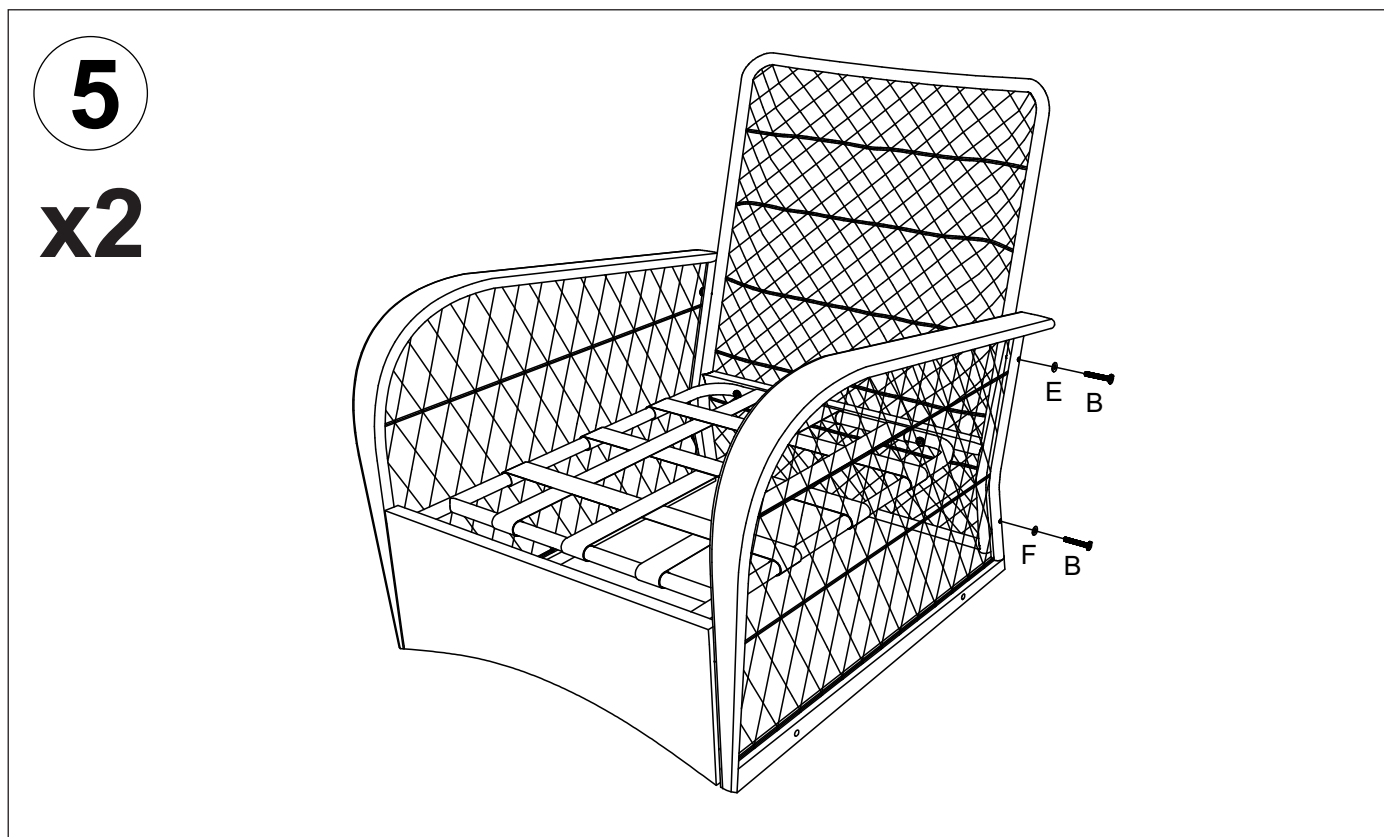

6. Locate 1 Turntable (J) to 1 round leg frame (6) by the pre-drilled threads.
Use Allen Key (M) to tighten Bolts (D), Washers (G), Nuts (H) and Wrench (L).
Note: only tighten 80% (Photo 6).

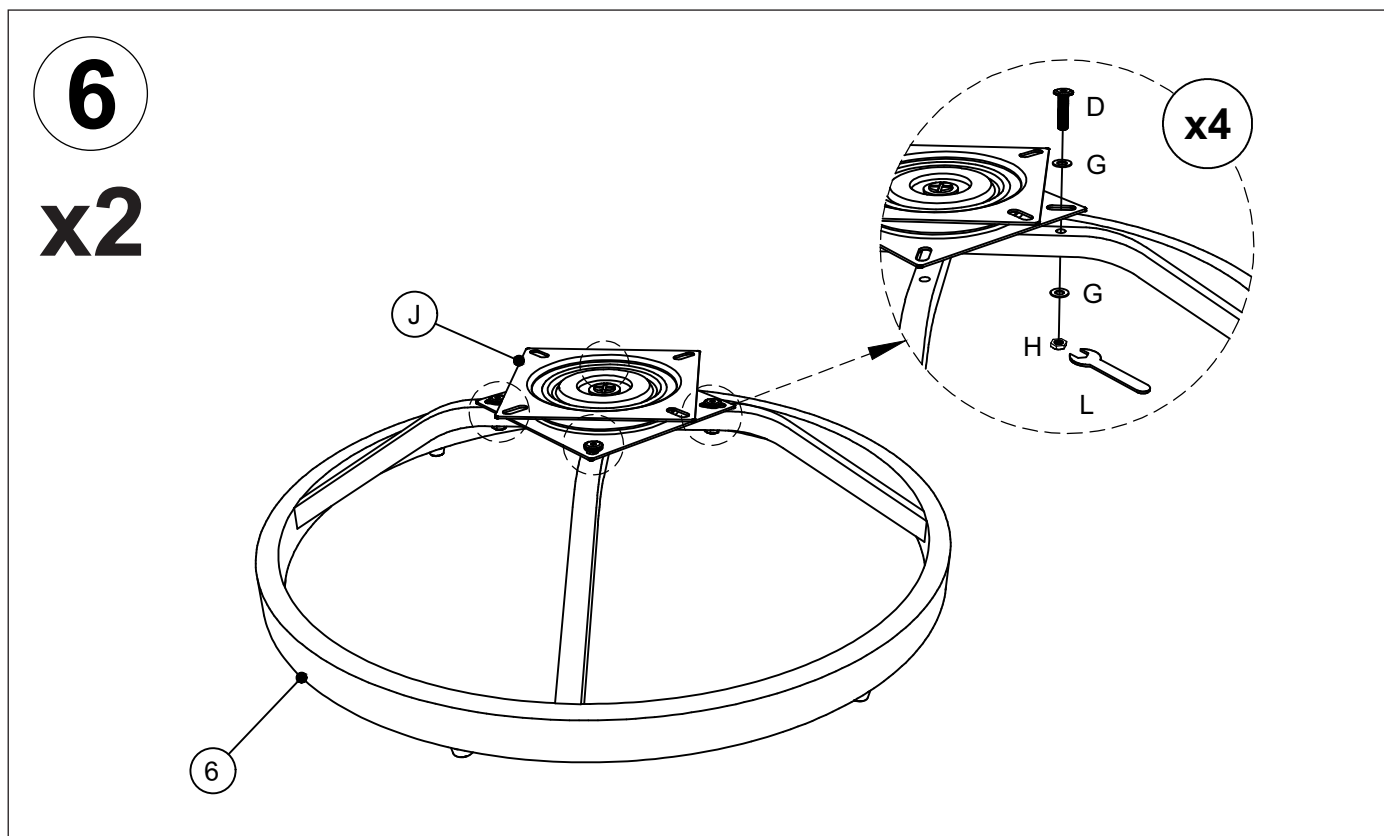

7. Locate the support frame (5) to the Turntable (J) by the pre-drilled threads.
Use Allen Key (M) to tighten Bolts (D), Washers (G), Nuts (H) and Wrench (L).
Note: only tighten 80% (Photo 7).

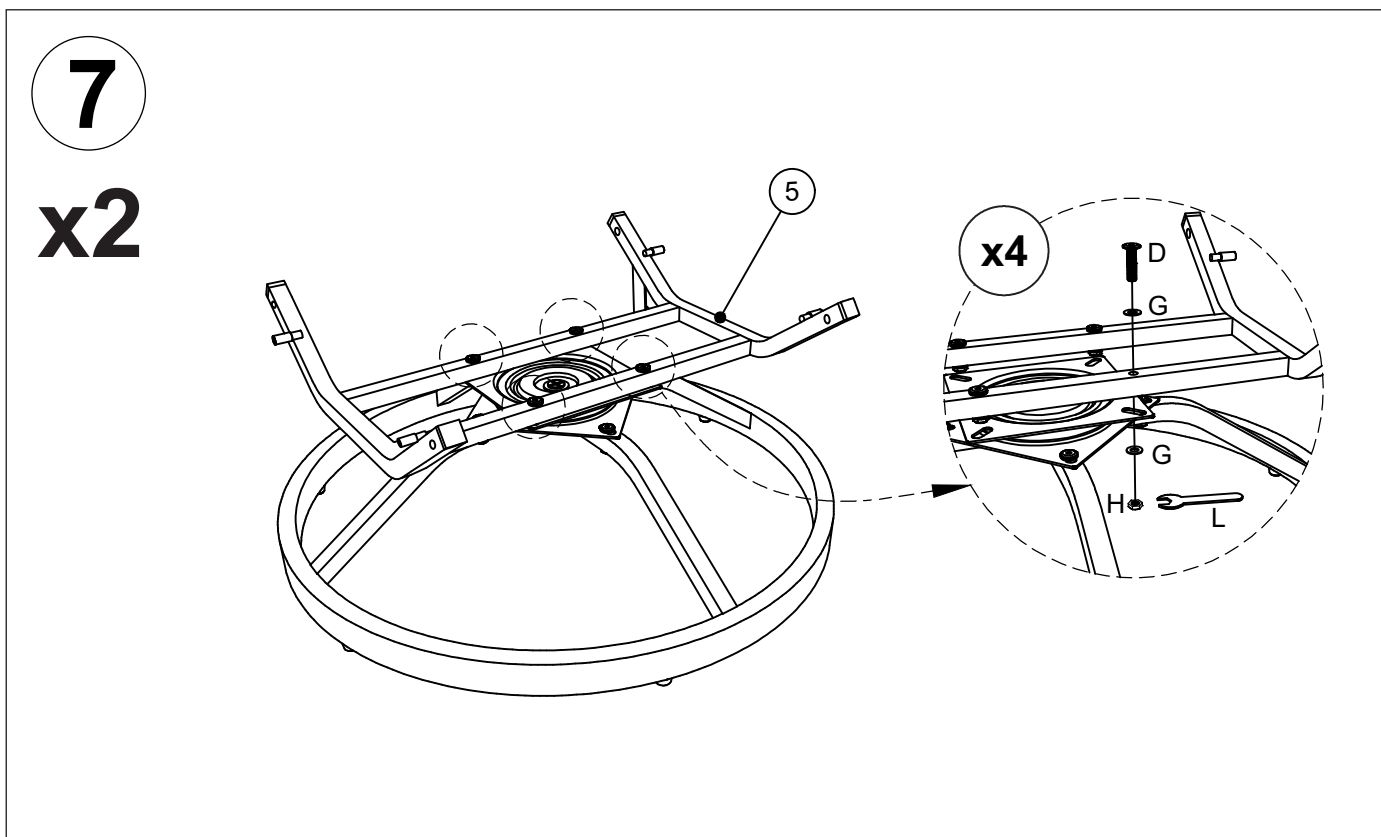

8. Locate and align 4 glider bearing (K) with the support frame (5) as shown in the picture, ensuring the glider bearing is oriented correctly.
Use Allen Key (M) to tighten Bolts (E) and Washers (G), Nuts (H) and Wrench (L).
Note: only tighten 80% (Photo 8).

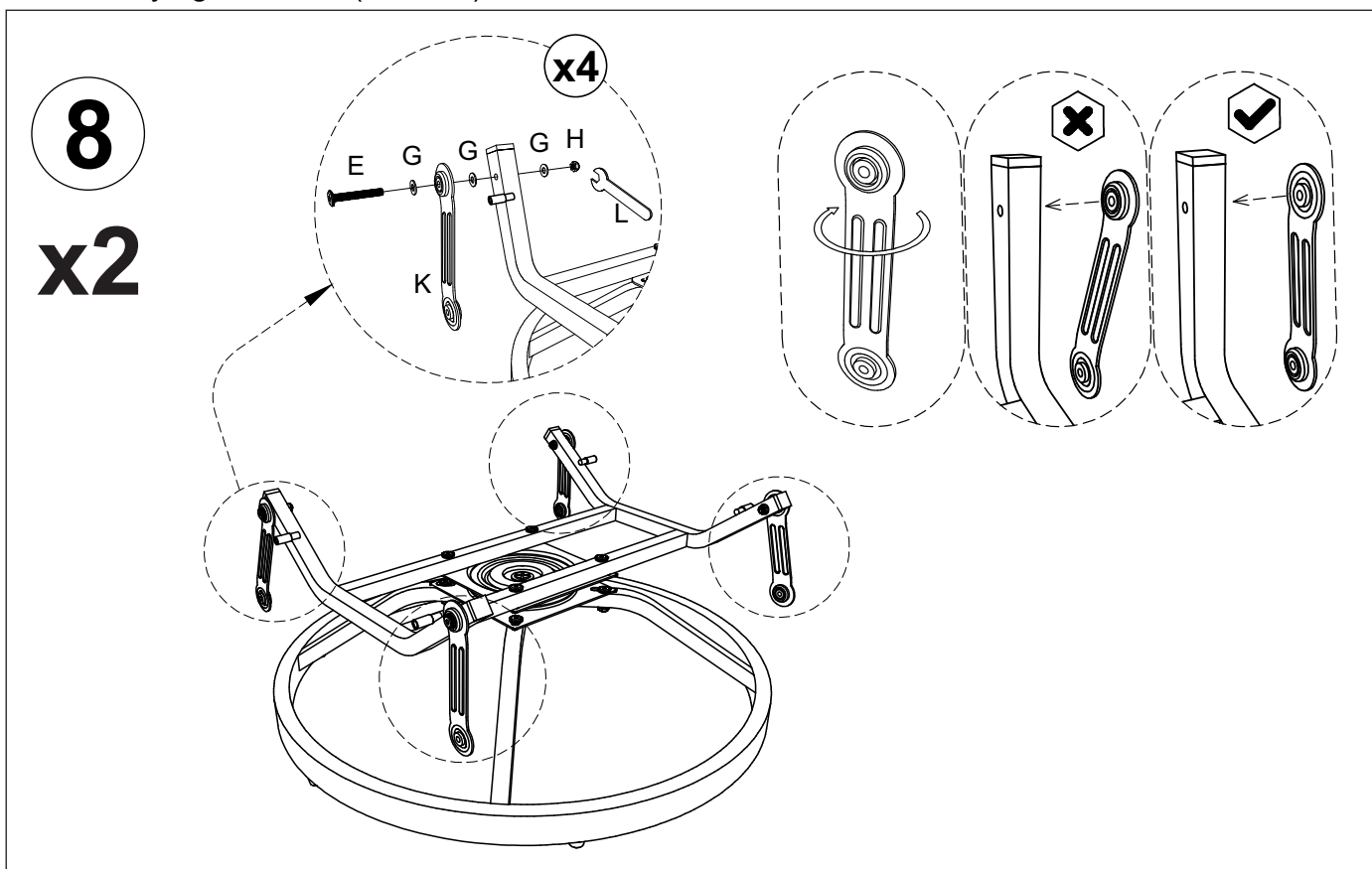

9. Locate the assembly installed in step (8) to the assembly installed in step (5) as shown in the picture (9).

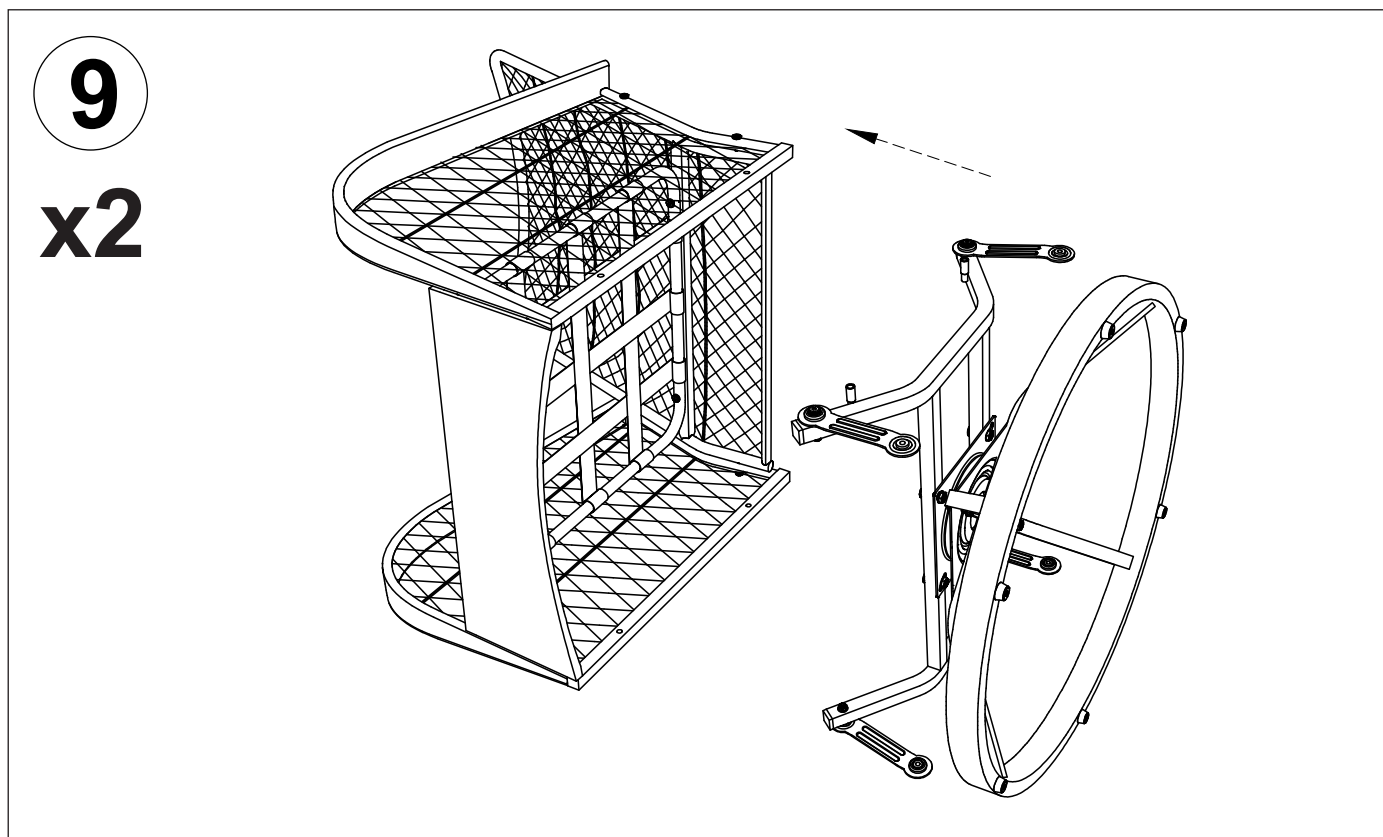

10. Use Allen Key (M) to tighten Bolts (E), Washers (G), Nuts (H) and Wrench (L).
Note: only tighten 80% (Photo 10).

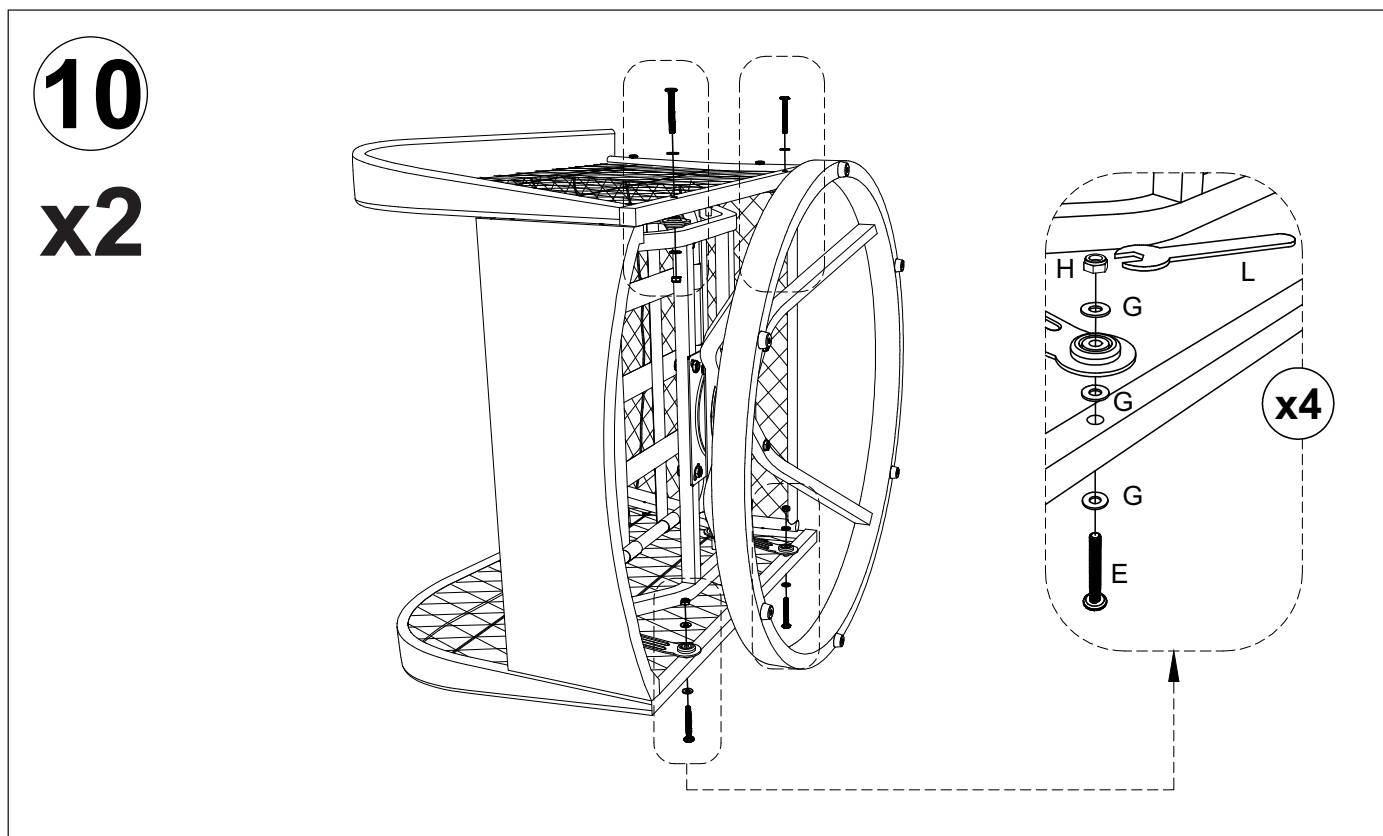

11. Use Allen Key (M) to tighten all Bolts 100%

Place 1 cushion (7) on the top chair seat, and then place 1 pillows (8) above it (Photo 11).

11

x2

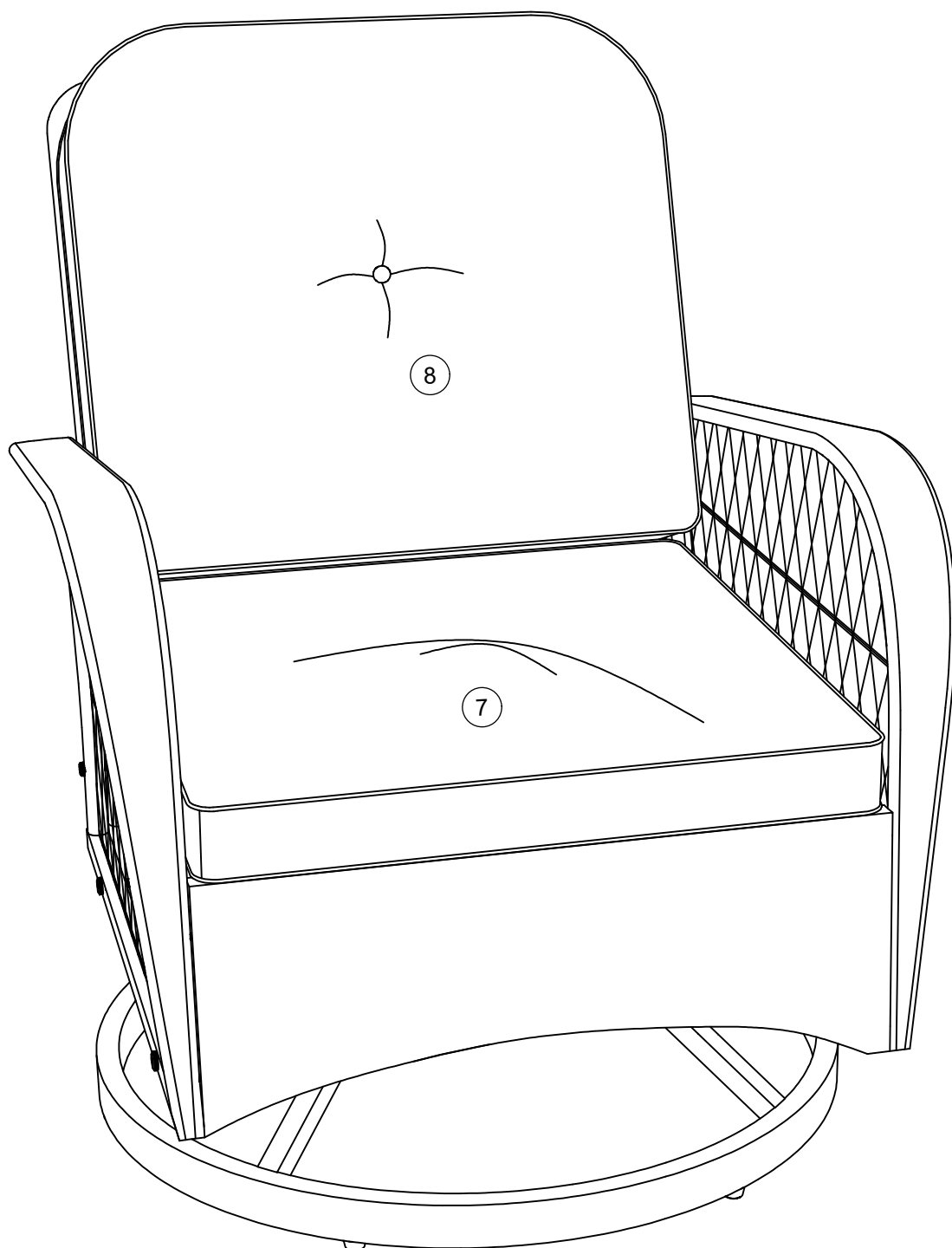

12. Locate 4 table legs (10) to the table frame (9) by the pre-drilled threads.
Use Allen Key (M) to tighten Bolts (A) and Washers (F).
Note: only tighten 80% (Photo 12).

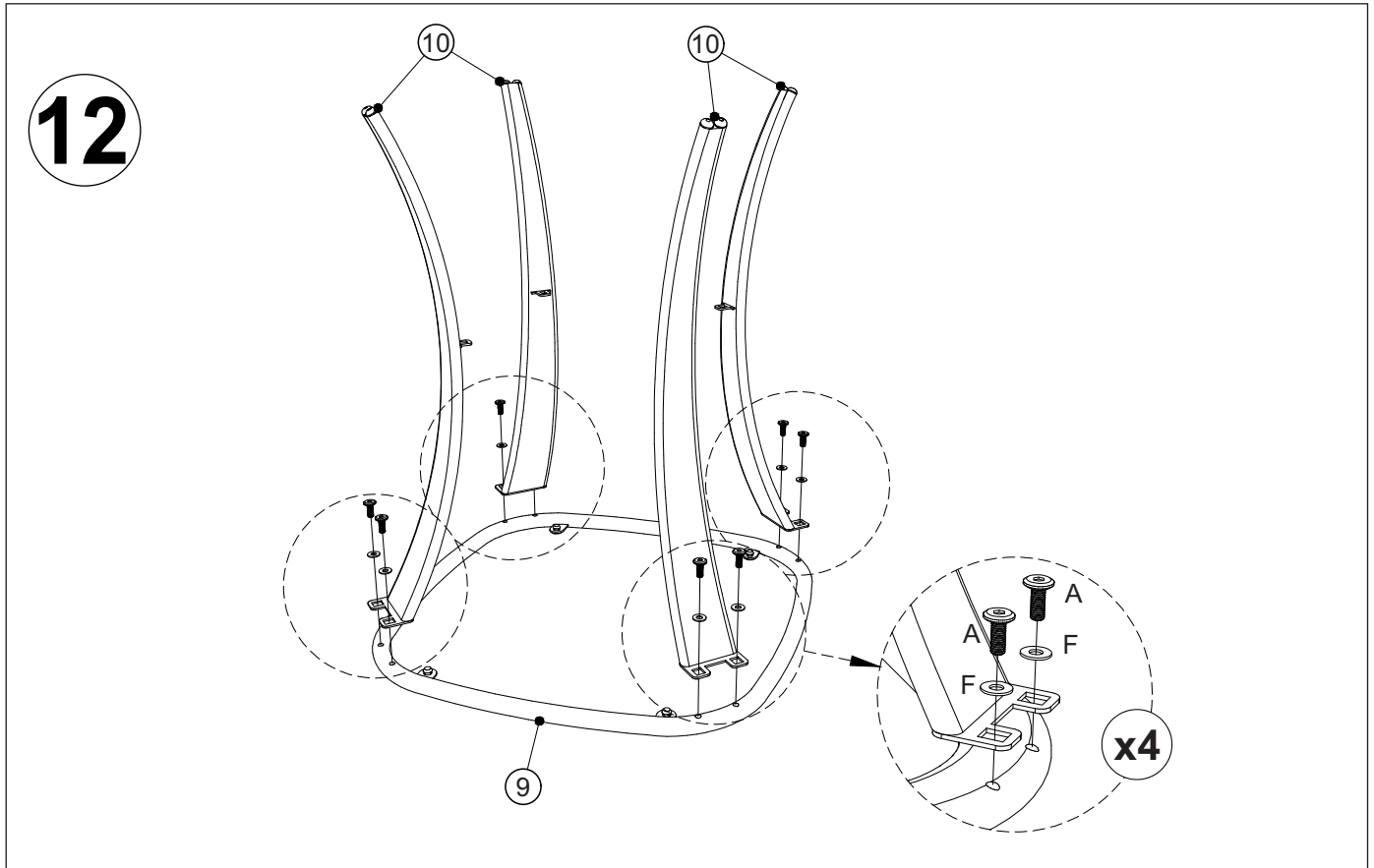

13. Locate 1 table sheft (11) to 4 table legs (10) by the pre-drilled threads.
Use Allen Key (M) to tighten Bolts (A) and Washers (F).
Note: only tighten 80% (Photo 13).

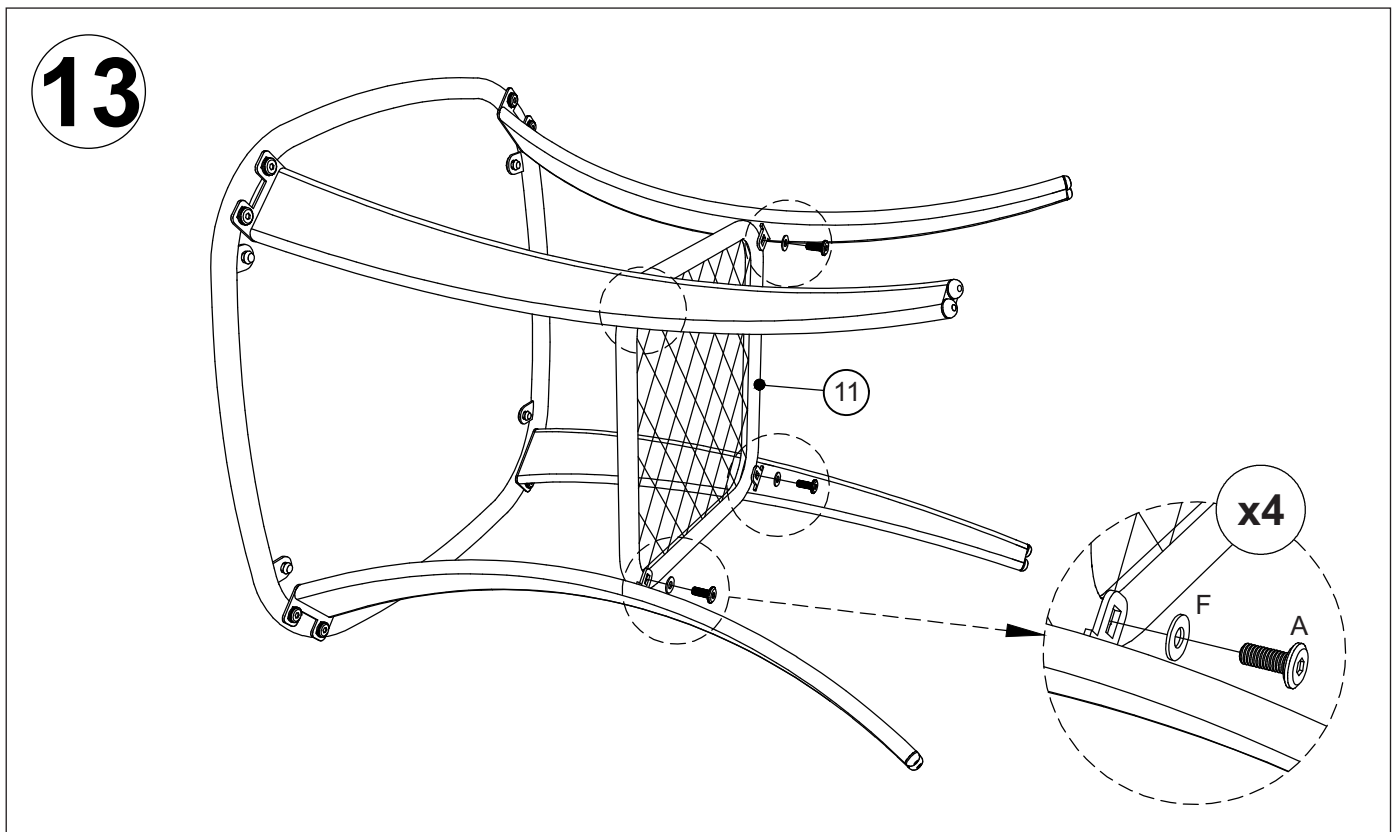

14. Use Allen Key (M) to tighten all Bolts 100%.
Carefully place glass tabletop (12) on the top table frame (9). Completed.

14

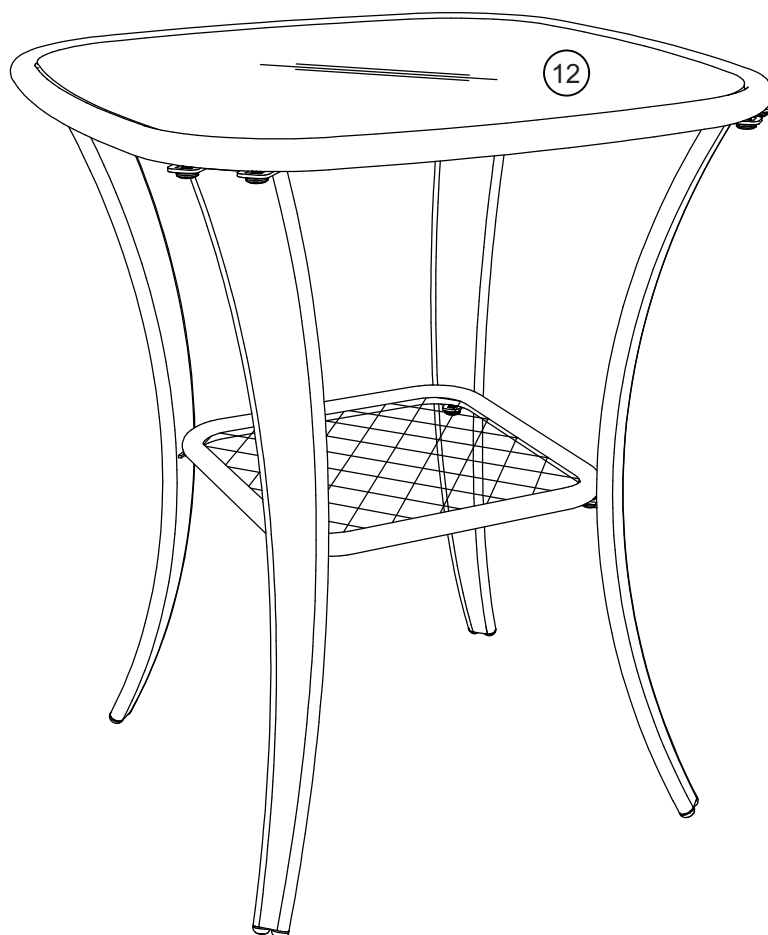

Till now you have finished the whole assembly and enjoy your furniture!