

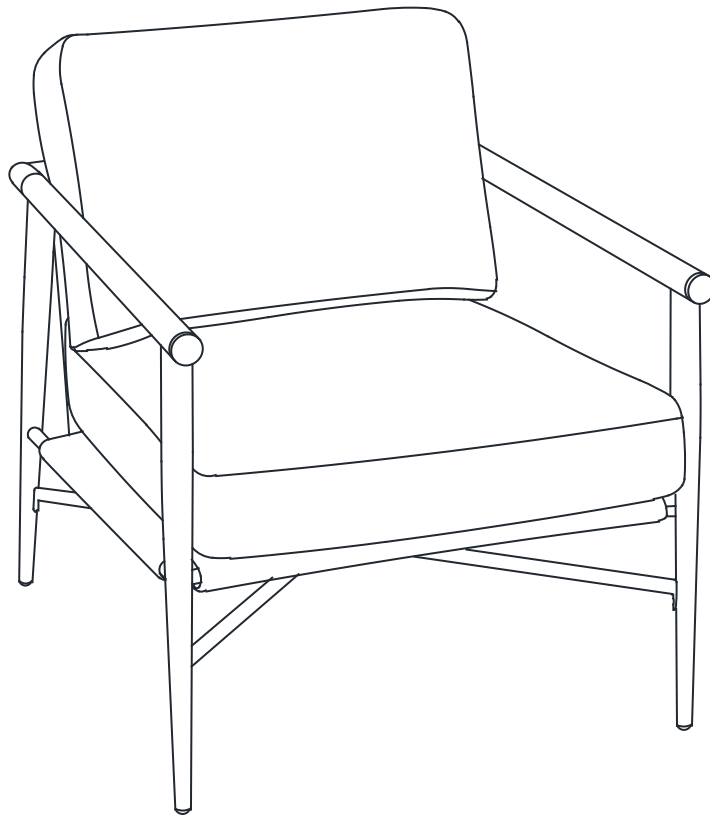









Assembly Manual Accent Chair

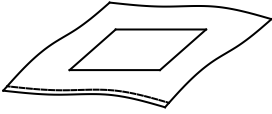
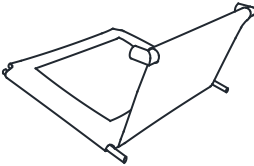
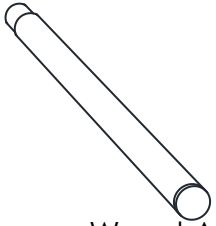
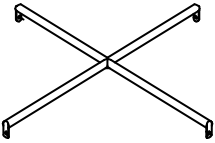
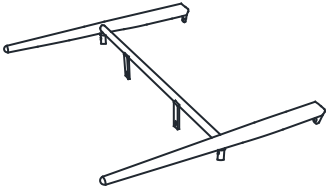

 **CAUTION**

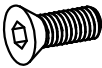
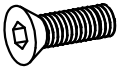
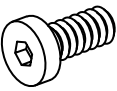
THIS ASSEMBLY MANUAL CONTAINS IMPORTANT SAFETY INFORMATION.
PLEASE READ AND KEEP FOR FUTURE REFERENCE.

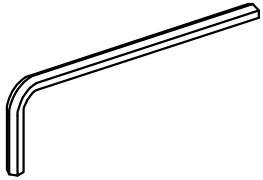
Assembly Manual

<p>Ax1</p>  <p>Back Cushion</p>	<p>Bx1</p>  <p>Seat Cushion</p>	<p>Cx1</p>  <p>Seat & Back</p>	<p>Dx2</p>  <p>Wood Arm</p>
<p>Ex1</p>  <p>X-Shaped Frame</p>	<p>Fx1</p>  <p>Front Leg</p>	<p>Lx1</p>  <p>Left Back Leg</p>	<p>Rx1</p>  <p>Right Back Leg</p>
<p>Gx1</p>  <p>Back Cover</p>	<p>Hx1</p>  <p>Seat Cover</p>	<p>Ix10</p>  <p>M6 x 16mm Bolt</p>	<p>Jx6</p>  <p>M6 x 20mm Bolt</p>
<p>Kx2</p>  <p>M6 x 18mm Bolt</p>	<p>Mx2</p>  <p>M6 Flat Washer</p>	<p>Nx2</p>  <p>M6 Spring Washer</p>	<p>Ox1</p>  <p>4# Allen Wrench</p>
<p>Px4</p>  <p>15mm Felt Pad</p>			

Please read through the instructions below to familiarize yourself with the parts and steps before assembly.

Note: Do NOT use power tools for assembly.

ASSEMBLY INSTRUCTIONS

- 1 Open the vacuum-packed bags containing the Seat Cushion (B) .
Note: Do NOT use sharp tools such as knives or scissors to open these bags as it could potentially damage the cushions. Please use your hands to gently pull the bags apart.

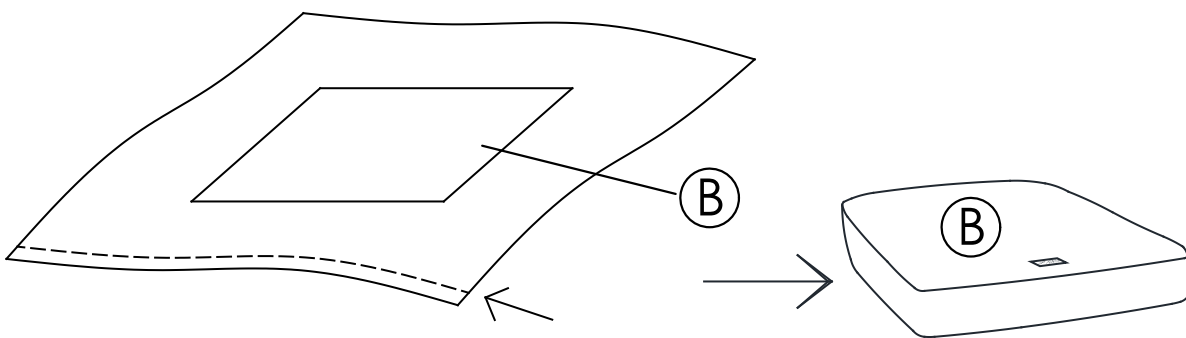

- 2 Unfold the Seat Cover (H) and Back Cover (G). Unzip them and take out the foam tubes inside.

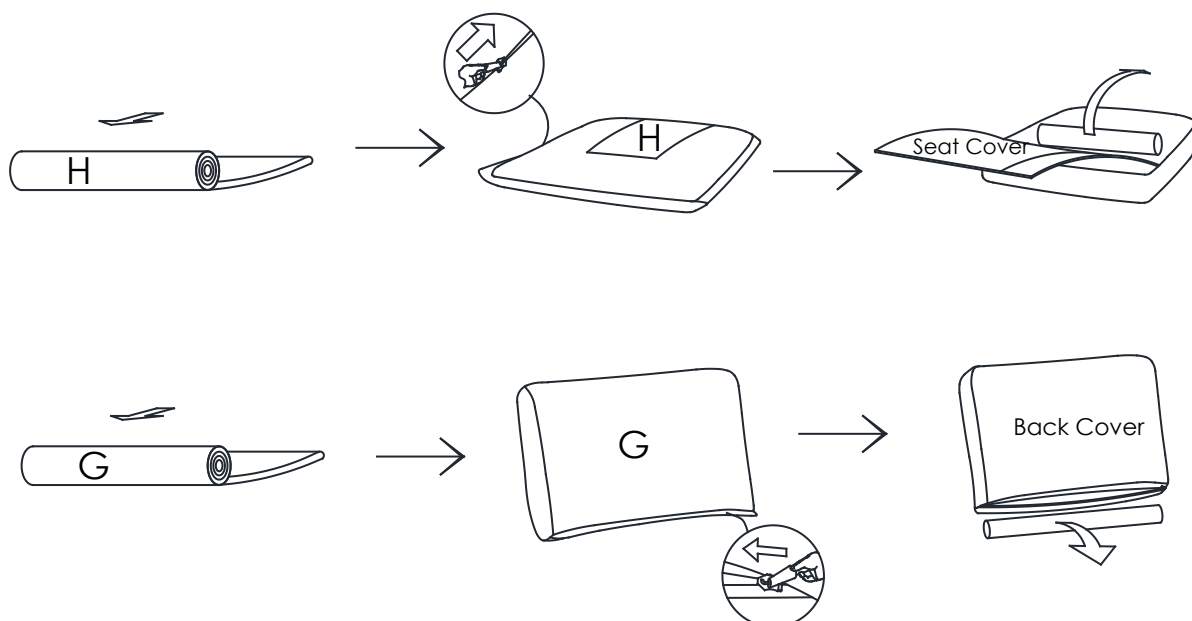

- 3** Put the Seat Cushion (B) into the Seat Cover (H) and zip it up.
Note: The seat cushion (B) has a specific orientation for top, bottom, front, and back.

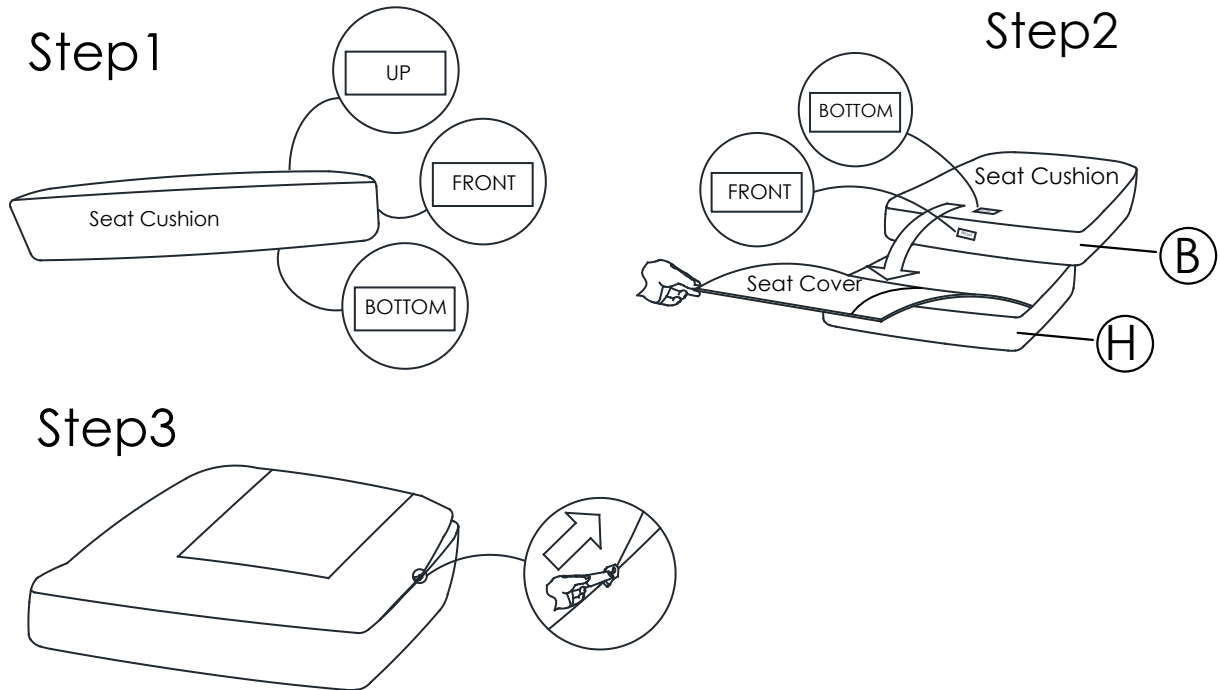

- 4** Put the Back Cushion (A) into the Back Cover (G) and zip it up.

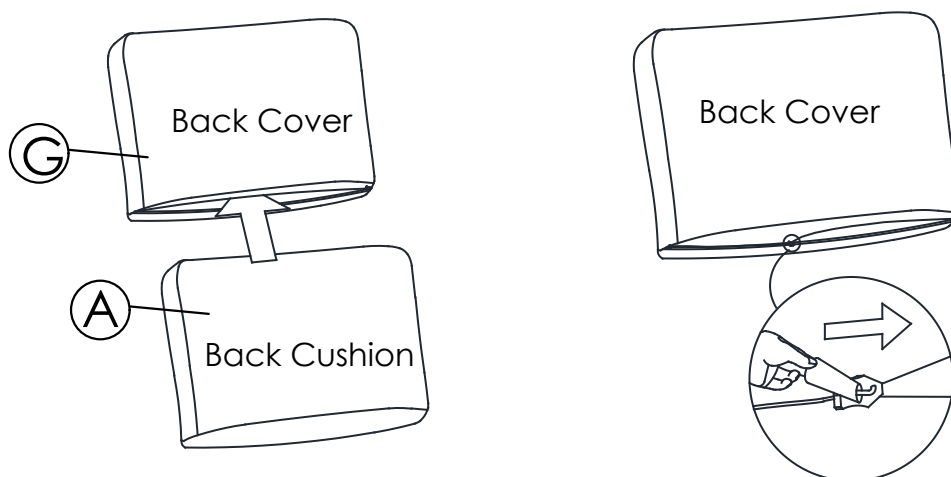

-
- 5** Please allow up to 48 hours for the Seat Cushion to return to the original thickness. For Seat Cushion (B), fluff the cushion as indicated below to help it return to the original thickness.

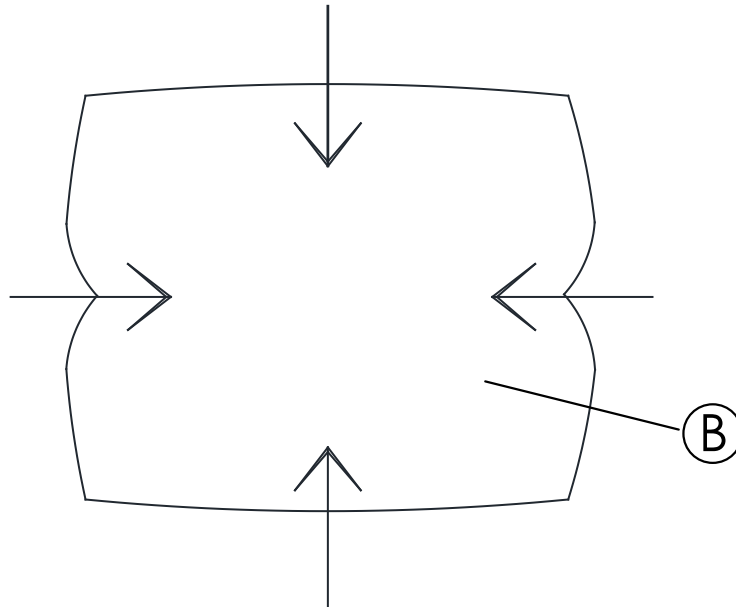

- 6** Detach the Velcro at the front of the Seat (C).

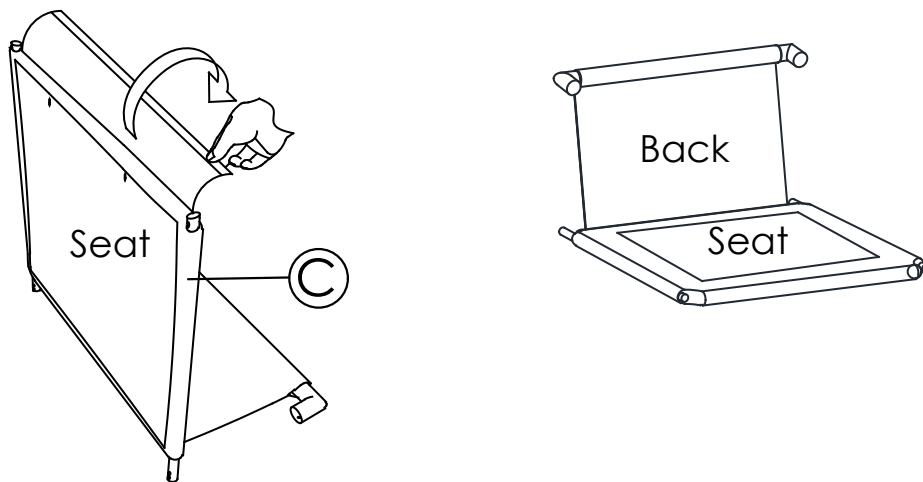

- 7** Insert Front Leg (F) into Seat (C). Please insert both sides at the same time and apply some pressure. Attach both sides of Front Leg (F) to Seat (C), using Bolts (I) and Allen Wrench (O). Fully tighten.

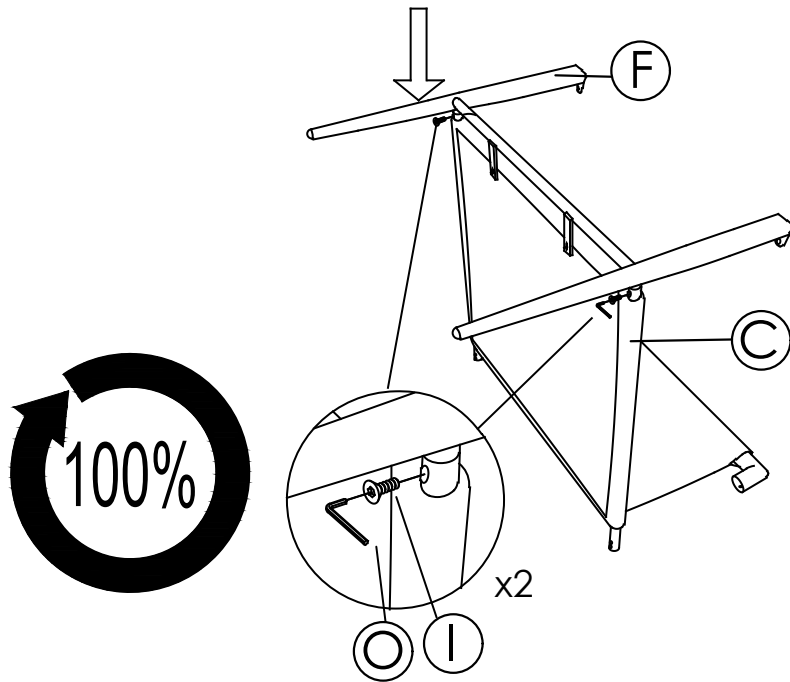

- 8** Attach the square metal plates on Front Leg (F) to Seat (C), using Bolts (K), Lock Washers (N), Flat Washers (M) and Allen Wrench (O). Fully tighten.

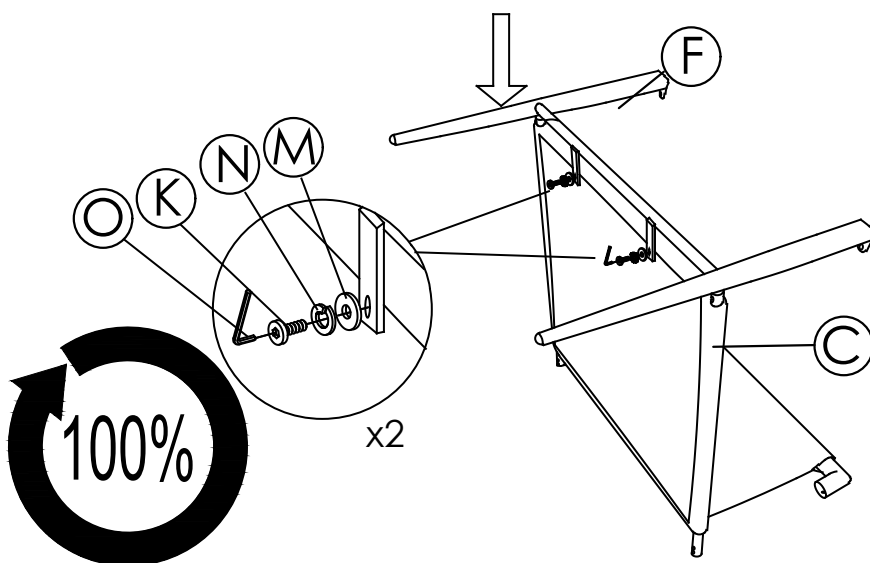

- 9 Attach the Velcro as shown below.

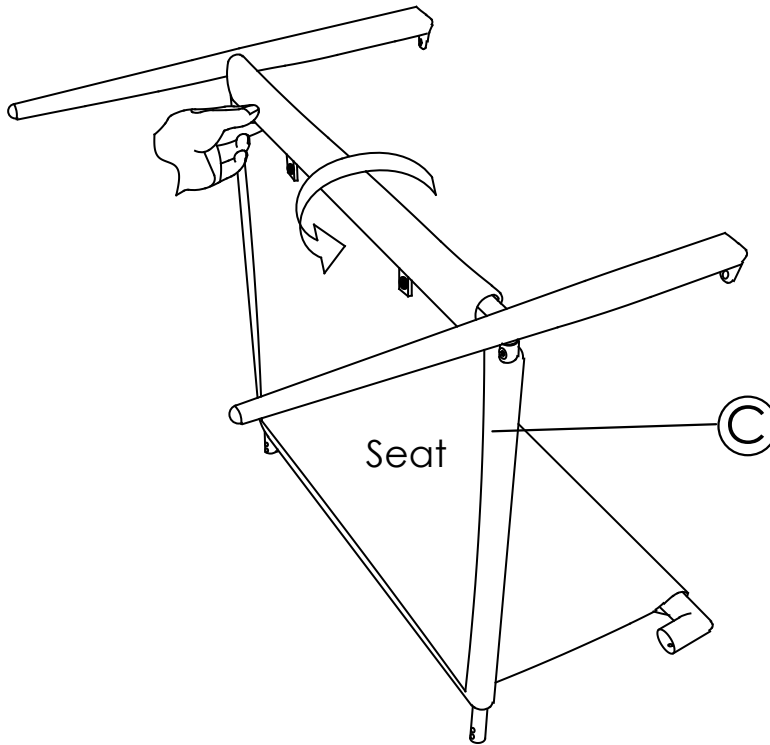

- 10 Attach Left Back Leg (L) and Right Back Leg (R) to Seat (C), using Bolts (I) and Allen Wrench (O). Do not fully tighten yet.

Note: Please make sure the arrow should face the front side of the chair. Do not fully tighten yet.

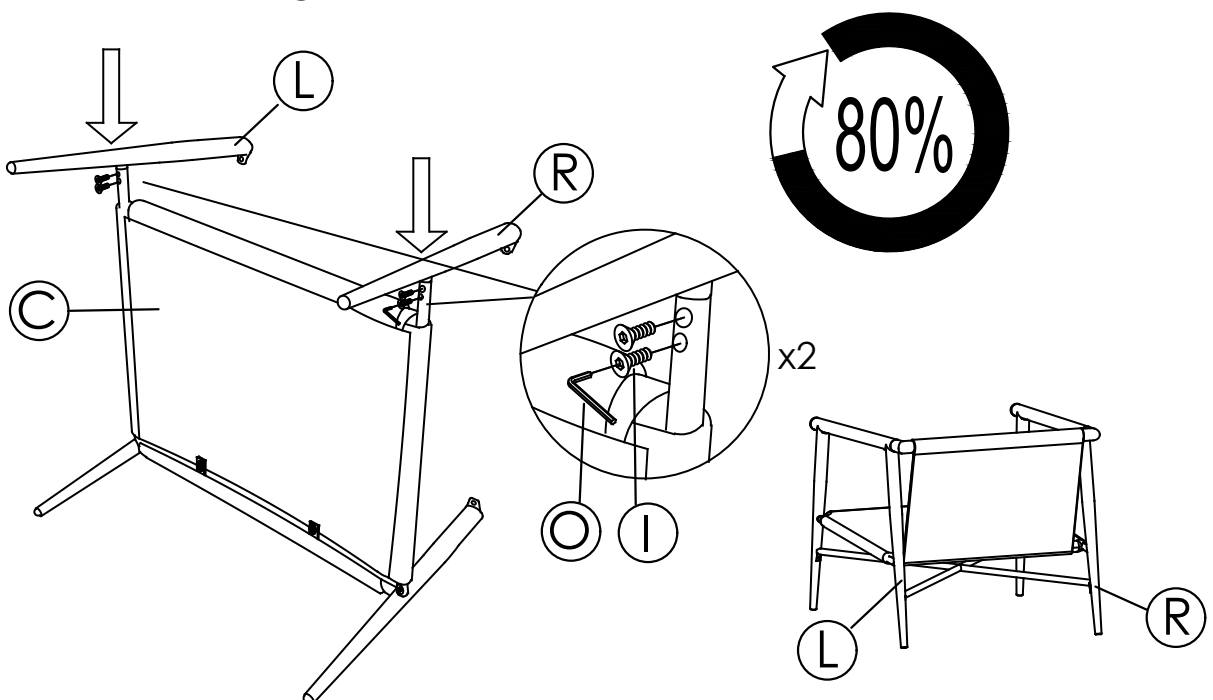

- 11** Attach X-Shaped Frame (E) to assembled chair legs, using Bolts (I) and Allen Wrench (O).

Note: Please make sure the arrow should face the front side of the chair. Do not fully tighten yet.

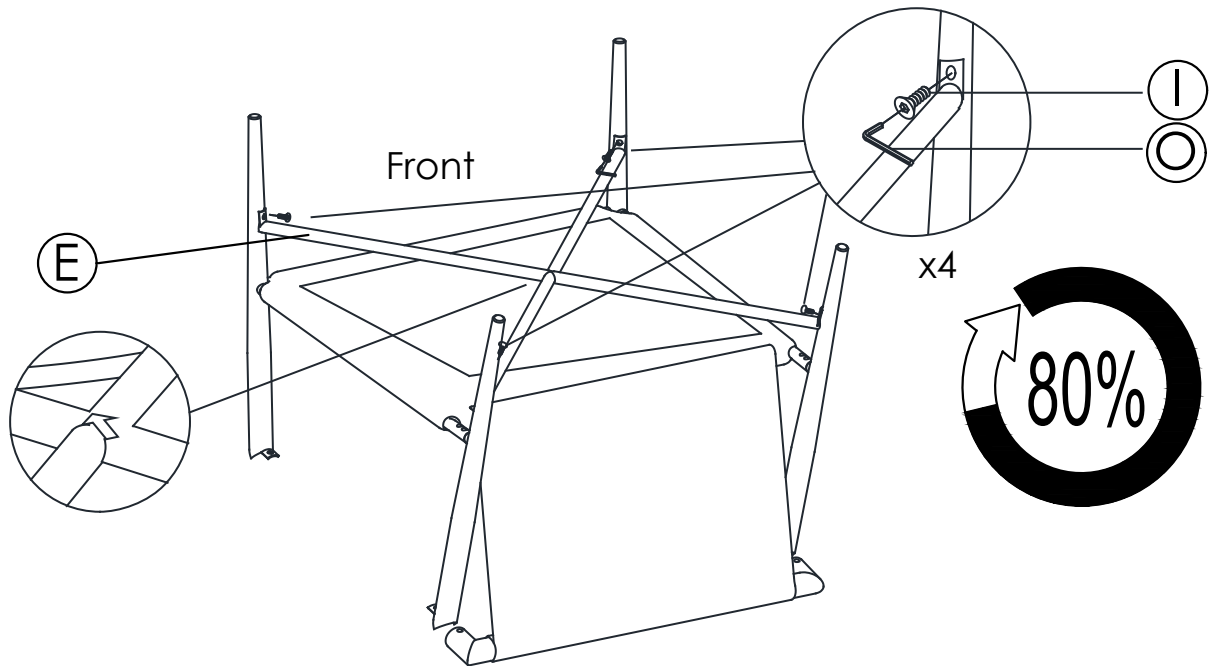

- 12** Attach Wood Arms (D) to Back (C), using Bolts (J) and Allen Wrench (O). Fully tighten.

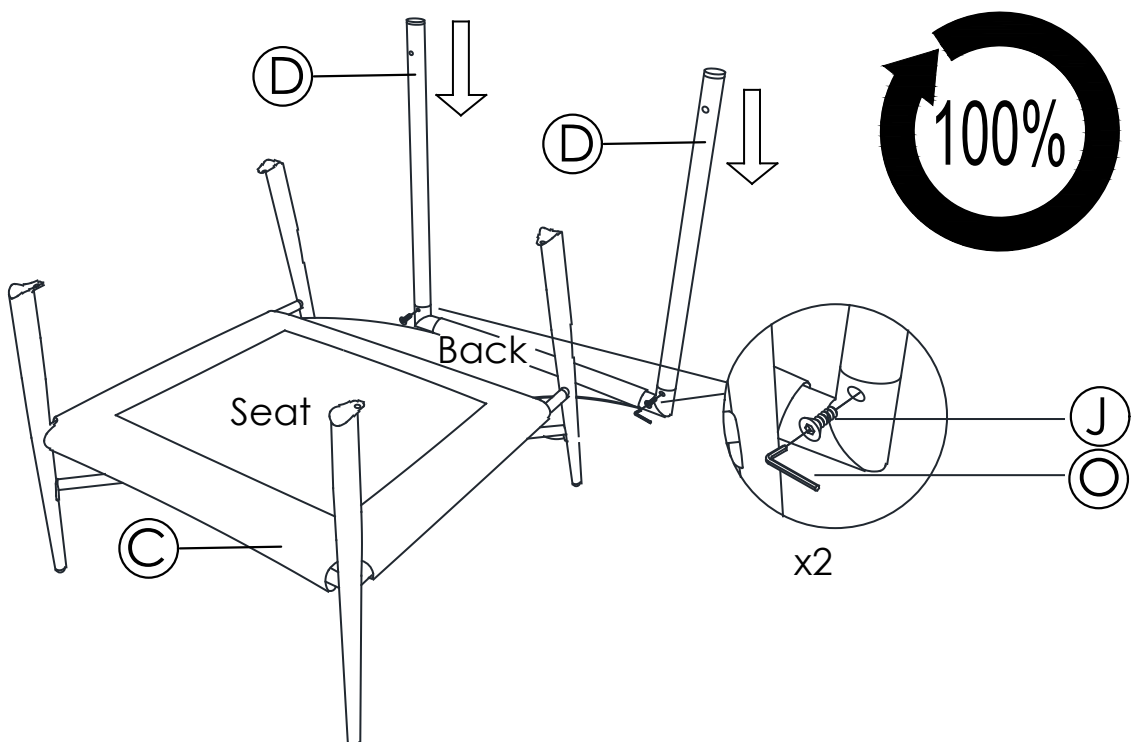

- 13** Attach Wood Arms (D) to front legs and back legs, using Bolts (J) and Allen Wrench (O). Start with bolts at the front legs and then move on to the bolts at the back legs. **Do not fully tighten yet.**

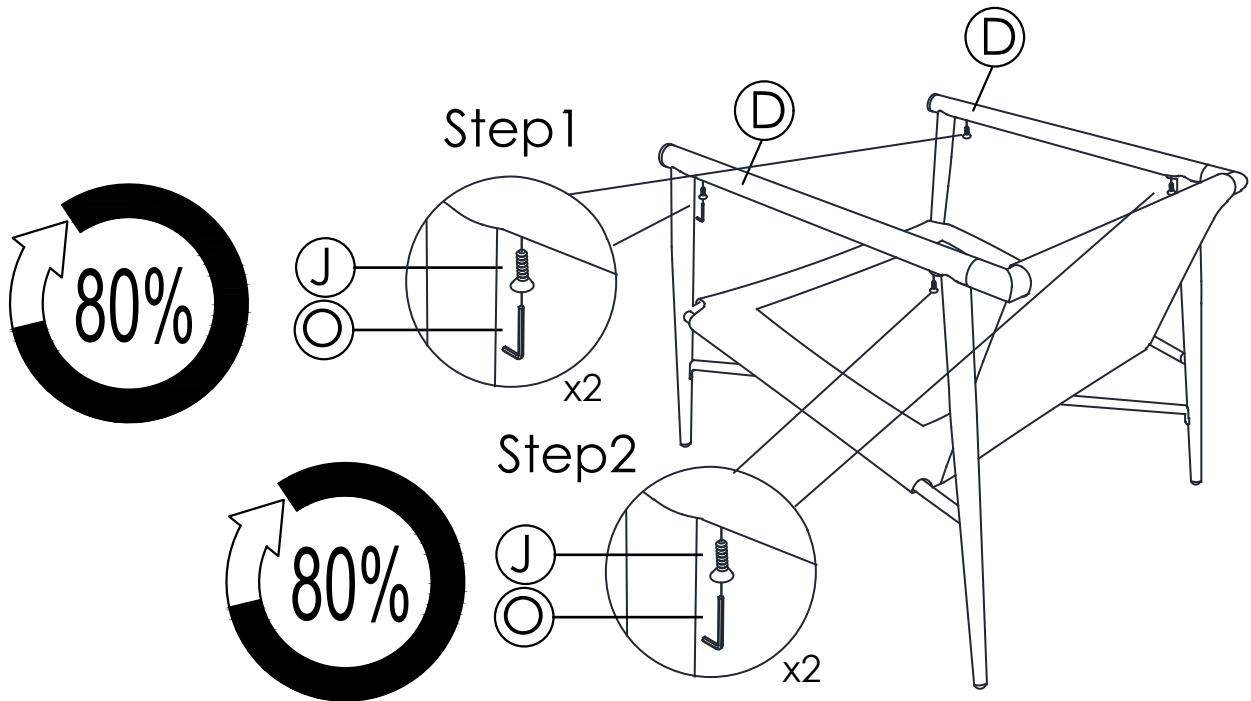

- 14** Use Allen Wrench (O) to fully tighten all bolts in Step 5, 6, and 8 (Ten bolts in total).

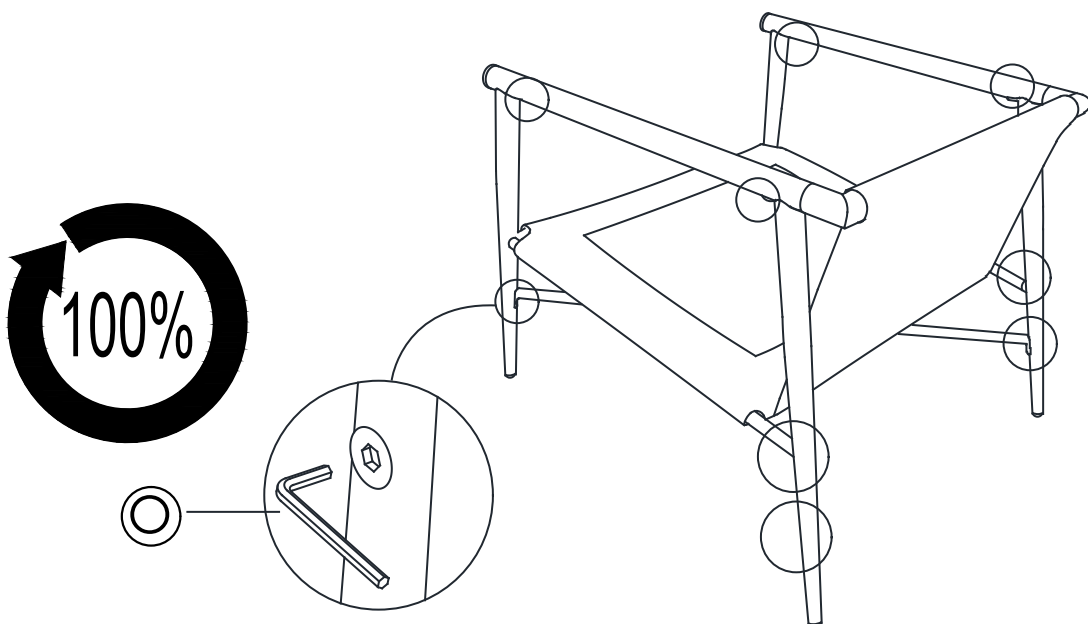

- 15** Complimentary Felt Pads (P) are included to help protect your floor or make the stool slide easier.

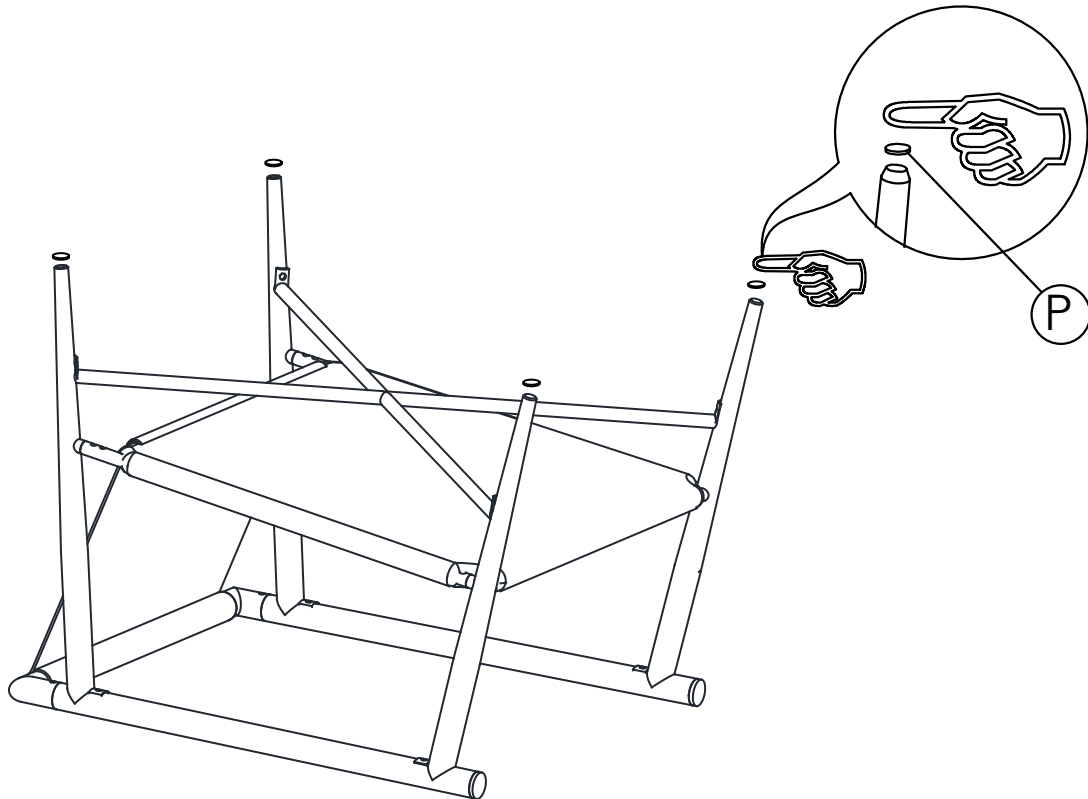

- 16** Put the assembled Seat Cushion in Step 3 and the assembled Back Cushion in Step 4 on the chair.

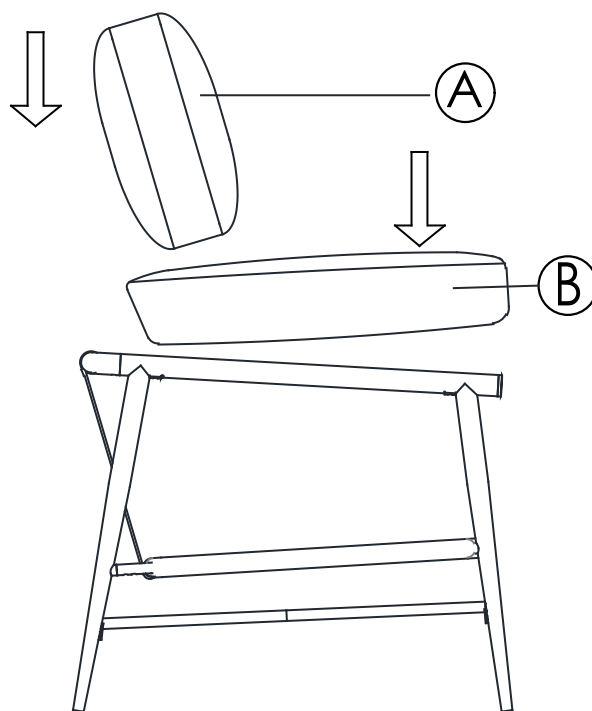

-
- 17** Turn assembled chair upright and place on a flat surface.
Note: Each leg has an adjustable foot leveler to help level your chair.

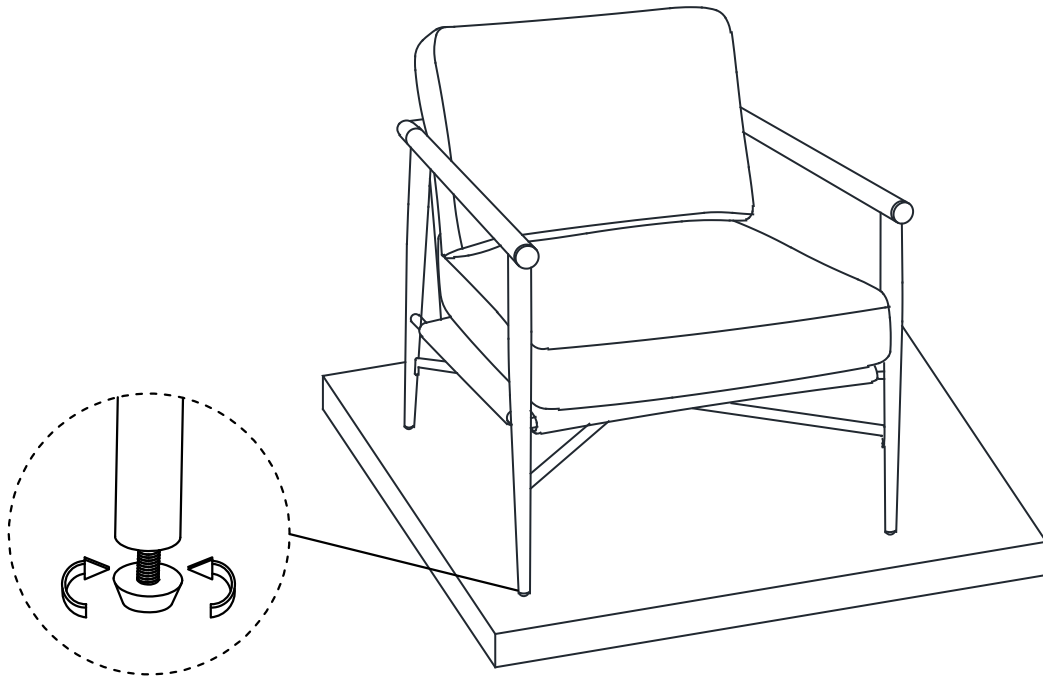

- 18** Assembly complete. Enjoy.

