







ASSEMBLY INSTRUCTIONS

Don't tighten any Bolts until all Bolts on a step have been started.

Thank you for purchasing this quality product. Be sure to check all packing material carefully for small parts, which may have come loose inside the carton during shipment. Identify and count all parts and compare with the **HARDWARE LIST** below.

NO.	PARTS LIST	
A		Table Top
B		Leg
C		Bottom Stretcher
D		Upper Stretcher

Q' TY
1
4
1
1

NO.	PARTS LIST		Q' TY
1		Ø 1/4" X 5/8" Bolt	8
2		Ø 1/4" X 5/8" Bolt	8
3		Allen Wrench 4mm	1

Q' TY
8
8
1

STEP 1

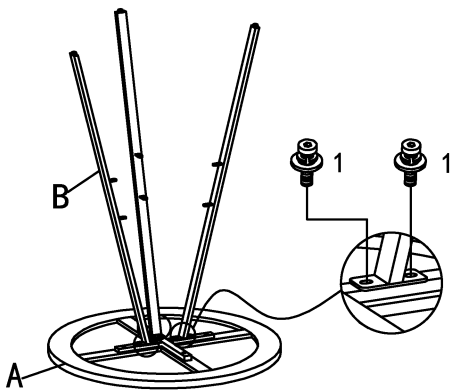

1. Up side down the Table Top (A) on a clean working stand.
2. Attach three Legs (B) to the Table Top (A), using Bolts (1) and Allen Wrench (3) to tighten, as shown

STEP 2

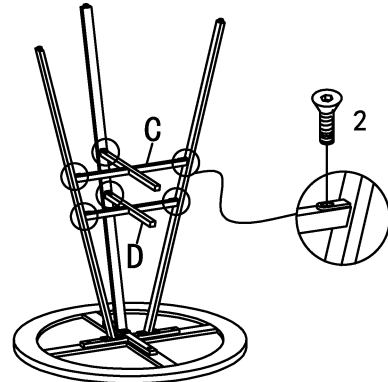

1. Attach the Bottom Stretcher (C) and Upper Stretcher (D) to the three Legs (B), using Bolts (2) and Allen Wrench (3) to tighten.

STEP 3

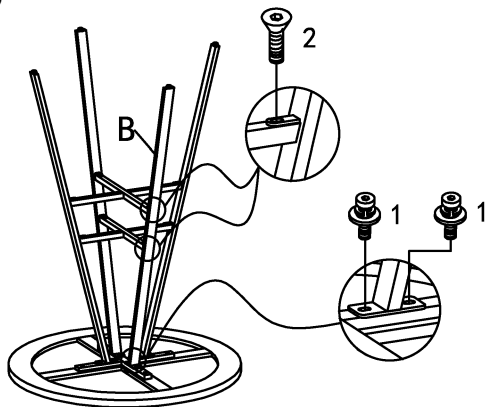

1. Attach the 4th Leg (B) to the Table Top (A) and the Stretchers (C & D), using Bolts (1) & (2) and Allen Wrench (3) to tighten.

STEP 4

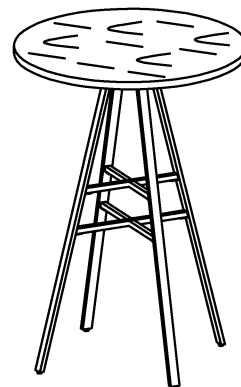

1. Flip the Table right side up.
2. You have finished assembling your product.

Caution: 1. All bolts must be tightened mandatorily in each step.
2. It is also mandatorily recommended to periodically check bolts and retighten as needed.