

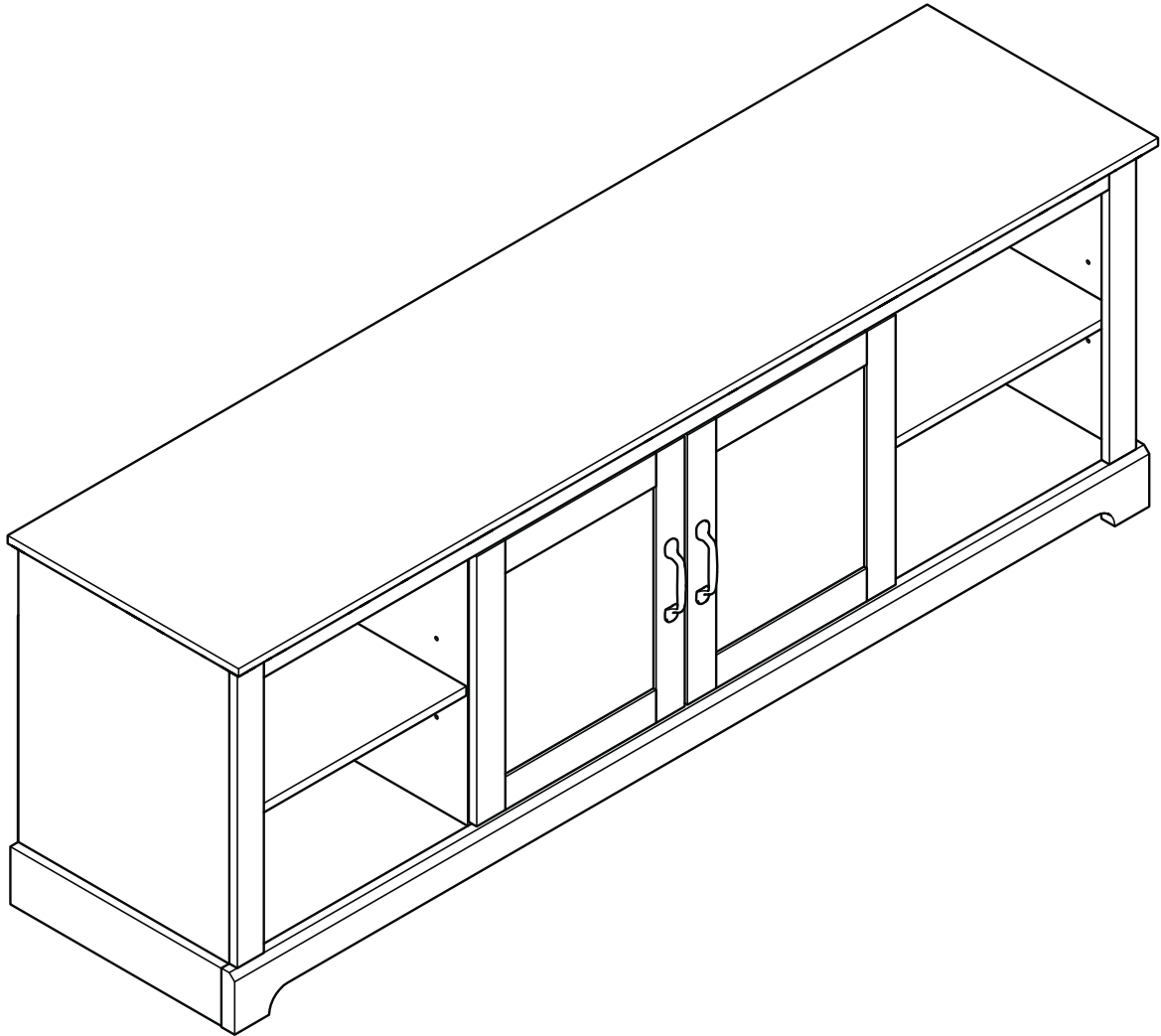





**ASSEMBLY INSTRUCTIONS / INSTRUCTIONS
D'ASSEMBLAGE / INSTRUCTIVO DE ARMADO**



NOTES ON ASSEMBLY / NOTES POUR L'ASSEMBLAGE / NOTAS SOBRE EL ENSAMBLE

- To ensure ease of assembly read all instructions before assembly and follow step by step illustrations.
- Keep instructions for future use.
- Adult assembly required.  2 person required. 
- Due to the presence of small parts during assembly, keep out of reach of children until assembly is complete.

- Pour assurer l'assemblage facile veuillez lire toutes les instructions avant l'assemblage et veuillez suivre les illustrations pour chaque étapes.
- Veuillez garder ces instructions pour l'usage ulterieur.
- Assemblage requis pas un adulte.  2 personnes requises. 
- Due a la presence de petite pieces durant l'assemblage, veuillez garder hors de porter des enfants jusqu'a ce que l'assemblage soit completer.

- Para garantizar la facilidad de ensamble lea las instrucciones antes de iniciar y siga paso a paso las ilustraciones.
- Guarde las instrucciones para futuras referencias.
- El ensamble requiere de un adulto.  2 personas requeridas. 
- Debido a que hay piezas pequeñas, mantenga fuera del alcance a los niños durante el ensamble, hasta que haya terminado.

MAINTENANCE TIPS / CONSEILS D'ENTRETIEN / CONSEJOS DE MANUTENIMIENTO

- Never let liquids or damp cloths sit on this furniture.
- Never use chemical cleaning products. They can damage the finish. For cleaning, use only a slightly damp cloth and wipe dry.
- To avoid dulling of the finish, do not place furniture in direct sunlight.
- Do not put plastic or rubber rings under appliances. Use cloth of felt protectors.
- To clean, use a soft or slightly damp cloth, then wipe with a clean, dry cloth.

- Ne jamais laisser de liquide ou linge humide sur le meuble.
- Ne jamais utiliser de nettoyeurs à base de produits chimiques, cela va endommager le fini. Utiliser seulement un linge légèrement humide.
- Ne pas placer le meuble directement au soleil pour prévenir le ternissement.
- Évitez de déposer des appareils avec des rondelles de plastique ou de caoutchouc. Utilisez un protecteur en tissu ou en feutre.
- Pour nettoyer, utilisez un linge doux ou légèrement humecté. Essuyez par la suite avec un linge propre et sec.

- Nunca deje un líquido o un trapo húmedo sobre el mueble.
- Nunca utilice limpiadores a base de químicos, estos dañaran le acabado. Use sólo un paño húmedo.
- No esponga el mueble directamente al sol para prevenir empañamiento.
- Evite apoyar aparatos con redondeles de plástico o de goma. Utilizar un protector de tela o de fieltro.
- Para limpiar, utilice un trapo suave o ligeramente humedecido. Seque luego con un trapo limpio y seco.

WARNING AVERTISSEMENT / ADVERTENCIA

Please use your furniture correctly and safely. Improper use can cause safety hazards, or damage to your furniture or household items.

Serious or fatal crushing injuries can occur from furniture tip-over.

To help prevent tip-over:

- It is important to place the safety bracket included.
- Place heaviest items in the lowest storage space.
- Never allow children to climb or hang on drawers, doors, or shelves.
- Never open more than one drawer at a time.
- If a heavy object is placed on top or inside the furniture, consider this risk.

Use of tip-over restraints reduce, but does not eliminate, the risk of tip-over.

Prière d'utiliser le mobilier à bon escient et avec prudence. Une mauvaise utilisation peut être à l'origine de risques d'accident ou peut endommager le mobilier et les articles ménagers.

Des blessures graves ou fatales peuvent résulter de basculement du meuble.

Afin de prévenir le basculement :

- Il est important d'installer le crochet de sécurité inclus.
- Placer les items les plus lourds dans les espaces de rangement du bas.
- Ne jamais laisser un enfant grimper sur les tiroirs, les portes et les tablettes ou s'accrocher à ceux-ci.
- Ne jamais ouvrir plus d'un tiroir à la fois.
- Si un objet lourd est placé sur l'unité ou à l'intérieur, considérez le risque de basculement.

L'utilisation de dispositif antibasculement ne peut que réduire les risques de basculement, sans les éliminer

Por favor use el mobiliario correcta y seguramente. El mal uso puede causar riesgos de seguridad o daño a las unidades o artículos domésticos.

El vuelco del mueble puede ser causa de lesiones graves o de un aplastamiento fatal.

Para evitar la volcadura:

- Es importante instalar el gancho de seguridad.
- Ponga las cosas pesadas en los compartimentos más bajos.
- Nunca permita que un niño se suba o se cuelgue en cajones, puertas o estantes.
- Nunca abra más de un cajón a la vez.
- Si un objeto pesado esta colocado dentro o sobre el mueble, considere el riesgo de que se puede voltear.

El uso de sujetadores para evitar el vuelco sólo puede disminuir el riesgo de un vuelco, pero no lo elimina.

THINGS TO REMEMBER FOR ASSEMBLY
CHOSSES À SE SOUVENIR POUR UNE ASSEMBLEE
COSAS PARA RECORDAR EN UNA ASAMBLEA

MINIFIX BOLT
BOULON MINIFIX
PERNO MINIFIX

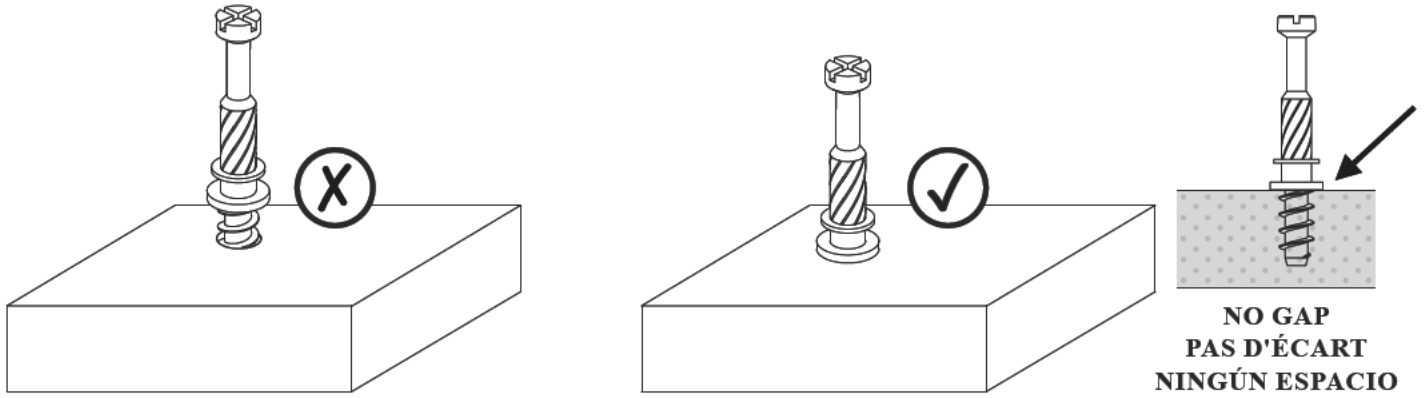

MINIFIX CAM
CAMÉRA MINIFIX
CÁMARA MINIFIX

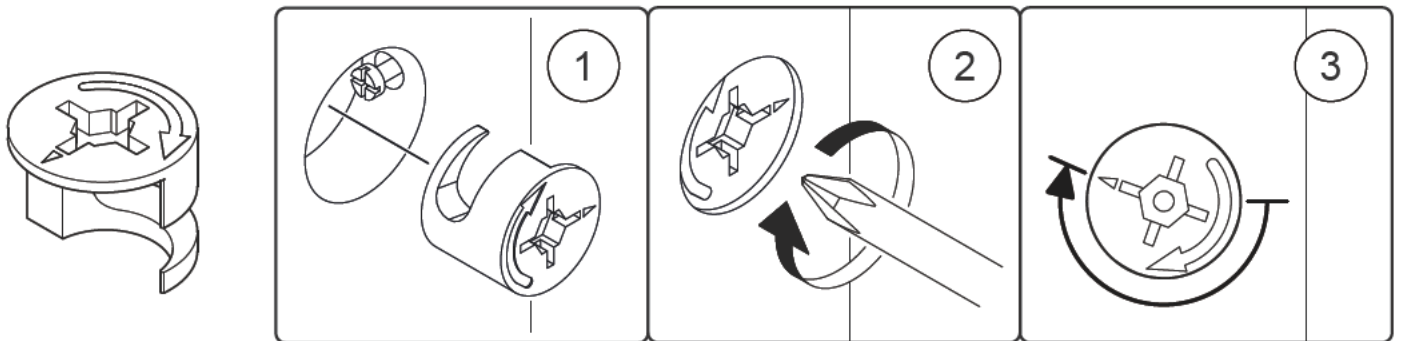



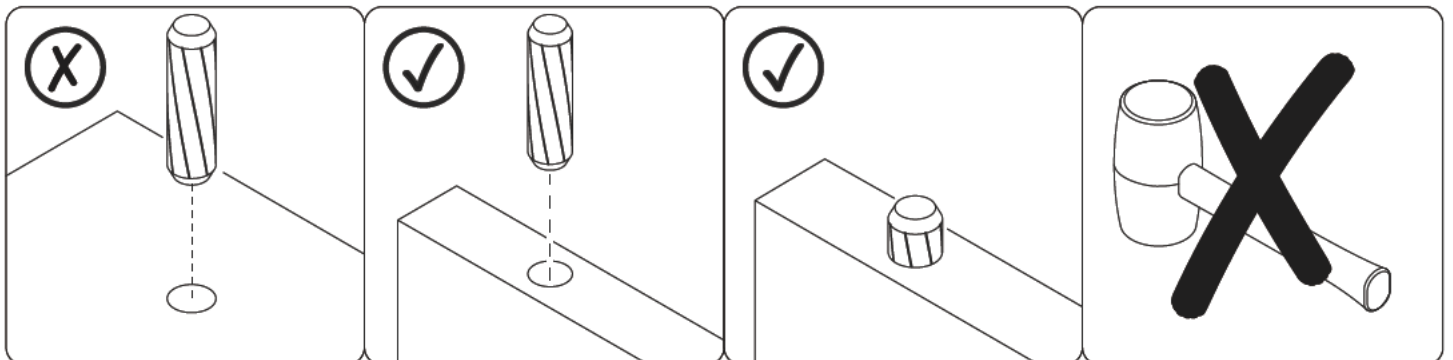

WOOD DOWEL
CHEVILLE BOIS
PASADOR DE MADERA

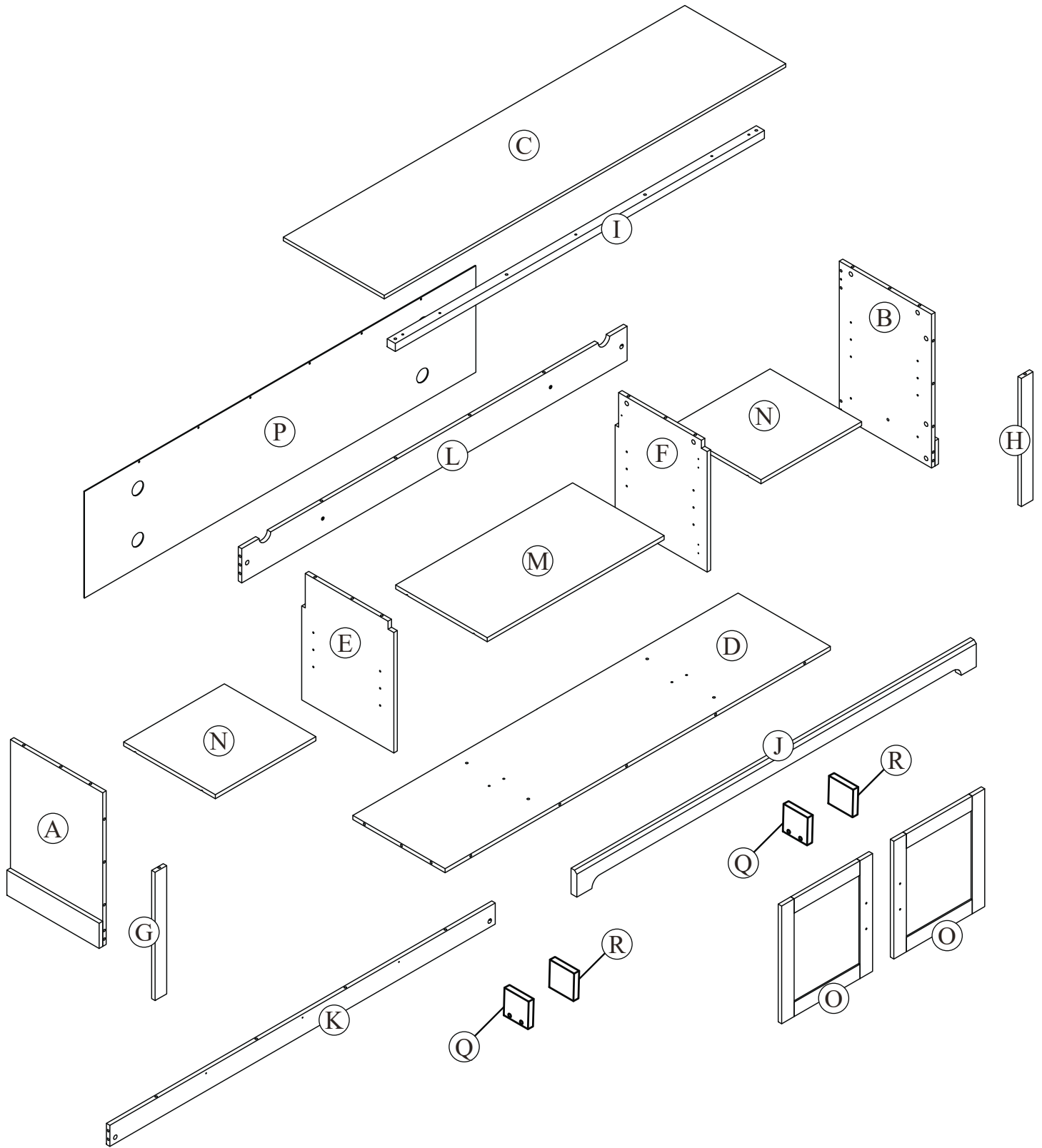

PARTS IDENTIFICATION
IDENTIFICATION DES PIÈCES
IDENTIFICACIÓN DE LAS PARTES



HARDWARE QUINCAILLERIE / HERRAJE

| | | | | | |
|-----|---|-----|---|-----|--|
| (A) | Minifix Bolt EU 24  25 units | (B) | Minifix Cam 15/9.5  25 units | (C) | Dowel M8 x 30mm  34 + 2 units |
| (D) | Screw M4 x 19mm  4 units | (E) | Unita M6.3 x 40mm  4 units | (F) | Screw M3.5 x 15mm  22 + 2 units |
| (G) | Nail Pin 3/4"  16 units | (H) | Dav Handle 96mm  2 units | (I) | Allen Key Z (M4)  1 unit |
| (J) | PVC L Bracket  8 units | (K) | Door Stopper  2 units | (L) | Hinges (Outside 5/8")  4 units |
| (M) | Shelf Support  12 units | (N) | Screw M4 x 45mm  5 units | (O) | Screw #10 x 1/2"  16 + 2 units |
| (P) | Nail Leg  4 units | (Q) | Unita M6.3 x 50mm  8 units | | |





- Hardware quantity may supplied more than it required. Please keep spares and tools for future use.
- La cantidad de hardware puede suministrarse más de lo requerido. Guarde los repuestos y las herramientas para uso futuro.
- La quantité de matériel peut fournir plus que nécessaire. Veuillez conserver les pièces de rechange et les outils pour une utilisation future.

FURNITURE TIPPING RESTRAINT

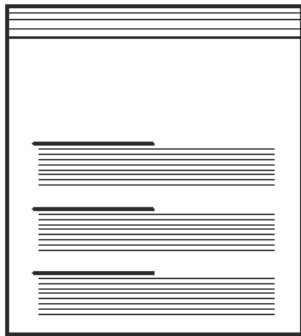
SEGURO CONTRA VOLCADO DE MUEBLES

DISPOSITIF DÉ SÉCURITÉ POUR MEUBLES





| | | | |
|------|---|------|---|
| (AA) | Mounting L Bracket  | (BB) | Washer M6 x 16mm  |
| | 2 units | | 2 units |
| (CC) | Screw #10 x 16mm  | (DD) | Screw M4 x 38mm  |
| | 2 units | | 2 units |

TOOLS NOT INCLUDED

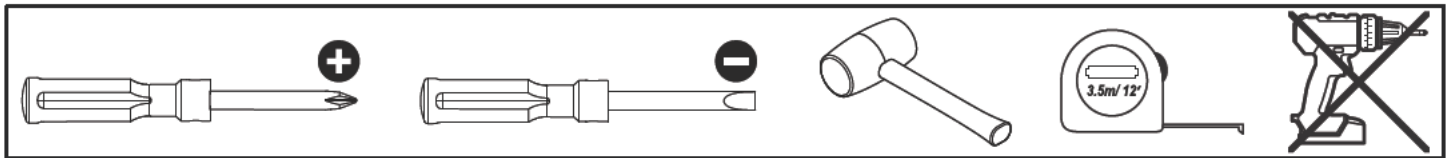
OUTILS PAS INCLUS / HERRAMIENTAS NO INCLUIDAS



STEP 1

| | | |
|---|---|---|
|  |  |  |
| C x 10 | F x 3 | J x 3 |

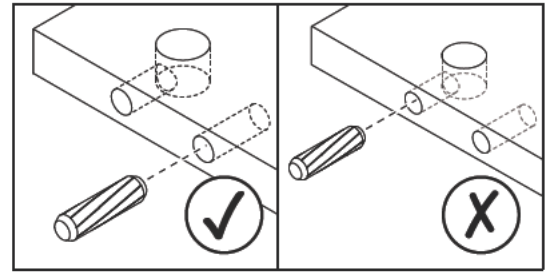
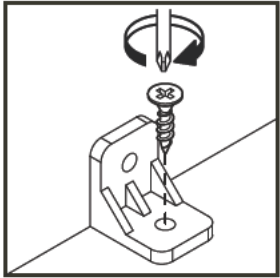
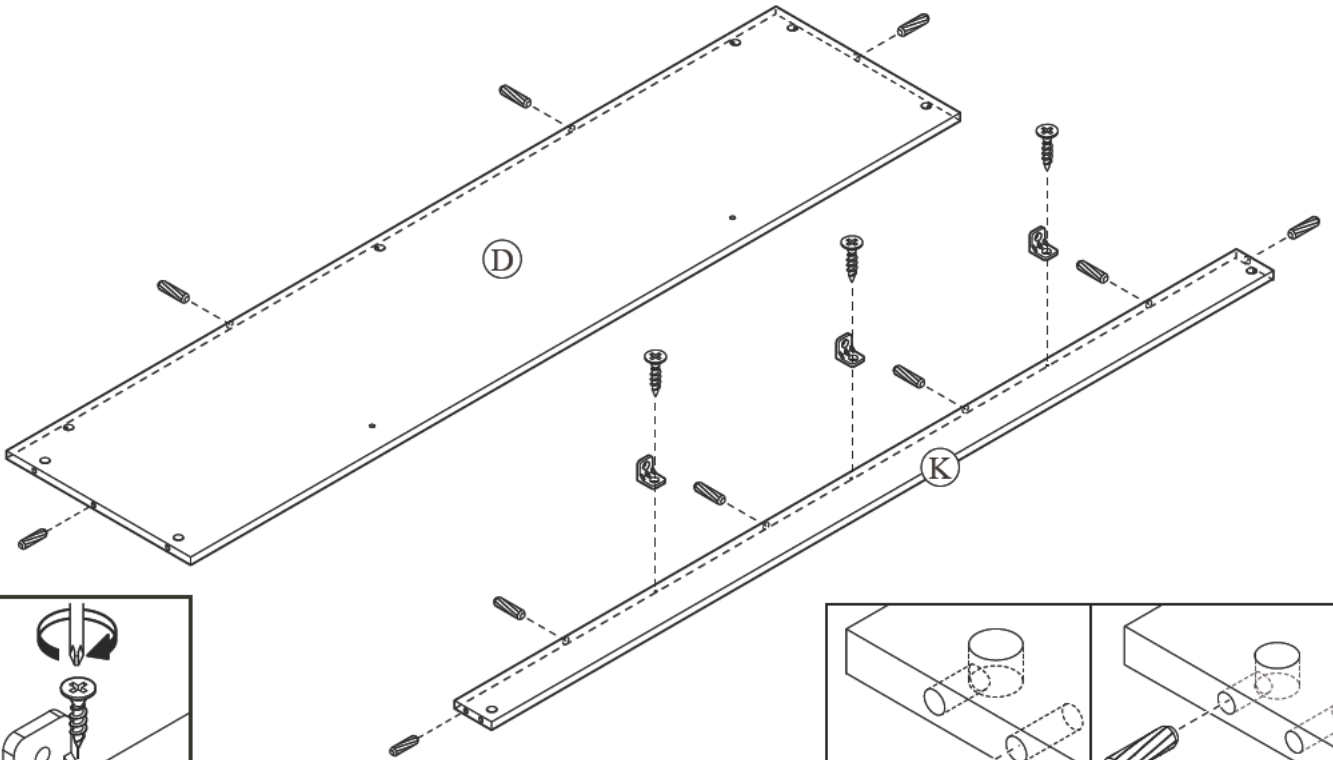

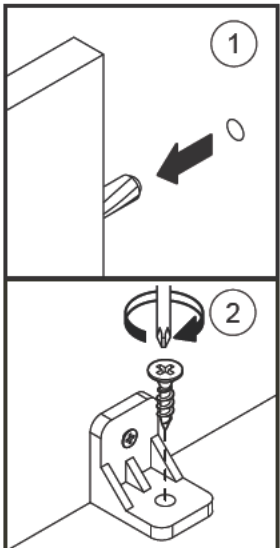
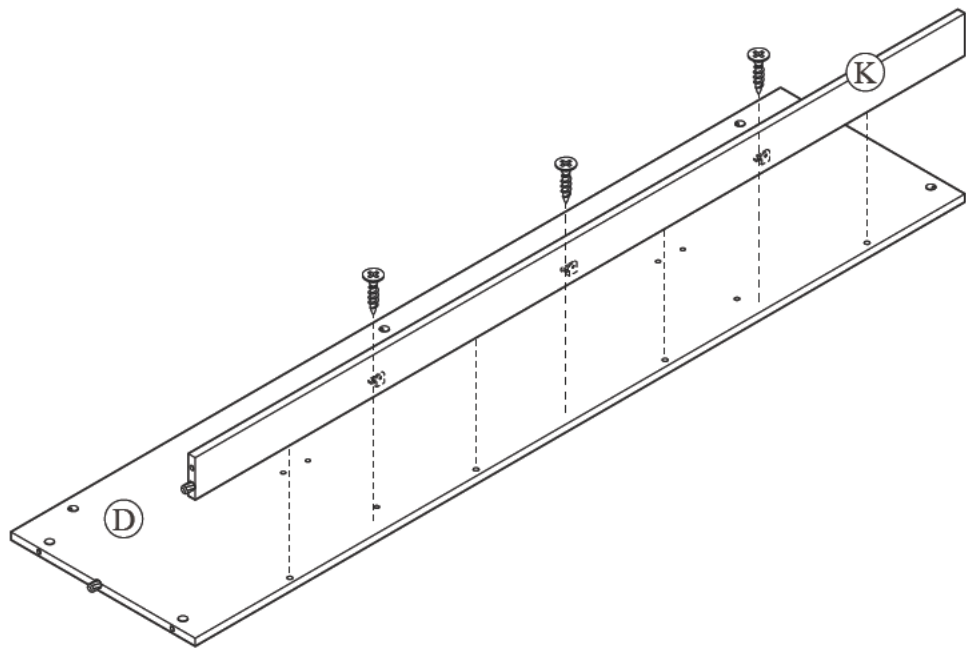

STEP 2

| |
|---|
|  |
| F x 3 |



STEP 3

| | |
|---|---|
|  |  |
| C x 4 | A x 6 |

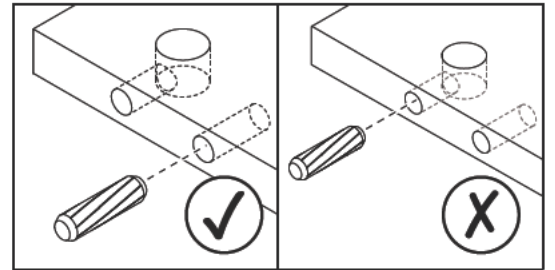
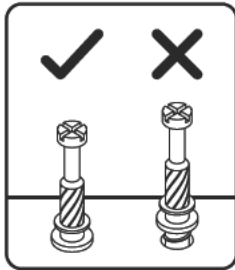
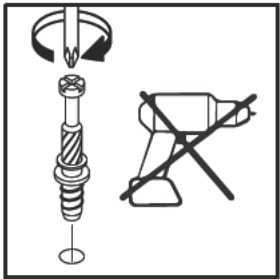
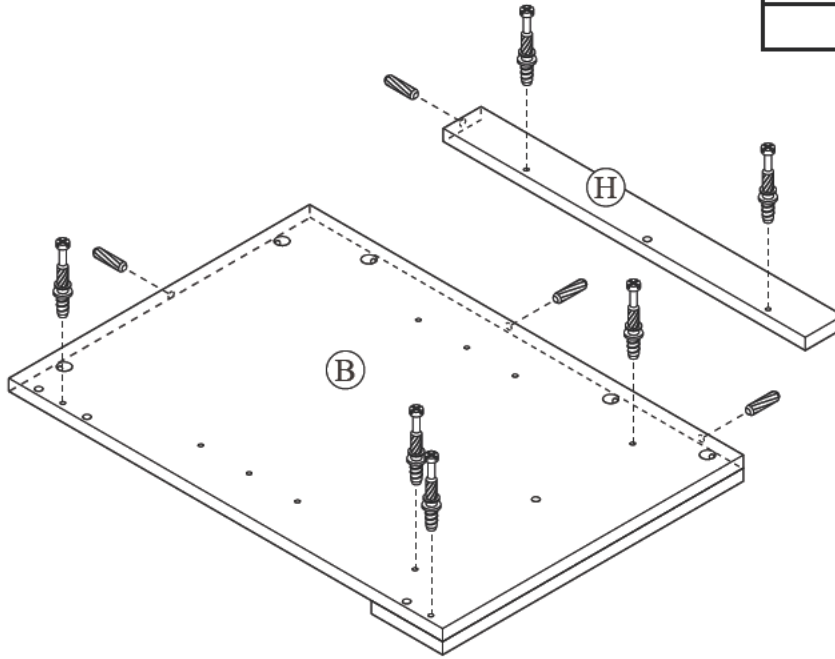

STEP 4

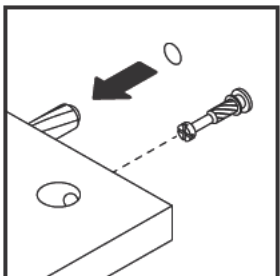
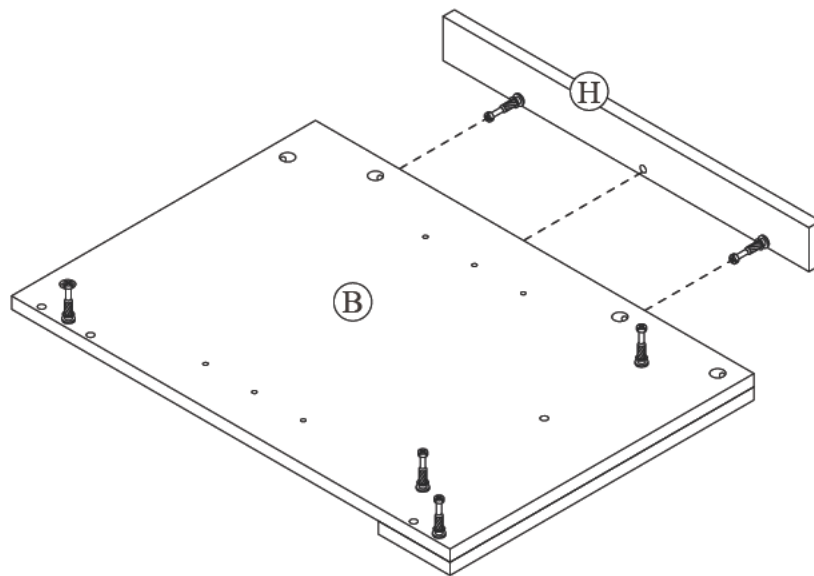

STEP 5

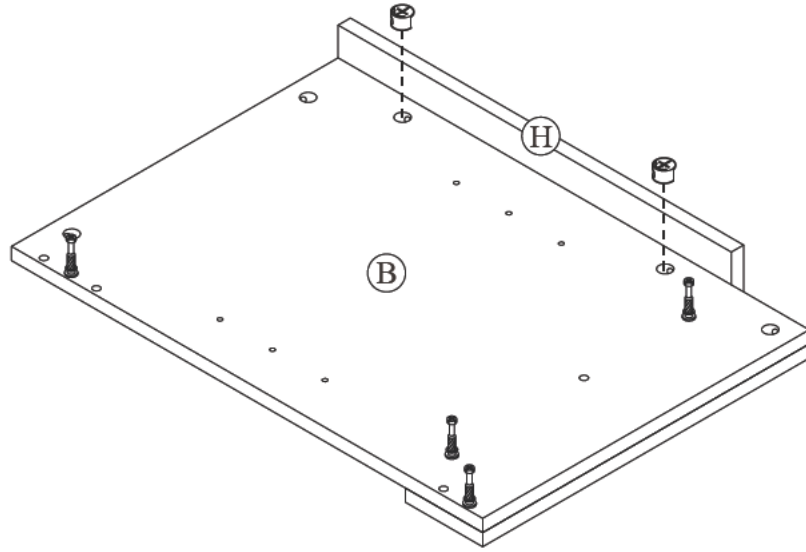
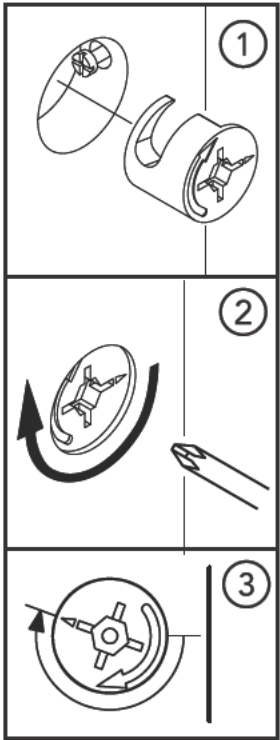

STEP 6

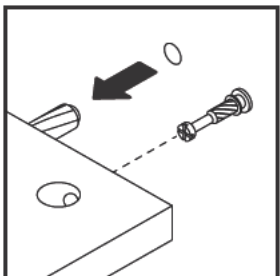
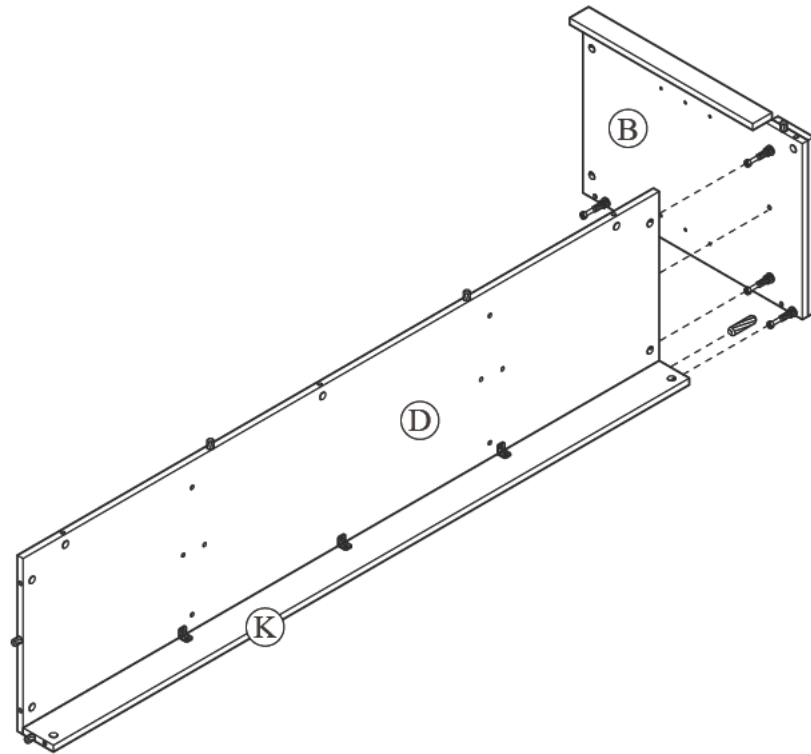

STEP 7

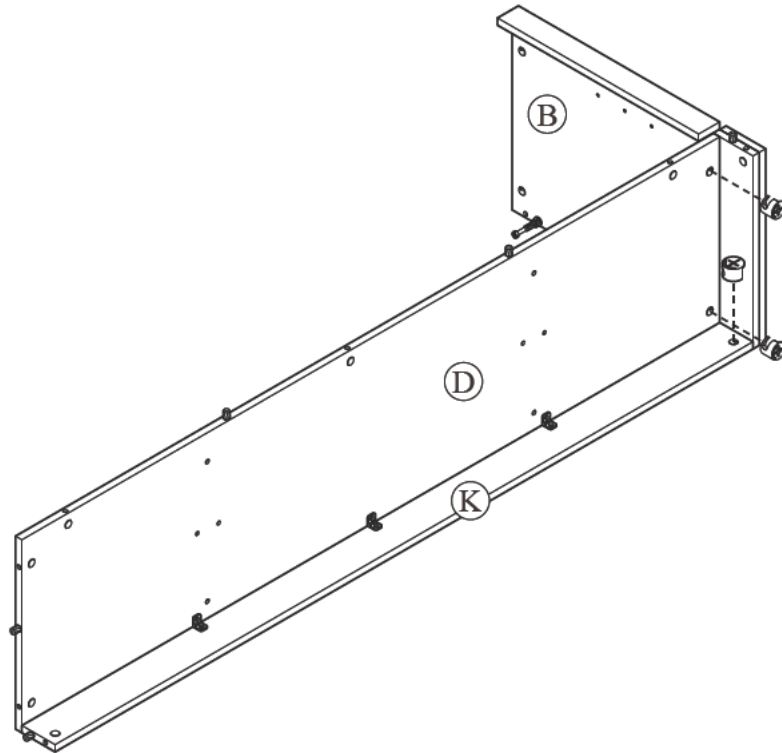
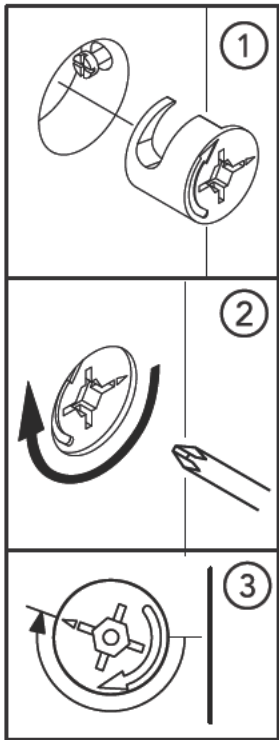

STEP 8

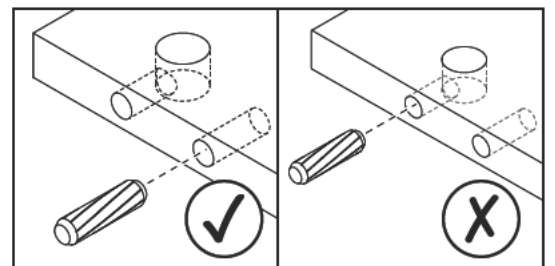
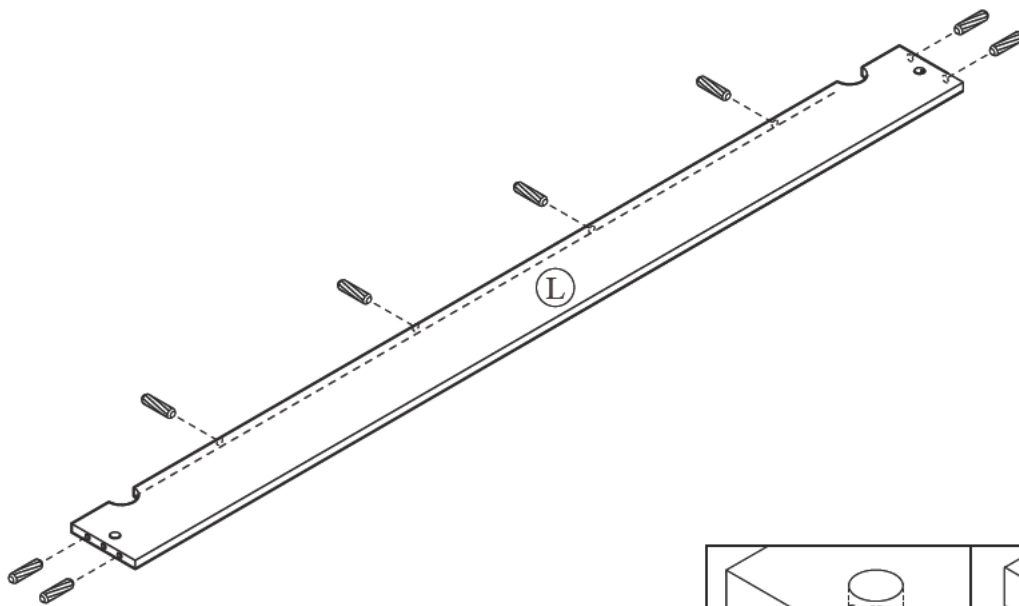
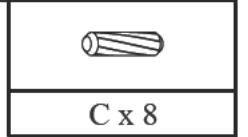

STEP 9

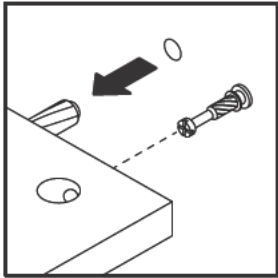
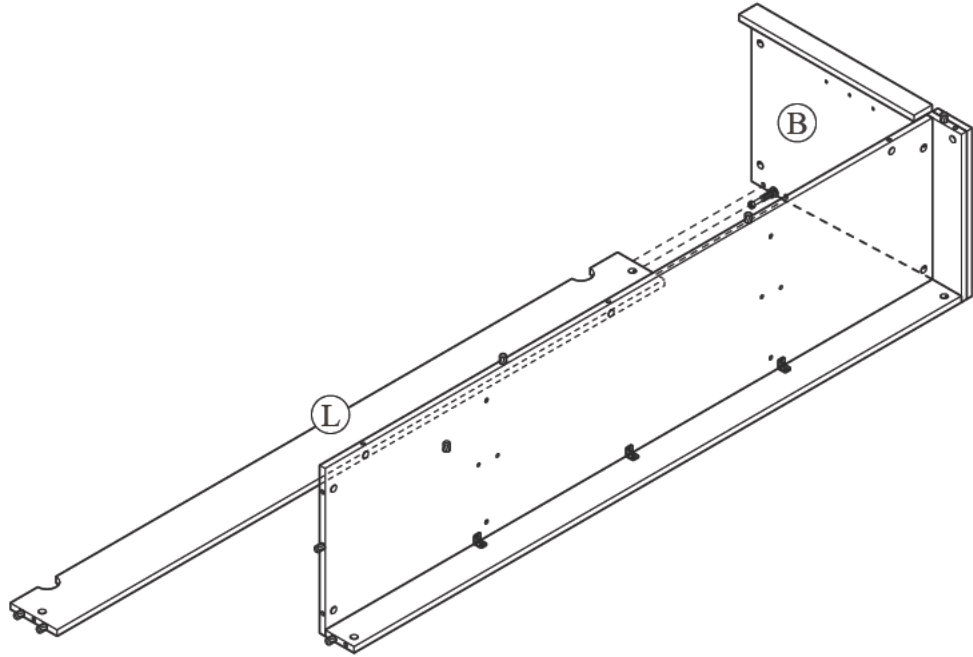

STEP 10

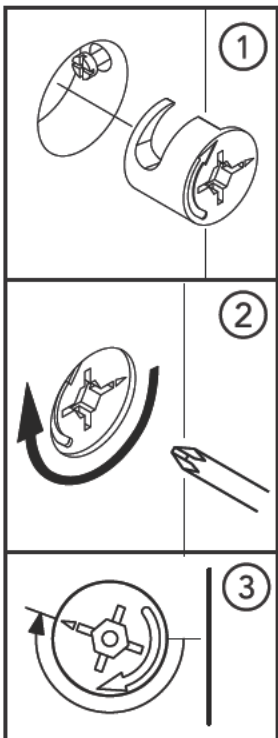
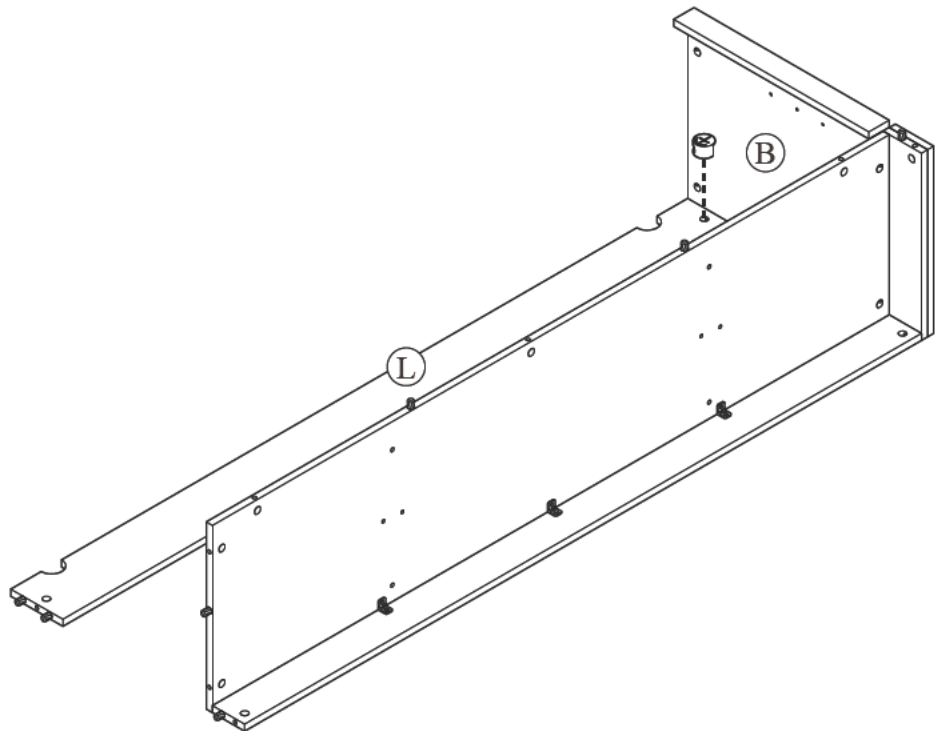

STEP 11

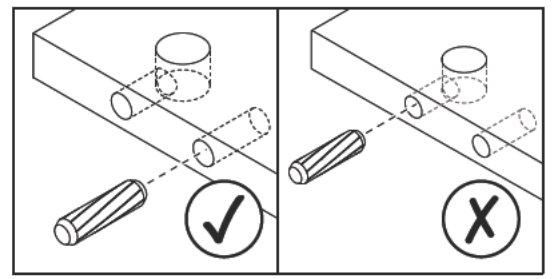
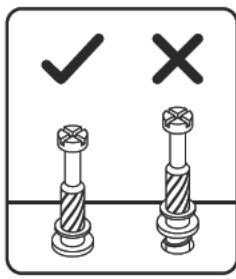
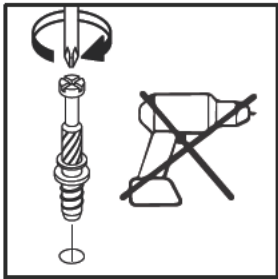
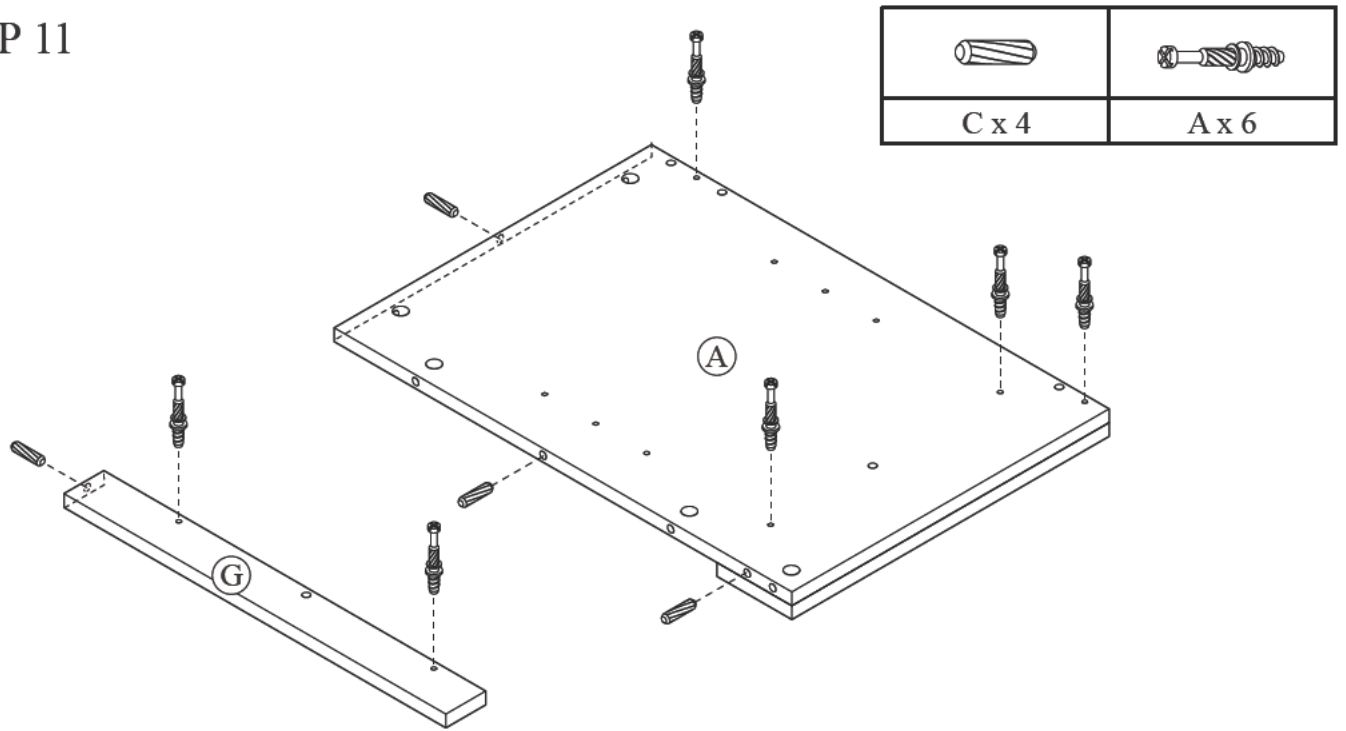

STEP 12

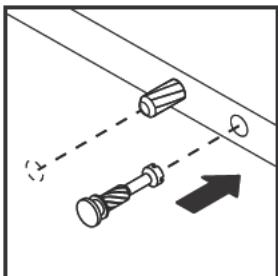
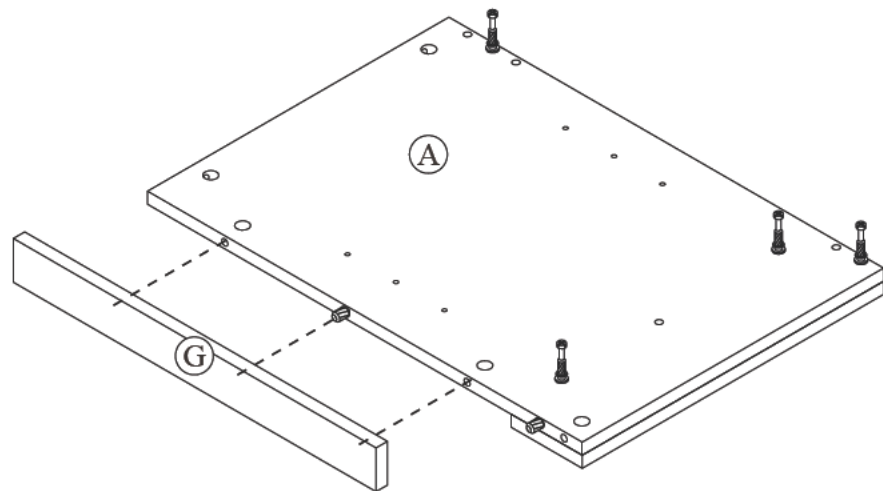

STEP 13

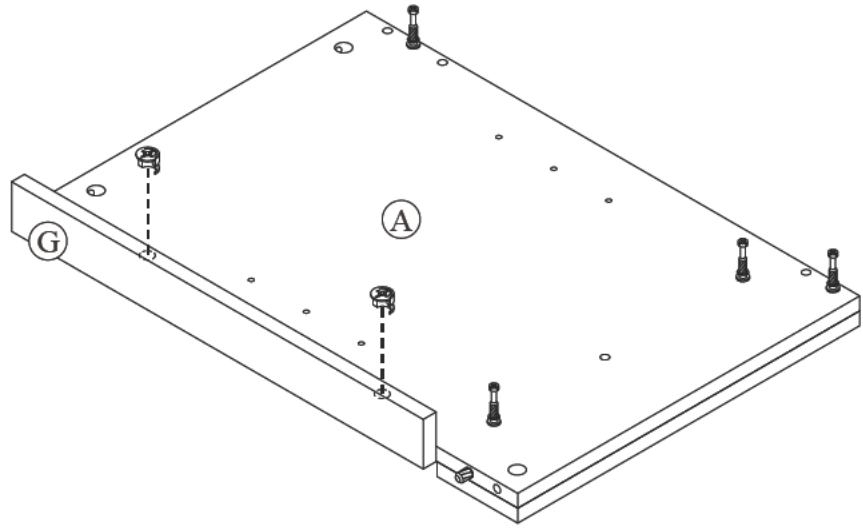
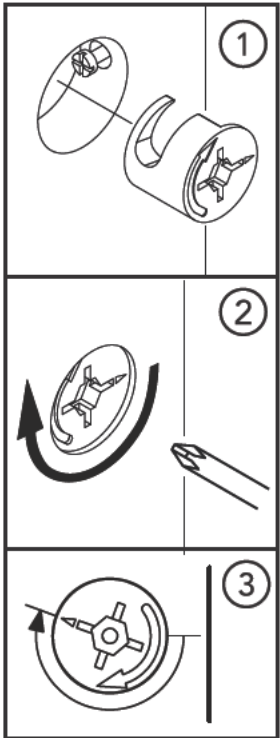

STEP 14

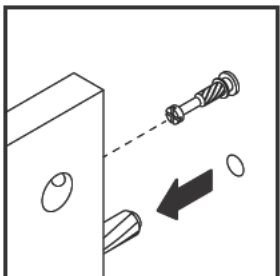
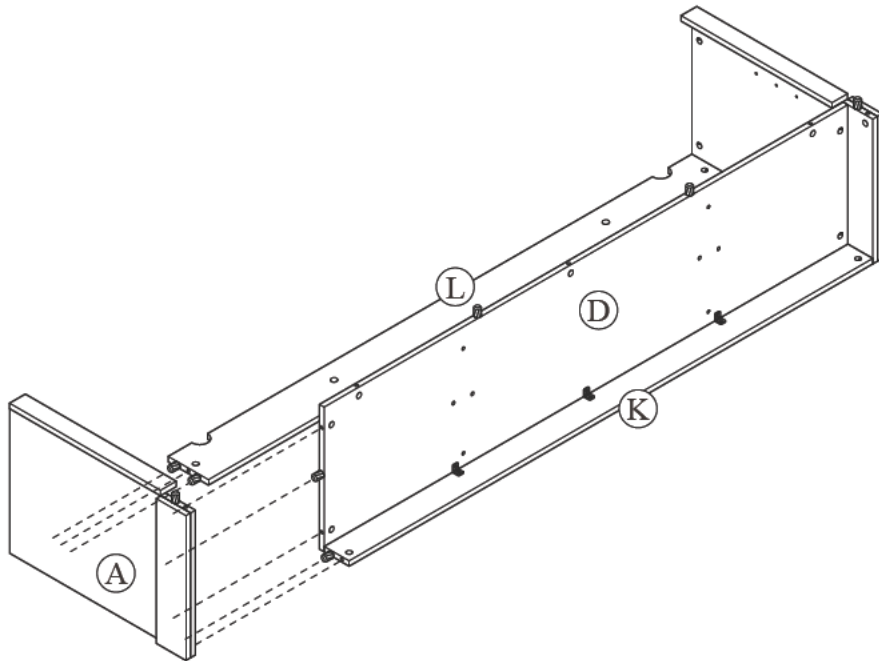

STEP 15



B x 4

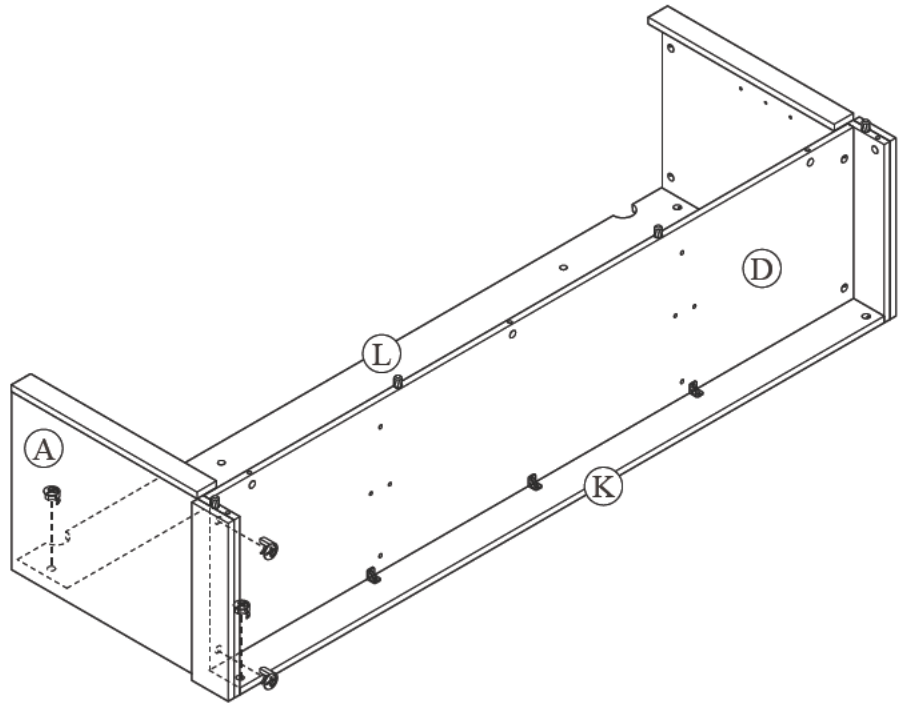
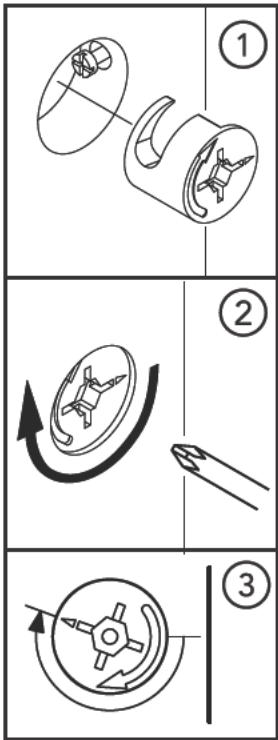

STEP 16

| | | |
|-------|-------|-------|
| | | |
| C x 4 | F x 2 | J x 2 |

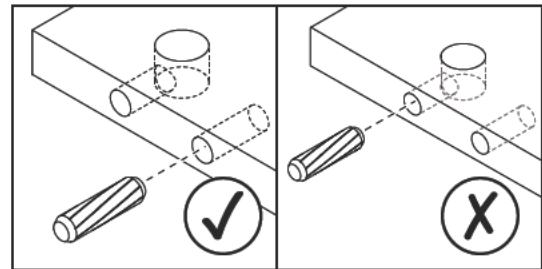
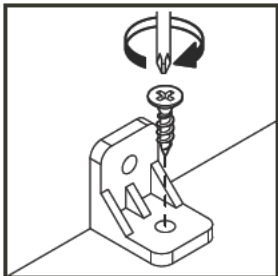
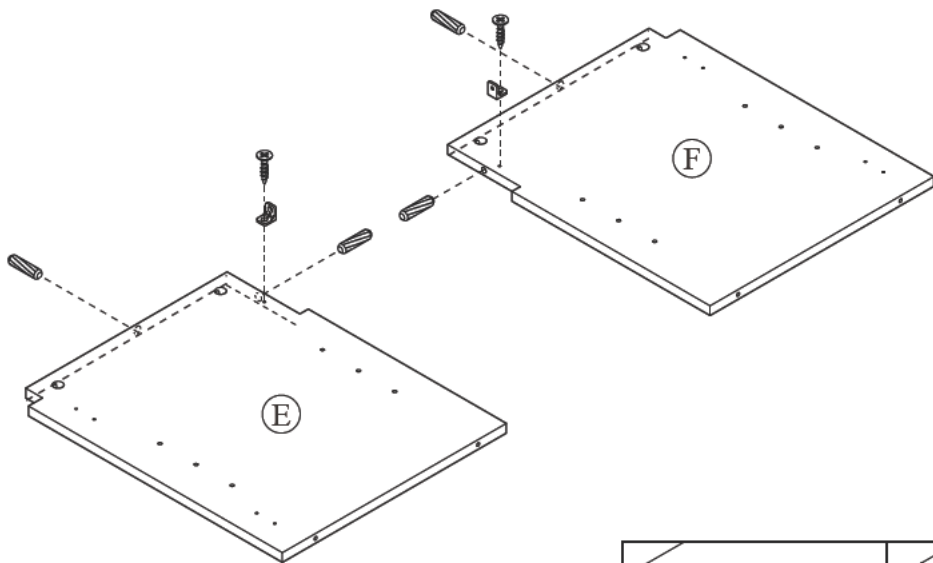

STEP 17

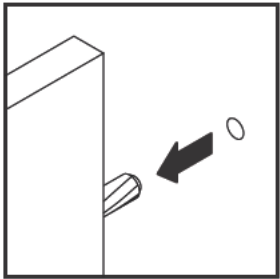
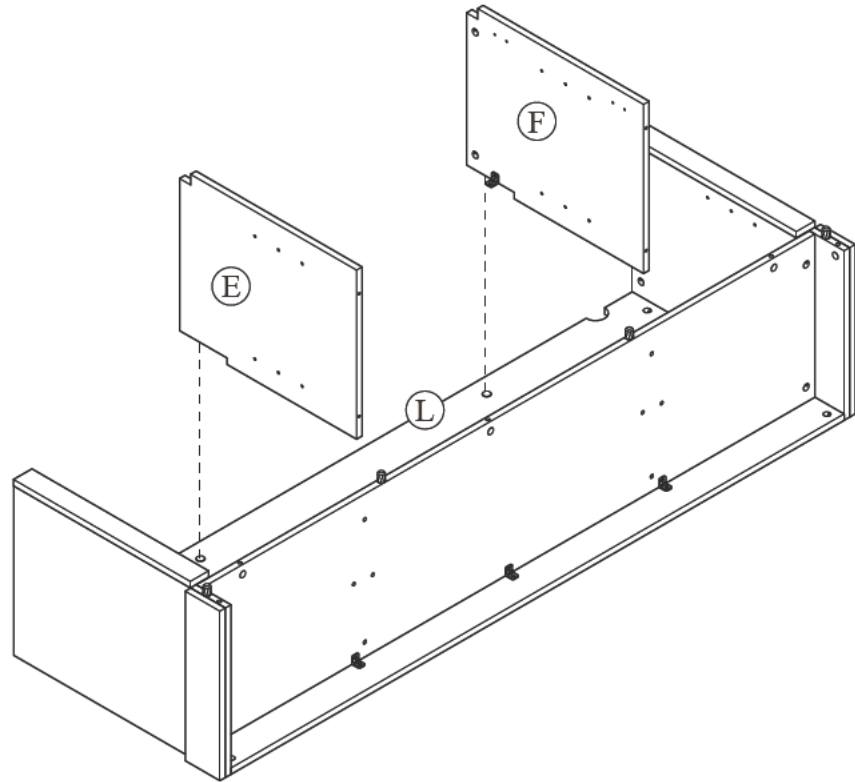

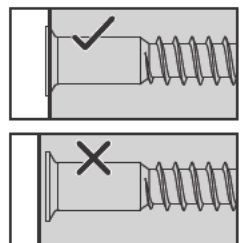
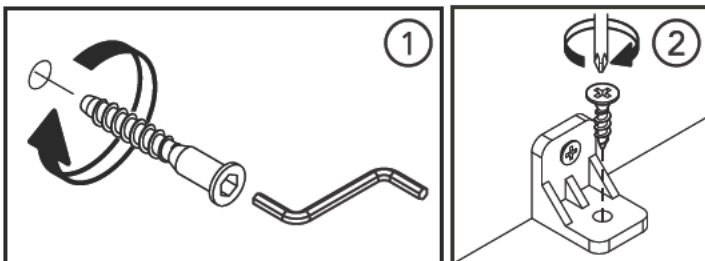
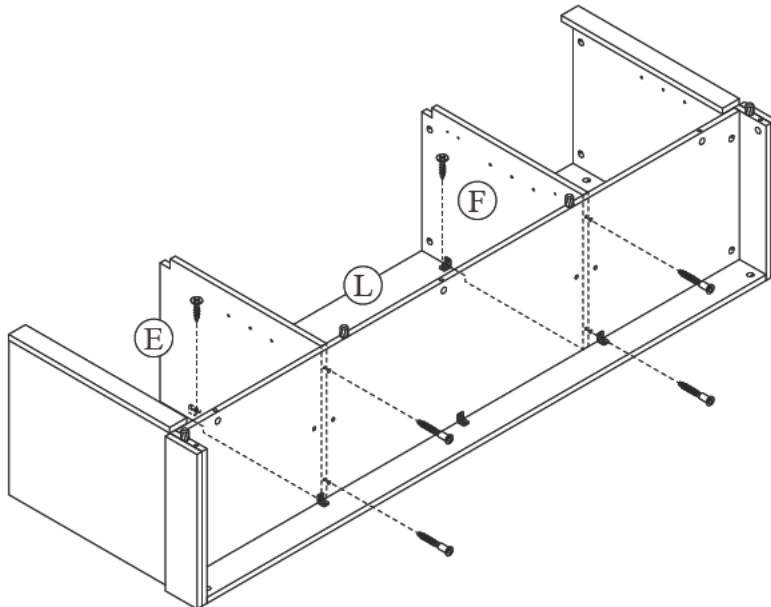

STEP 18

| | |
|---|---|
|  |  |
| E x 4 | F x 2 |



STEP 19

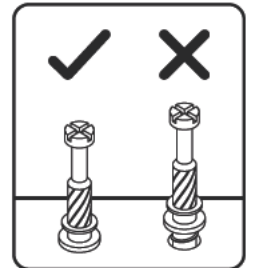
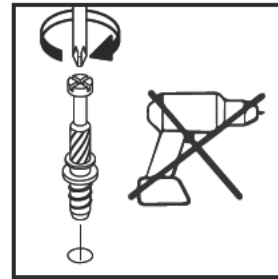
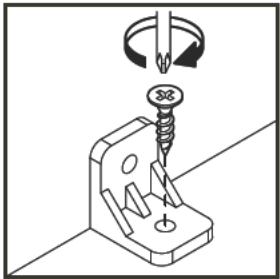
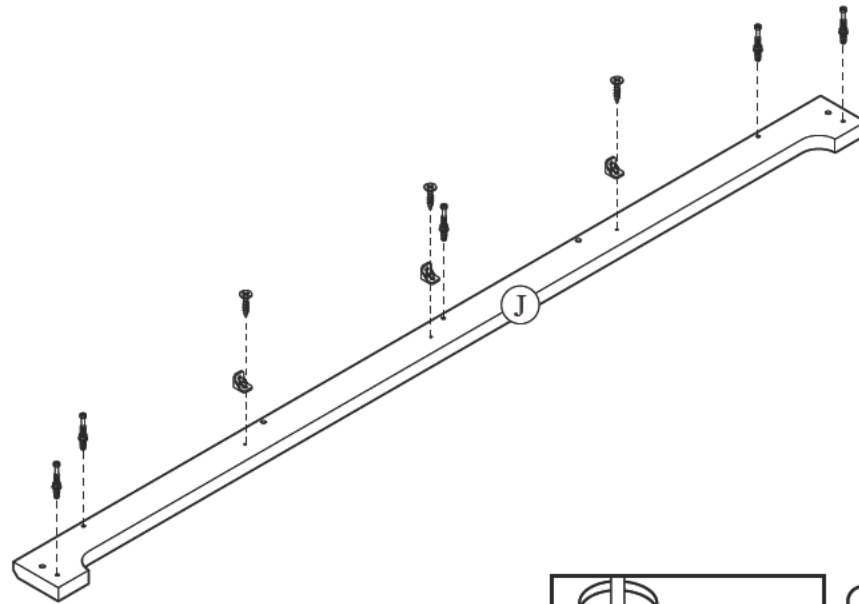

| | | |
|--|---|---|
|  |  |  |
| A x 5 | F x 3 | J x 3 |

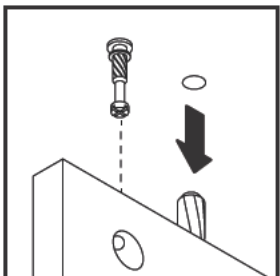
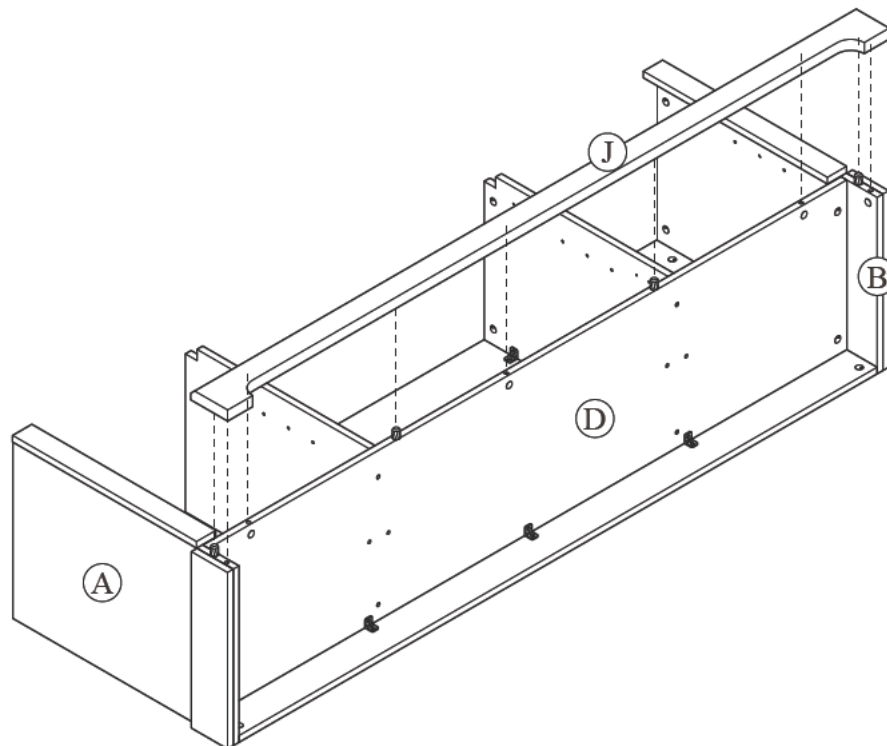

STEP 20



STEP 21

| | |
|--|---|
|  |  |
| B x 5 | F x 3 |

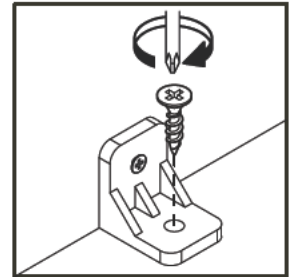
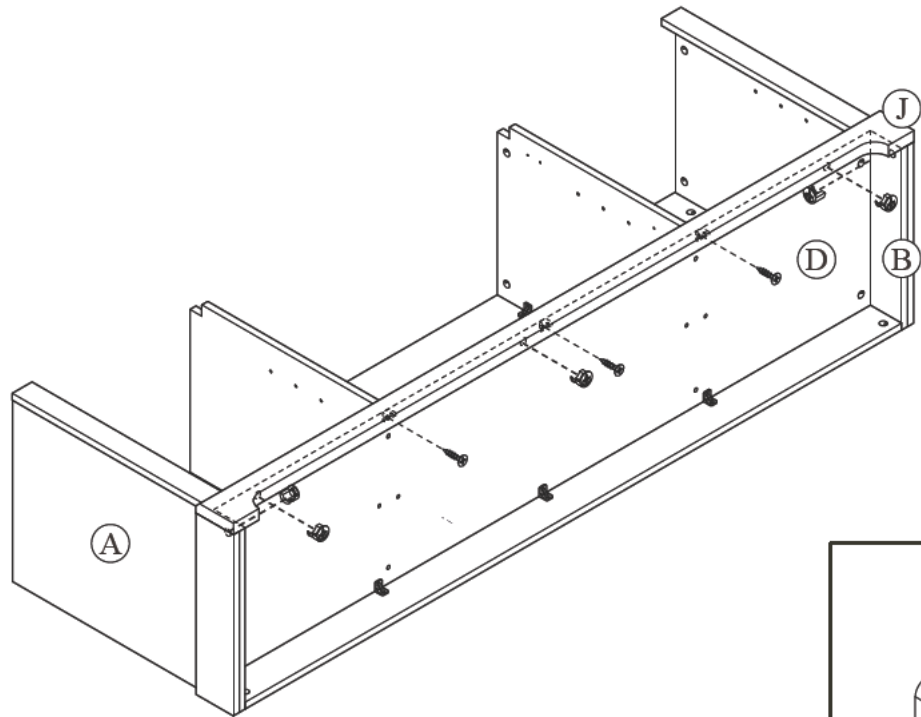
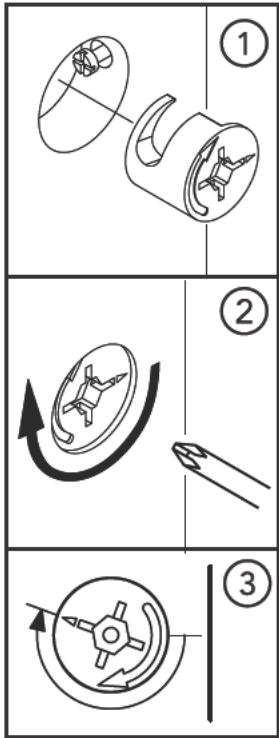

STEP 22

| |
|---|
|  |
| Q x 4 |

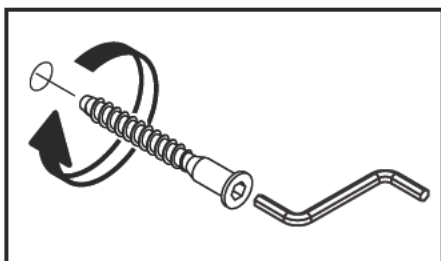
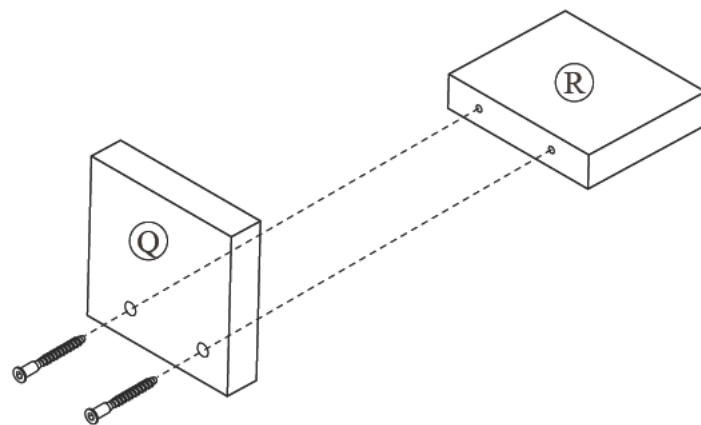
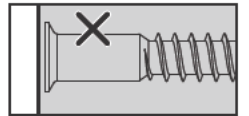
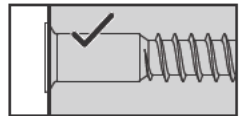

STEP 23

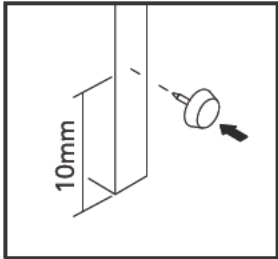
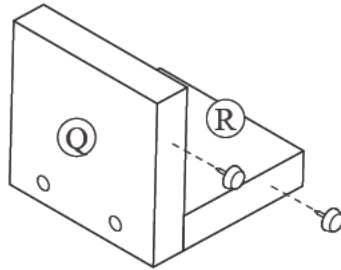
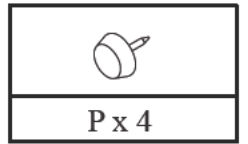

(2x)

STEP 24

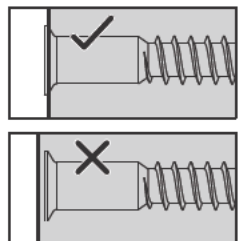
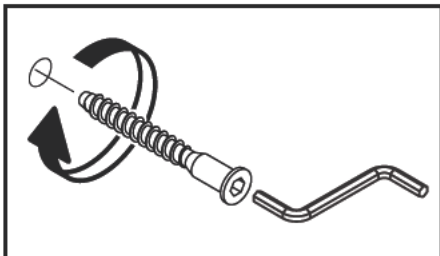
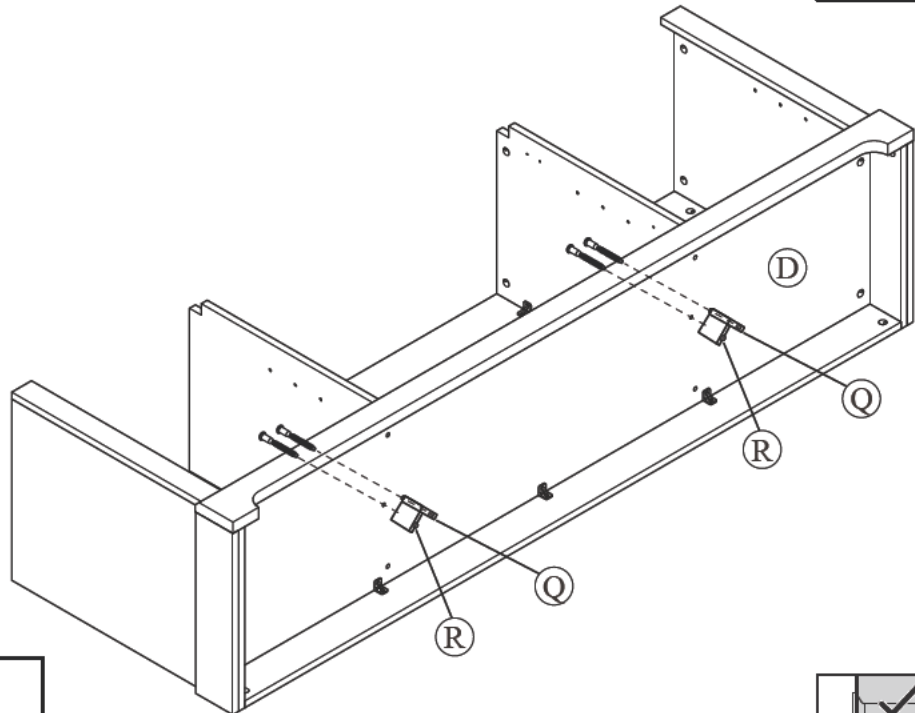
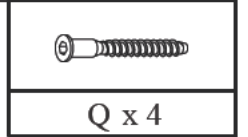

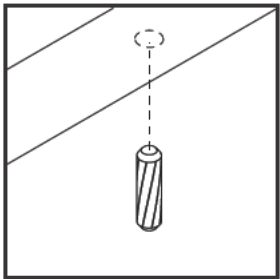
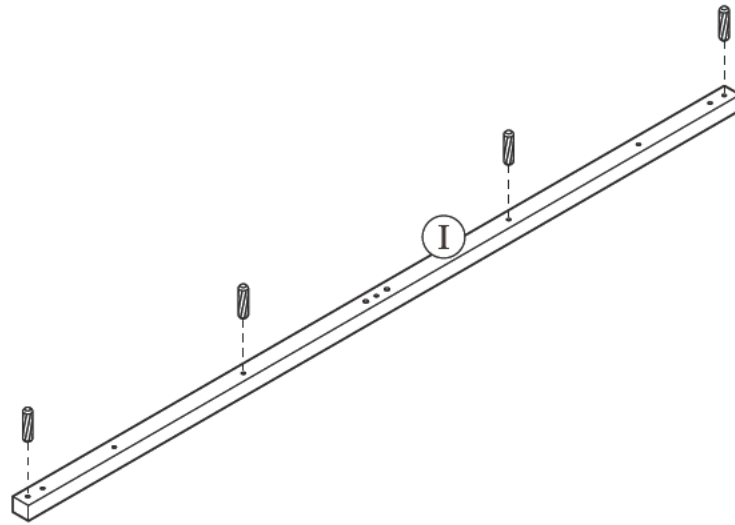
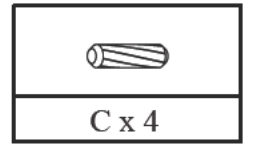

STEP 25

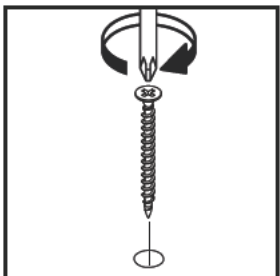
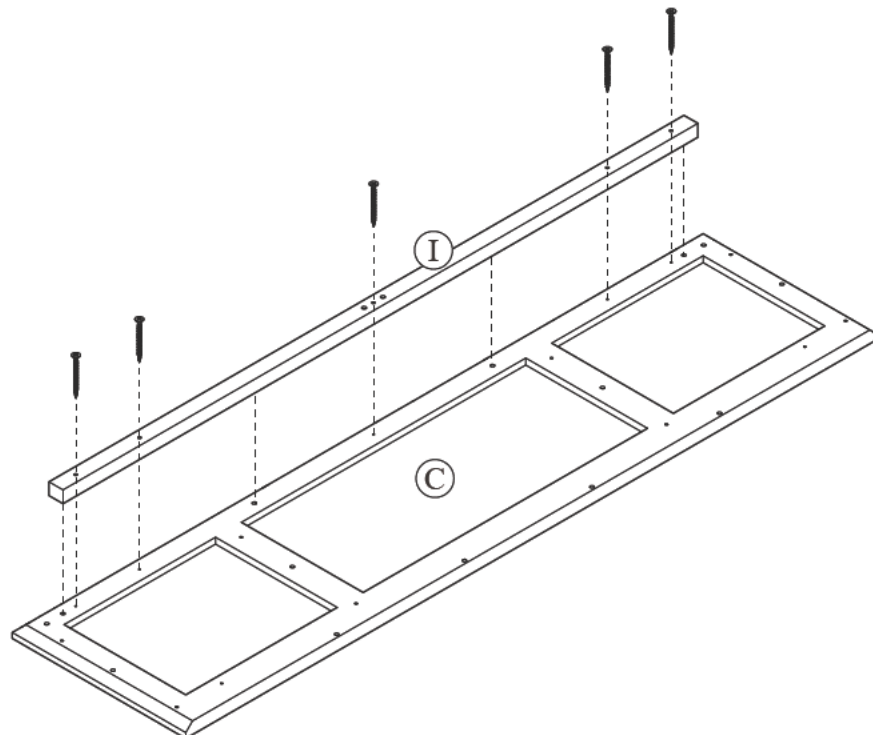
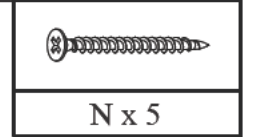

STEP 26



STEP 27

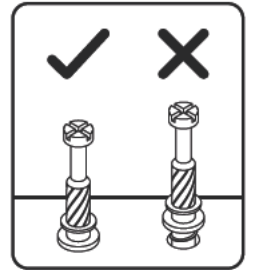
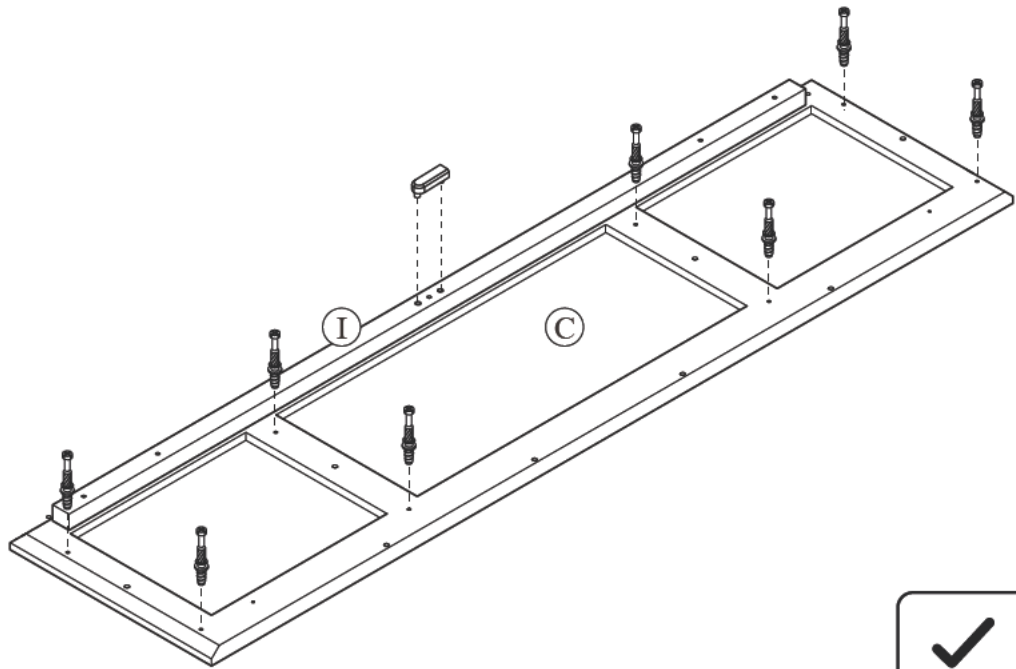
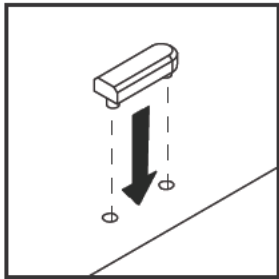
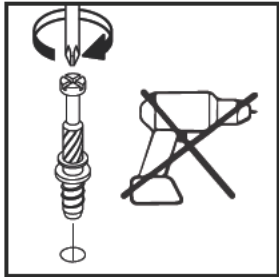

| | |
|---|---|
|  |  |
| A x 8 | K x 1 |

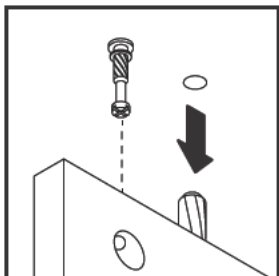
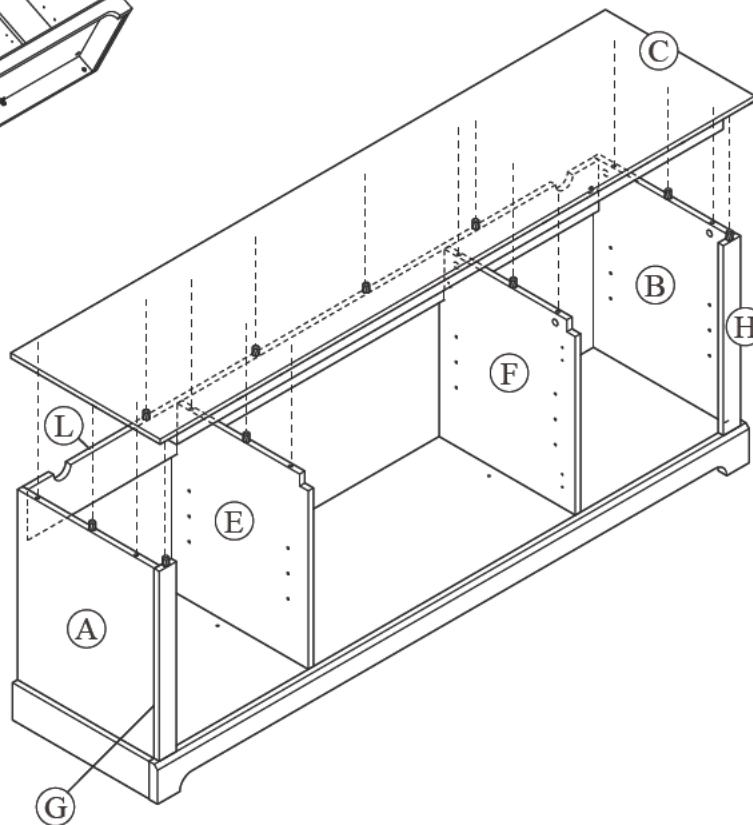
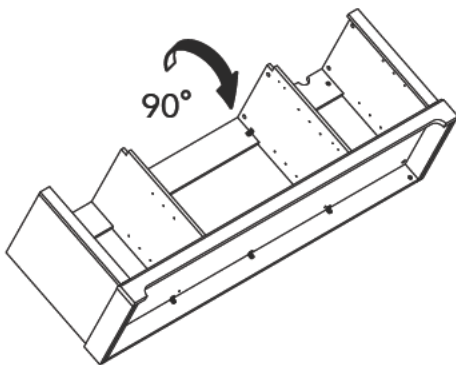

STEP 28



STEP 29

| | |
|--|--|
|  |  |
| B x 8 | K x 1 |

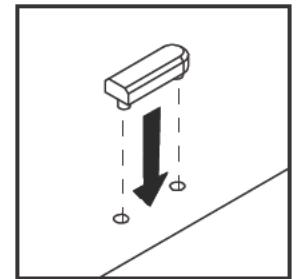
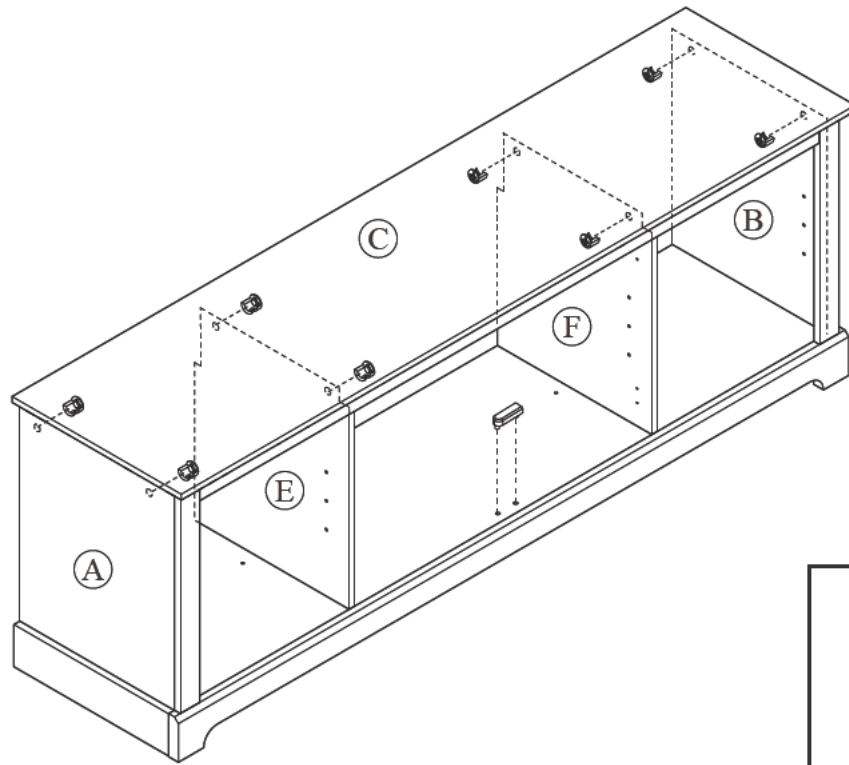
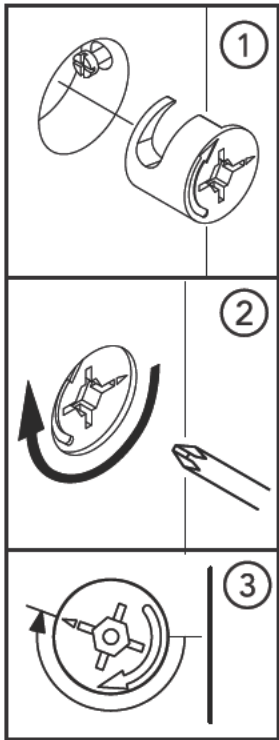

STEP 30

| | |
|---|---|
|  |  |
| F x 6 | G x 16 |

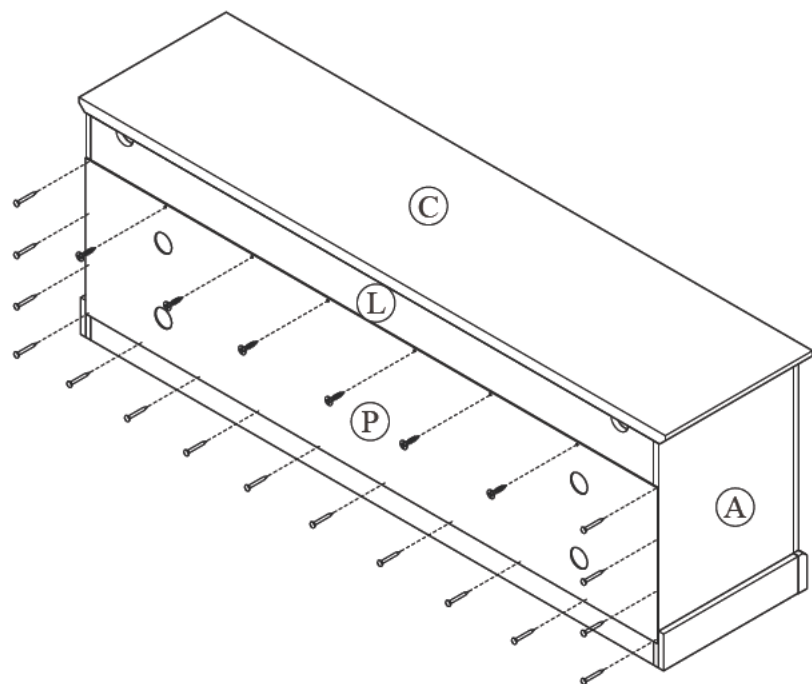
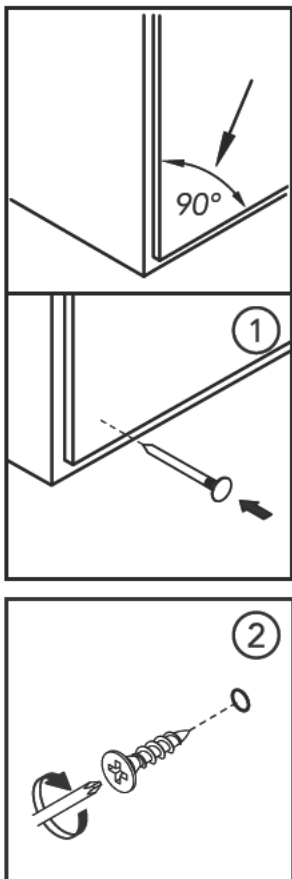

FURNITURE TIPPING RESTRAINT

SEGURO CONTRA VOLCADO DE MUEBLES

DISPOSITIF DÉ SÉCURITÉ POUR MEUBLES

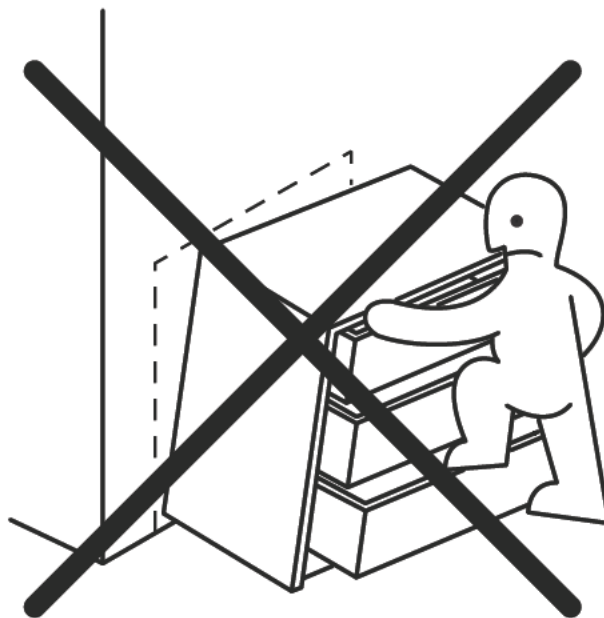
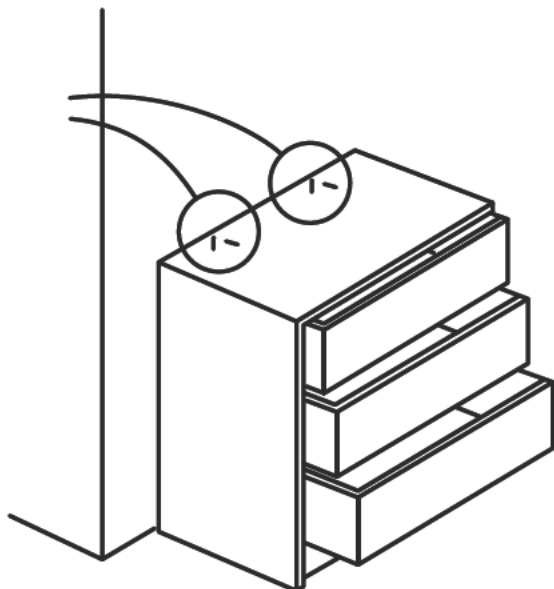

STEP 31

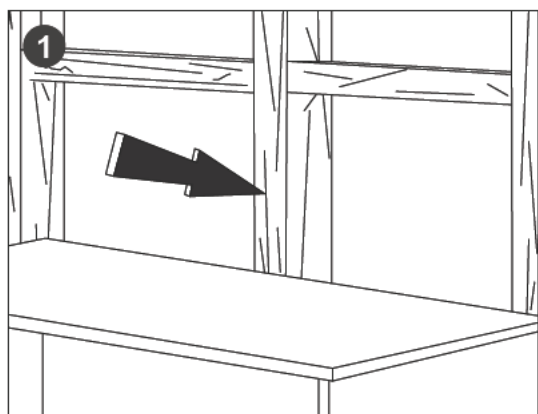

Locate a wall stud:

- Move the furniture unit to its final position to the wall
- Locate a wall stud behind the furniture unit

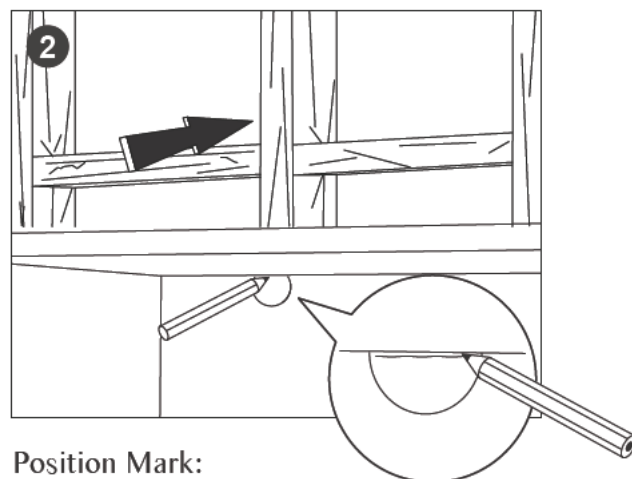

Position Mark:

- Use the Pencil to mark the positioning hole on a wall stud

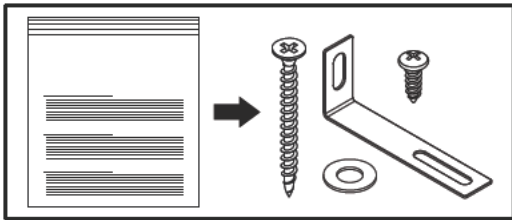

| | | | |
|--------|--------|--------|--------|
| | | | |
| AA x 2 | BB x 2 | CC x 2 | DD x 2 |

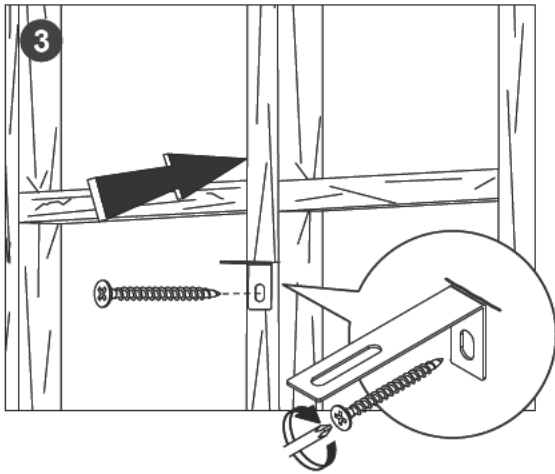

Screw the safety bracket to the wall stud:
 - Screw the safety bracket (AA) to the wall stud with Screw (DD)

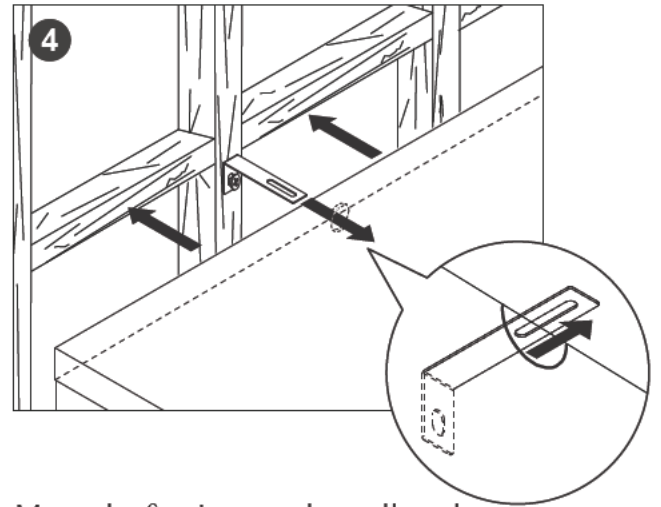

Move the furniture to the wall stud
 - Move the furniture to the wall stud and make sure the safety bracket in the hole

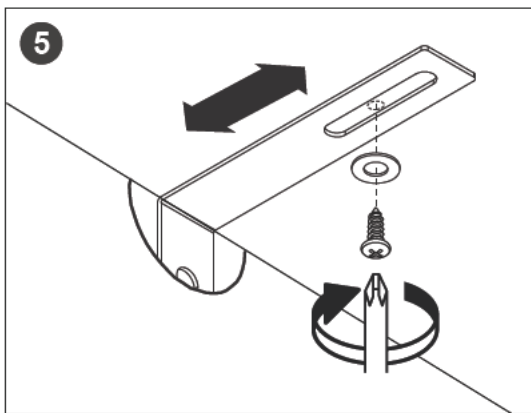

Screw the safety bracket to the furniture
 - Screw the safety bracket to the bottom Top Furniture with Flat Washer (BB) and Screw (CC)

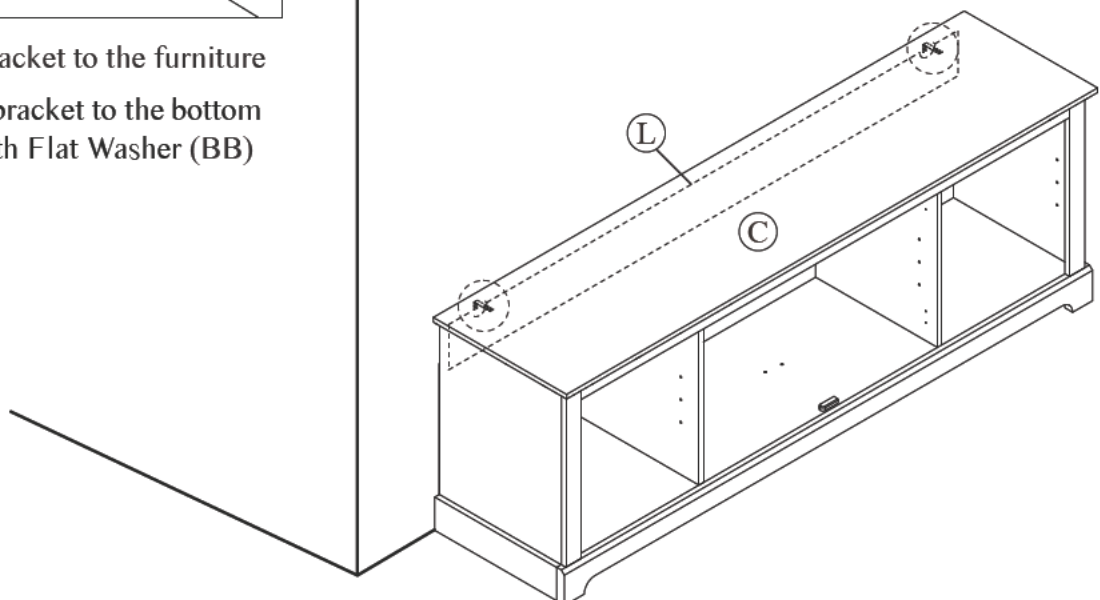

STEP 32

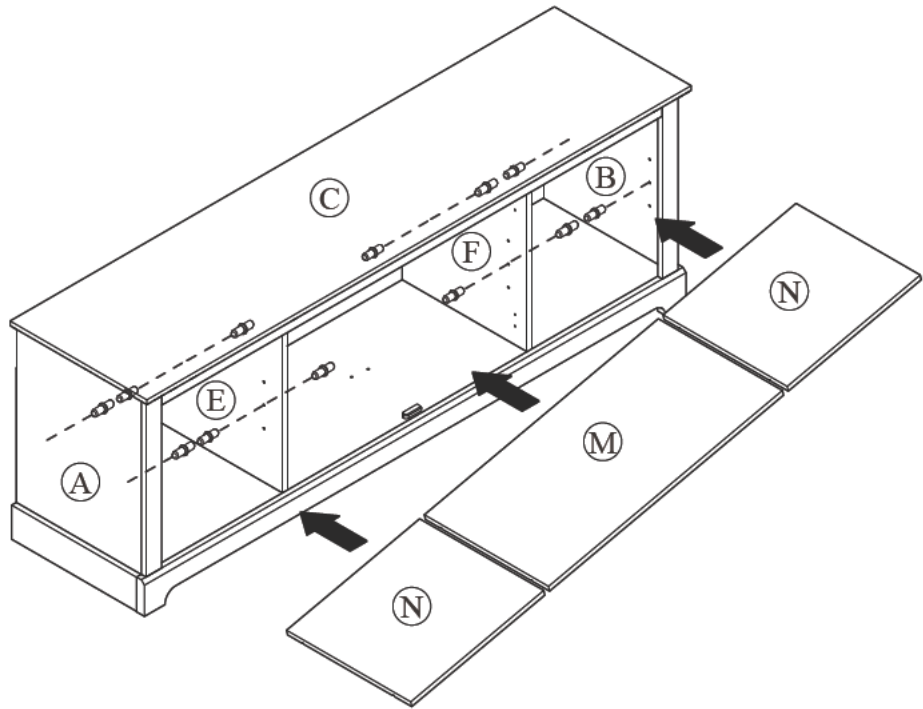
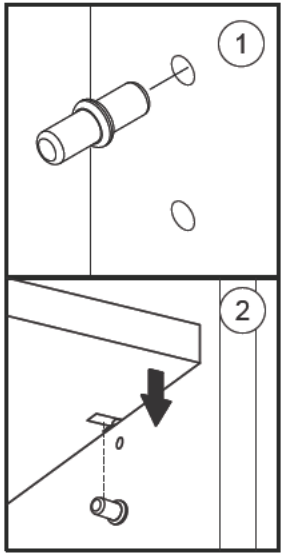

STEP 33

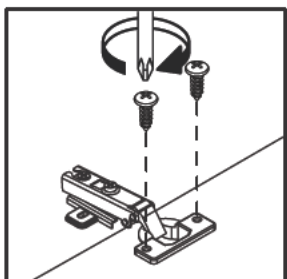
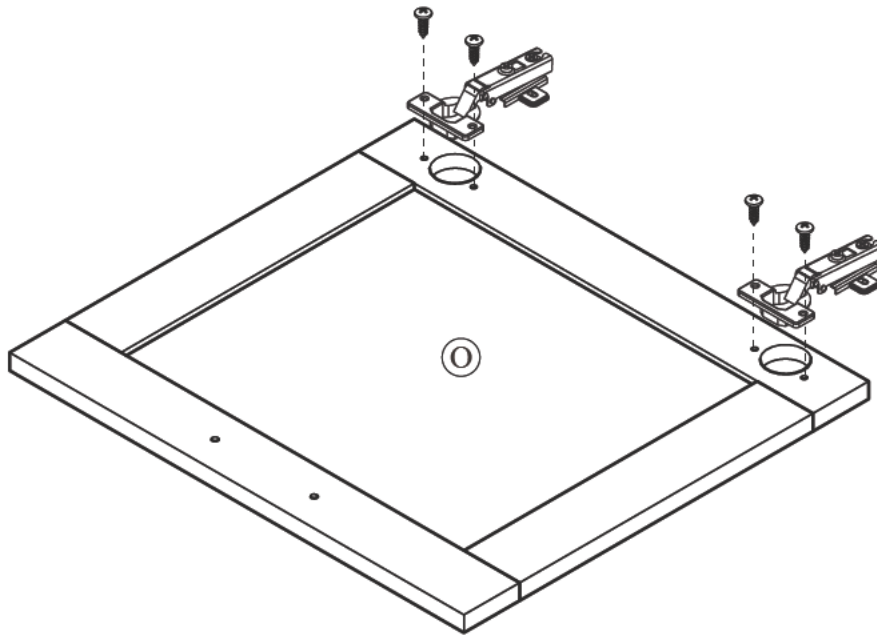
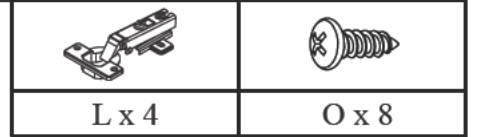

(2x)

STEP 34

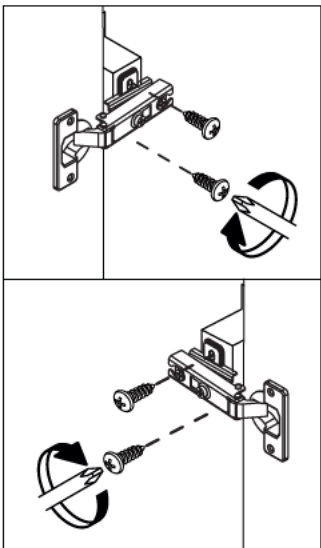
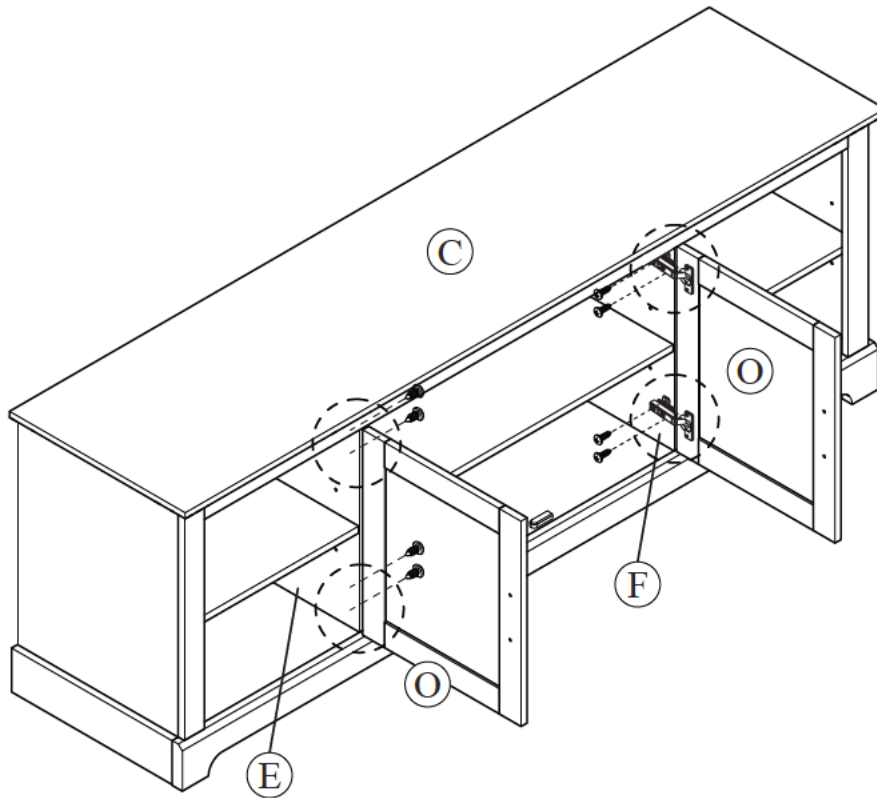
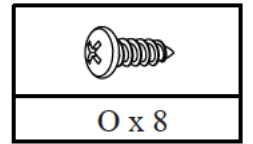

SPECIAL TIPS FOR DOOR ALIGNMENT

CONSEJOS ESPECIALES PARA LA ALINEACIÓN DE PUERTAS

CONSEILS SPÉCIAUX POUR L'ALIGNEMENT DES PORTES

- A. Lateral adjustment (Moving door left-right) by screw adjusting
Ajuste lateral (Puerta móvil de izquierda a derecha) mediante tornillo de ajuste
Réglage latéral (porte mobile gauche-droite) par réglage à vis

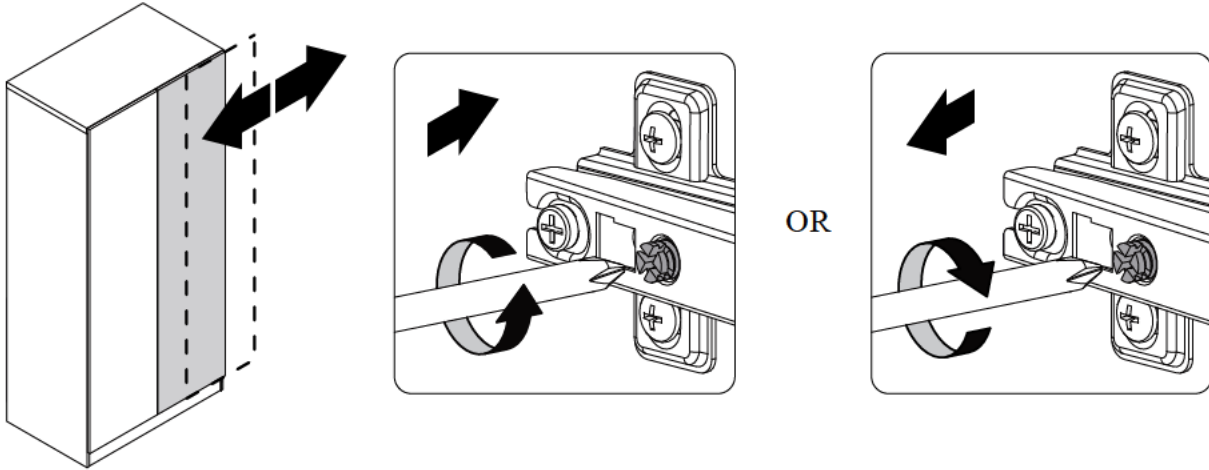

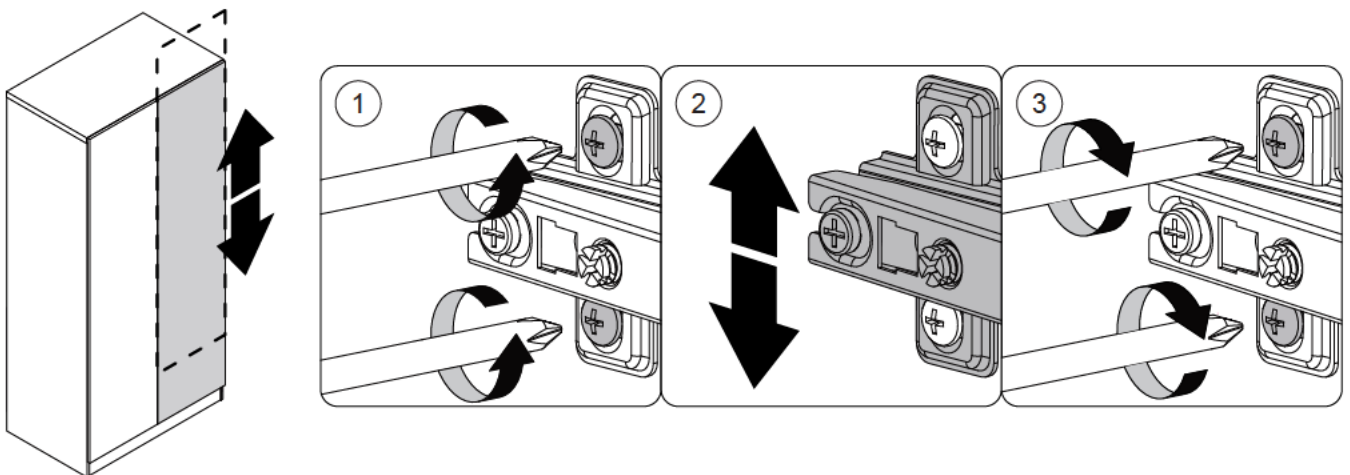

- B. Vertical adjustment (Moving door up-down) via the slot on the mounting plate
Ajuste vertical (Puerta móvil arriba-abajo) a través de la ranura en la placa de montaje
Réglage vertical (porte mobile de haut en bas) via la fente sur la plaque de montage

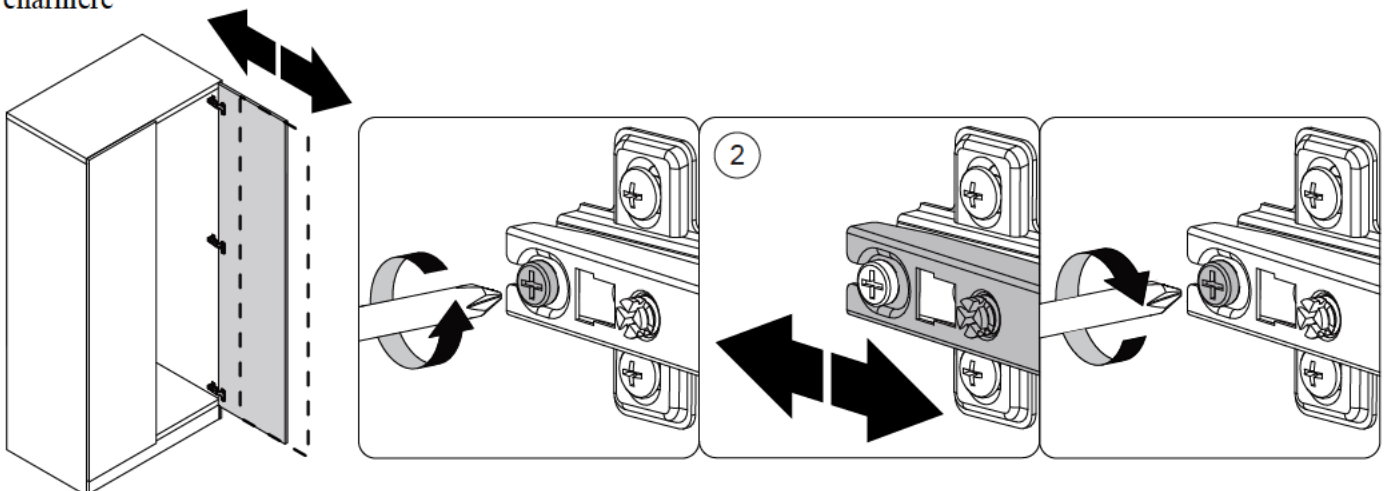

- C. Front-to-back adjustment (Spacing Door Off Cabinet) by slacking the hinge arm mounting screw
Ajuste de adelante hacia atrás (espaciado entre la puerta y el gabinete) aflojando el tornillo de montaje del brazo de la bisagra
Ajustement d'avant en arrière (espacement de la porte hors de l'armoire) en desserrant la vis de montage du bras de charnière



STEP 35

| | |
|---|--|
|  |  |
| D x 4 | H x 2 |

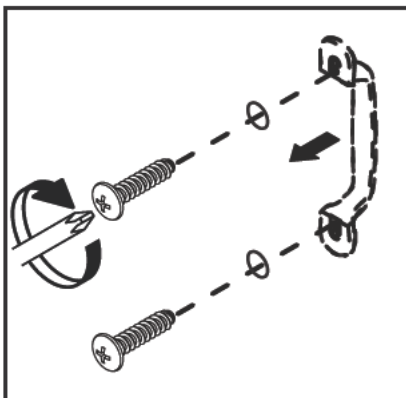
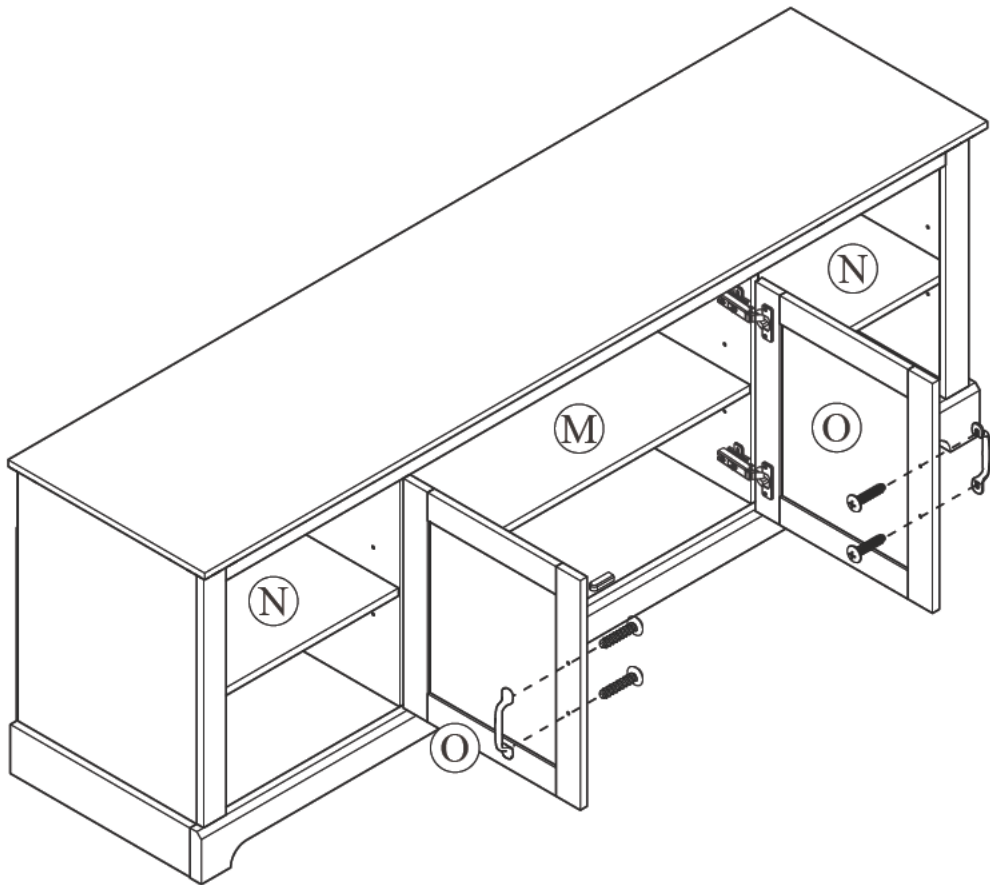

MAXIMUM LOADS CHARGES MAXIMALES / CARGA MAXIMA

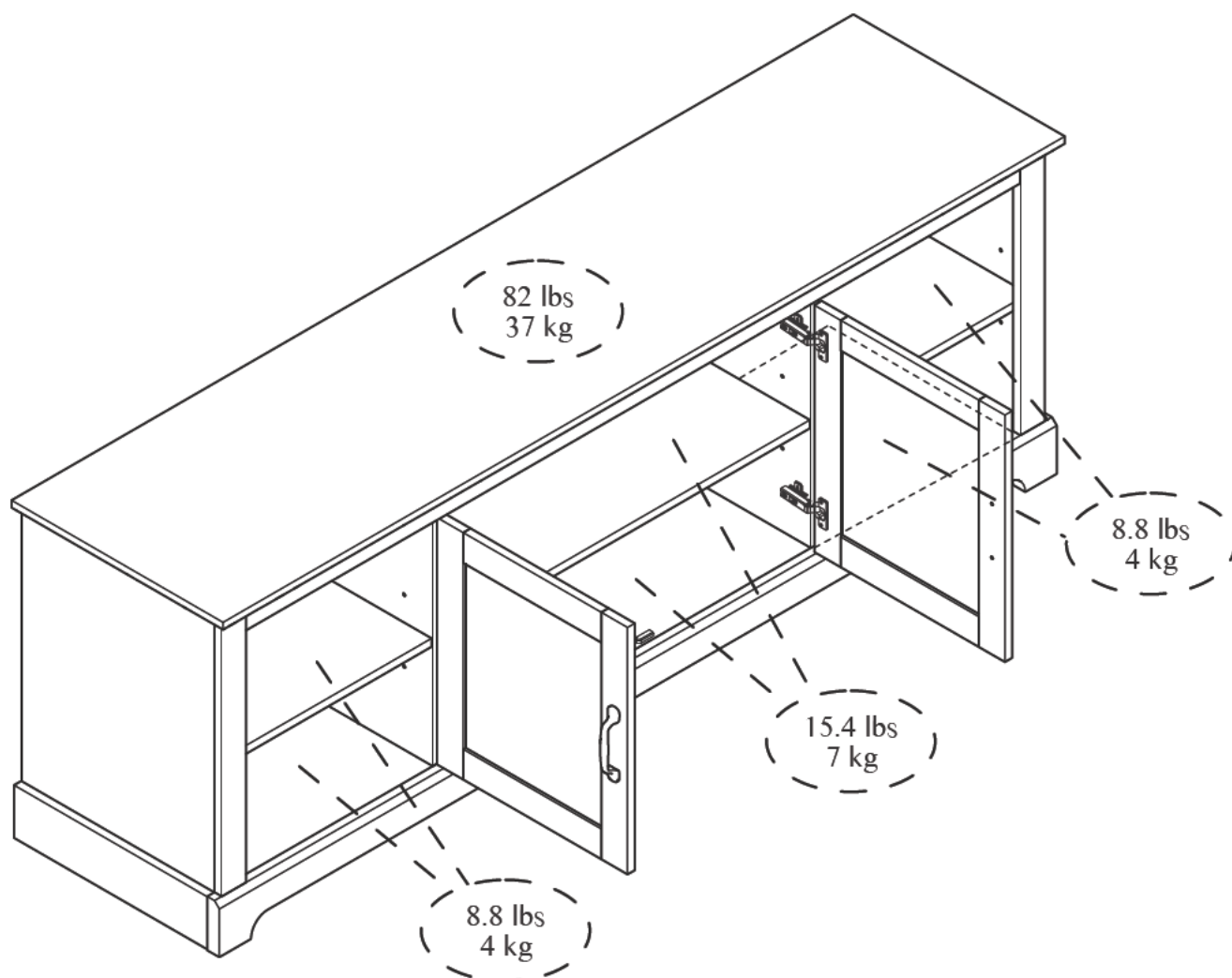

This product is designed to withstand the weight noted on the plan. We are not responsible for the breakage of parts or any injury caused by failure to comply with this recommendation.

Ce produit est conçu pour supporter le poids indiqué sur le plan. Nous ne sommes pas responsables de la casse de pièces ou toute blessure causée par le non-respect de cette recommandation.

Este producto está diseñado para soportar el peso indicado en el plano. No somos responsables de la rotura de piezas o cualquier lesión causada por el incumplimiento de esta recomendación.
