

# ASSEMBLY INSTRUCTION

## JULIUS COLLECTION











MODEL : D1802-10 JULIUS 66" RECTANGLE DINING TABLE

Thank you for purchasing this quality product. Be sure to check all packing materials carefully for small parts, which may have come loose inside the carton during shipment. Identify and count all items and compare with the parts list and/or hardware list shown below.

Please read all instructions carefully. See the hardware and furniture part listing for guidance. Be sure you have all parts listed before beginning assembly. Place all wooden parts on a clean, flat surface to protect the finish from scratches. Follow the diagram to assemble.

### CAUTION

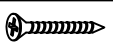
1. Do not fully tighten the nuts or bolts until the table is fully assembled.
2. Please tighten by hand, not by a drill. Overtightening will damage threads. Do not overtighten.
3. Keep all hardware out of the reach of children.

PARTS LIST				HARDWARE LIST			
ITEM	DESCRIPTION	SKETCH	QTY	ITEM	DESCRIPTION	SKETCH	QTY
A	TABLE TOP		1 PC	1	SHORT BOLT M8 x 2"		2 PCS
B	RIGHT SIDE FACING LEG WITH LABEL "R"		2 PCS	2	LONG BOLT M8 x 2-6/8"		8 PCS
C	LEFT SIDE FACING LEG WITH LABEL "L"		2 PCS	3	SPRING WASHER M8 x 1/2"		10 PCS
D	X LEG SUPPORT		2 PCS	4	FLAT WASHER M8 x 7/8"		8 PCS
E	TABLE STRETCHER		1 PC	5	SCREW M4 x 2"		4 PCS
				6	ALLEN KEY M5 2-9/16"		1 PC

HARDWARE DIMENSIONS  
VERIFICATION TOOL

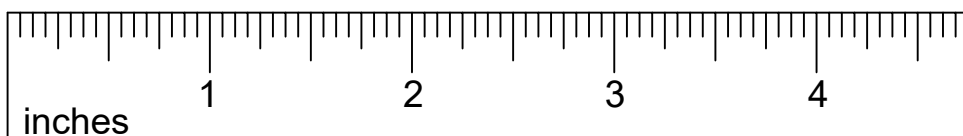

- STEP 1** Attached the RIGHT SIDE FACING LEG (B) and the LEFT SIDE FACING LEG (C) to the X leg support (D).
- \* Please make sure the hole on the X leg support is facing the front and to the bottom when attaching the legs.
  - \* DO NOT ASSMEBLE THE PIECES TOGETHER WITH SCREWS
- Repeat the step to create the other leg base.

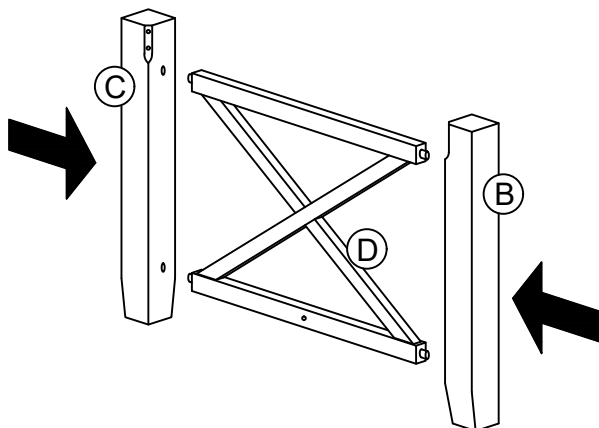

**STEP 2** Place the table top (A) upside down on a soft and flat surface. Assemble the leg bases to the table top (A) by using the Allen Key (6) with hardware 2, 3, and 4.  
**\*DO NOT TIGHTEN THE BOLTS.**

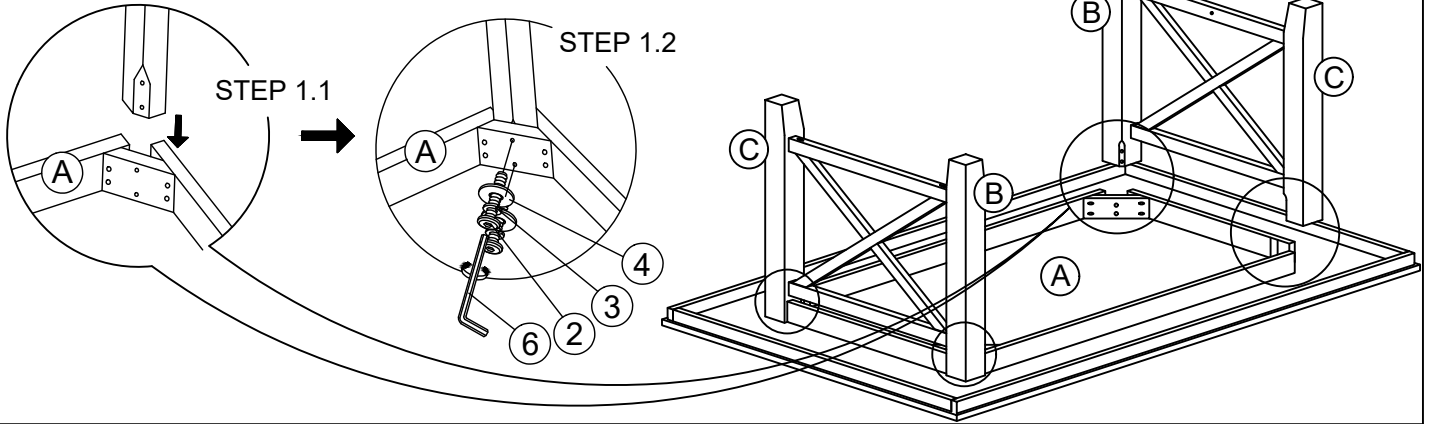

**STEP 3** Assemble the Table stretcher (E) to the leg bases by using Allen Key (6) with hardware 1 and 3.

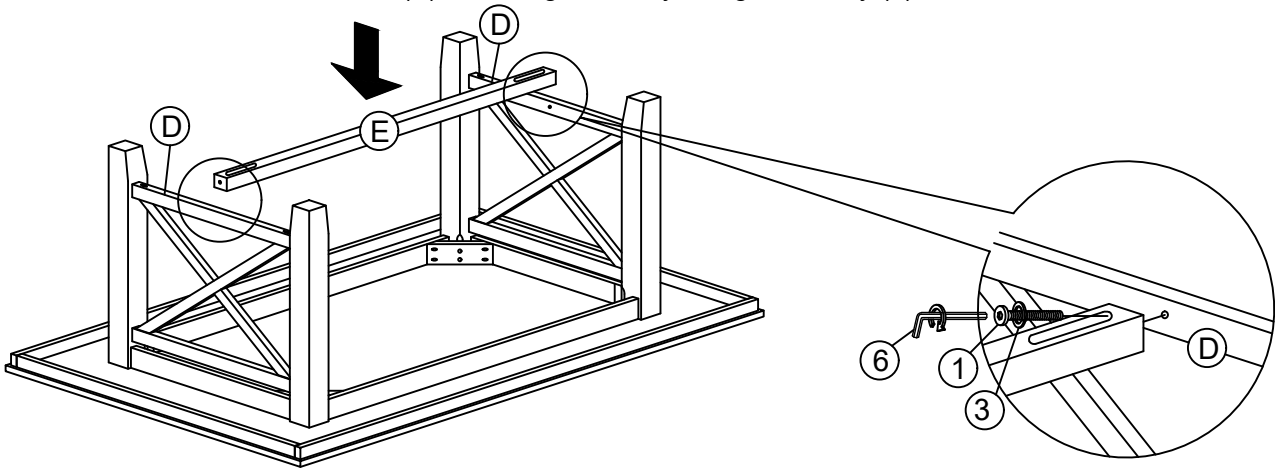

**STEP 4** Assemble the leg bases by using a screwdriver with hardware 5.

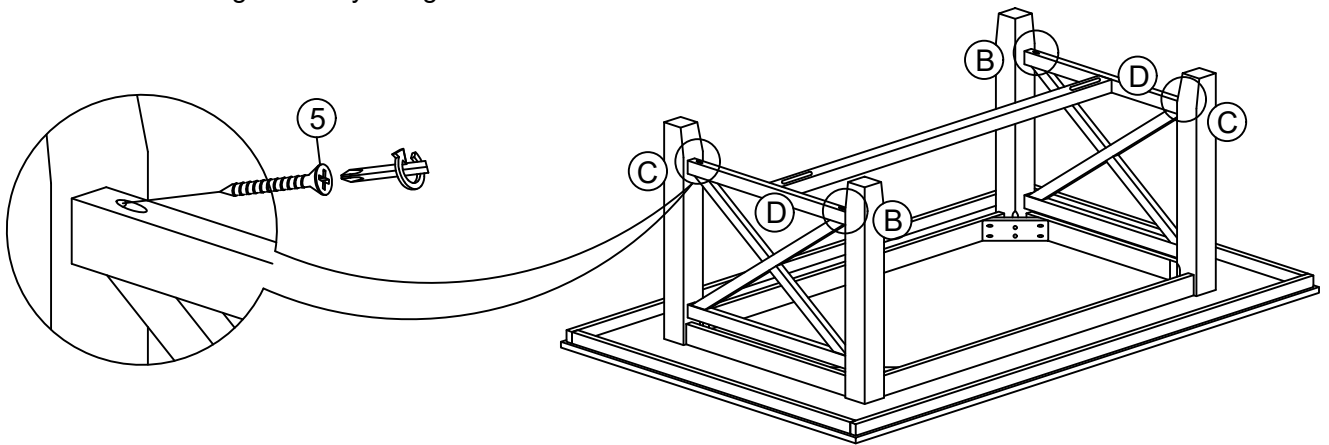

**STEP 5** To level the table, turn the table right side up and tighten the bolts with Allen key (6).

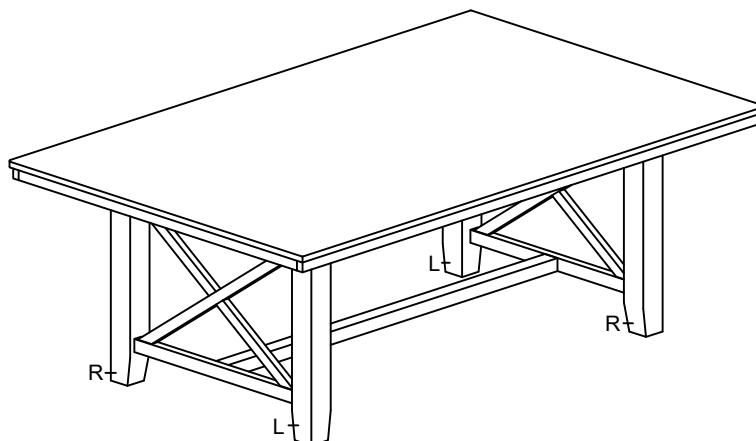

FULLY SET-UP

# ASSEMBLY INSTRUCTION

## JULIUS COLLECTION











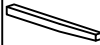

MODEL : D1802-20 JULIUS DINING CHAIR  
(2 Per Carton)

Thank you for purchasing this quality product. Be sure to check all packing materials carefully for small parts, which may have come loose inside the carton during shipment. Identify and count all items and compare with the parts list and/or hardware list shown below.

Please read all instructions carefully. See the hardware and furniture part listing for guidance. Be sure you have all parts listed before beginning assembly. Place all wooden parts on a clean, flat surface to protect the finish from scratches. Follow the diagram to assemble.

### CAUTION

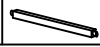
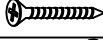
1. Do not fully tighten the nuts or bolts until the table is fully assembled.
2. Please tighten by hand, not by a drill. Overtightening will damage threads. Do not overtighten.
3. Keep all hardware out of the reach of children.

PARTS LIST				HARDWARE LIST			
ITEM	DESCRIPTION	SKETCH	QTY	ITEM	DESCRIPTION	SKETCH	QTY
A	BACKREST		2 PCS	1	SHORT BOLT M6 x 1-5/8"		4 PCS
B	SEAT		2 PCS	2	MEDIUM BOLT M6 x 2-3/8"		8 PCS
C	RIGHT SIDE FACING LEG w/ LABEL "R"		2 PCS	3	LONG BOLT M6 x 3-3/16"		8 PCS
D	LEFT SIDE FACING LEG w/ LABEL "L"		2 PCS	4	SPRING WASHER M6 x 7/16"		20 PCS
E	RIGHT SIDE FACING STRETCHER w/ LABEL "R"		2 PCS	5	FLAT WASHER M6 x 6/8"		20 PCS
F	LEFT SIDE FACING STRETCHER w/ LABEL "L"		2 PCS	6	SCREW M4 x 1-1/2"		8 PCS
				7	ALLEN KEY M4 3-15/16"		1 PC

### HARDWARE DIMENSIONS VERIFICATION TOOL

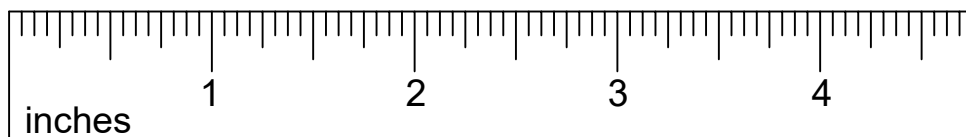

**STEP 1:** Place the Backrest (A) on a soft and clean surface.

Assemble the Seat (B) with the Backrest (A) by using Allen key (7) with hardware 1, 4, and 5.

**\*\* Attention: DO NOT TIGHTEN THE BOLTS.**

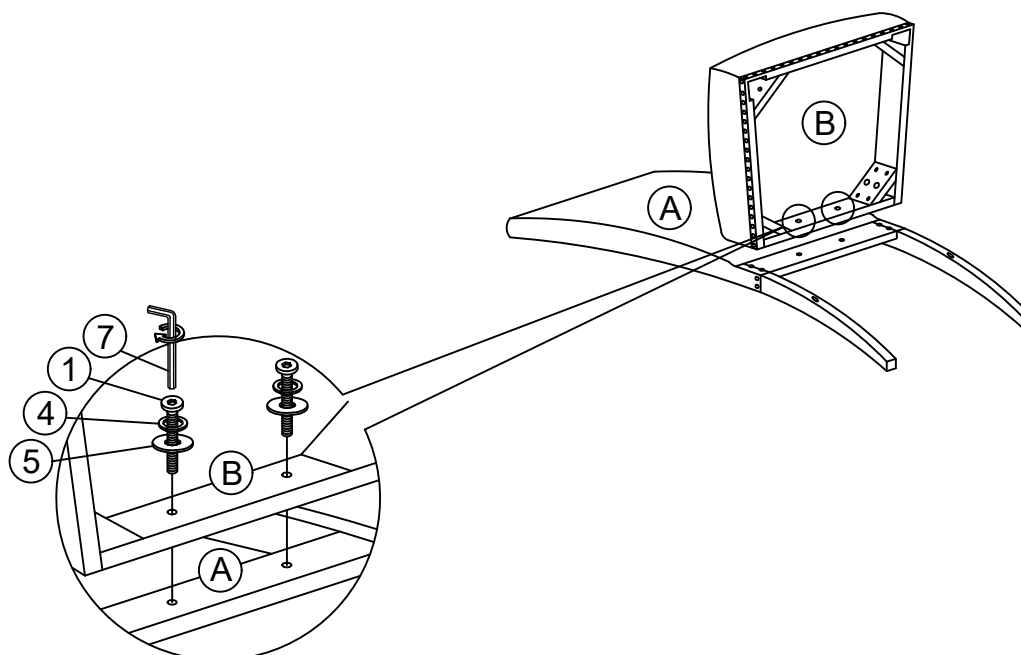

**STEP 2:** Assemble the Seat Frame (B) with the back legs of Backrest (A) by using Allen key (7) with hardware 3, 4, and 5.  
\*\* Attention: DO NOT TIGHTEN THE BOLTS.

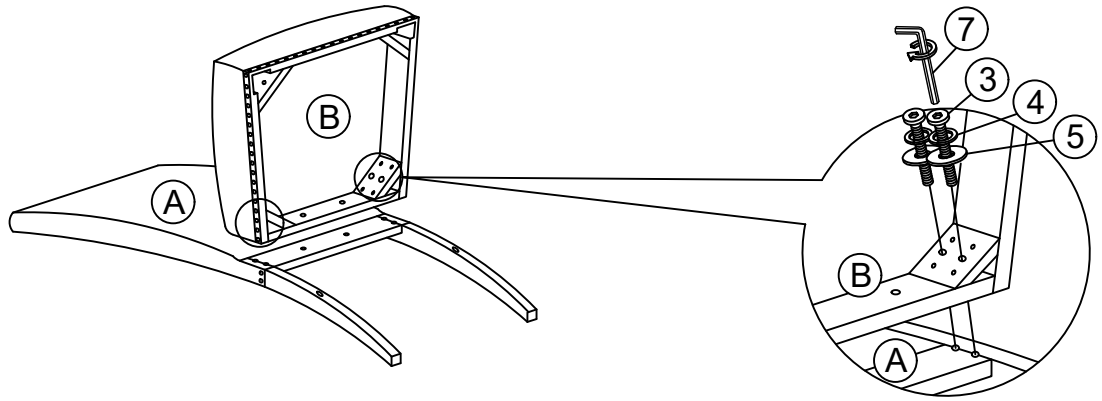

**STEP 3:** Place RIGHT SIDE FACING STRETCHER (E) and between backrest (A) and RIGHT SIDE FACING LEG (C), then LEFT SIDE FACING STRETCHER (F) between backrest (A) and LEFT SIDE FACING LEG (D). Assemble the legs (C & D) with the seat (B) by using Allen key (7) with hardware 2, 4, and 5.  
\*\* Attention: DO NOT TIGHTEN THE BOLTS.

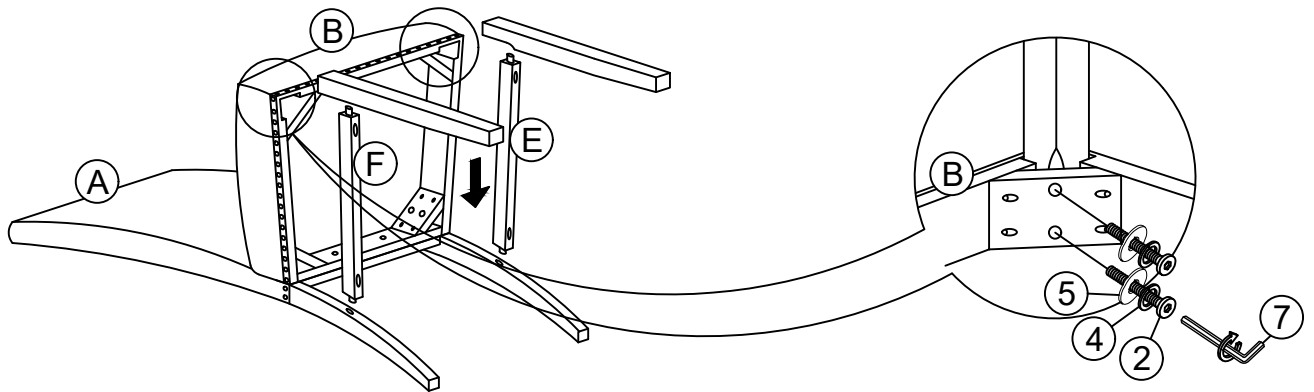

**STEP 4:** Assemble the stretcher (E & F) by using screwdriver with screw (6).

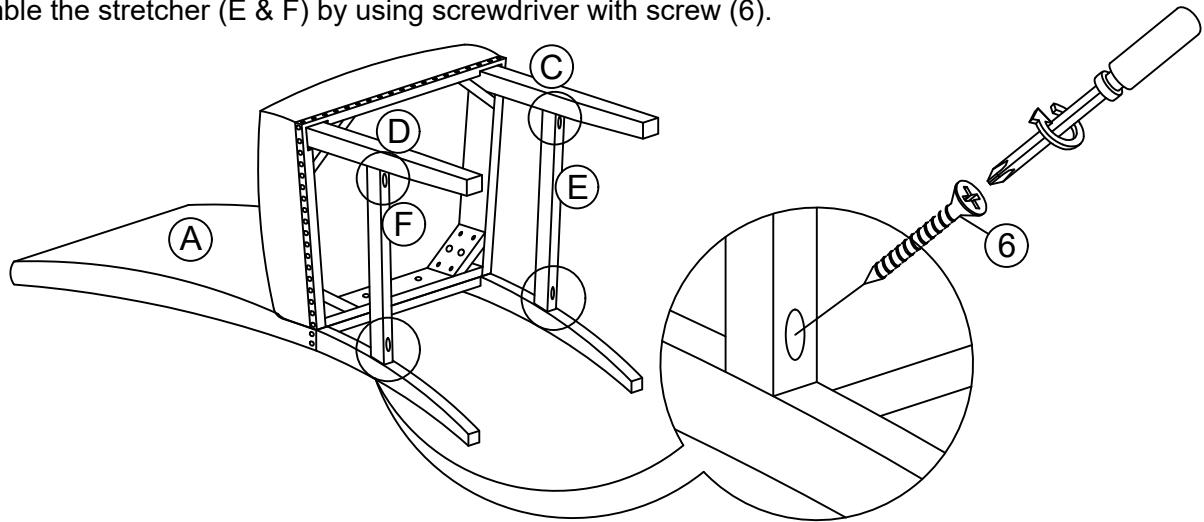

**STEP 5:** To level the chair, stand the chair up on a flat surface and tighten all the bolts by using Allen Key (7) and all the screws with a screwdriver.

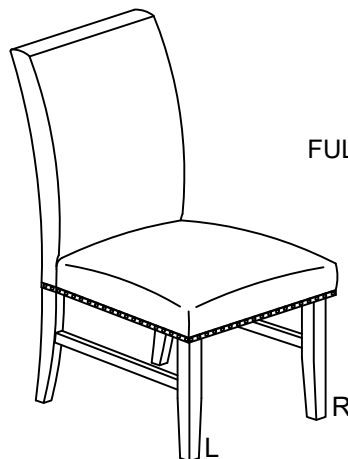

FULLY SET-UP

# ASSEMBLY INSTRUCTION

## JULIUS COLLECTION



MODEL : D1802-25 JULIUS BENCH

Thank you for purchasing this quality product. Be sure to check all packing materials carefully for small parts, which may have come loose inside the carton during shipment. Identify and count all items and compare with the parts list and/or hardware list shown below.

Please read all instructions carefully. See the hardware and furniture part listing for guidance. Be sure you have all parts listed before beginning assembly. Place all wooden parts on a clean, flat surface to protect the finish from scratches. Follow the diagram to assemble.

### CAUTION

1. Do not fully tighten the nuts or bolts until the table is fully assembled.
2. Please tighten by hand, not by a drill. Overtightening will damage threads. Do not overtighten.
3. Keep all hardware out of the reach of children.

PARTS LIST			
ITEM	DESCRIPTION	SKETCH	QTY
A	CUSHION SEAT		1 PC
B	LEG		4 PCS

HARDWARE LIST			
ITEM	DESCRIPTION	SKETCH	QTY
1	BOLT M6 x 2-3/8"		8 PCS
2	SPRING WASHER M6 x 7/16"		8 PCS
3	FLAT WASHER M6 x 6/8"		8 PCS
4	ALLEN KEY M4 3-15/16"		1 PC

### HARDWARE DIMENSIONS VERIFICATION TOOL

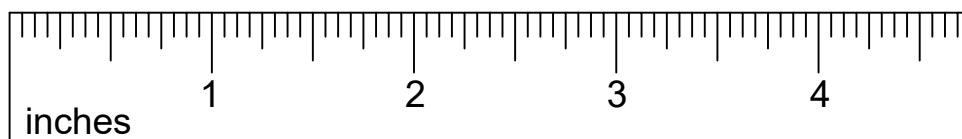

**STEP 1:** Assemble each leg (B) to cushion saet (A) with Flat Washer(3), Spring Washer(2) and BOLT(A) as shown and tighten with Allen Key (4).

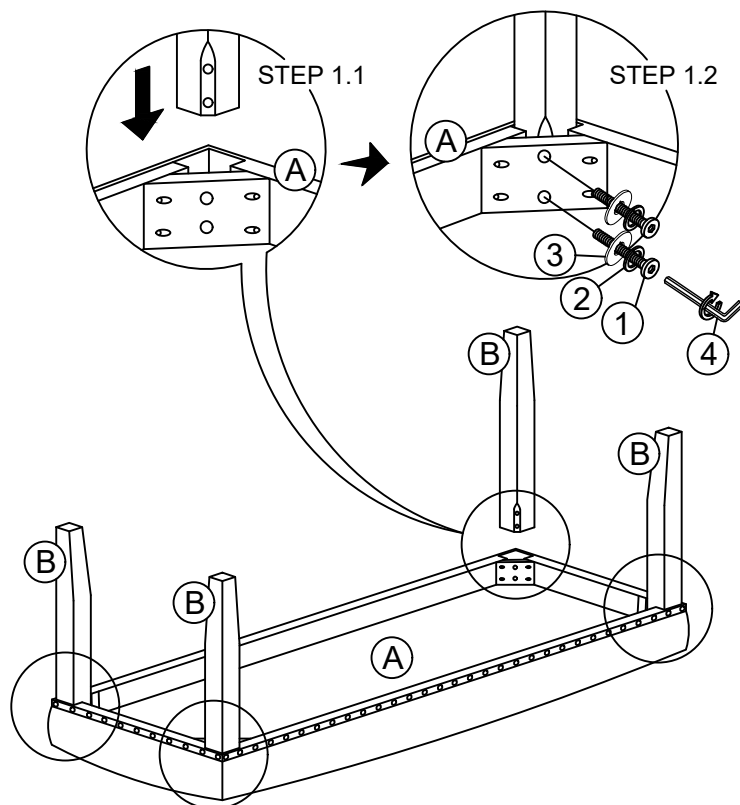

FULLY SET-UP

