







ASSEMBLY INSTRUCTION

Thank you for purchasing this quality product. Be sure to check all packing material carefully for small parts which may have come loose inside the carton during shipment. Separate, identify and count all parts and hardware. Compare with the parts list to be sure all parts are present.
"DO NOT TIGHTEN SCREWS UNTIL COMPLETELY ASSEMBLED"

IMPORTANT:
 PLEASE READ INSTRUCTION BEFORE STARTING ASSEMBLY

Hardware List:

NO.	Description	Drawing	Size	Q'ty
A	Nut		5/16"	8
B	Bolt		1/4"x45mm	6
C	Bolt		1/4"x75mm	8
D	Spring Washer		5/16"x12mm	22
E	Flat Washer		5/16"x19mm	22
F	Wrench		12x90mm	1
G	Screw		#4x38mm	24

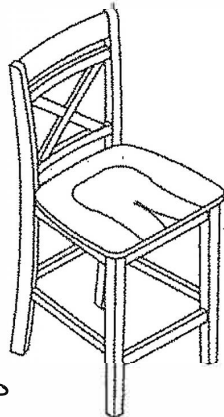

Step 1:

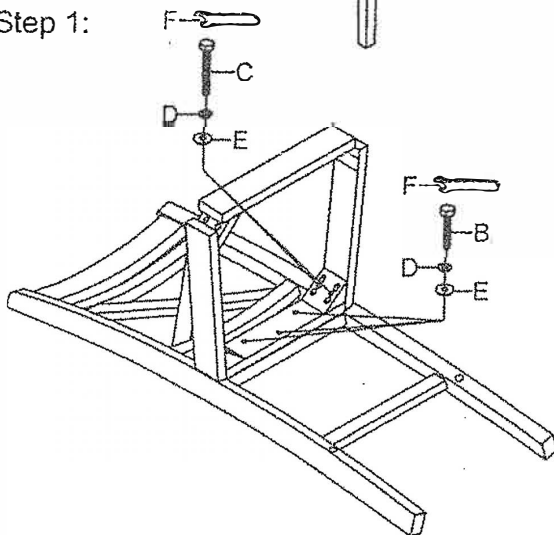

Step 2:

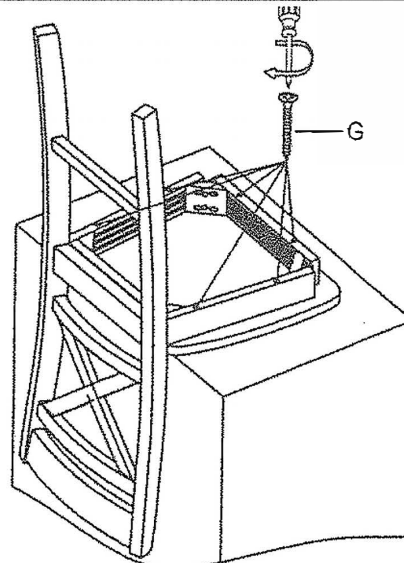

Step 3:

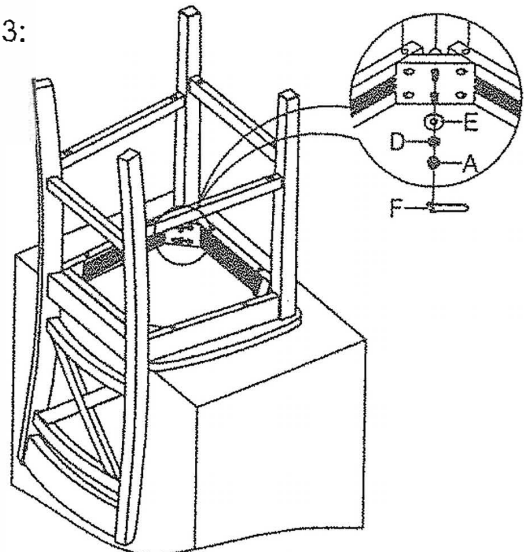

Step 4:

