



IN231000068V01_GL

84H-050V00



8

STEPS



0.5 HR

EN_IMPORTANT, RETAIN FOR FUTURE REFERENCE: READ CAREFULLY.

FR_IMPORTANT: A LIRE ATTENTIVEMENT ET À CONSERVER POUR CONSULTATION ULTÉRIEURE.

ES_IMPORTANTE, LEA Y GUARDE PARA FUTURAS REFERENCIAS.

PT_IMPORTANTE, RETER PARA REFERÊNCIA FUTURA: LEIA ATENTAMENTE.

DE_WICHTIG! SORGFÄLTIG LESEN UND FÜR SPÄTER NACHSCHLAGEN AUFBEWAHREN.

IT_IMPORTANTE! CONSERVARE IL PRESENTE MANUALE PER FUTURO RIFERIMENTO E LEGGERLO ATTENTAMENTE.

PARTS

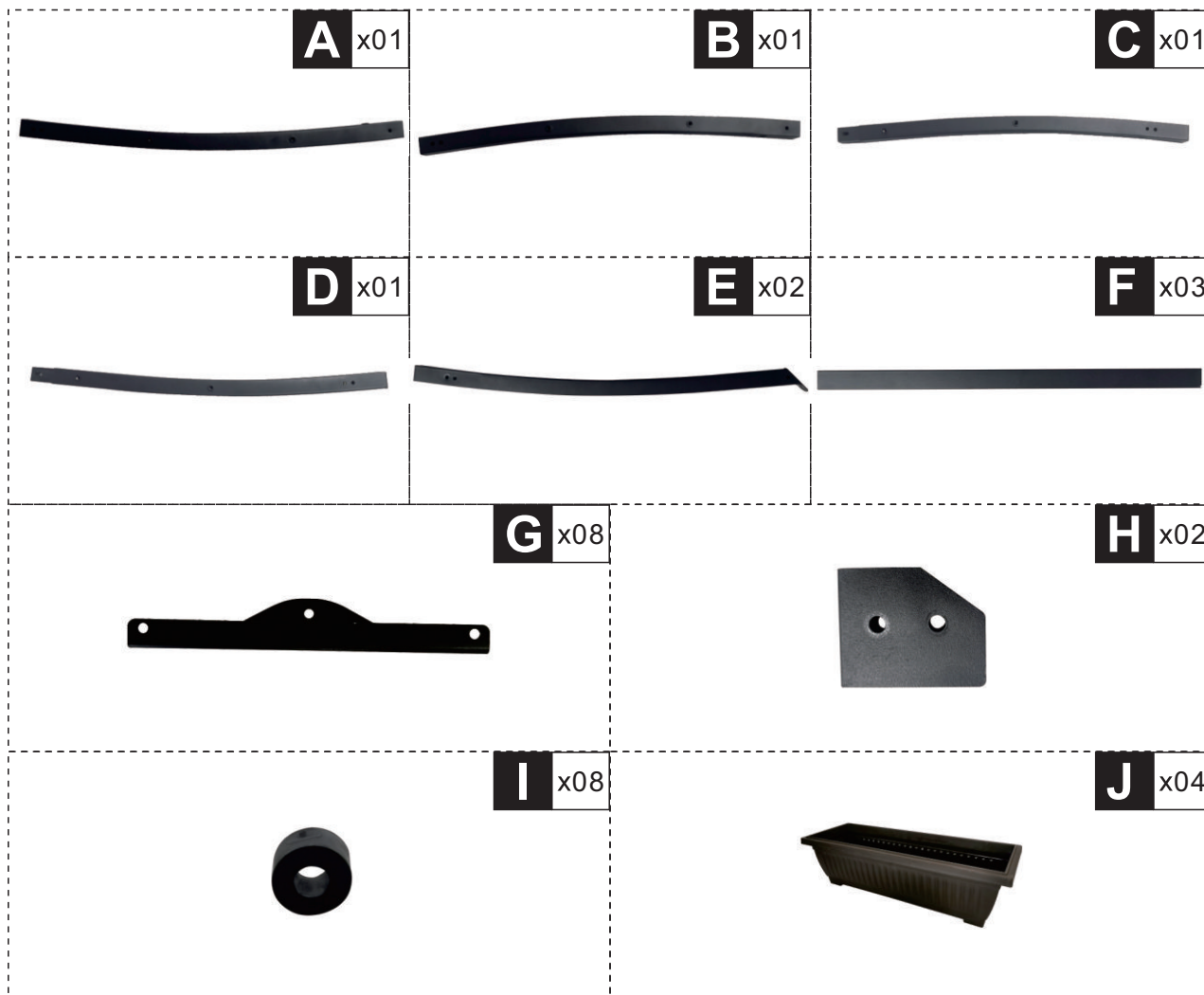

HARDWARE

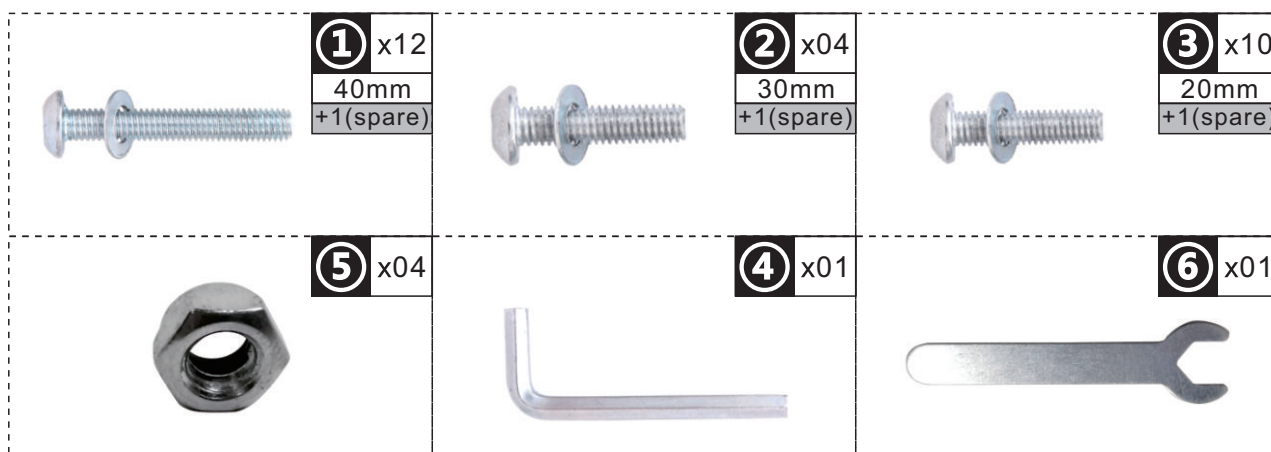

NOTE

EN Do not confuse similar screws.
FR Ne pas confondre des vis similaires.
ES No confunda tornillos similares.
PT Não confundir parafusos semelhantes.
DE Verwechseln Sie ähnliche Schrauben nicht.
IT Non confondere le viti simili.

EN_Step 1: Assemble C & D with F, as bottom frame. Direction same as below photo, the side have more holes of C & D should be inward.

FR_Étape 1 : Assembler C et D avec F, comme cadre inférieur. La direction est la même que sur la photo ci-dessous, mais le côté ayant le plus de trous de C et D doit être orienté vers l'intérieur.

ES_Paso 1: Ensamble C y D con F, como marco inferior. Dirección igual que la foto de abajo, el lado tiene más agujeros de C & D debe ser hacia adentro.

PT_Etapa 1: Montar C e D com F, como estrutura inferior. Direção igual à da fotografia abaixo, o lado com mais orifícios de C e D deve ficar para dentro.

DE_Schritt 1: Montieren Sie C und D mit F als unteren Rahmen. Richtung gleich wie unten Foto, die Seite haben mehr Löcher von C & D sollte nach innen sein.

IT_Fase 1: Assemblare C e D con F, come telaio inferiore. Come nella foto sottostante, il lato con più fori di C e D deve essere rivolto verso l'interno.

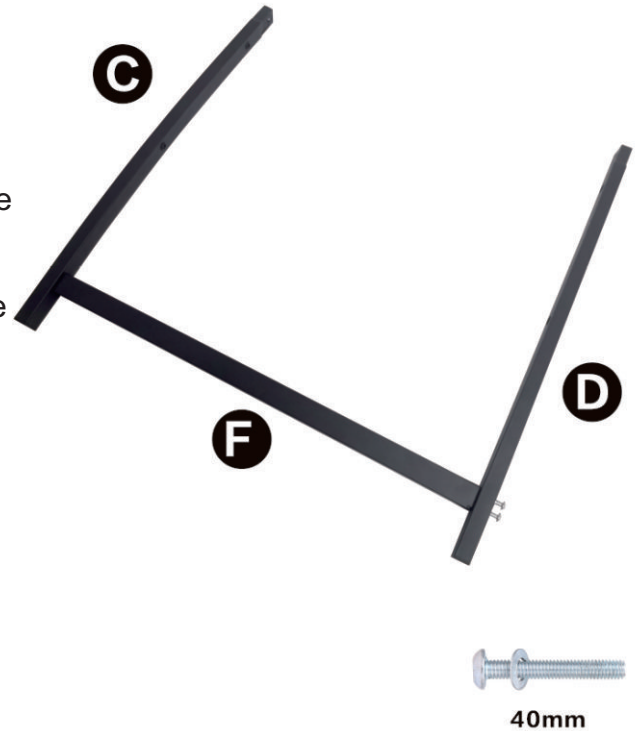

EN_Step 2: Assemble A & B with F, as top frame. Direction same as below photo, the side have more holes of A & B should be inward.

FR_Étape 2 : Assembler A et B avec F, comme cadre supérieur. La direction est la même que sur la photo ci-dessous, le côté ayant le plus de trous de A et B doit être tourné vers l'intérieur.

ES_Paso 2: Ensamble A y B con F, como marco superior. Dirección igual que la foto de abajo, el lado tiene más agujeros de A y B debe ser hacia adentro.

PT_Etapa 2: Montar A e B com F, como estrutura superior. Direção igual à da fotografia abaixo, o lado com mais orifícios de A e B deve ficar para dentro.

DE_Schritt 2: Montieren Sie A & B mit F, als oberen Rahmen. Richtung gleich wie unten Foto, die Seite haben mehr Löcher von A & B sollte nach innen sein.

IT_Fase 2: assemblare A e B con F, come telaio superiore. Come nella foto qui sotto, il lato con più fori di A e B deve essere rivolto verso l'interno.

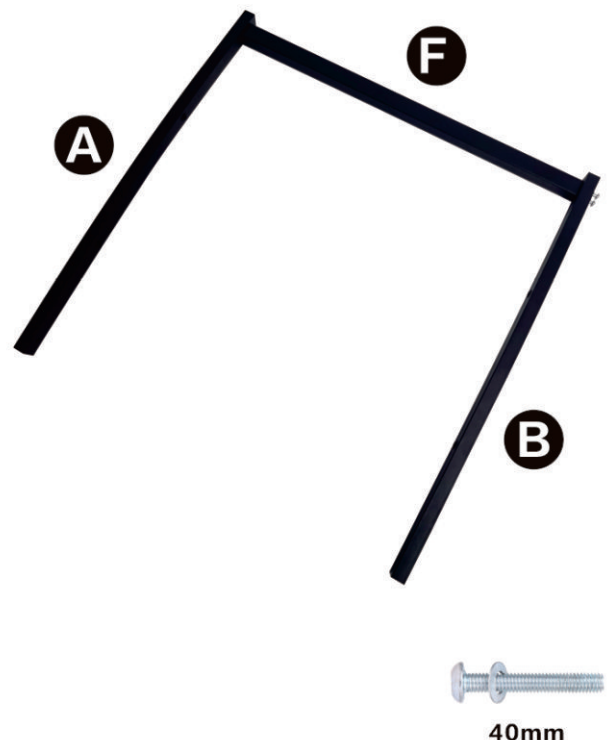

EN_Step3: Assemble 2pcs E with F, as rear frame.

FR_Étape 3 : Assembler les deux pièces E et F pour former le cadre arrière.

ES_Paso3: Ensamble 2pcs E con F, como marco trasero.

PT_Passo 3: Montar 2 peças E com F, como quadro traseiro.

DE_Schritt 3: Montieren Sie 2 Stück E mit F, als hinteren Rahmen.

IT_Fase 3: assemblare 2 pezzi E con F, come telaio posteriore.

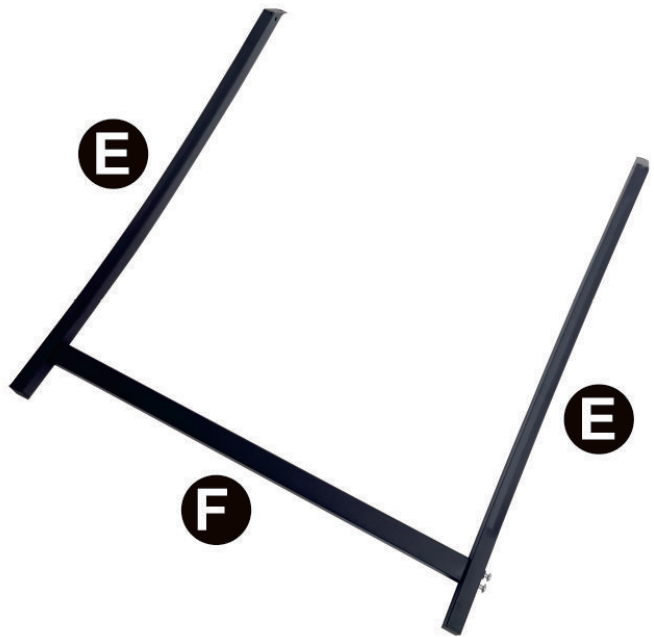

40mm

EN_Step 4: Assemble top frame with bottom frame. Do not tighten bolt and nut at this step.

FR_Étape 4 : Assembler le cadre supérieur avec le cadre inférieur. Ne pas serrer le boulon et l'écrou à cette étape.

ES_Paso 4: Ensamble el marco superior con el inferior. No apriete el perno y la tuerca en este paso.

PT_Passo 4: Montar a estrutura superior com a estrutura inferior. Não aperte o parafuso e a porca nesta fase.

DE_Schritt 4: Montieren Sie den oberen Rahmen mit dem unteren Rahmen. Ziehen Sie Schraube und Mutter in diesem Schritt noch nicht fest.

IT_Fase 4: Assemblare il telaio superiore con quello inferiore. In questa fase non serrare i bulloni e i dadi.

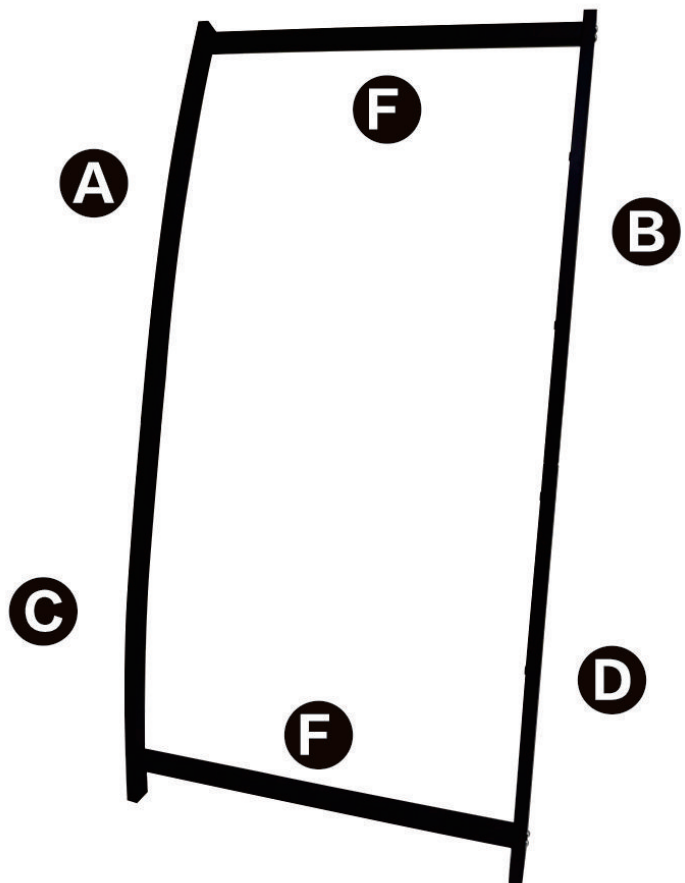

EN_Step5: Assemble rear frame on by using 20mm bolt.

FR_Étape 5 : Assembler le cadre arrière à l'aide d'un boulon de 20 mm.

ES_Paso 5: Montar el bastidor trasero con un tornillo de 20mm.

PT_Etapa 5: Montar o quadro traseiro com parafusos de 20 mm.

DE_Schritt 5: Montieren Sie den hinteren Rahmen mit einer 20-mm-Schraube.

IT_Fase5: assemblare il telaio posteriore utilizzando un bullone da 20 mm.

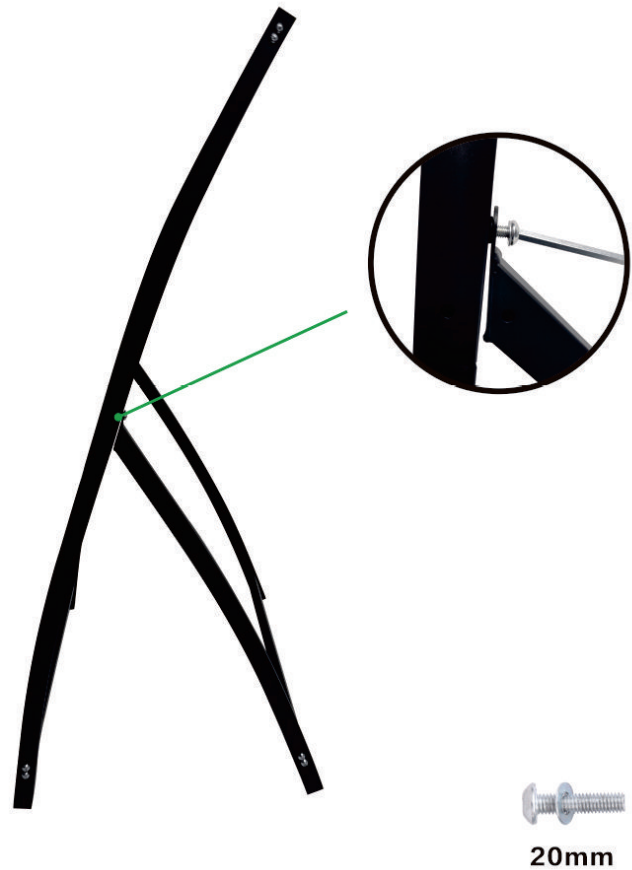

EN_Step 6: Assemble 2pcs H onto rack

FR_Étape 6 : Assembler les 2 pièces H sur le support

ES_Paso 6: Montar 2pcs H en la rejilla

PT_Etapa 6: Montar 2 peças H no suporte

DE_Schritt 6: 2 Stück H auf das Gestell montieren

IT_Fase 6: Assemblare i 2 pezzi H sulla rastrelliera

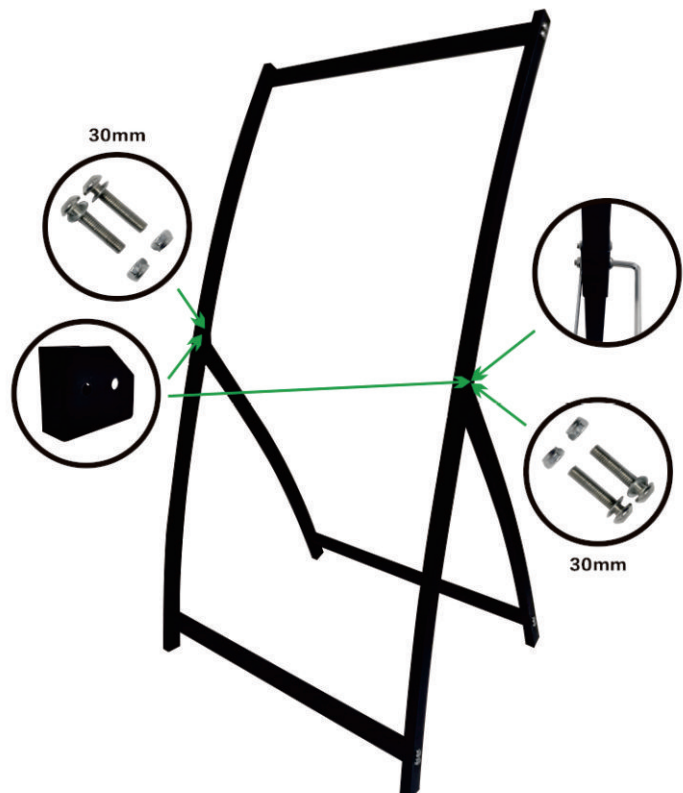

EN_Step 7: Assemble G onto rack.
FR_Étape 7 : Assembler G sur la grille.
ES_Paso 7: Montar la G en la rejilla.
PT_Etapa 7: Montar o G na grelha.
DE_Schritt 7: Setzen Sie G auf das Gestell.
IT_Fase 7: Assemblare G sulla rastrelliera.



EN_Step 8: Place plastic pots onto rack. The pot bottom have holes should face forward.
FR_Étape 8 : Placer les pots en plastique sur le support. Les trous du fond des pots doivent être orientés vers l'avant.
ES_Paso 8: Coloque las macetas de plástico en la rejilla. Los agujeros del fondo de la maceta deben mirar hacia delante.
PT_Etapa 8: Colocar os recipientes de plástico no suporte. Os orifícios do fundo do pote devem estar virados para a frente.
DE_Schritt 8: Stellen Sie die Kunststofftöpfe auf das Gestell. Die Löcher im Topfboden sollten nach vorne zeigen.
IT_Fase 8: collocare i vasi di plastica sulla rastrelliera. I fori sul fondo dei vasi devono essere rivolti in avanti.



If you have any questions, please contact our customer care center, Our contact details are below:

US

 001-877-644-9366

 customerservice@aosom.com

Imported by Aosom LLC
27150 SW Kinsman Rd Wilsonville, OR 97070 USA
MADE IN CHINA

If you have any questions, please contact our customer care center, Our contact details are below:

CA

 416-792-6088

 customerservice@aosom.ca

Imported by Aosom Canada Inc.
7270 Woodbine Avenue, Unit 307, Markham,
Ontario Canada L3R 4B9
MADE IN CHINA

Si vous avez la moindre question, veuillez contacter notre centre d'assistance à la clientèle, Nos coordonnées sont les suivantes:

 416-792-6088

 customerservice@aosom.ca

Importé par Aosom Canada Inc.
7270 Woodbine Avenue, unité 307,
Markham, Ontario Canada L3R 4B9
FABRIQUÉ EN CHINE

If you have any questions, please contact our customer care center, Our contact details are below:

UK

 0044-800-240-4004

 enquiries@mhstar.co.uk

IMPORTER ADDRESS:
MH STAR UK LTD
Unit 27, Perivale Park,
Horsenden lane South
Perivale, UB6 7RH
MADE IN CHINA

Si vous avez la moindre question, veuillez contacter notre centre d'assistance à la clientèle, Nos coordonnées sont les suivantes:

FR

 0033-1-84166106

 aosom@mhfrance.fr

Importé par/Fabricant/REP:
MH FRANCE
2 Rue Maurice Hartmann
92130 Issy Les Moulineaux
France
FABRIQUÉ EN CHINE

Wenn Sie Fragen haben, wenden Sie sich bitte an unser Kundendienstzentrum, Unsere Kontaktdaten stehen unten:

DE

 0049-0(40)-87408465

 service@aosom.de

ADRESSE DES IMPORTEURE/Hersteller/REP:
MH Handel GmbH
Wendenstraße 309
D-20537 Hamburg
Germany
IN CHINA HERGESTELLT

In caso di dubbio, si prega di contattare il nostro centro assistenza clienti, I nostri dettagli di contatto sono di seguito:

IT

 0039-0249471447

 clienti@aosom.it

IMPORTATO DA/Produttore/REP:
AOSOM Italy srl
Centro Direzionale Milanofiori
Strada 1 Palazzo F1
20057 Assago (MI)
P.I.: 08567220960
FATTO IN CINA

Si tiene alguna pregunta, comuníquese con nuestro Centro de Atención al Cliente, Nuestros datos de contacto son los siguientes:

ES

 0034-931294512

 atencioncliente@aosom.es

IMPORTADOR/Fabricante/REP:
SPANISH AOSOM, S.L.
C/ROC GROS, N°15.08550, ELS HOSTALETES DE
BALENYÀ, SPAIN.
B66295775
HECHO EN CHINA

Se tiver alguma dúvida, por favor contacte o nosso Centro de Atendimento ao Cliente, Os nossos dados de contacto são os seguintes:

 0034-931294512

 info@aosom.pt.

IMPORTADOR/Fabricante/REP:
SPANISH AOSOM, S.L.
C.ROC GROS N.15, 08550. ELS HOSTALETES DE
BALENYÀ
FEITO NA CHINA



FR

**DONNEZ
OU
RECYCLEZ**



OU



OU



ASSOCIATION

LIVRAISON

DÉCHÈTERIE

Adresses sur quefairedemesdechets.fr