

INSTRUCTION MANUAL ENCLOSED

ATTENTION

**IF YOU HAVE ANY PROBLEMS OR QUESTIONS, EMAIL OR CALL
CUSTOMER SERVICE BEFORE YOU RETURN THIS PRODUCT TO THE
STORE WHERE IT WAS PURCHASED.**

****When emailing Customer Service, please include your **Order Number** and **platform of purchase** in the email subject for quicker assistance.**

INSTRUCTION MANUAL ENCLOSED

OUTDOOR Club Chair

OUTDOOR Club CHAIR ASSEMBLY INSTRUCTION

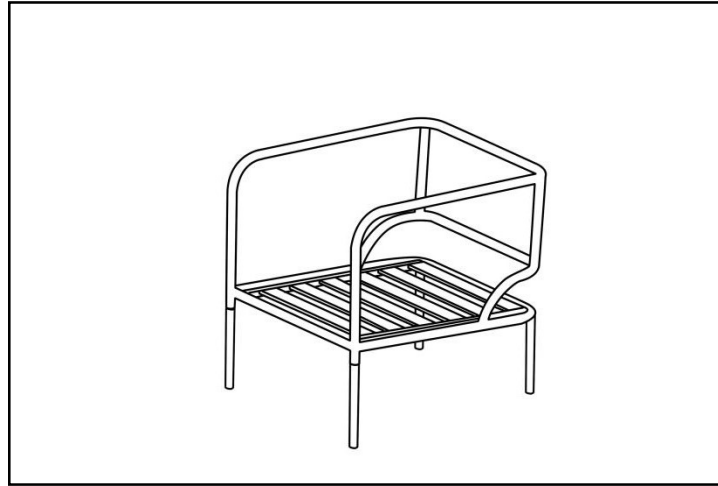

Part	PARTS LIST Description	Quantity
	<i>PARTS</i>	
A	Seat Frame	1
	<i>HARDWARE</i>	
B	Allen Key(comes from Box-1)	1
C	Feet caps	4
D	Allen Key	1
E	Nut	4
F	Chair leg	2
G	Bolt	4
H	Chair leg	2

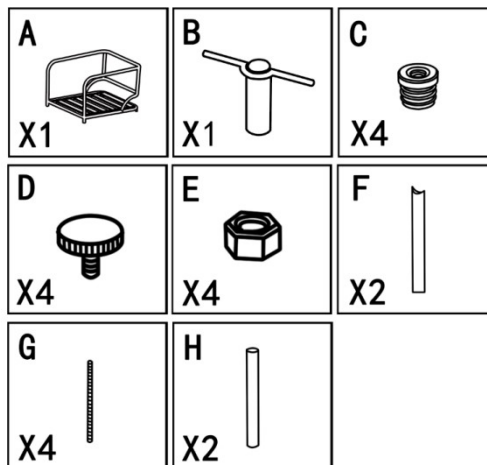

PLEASE READ AND FOLLOW ALL SAFETY TIPS

GETTING STARTED

1. Before assembly, CAREFULLY use scissors or utility knife to cut and unwrap all parts. Make sure you do not discard the hardware.
2. Make sure that you have all the parts listed. If you are missing any parts, please email us. Please identify the parts you need and model number. Make sure to include your name and address.
3. Please include your **Order Number** and **platform of purchase** in the email subject, and one of our customer service representative will get back to you.

Warm Tips:

1. The plastic covers on some metal parts are just for product protection. Please remove it before assembly.
2. Please follow the sequence of AI during assembly.
3. Do not tighten the screws until all of them are in right positions.

1. ①Fasten bolts(G),②Insert Chair leg(H),③,Use Allen Key(B) to fasten Bolts(E),
④Install feet cap(C) and levelers(D). (Photo 1)

STEP1

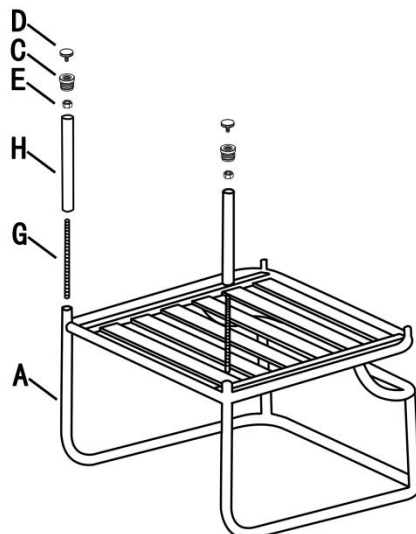

2. ①Fasten bolts(G),②Insert Chair leg(F),③,Use Allen Key(B) to fasten Bolts(E),
④Install feet cap(C) and levelers(D), turn over the Chair frame to the upright position carefully.

STEP2

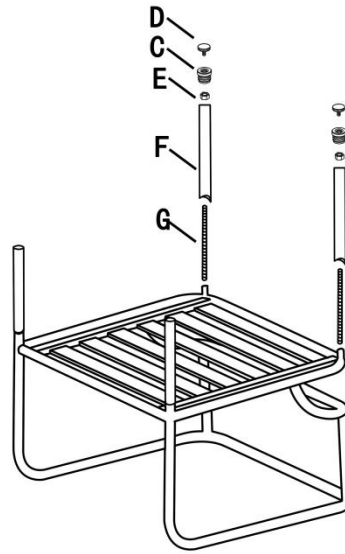

3. Follow the same instruction for the other club chairs.

Till now you have finished the whole assembly and enjoy your club chairs.

INSTRUCTION MANUAL ENCLOSED

OUTDOOR SIDE TABLE

OUTDOOR SIDE TABLE INSTRUCTION

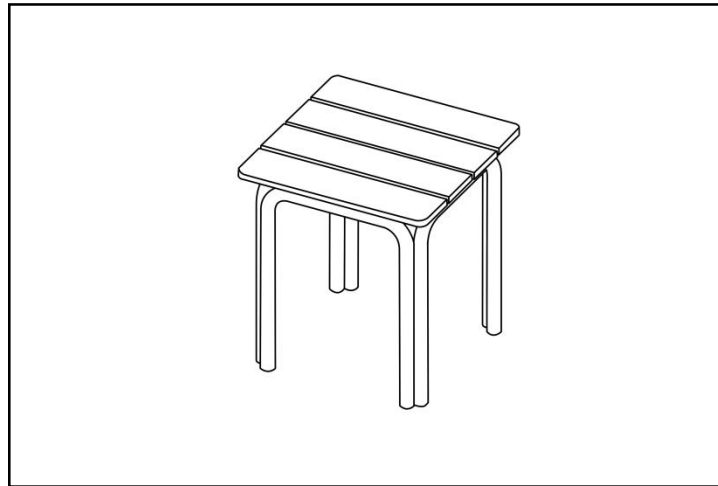

Part	PARTS LIST Description	Quantity
<i>PARTS</i>		
A	Table Feet	4
B	Table Top	1
<i>HARDWARE</i>		
C	Bolts(6X50mm)	8
D	Bolts(6X40mm)	4
E	Allen Key	2

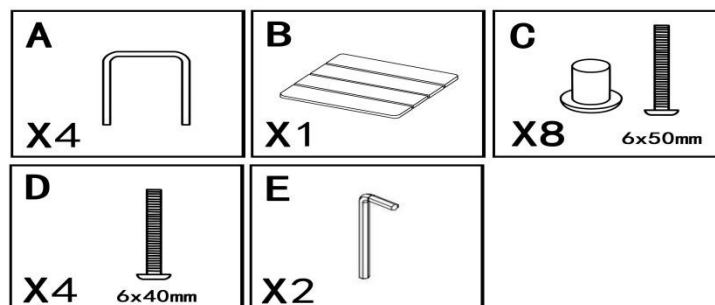

For Customer Service:

PLEASE READ AND FOLLOW ALL SAFETY TIPS

GETTING STARTED

1. Before assembly, CAREFULLY use scissors or utility knife to cut and unwrap all parts. Make sure you do not discard the hardware.
2. Make sure that you have all the parts listed. If you are missing any parts, please email us. Please identify the parts you need and model number. Make sure to include your name and address.
3. Please include your **Order Number** and **platform of purchase** in the email subject, and one of our customer service representative will get back to you.

Warm Tips:

1. The plastic covers on some metal parts are just for product protection. Please remove it before assembly.
2. Please follow the sequence of AI during assembly.
3. Do not tighten the screws until all of them are in right positions.

1.Position each Table Foot(A) by the pre-drilled threads. (Photo 1)

STEP1

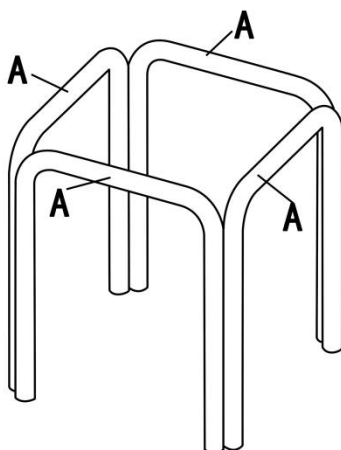

2. Use two Allen Key(E) to secured and fasten Bolts(C). Each foot should have 2 bolts fastened, total have 8 bolts fastened.(Photo 2)

STEP2

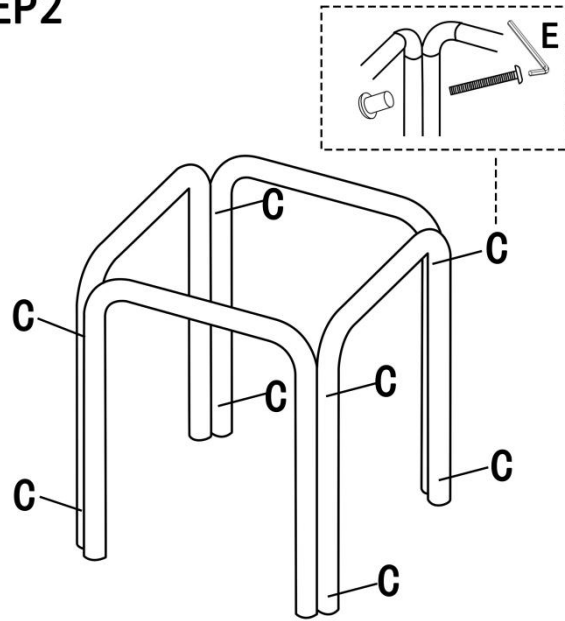

3. Put the Feet frame to the Table Top carefully, Use Allen Key(E) to fasten Bolts(D), Then turn over the Table to the upright position carefully. (photo 3)

STEP3

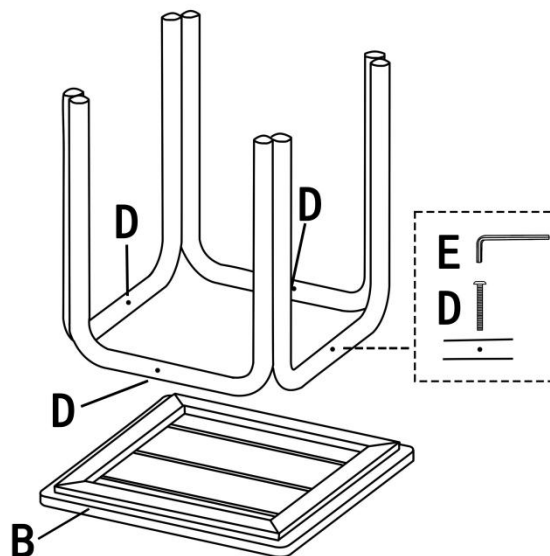

You have completed assembling the furniture – enjoy!