





ASSEMBLY MANUAL



WARNING

Manufacturer and seller expressly disclaim any and all liability for personal injury, property damage or loss whether direct, indirect, or incidental, resulting from the incorrect attachment, improper use, inadequate maintenance, or neglect of this product.

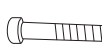
HARDWARE :

A×9  Φ8 Flat washer	B×9  Φ8 Lock washer	C×1  M8 Allen key	D×1  M8×55MM Shorter Screw	E×4  M8×60MM Medium Screw	F×4  M8×75MM Longer Screw
--------------------------------------------------------------------------------------------------------------	---------------------------------------------------------------------------------------------------------------	-------------------------------------------------------------------------------------------------------------	----------------------------------------------------------------------------------------------------------------------	---------------------------------------------------------------------------------------------------------------------	---------------------------------------------------------------------------------------------------------------------

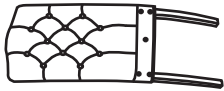
PARTS LIST

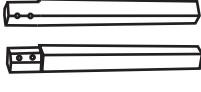
	G×1  Back
H×1  Seat	I×2  Front Legs

1

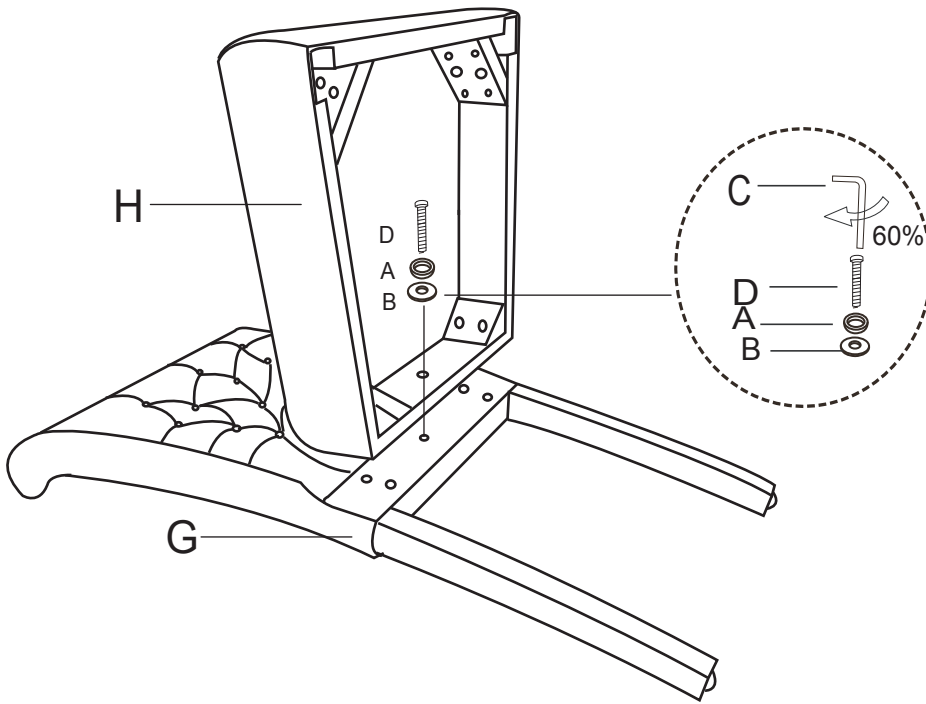

Put chair back on a clean flat surface.

Place seat pad against chair back as shown in diagram.

Secure center holes of the seat pad to chair back by using SHORTER

SCREW (D) with Washer (#A,B).

DO NOT FULLY TIGHTEN.

First HAND tighten then tightened using key up-to 60-80% only at this stage.

2

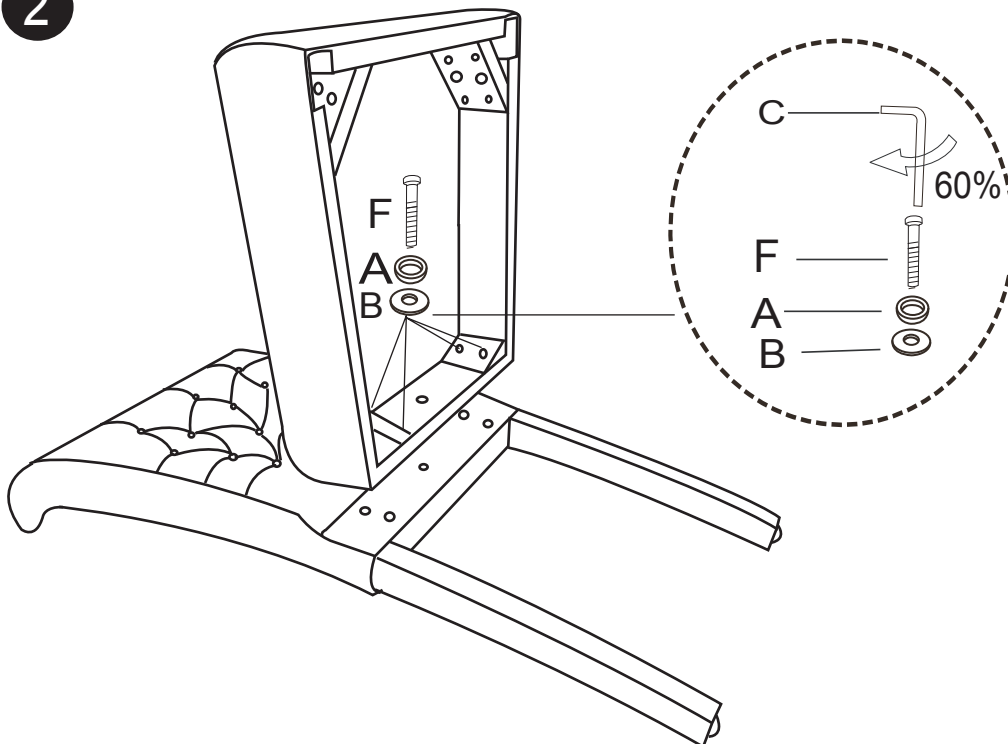

Secure both corner holes of the seat pad to the chair back by using

LONGER SCREWS (F) with washers (#A,B).

DO NOT FULLY TIGHTEN.
First HAND tighten All 4 screws TOGETHER at the same time.

Tightened up-to 60-80% using key only at this stage.

3

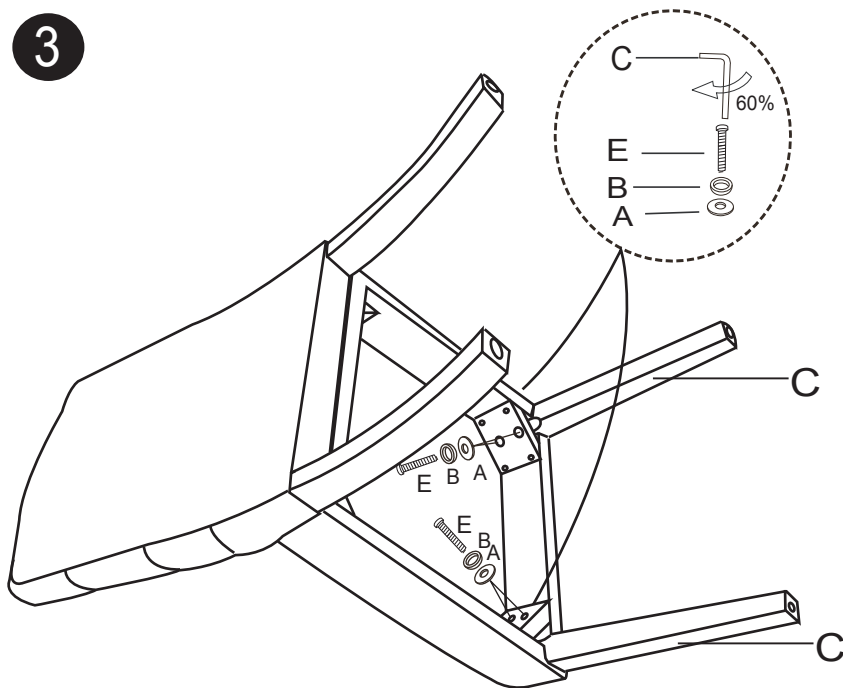

Align front legs in the seat pad as shown in the diagram.

Firm pressure is required to push the legs. use parts C,E,A,B, to secure Again

Secure both corner holes of the seat pad to the chair back by using screws MEDIUM SCREWS (E) with washers (#A,B).

DO NOT FULLY TIGHTEN. First HAND tighten All 4 screws TOGETHER at the same time.

Tightened up-to 60-80% using key only at this stage.

4

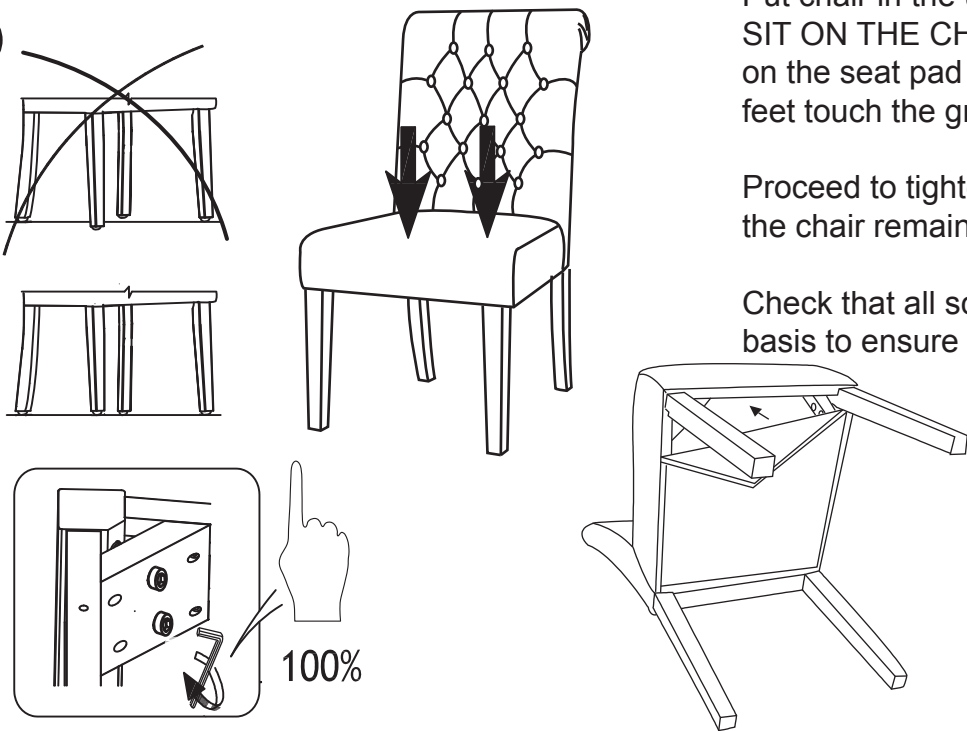

Put chair in the upright position and SIT ON THE CHAIR to press downwards on the seat pad ensuring that all 4 feet touch the ground and chair is leveled.

Proceed to tighten all screws making sure the chair remains level when tightening.

Check that all screws are tight on a regular basis to ensure chair remains level and secure.

5

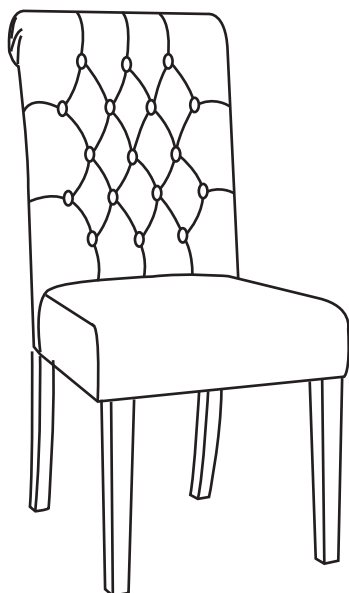

TROUBLESHOOT

One screw is in and other screw does not go in. Or Holes are not align.

1. Make sure to use 4 Medium screws (E) in Front Corner, 1 Shorter screw (D) in Back Center and longer screw (F) in the Corner Back.
2. Loosen the screw and then First HAND tightened All screws TOGETHER at the same time. then tightened to 60-80% at this stage only using key.
3. If both above steps are correct, please use Key to secure screws. It might be little stiff.

Chair Legs are not level or shorter legs.

If the screws are fully tightened. Loosen screws up-to 60%. Put chair in the upright position and SIT ON THE CHAIR to press downwards on the seat pad ensuring that all 4 feet touch the ground and are leveled. Tightened all one by one.

Assembly Notes

Do not fully tighten the Bolts (screws) when assembling the chair.

Tighten all bolts about halfway.

Carefully put the chair on flat surface.

Please put a heavy object or seat one adult on top of the Chair Body on top of the Chair Seat to pressure the chair leg for leveling.

Once All legs are levelled, tighten all the bolts fully.

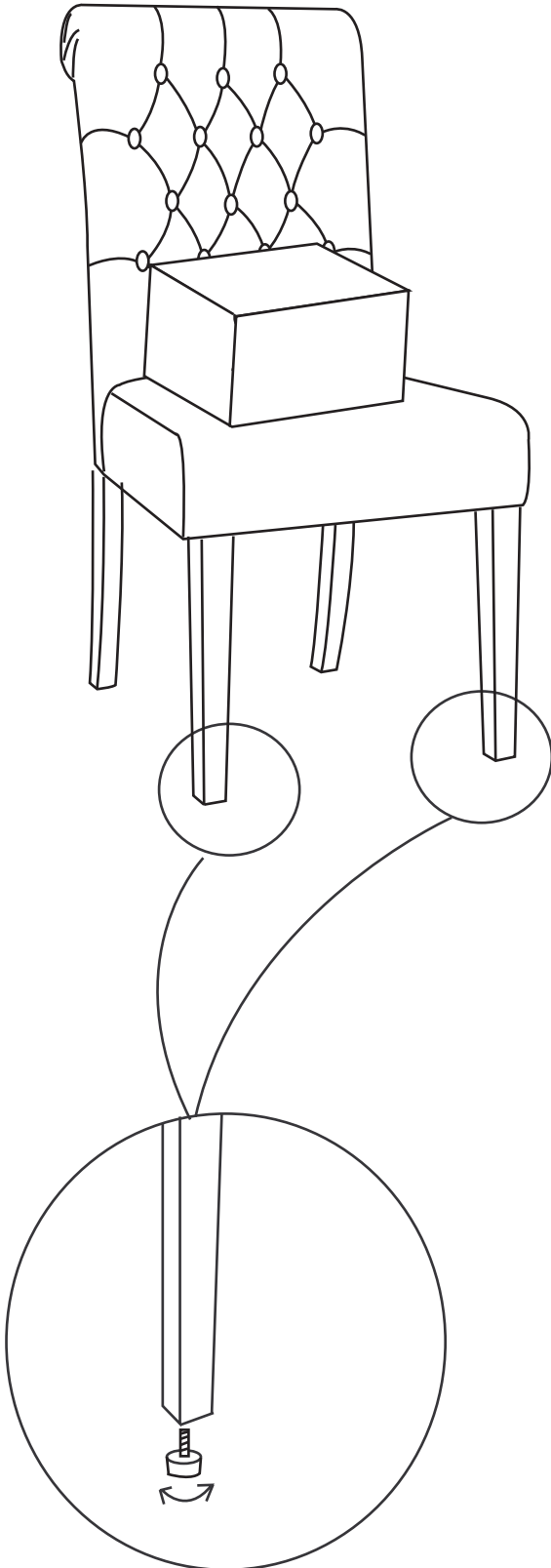

Dining Chairs – Assembly Troubleshooting Guide

The most important element of correct chair assembly is to tighten the bolts as directed. Prematurely tightening the bolts can lead to numerous issues and will lengthen the assembly time.

PROBLEM: Chair is unlevel or mis aligned

Cause 1:

Un-level chairs can occur if the bolts are fully tightened before all bolts are attached and legs are aligned.

There is a variance in the alignment of this chair to allow the chair to be assembled more easily.

Solution:

Half Loosen each bolt in the seat box (front legs, back corner blocks and back apron) until they are finger tight.

Place the chair upright on the floor. Sit in the chair for about 30 seconds. Once all legs are balanced,

carefully turn the chair upside down and tighten each bolt. The chair will now be level.

Also you can using adjustable feet to keep four legs level .