

Owner Manual



15 : 00

estimated
assembly time



2 or more

people required

Ok, let's
get started!



- Put on mood music!
- To prevent damage to product, use the clean side of package carton or rug as working surface.
- In the event of missing or damaged parts, delivery problems etc., please reach out to our team.
We will be happy to fix the problem!

care guide

- Clean regularly with a soft and dry cloth.
- To protect finish, avoid use of abrasive cleaners.
- Wipe up spills immediately. Please!



product parts



(A)
Tabletop
x1

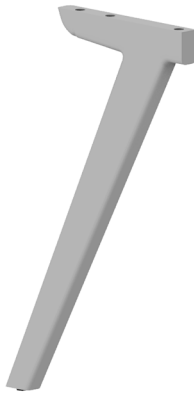

(B)
Table Legs
x4

what's included

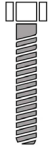

(C)-Bolt (8 x 60mm)
x12

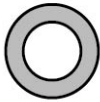

(D)- Washer (Ø8.5mm)
x12

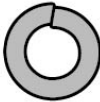

(E)-Lock Washer (Ø8.5mm)
x12

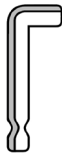

(F)- Allen Key
x1

- BS** Black Sticker
- RS** Red Sticker
- YS** Yellow Sticker
- GS** Green Sticker

assembly instructions

Friendly Tip: Take a deep breath going in. This may be a tricky part, but nothing too overwhelming. Just follow these steps to the T and the outcome will be worth it!



step 1:

Start by turning the table top (A) upside down on a flat surface. Align one of the table legs (B) with the given slots on the tabletop (A). Ensure the stickers on (A) match the stickers on (B).

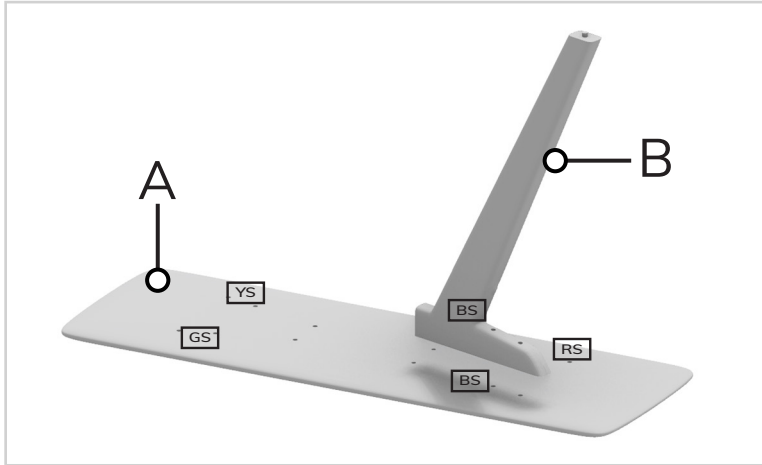

step 2:

Now, attach the table leg (B) by inserting washer (D), lock washer (E) and bolts (C). Tighten using allen key (F). Use the image below as reference.

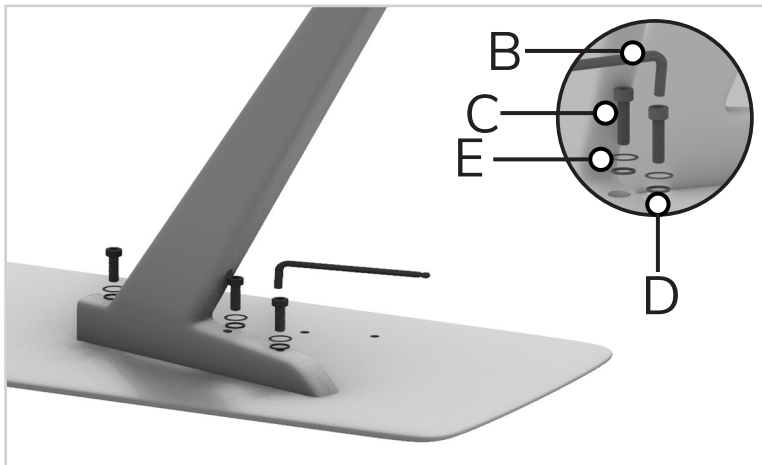

step 3:

Repeat steps 1 & 2 with the remaining legs. When done, flip the table upright.

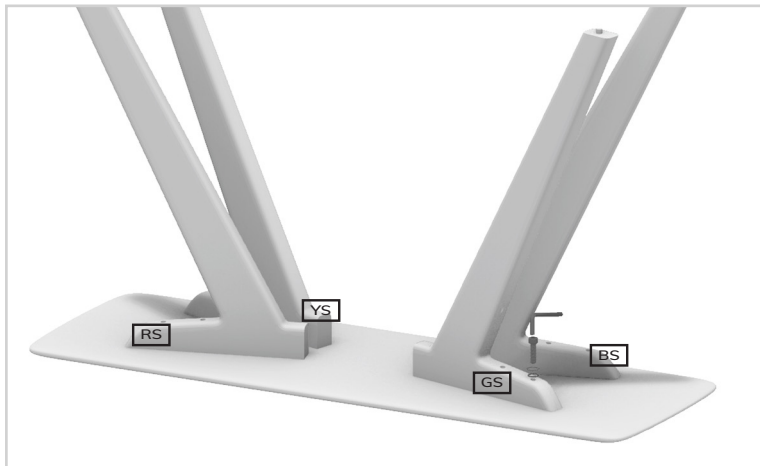

step 4:

If required, adjust the levellers according to the floor as shown in the image.





Voilà! Your table is now assembled and secure!
