



ASSEMBLY INSTRUCTIONS

INSTRUCTIONS D'ASSEMBLAGE / INSTRUCTIVO DE ARMADO

Ready to assemble, ready to be !

Prêt à être assemblé, prêt à être !

Listo para ensamblar, listo para ser !

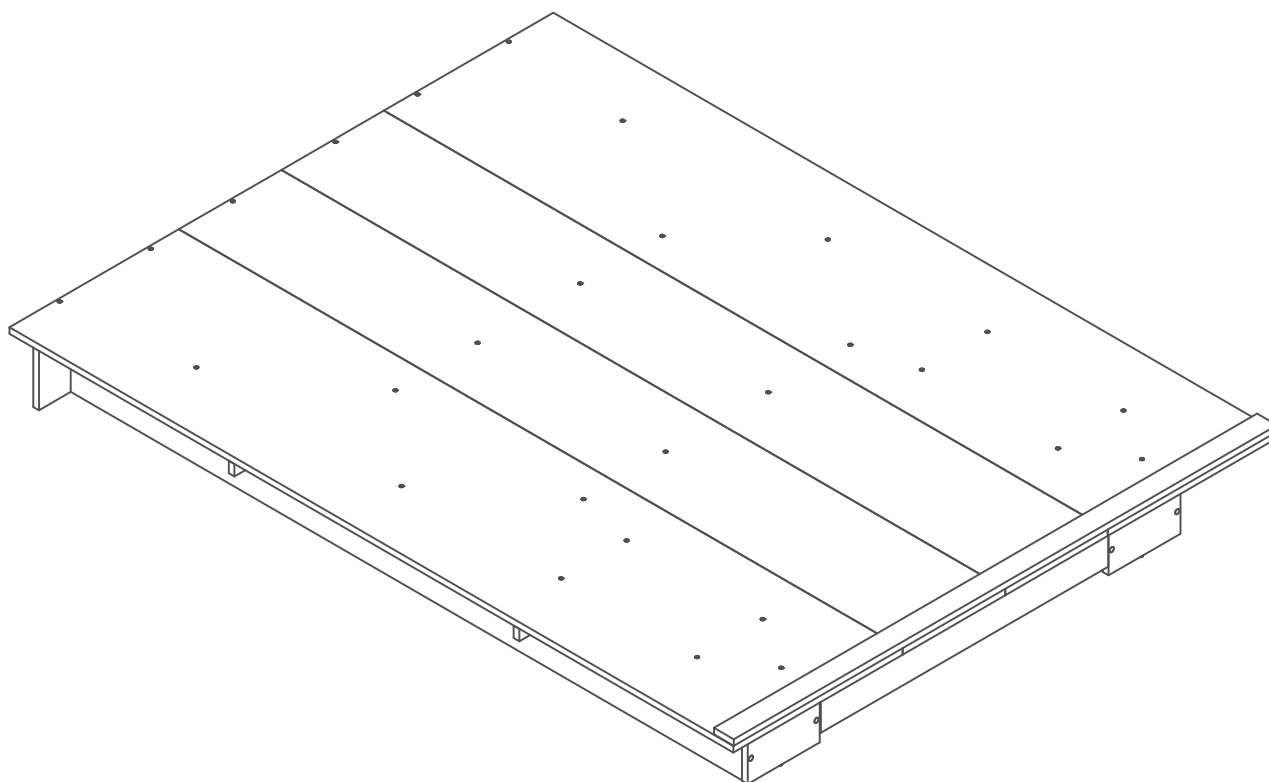

5-YEAR LIMITED WARRANTY

GARANTIE LIMITÉE DE 5 ANS / GARANTIA LIMITADA DE 5 AÑOS



Our furniture is like family to us. And we never turn our back on family.

Our commitment to our furniture -- and to you -- doesn't end the minute you've purchased the piece. We offer a 5-year warranty on all of our manufactured furniture pieces.

1. Furniture provides the original buyer with a warranty covering "defects" on furniture parts and workmanship for a period of 5 years from the date of purchase.

2. The word "defect" as used in this warranty is defined as any imperfection that may impair the intended use of the product.

3. This warranty is strictly limited to the repair or replacement of defective component parts, and excludes all other direct or indirect charges and expenses up to the limit permitted by law in your state/province.

4. In the case of a discontinued part or product, Furniture promises to reimburse the value of that part or product.

5. If a replacement part is unavailable, Furniture's liability to the buyer will not exceed the production cost of the part in question.

6. This warranty only applies under conditions of normal domestic use. It does not cover defects

resulting from commercial use, intentional damage, negligence, abuse, product modification, accidents, exposure to the elements, or maintenance that does not comply with the guidelines in this guide.

7. To honor this warranty, Furniture reserves the right to verify the grounds of any request and to ask for the original buyer's proof of purchase.

8. This warranty is only valid on purchases made at authorized

9. This warranty defines the limits of Furniture's liability, and entitles the original buyer to specific rights. Any warranty defined by law in your state/province is limited to a period of 5 years. If the law in your state/province prohibits this restriction, then it does not apply.

10. Furniture will not reimburse defective furniture, but will replace it with an item of equivalent value.

Nos muebles font partie de la famille. Et la famille, c'est pour la vie. Notre engagement envers nos produits et envers vous ne prend pas fin au moment de l'achat. Nous offrons une garantie de 5 ans sur tous les produits que nous fabriquons.

1. garantit à l'acheteur original, pour une période de 5 ans à partir de la date d'achat, toutes les composantes des meubles contre les « défauts » de matériaux et de main- d'oeuvre.

2. Le mot « défaut » utilisé dans cette garantie signifie une imperfection pouvant altérer l'utilité pour laquelle le produit est destiné.

3. Cette garantie se limite strictement à la réparation ou au remplacement des pièces composantes défectueuses. Cette garantie exclut tous les autres frais et dépenses directs ou indirects et ce, jusqu'à la limite permise par la législation en vigueur dans votre province/état.

4. Dans le cas d'une réclamation concernant un produit ou une pièce discontinuée, Meubles South Shore® s'engage à rembourser la valeur du produit ou de la pièce en question.

5. À défaut de pouvoir fournir la pièce de remplacement, la responsabilité de ne peut excéder la valeur équivalente au coût de production de la pièce en litige.

6. Cette garantie s'applique sous des conditions d'usage domestique normal et ne couvre pas les défauts pouvant résulter

d'un usage commercial, de dommages intentionnels, de la négligence, de l'usage abusif, de modifications personnelles, d'un accident, de l'exposition aux éléments ou d'un entretien ne respectant pas les conseils décrits dans ce guide.

7. Comme condition pour fournir une pièce de remplacement, e réserve le droit de vérifier le fondement de la requête, de même que d'exiger la preuve d'achat de l'acheteur original.

8. Cette garantie n'est valide que si et seulement si l'achat a été effectué chez un marchand autorisé par

9. Cette garantie définit les limites de la responsabilité de donne à l'acheteur original des droits spécifiques. Toute garantie législative prévalant dans votre lieu de résidence est limitée à une période de 5 ans. Si cette restriction n'est pas permise par la législation de votre lieu de résidence, elle ne s'applique pas.

10. ne remboursera pas un meuble défectueux, mais le remplacera par un autre de valeur équivalente.

Nuestros muebles son como una familia para nosotros y la familia, es para toda la vida.

Nuestro compromiso con nuestros muebles y con usted no termina al momento de la compra. Ofrecemos una garantía de 5 años en todos nuestros productos fabricados.

1. garantizan al comprador original, por un periodo de 5 años a partir de la fecha de compra, todas las piezas que componen el mueble contra los «defectos» de material y mano de obra.

2. La palabra «defecto» utilizada en esta garantía se define como toda imperfección que pueda alterar la utilidad para la cual se destina el producto.

3. Esta garantía se limita estrictamente a la reparación o reemplazo de las piezas que tengan componentes defectuosos. Esta garantía no incluye cualquier gasto directo o indirecto hasta el límite permitido por la legislación vigente en su lugar de residencia.

4. En el caso de una reclamación referente a un producto o pieza discontinuada, compromete a reembolsar el valor del producto o pieza en cuestión.

5. A falta de poder suministrar la pieza de repuesto, la responsabilidad de no puede exceder el valor equivalente al costo de producción de la pieza en litigio.

6. Esta garantía se aplica bajo las condiciones de uso doméstico normal y no cubre los defectos que puedan resultar de un

uso comercial, daños intencionales, negligencia, uso abusivo, modificaciones personales, un accidente, exposición a los elementos y mantenimiento sin respetar los consejos que se describen en este instrucción.

7. Como condición para suministrar una pieza de repuesto, e reservan el derecho de verificar el fundamento de la solicitud, así como de exigir la prueba de compra del comprador original.

8. Esta garantía sólo será válida si la compra se efectuó en una autorizado por

9. Esta garantía define los límites de la responsabilidad de South Shore® y otorga el comprador original los derechos específicos. Cualquier garantía legislativa que prevalece en su lugar de residencia está limitada a un periodo de 5 años. Si esta restricción no está permitida por la legislación de su lugar de residencia, ésta no se aplica.

10. no hará ningún reembolso por muebles defectuosos, pero le enviará uno de valor equivalente.

1

Let's get handy!

Mettons-nous au travail ! / ¡ Vamos a ponernos prácticos !

01

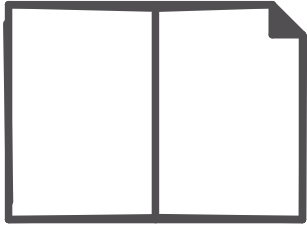

02

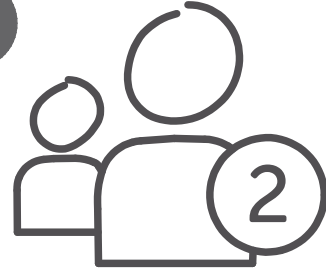

03

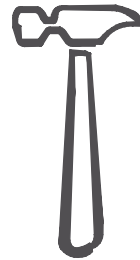
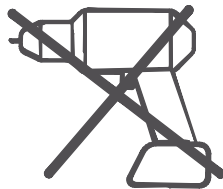

04

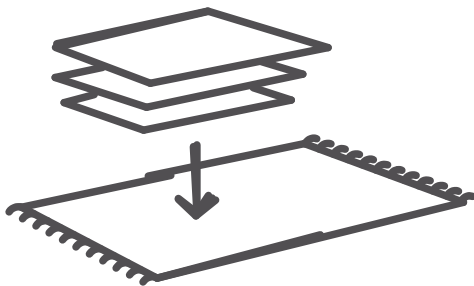

05

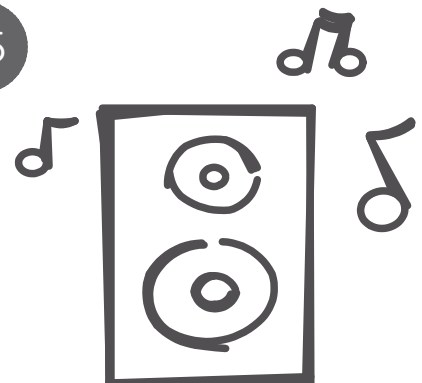

2

Collect the pieces together

Rassembler les morceaux ensemble

Poner las piezas juntas

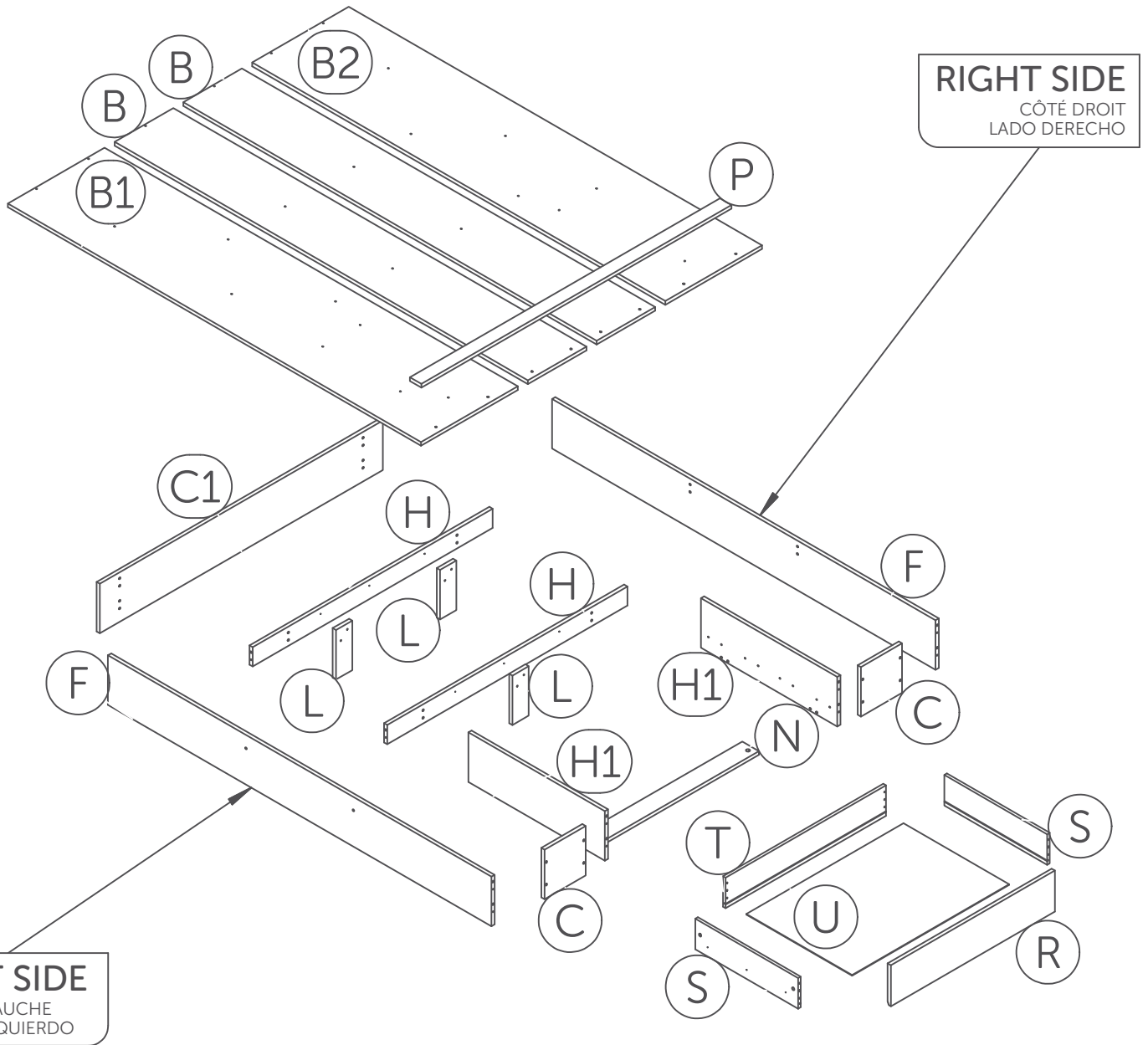
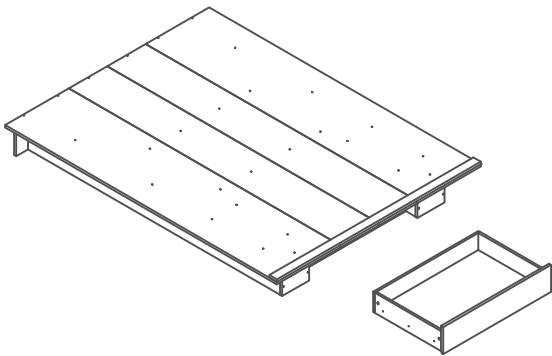

The image may differ depending on model
L'image peut différer selon le modèle
La imagen variar dependiendo del modelo

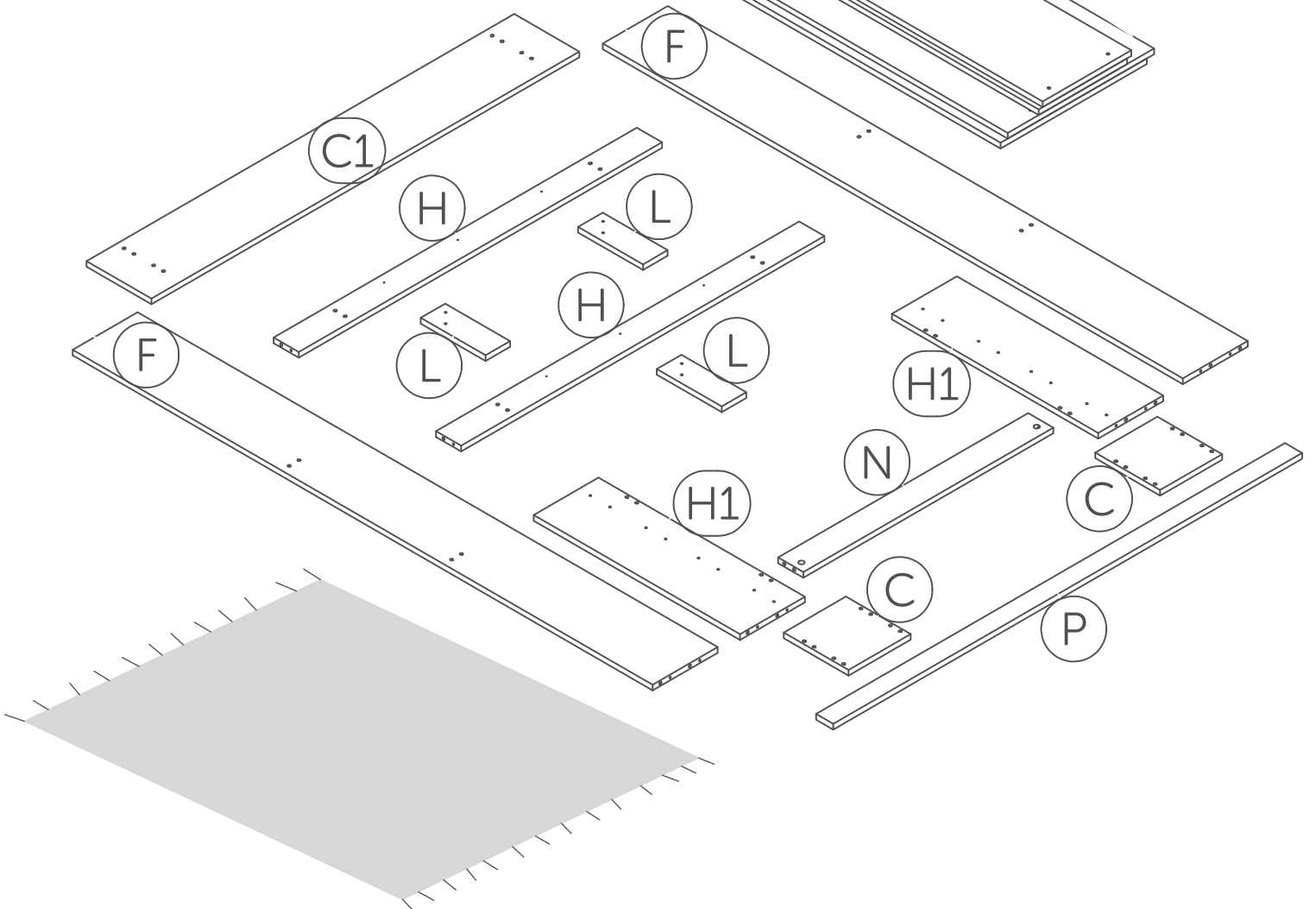
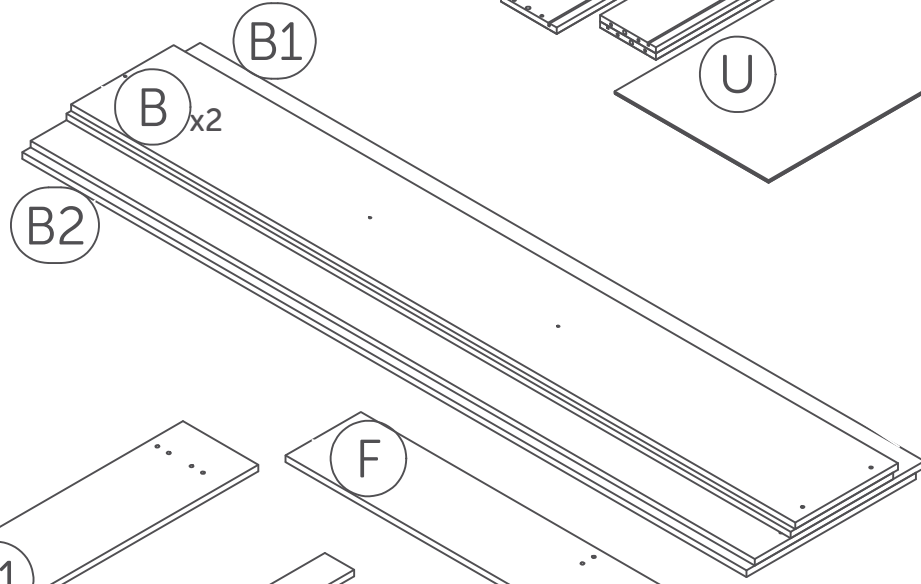
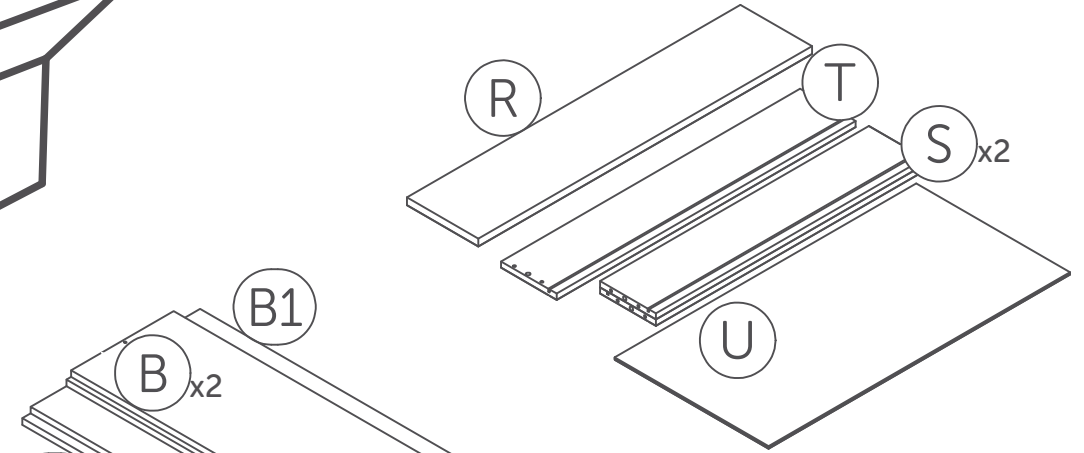
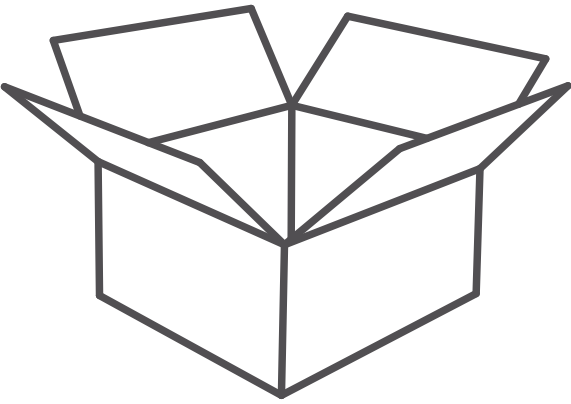

3

Collect the hardware

Rassembler la quincaillerie / Reunir los artículos de ferretería

1 : 1



Full scale
Taille réelle
De tamaño real

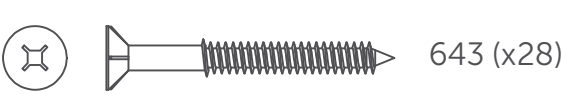
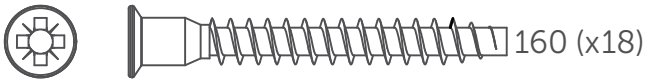
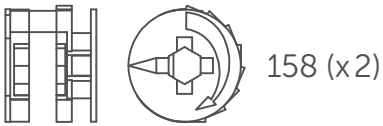
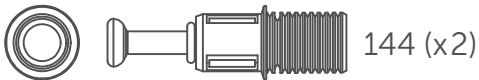

Or
Ou
O

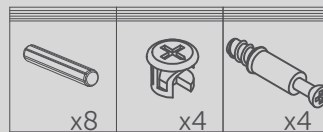
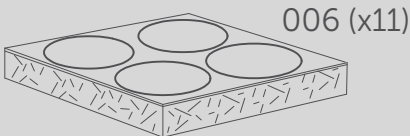
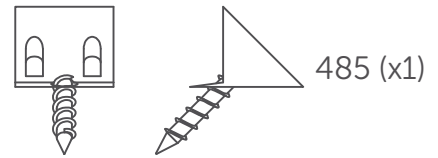
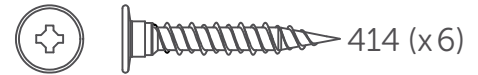
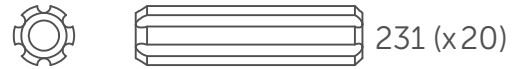
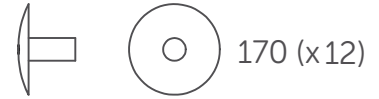
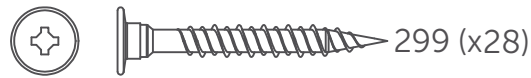

For drawers only/Pour tiroir seulement/
Solamente para cajones

Z-01 (X2)

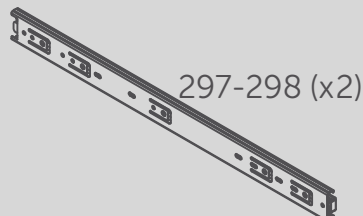
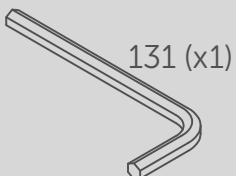

*Hardware package may have spare parts.
*Le sac de quincaillerie peut contenir des pièces de remplacement.
*La bolsa de herraje puede contener piezas adicionales de repuesto.

4

Things to remember for assembly

À retenir lors de l'assemblage / A recordar durante el ensamblaje

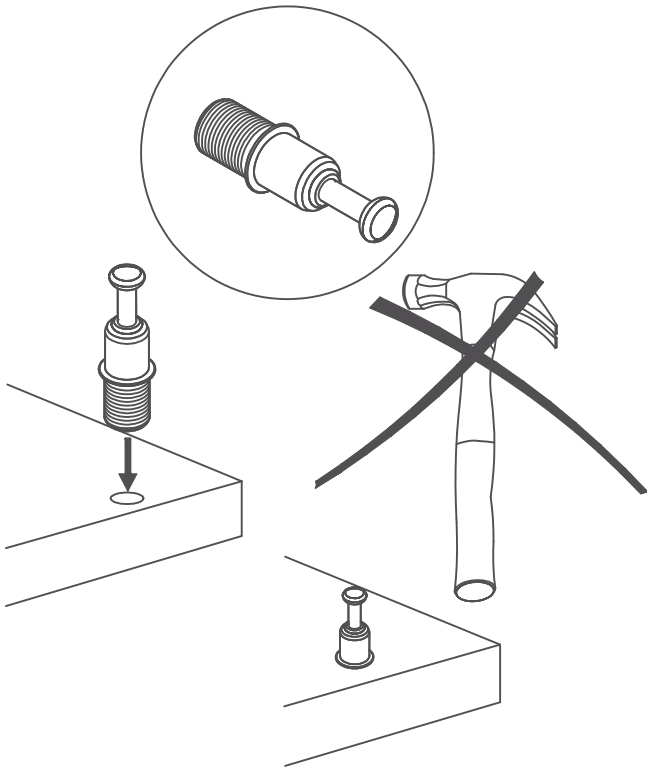

To remove: Twist and pull
Pour enlever: Tourner et tirer

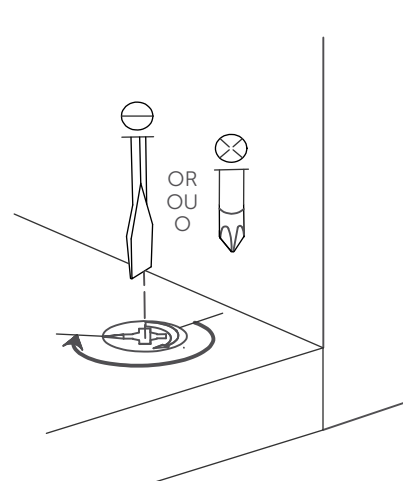
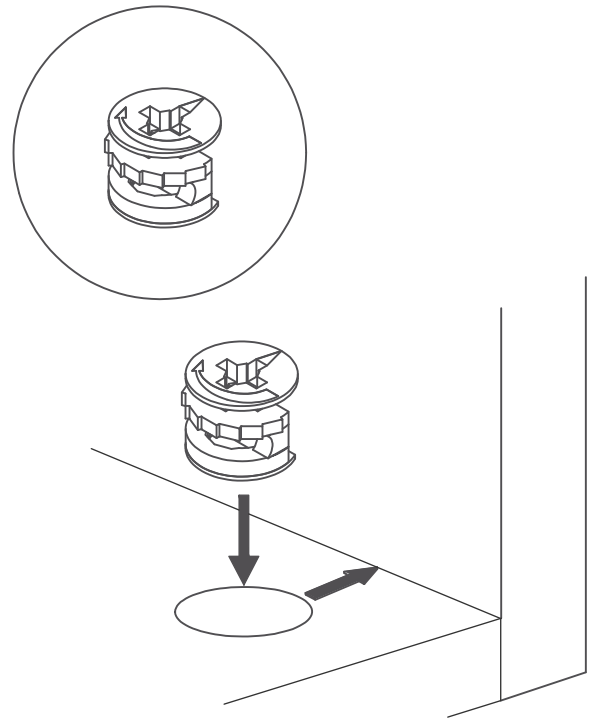
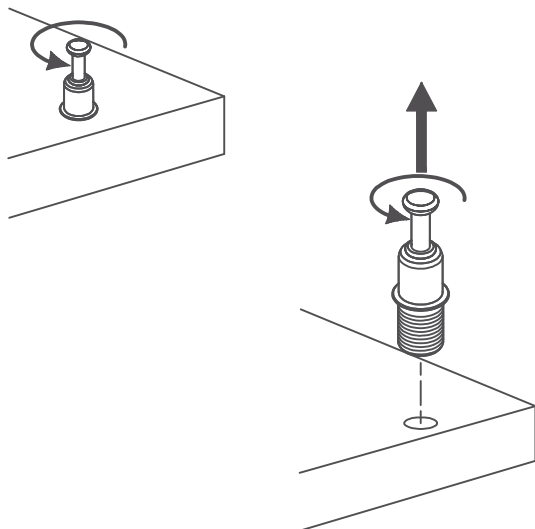

Screw pass the half way point
Visser plus qu'un demi tour

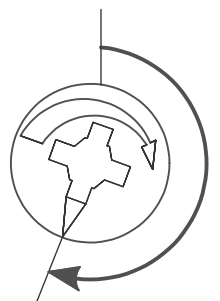

5

Separate the drawers slide.
Séparer la coulisse.
Saparar la corredera.

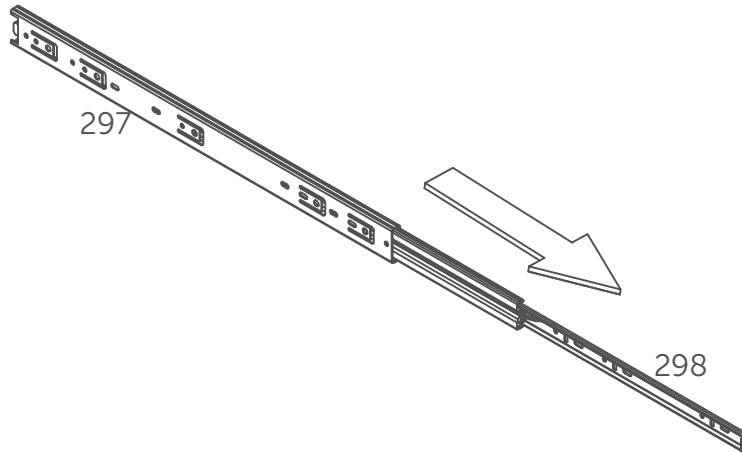
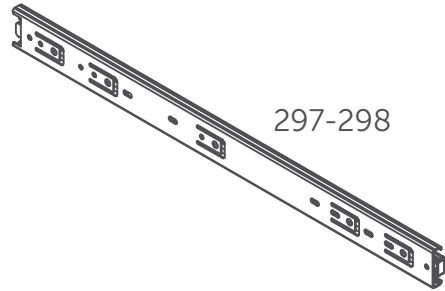

5.1

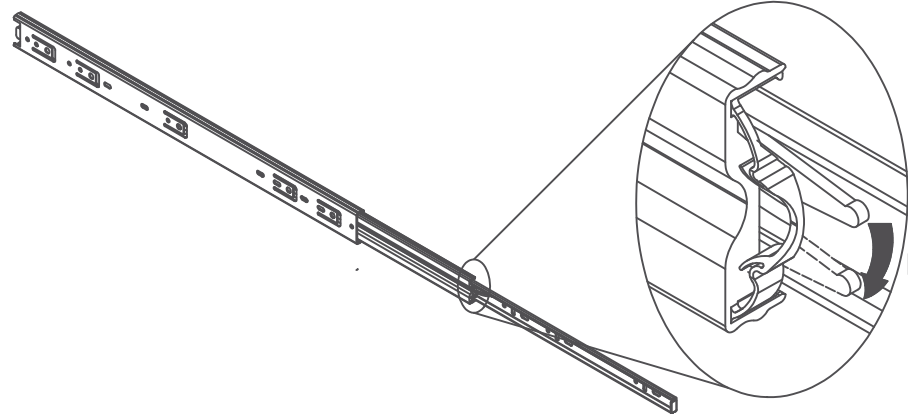

5.2

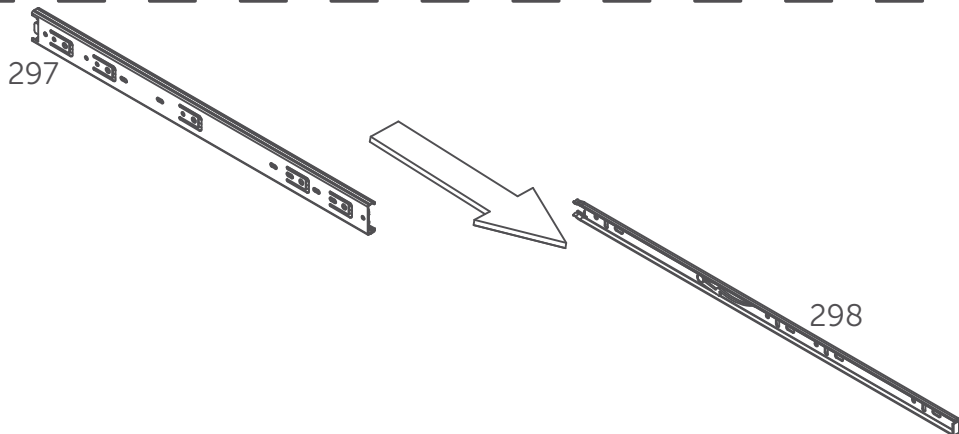

5.3

6

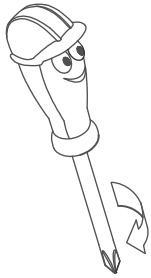
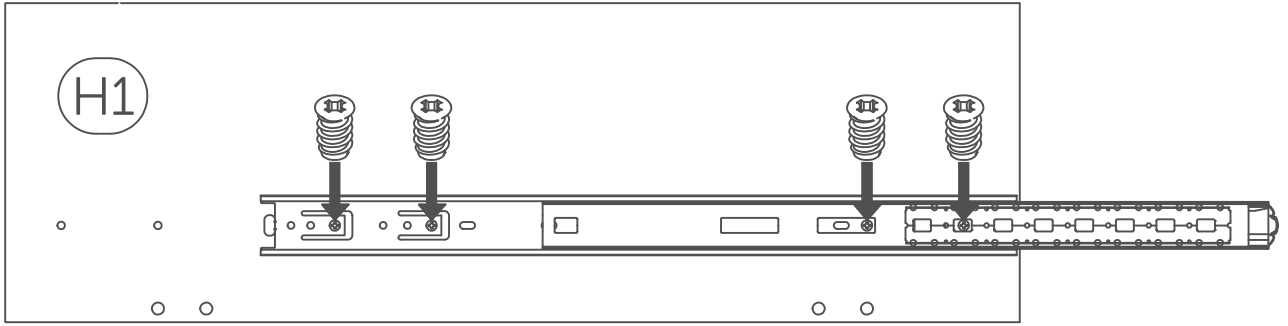

 092 (x8)

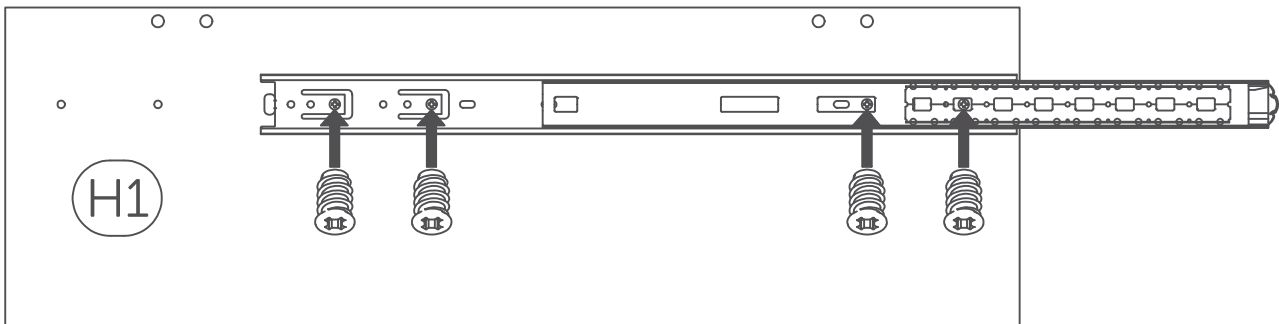
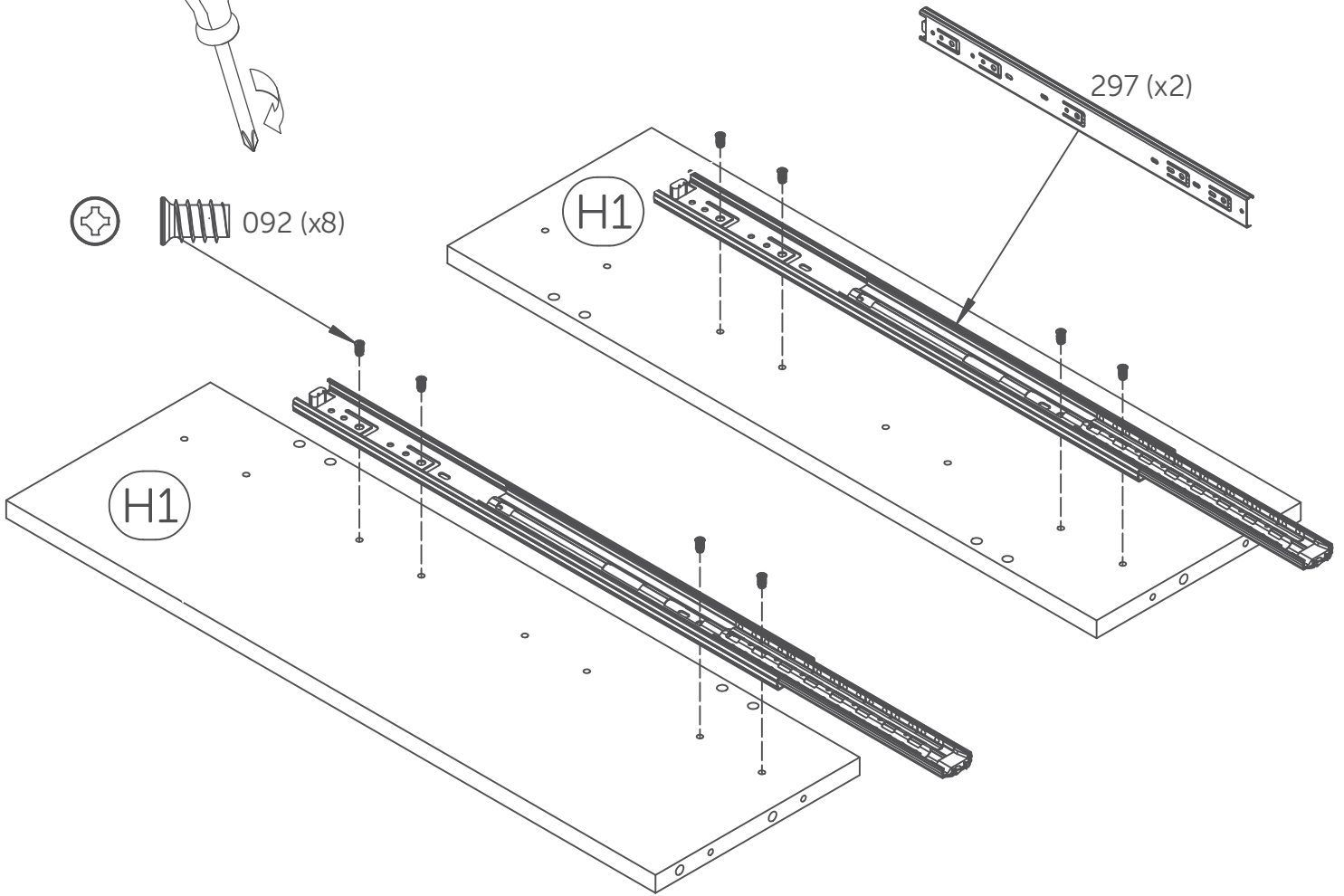

7

7.1

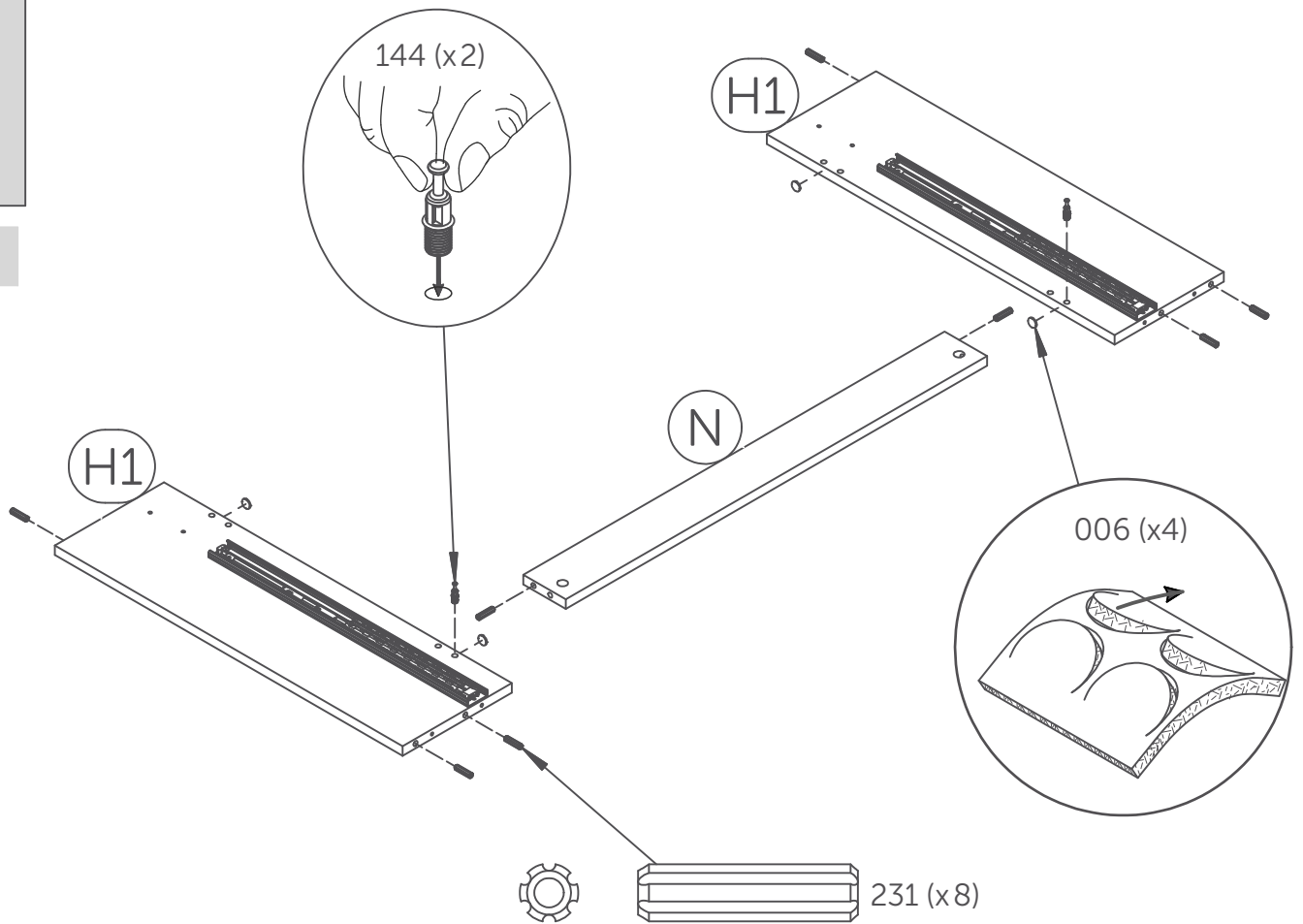

7.2

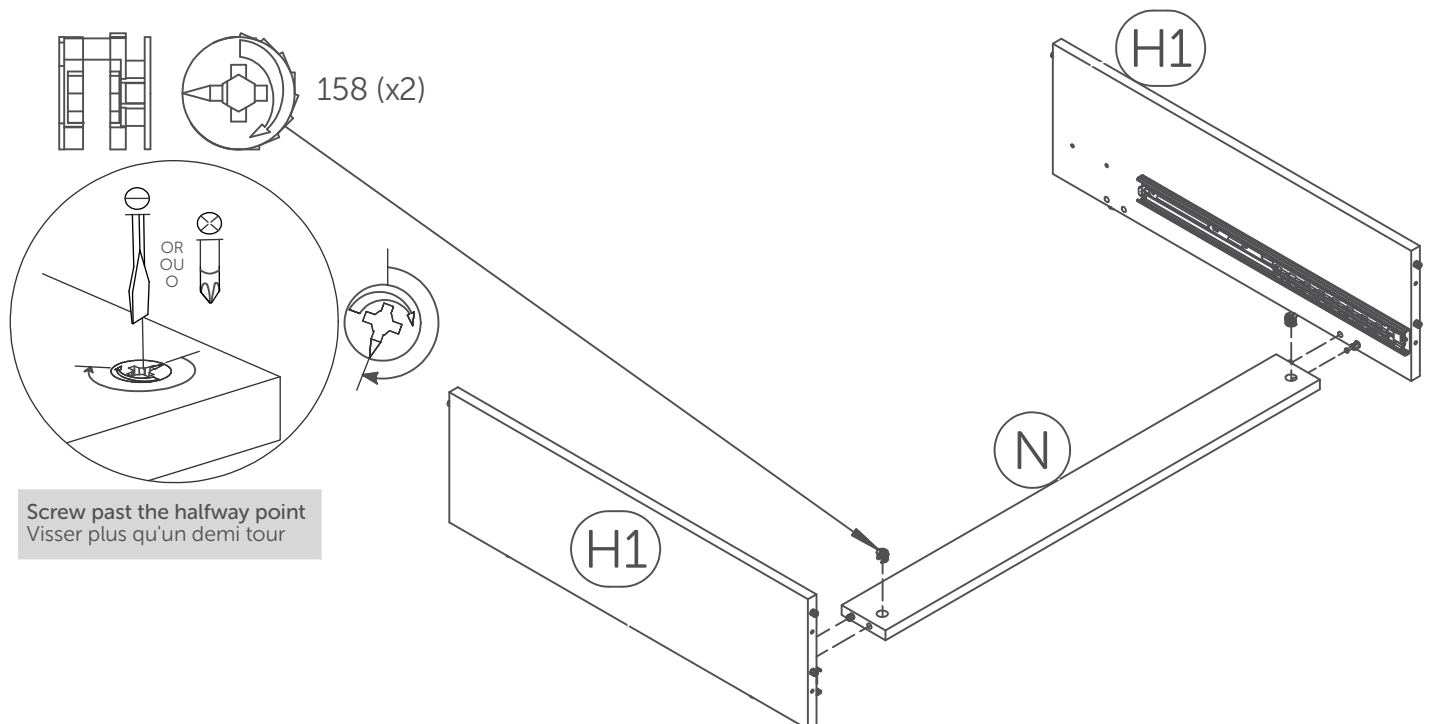

8

8.1

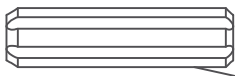
  231 (x4)

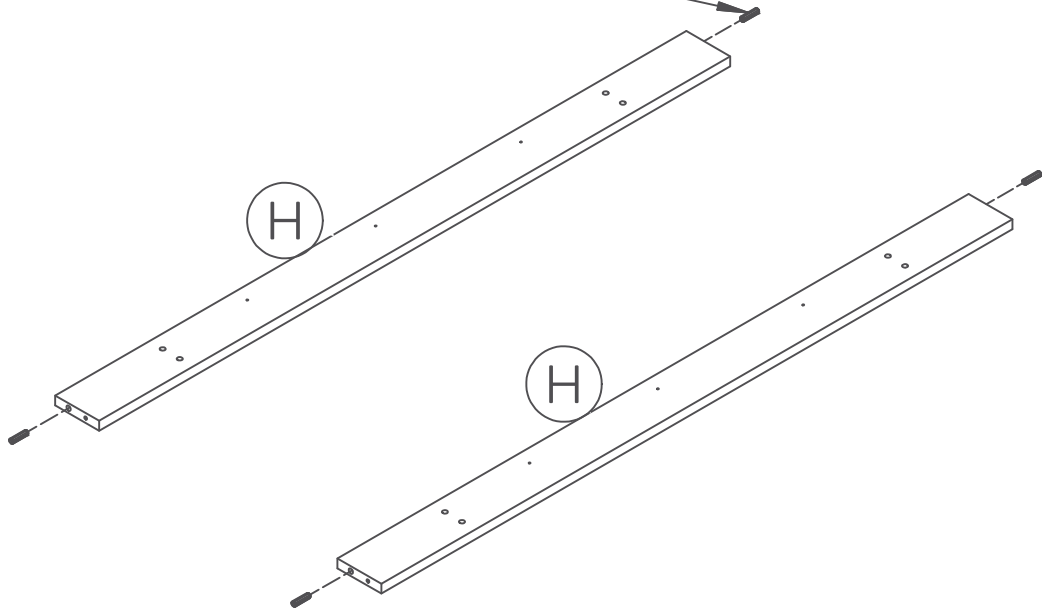

8.2

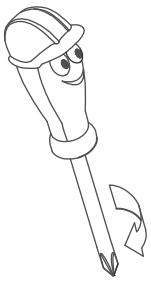

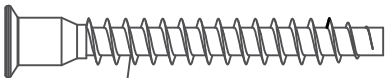
  160 (x2)

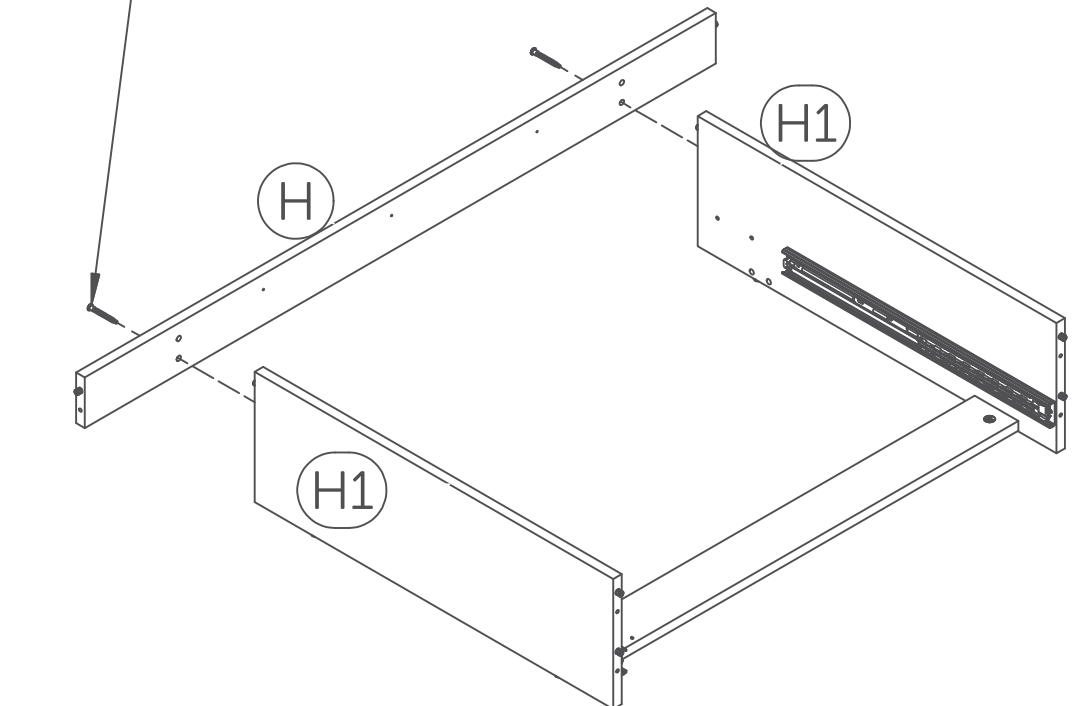

9

9.1



231 (x8)

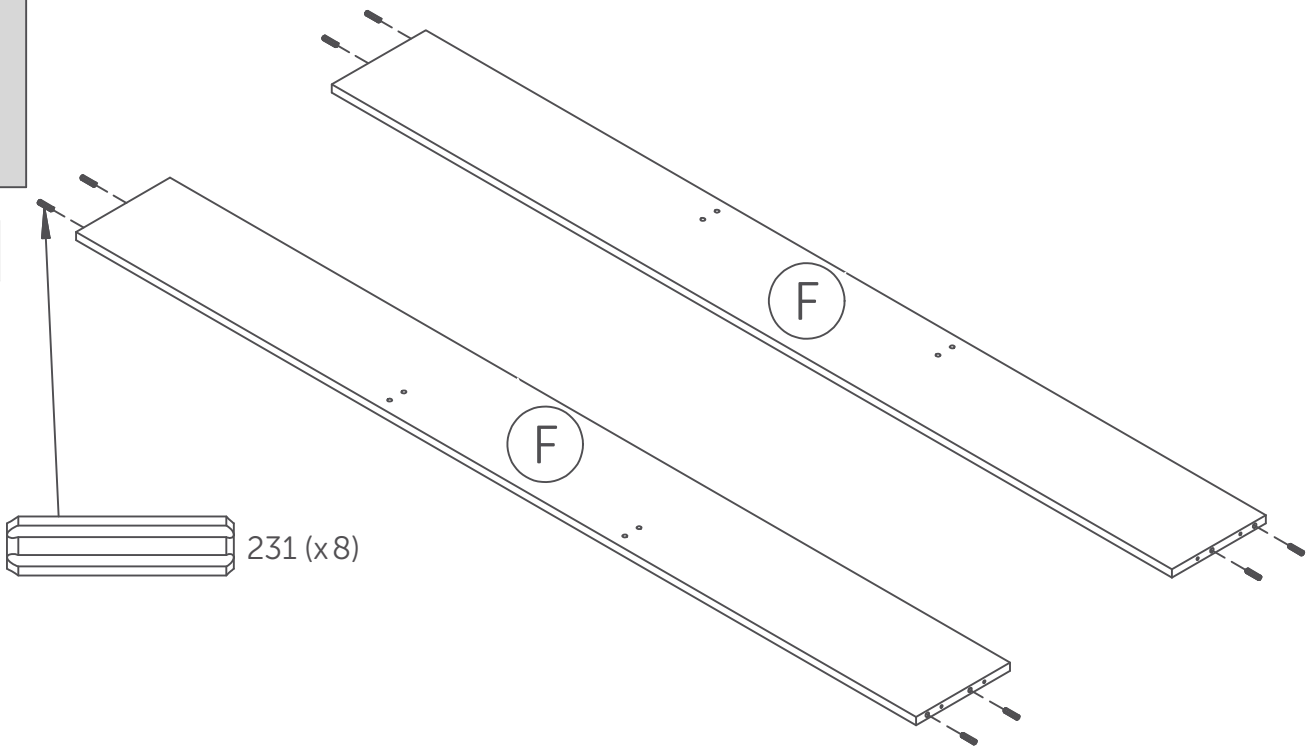

9.2

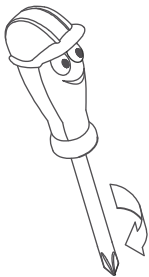

160 (x4)

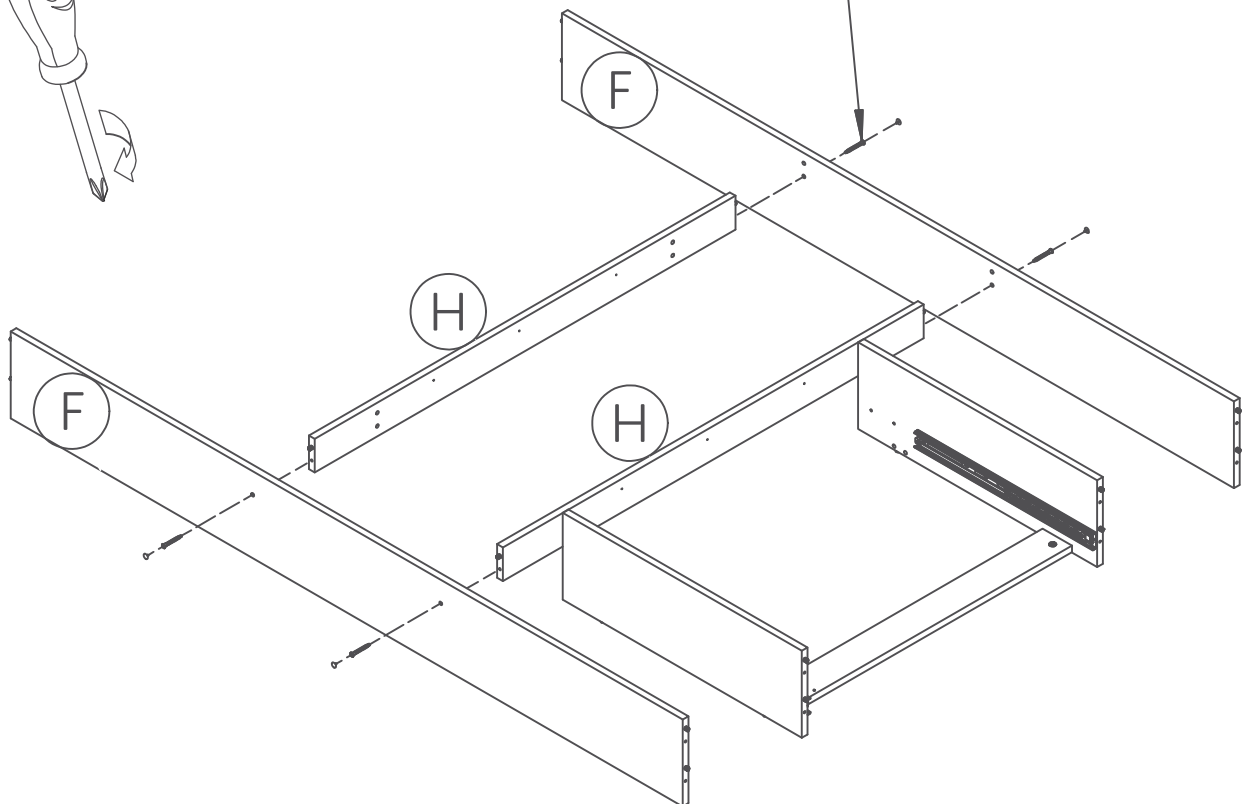

10

10.1

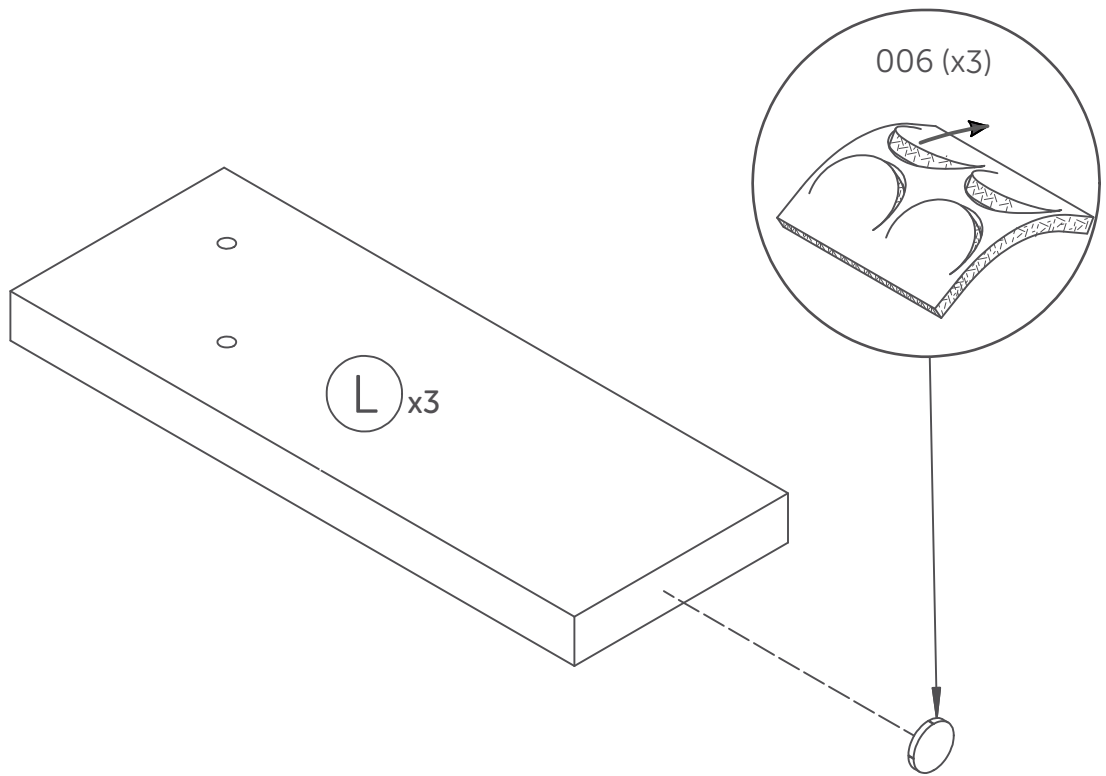

10.2

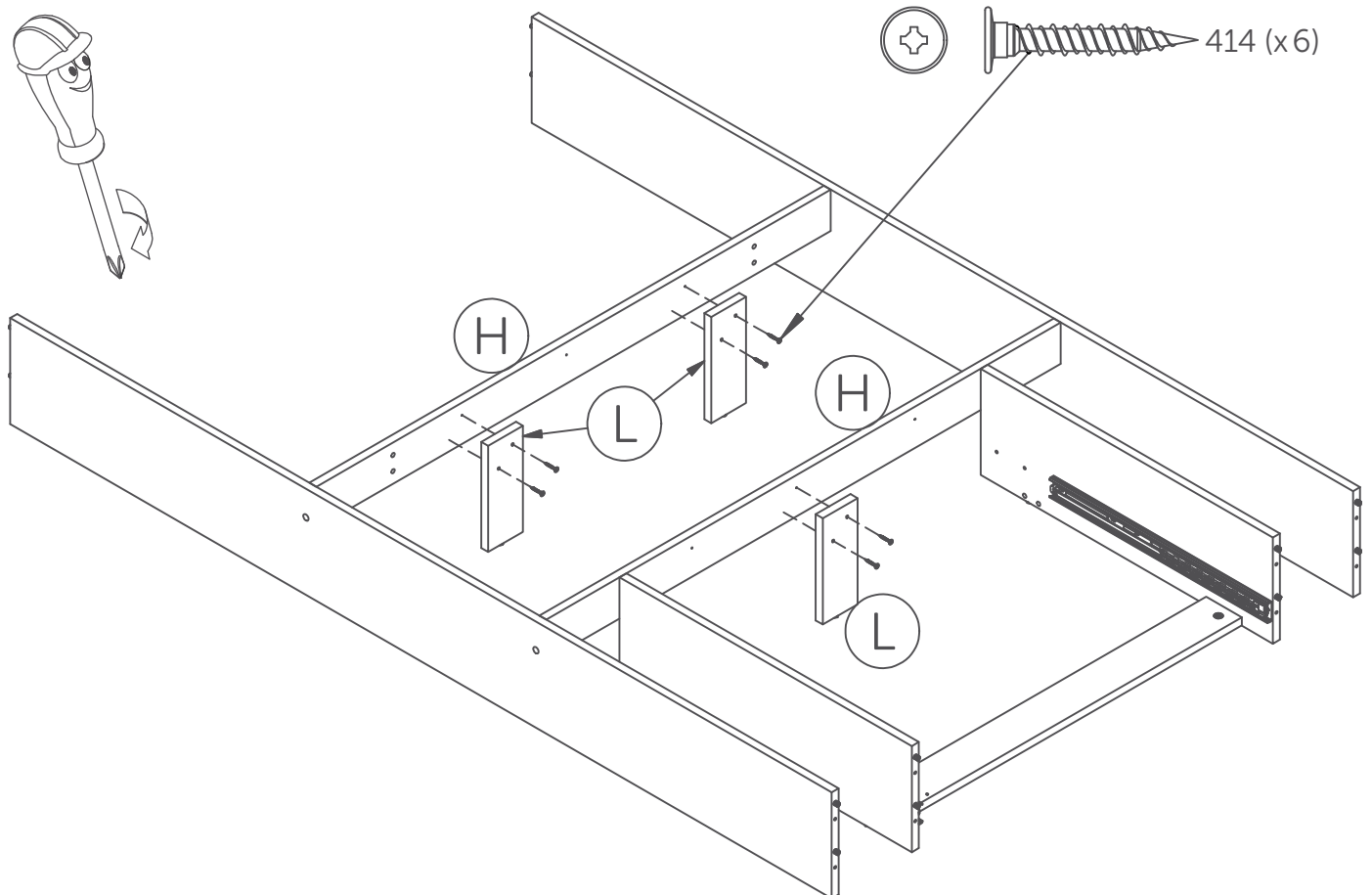
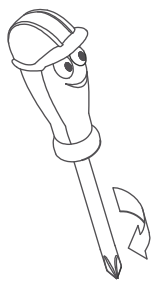

11

11.1

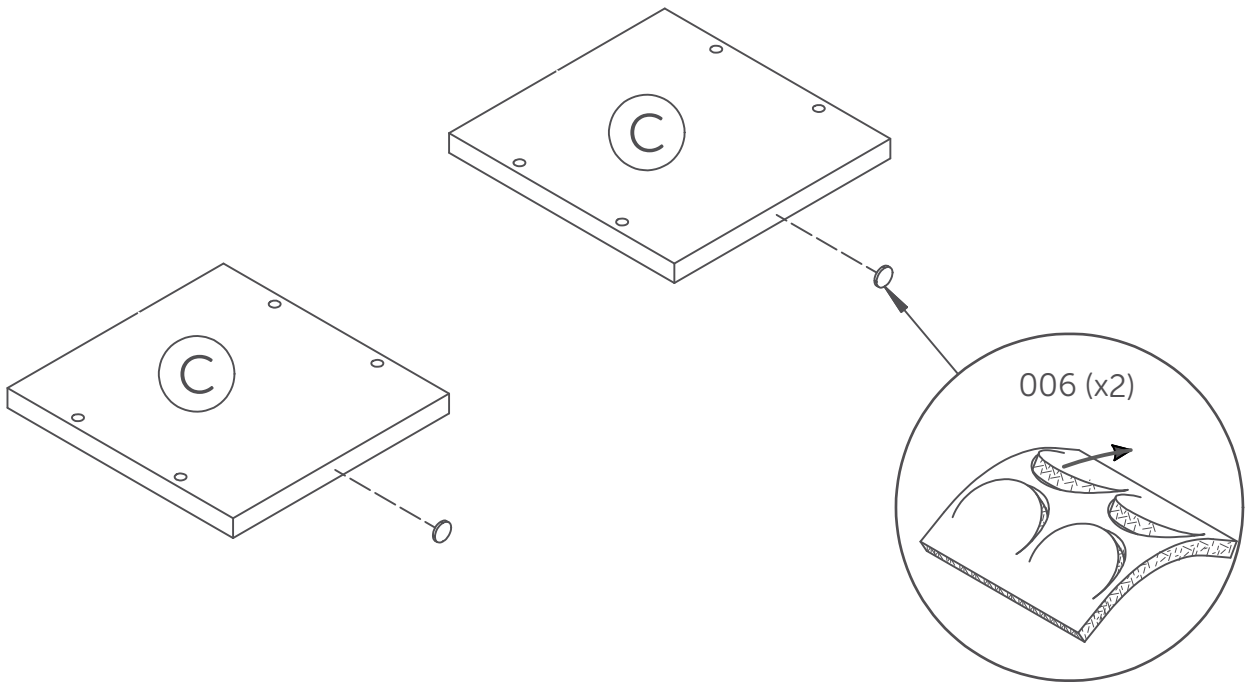

11.2

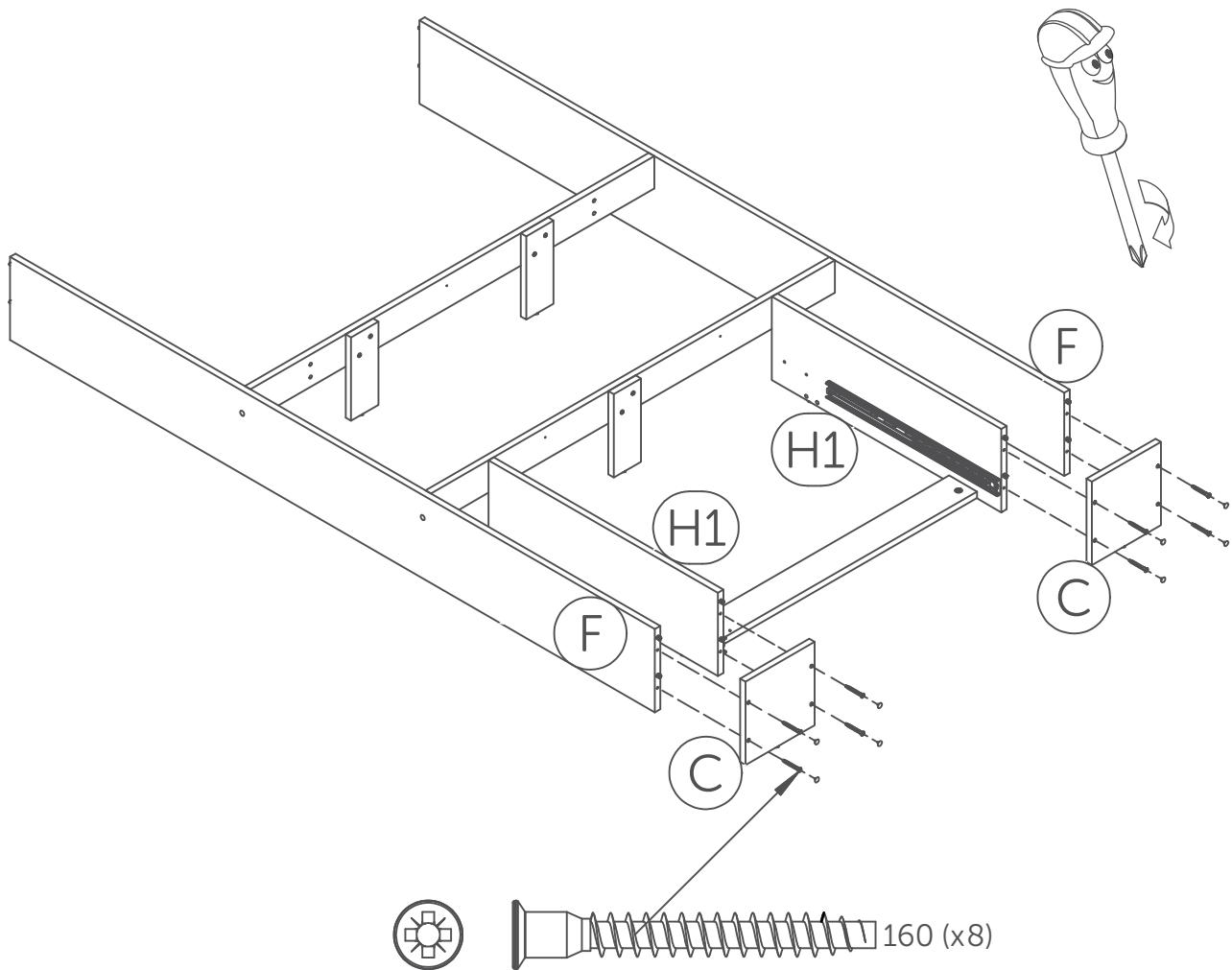

12

12.1

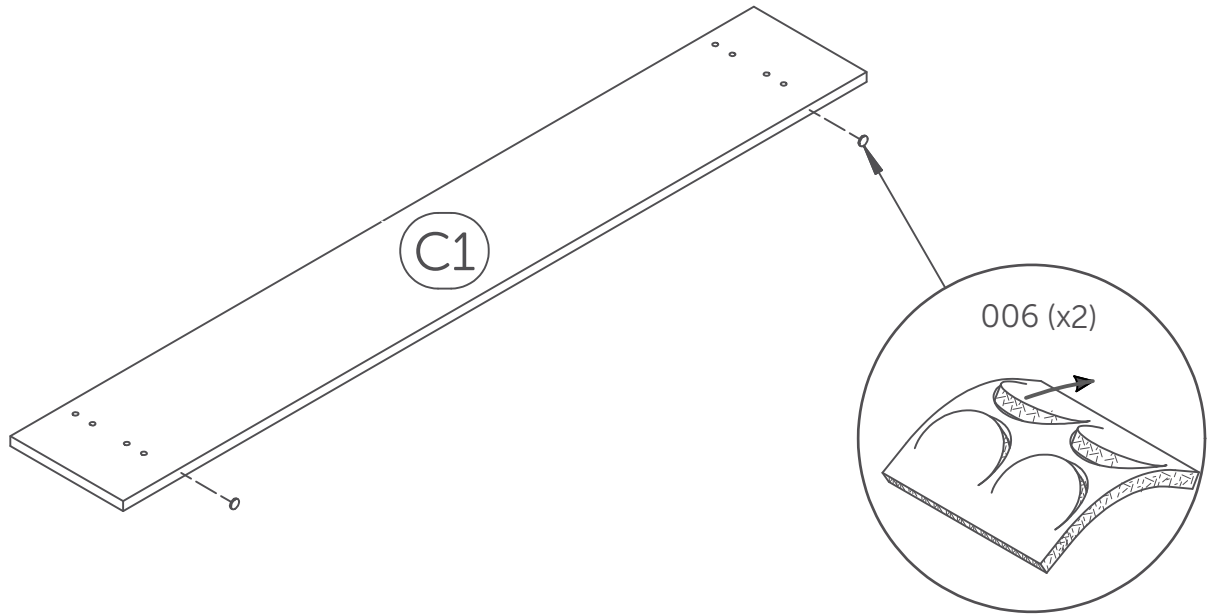

12.2

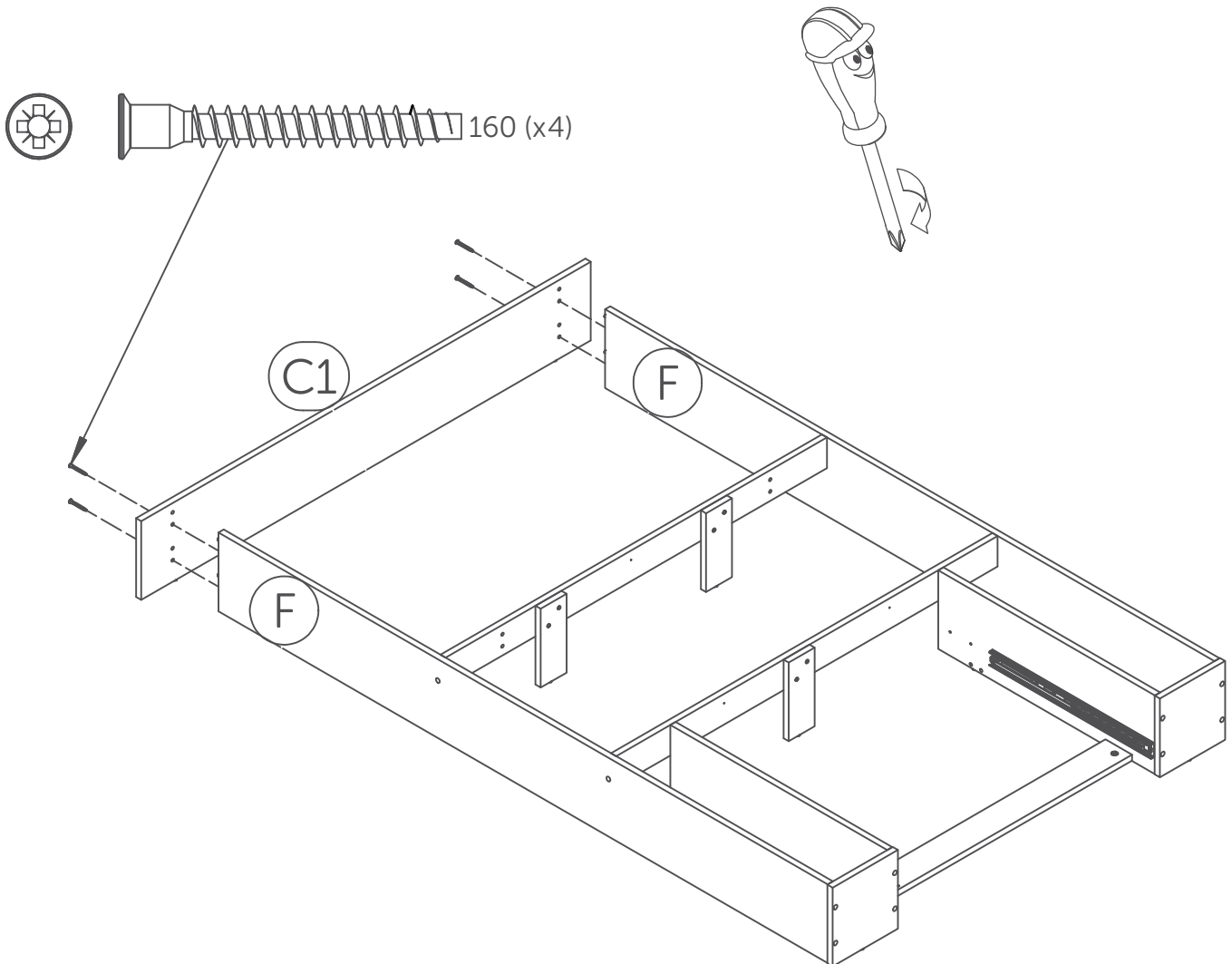

13



643 (x11)

Or
Ou
O



299 (x11)

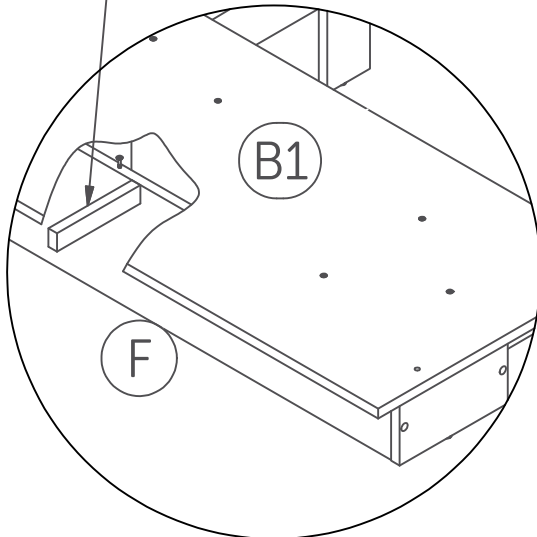
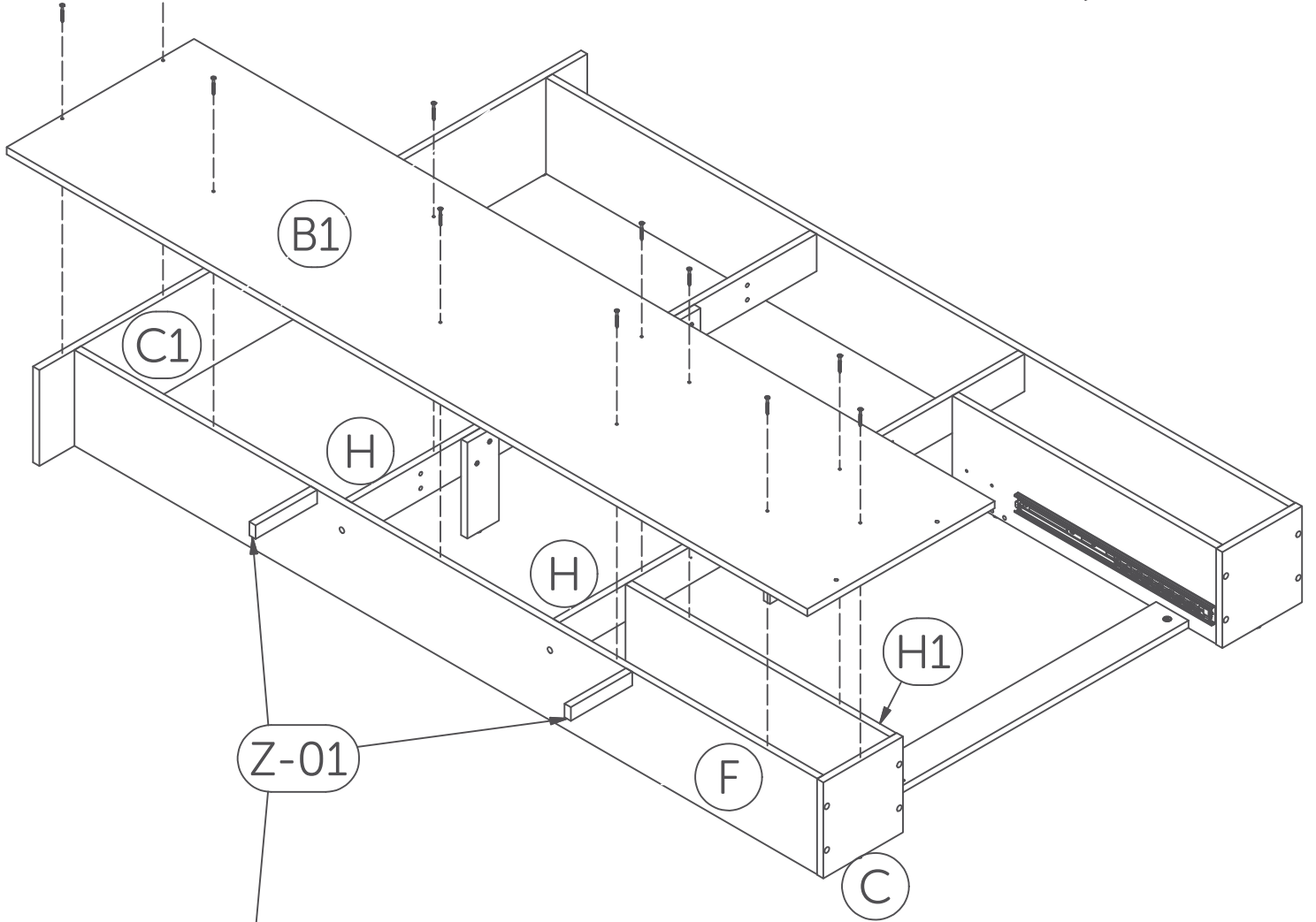
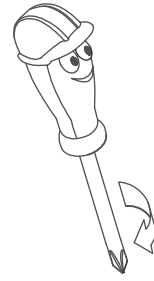

14

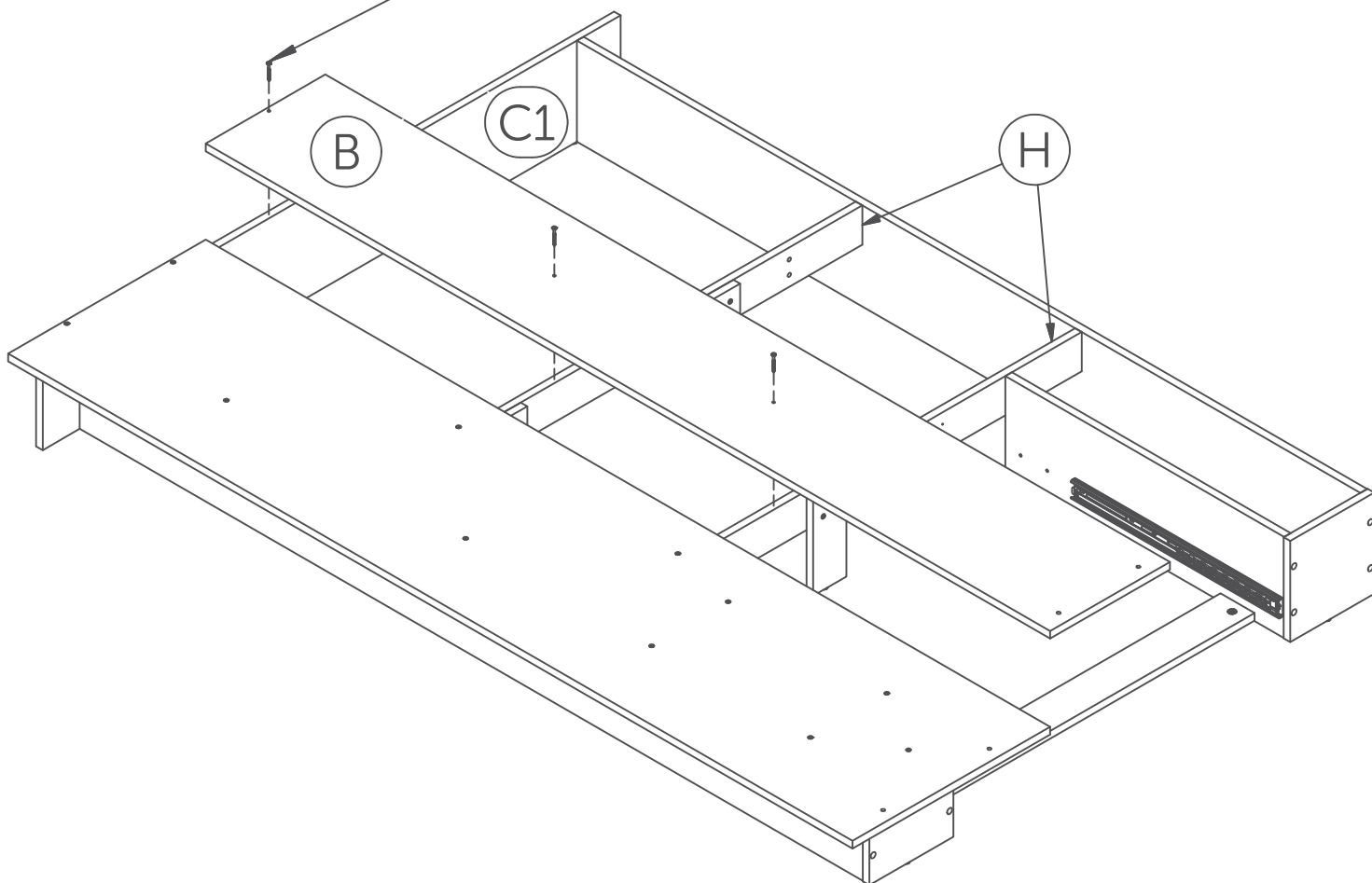
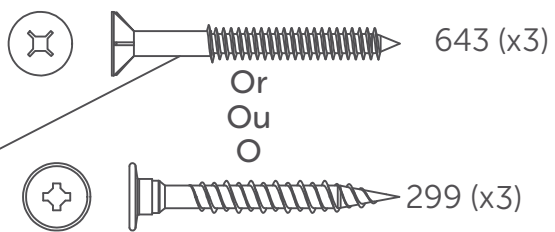
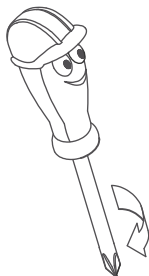

15

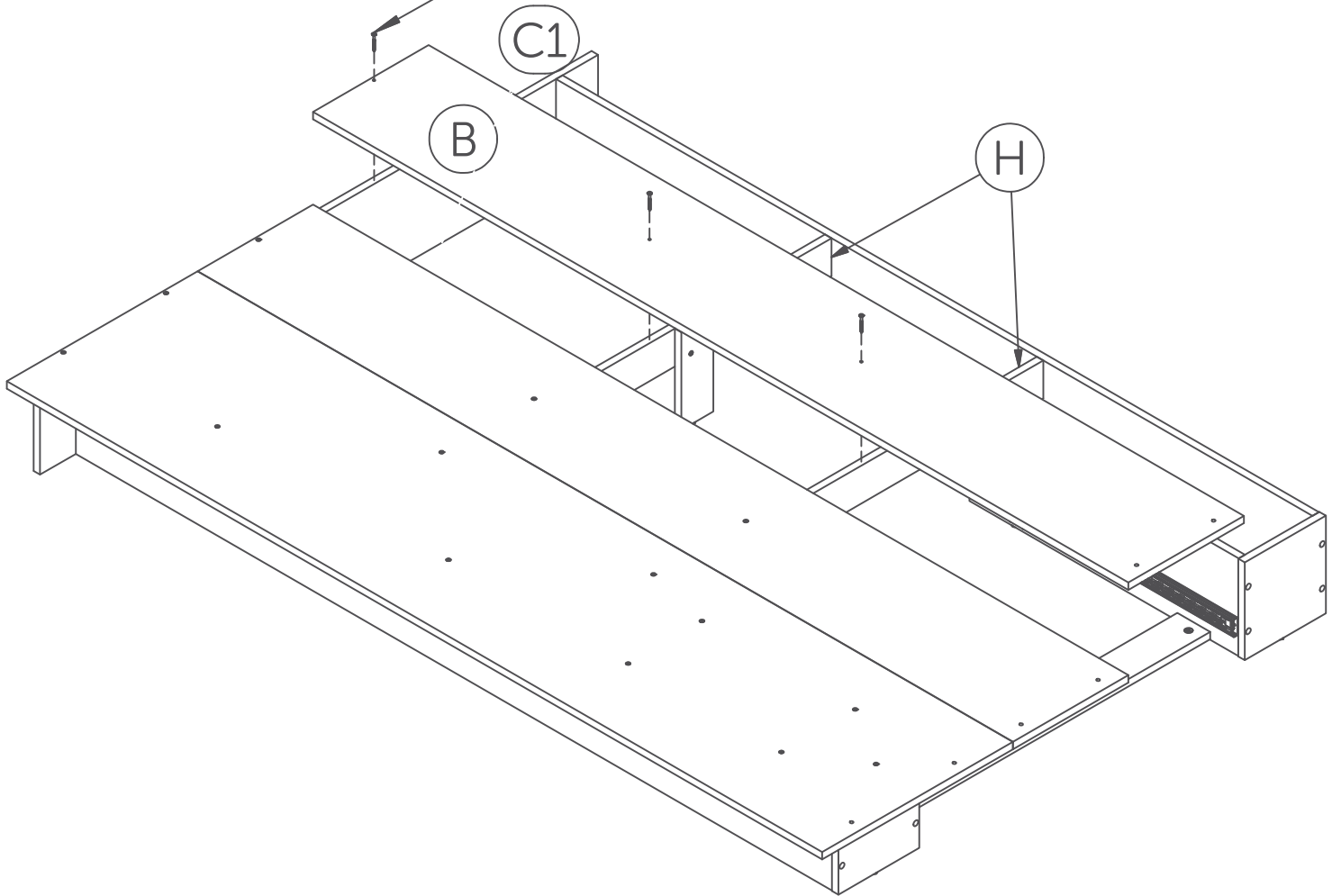
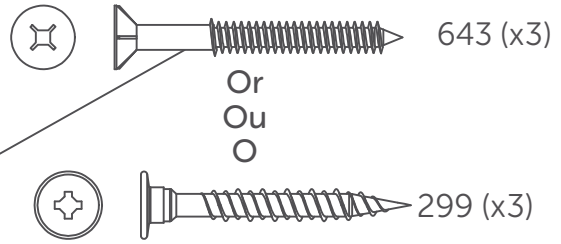
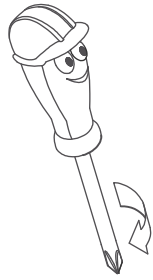

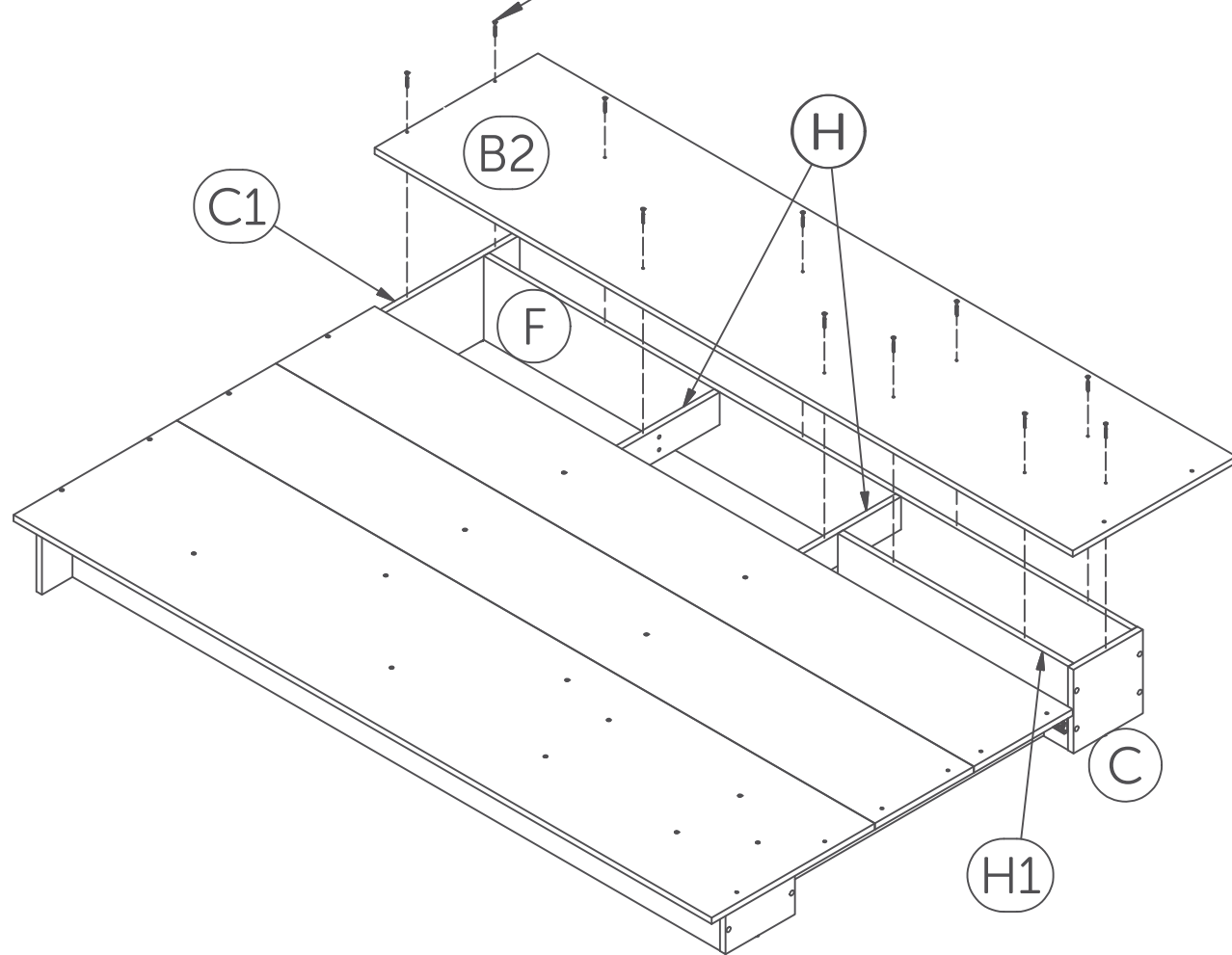
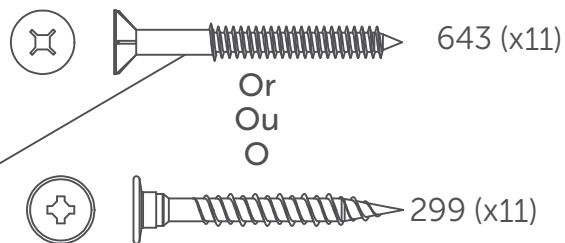
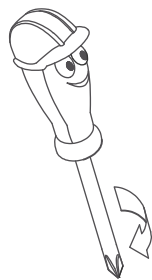

17

17.1

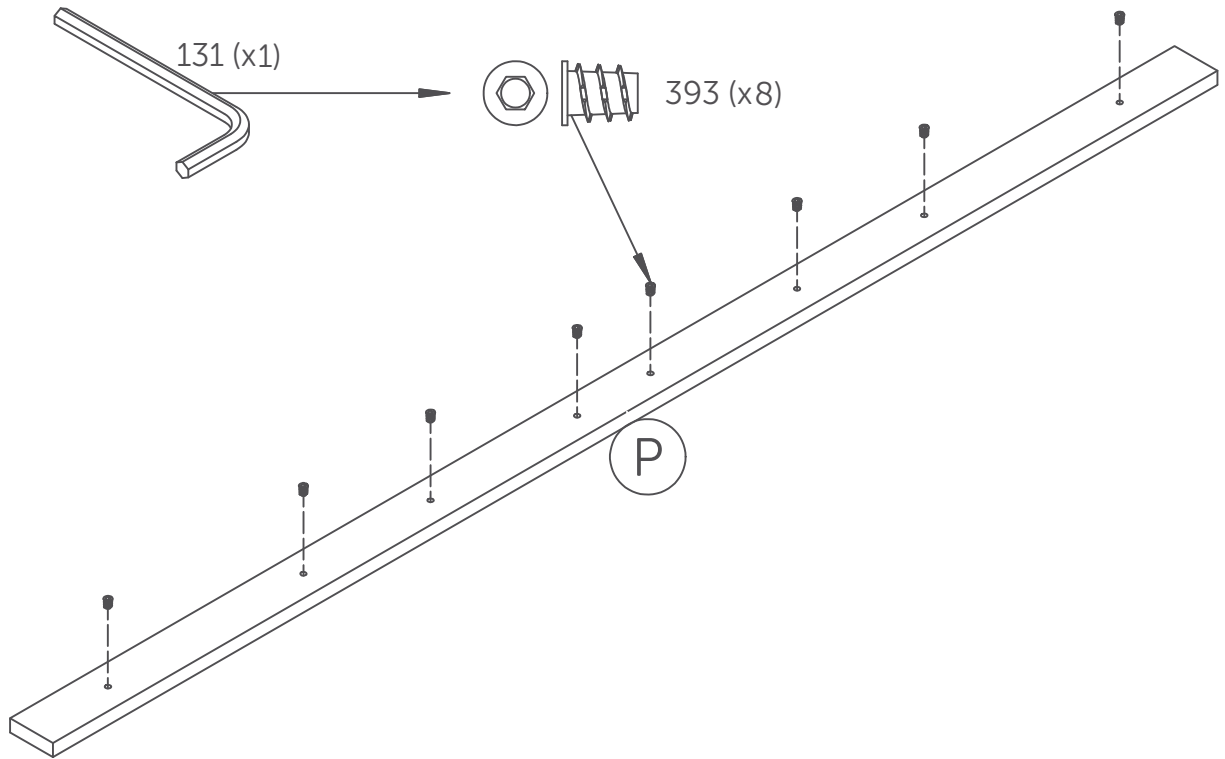

17.2

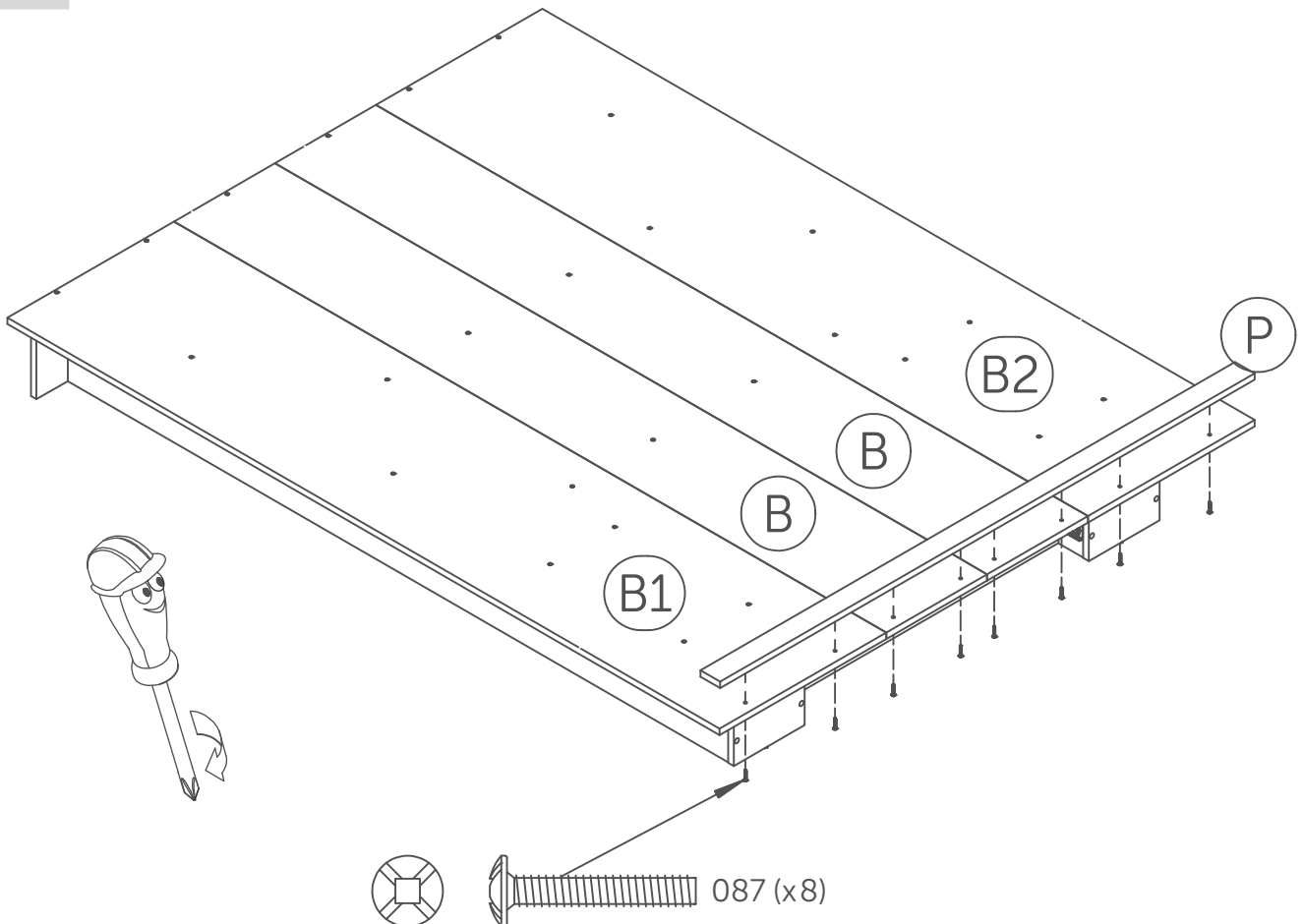

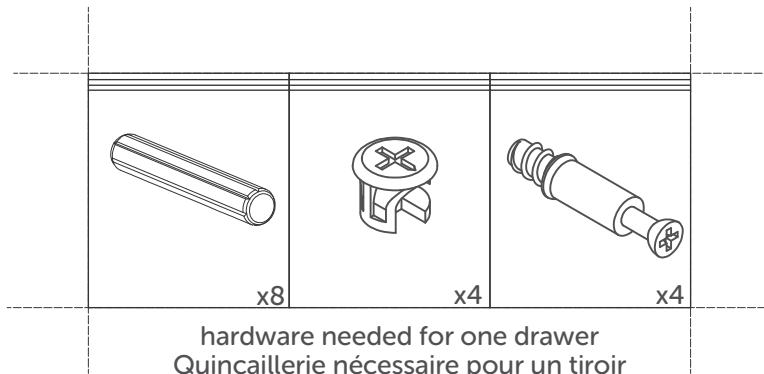
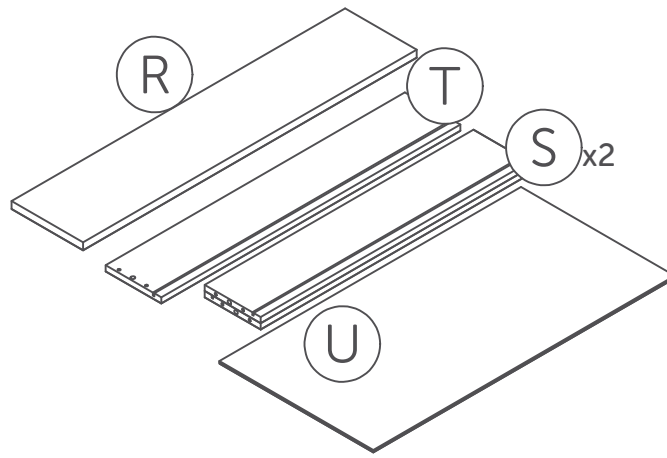

hardware needed for one drawer
 Quincaillerie nécessaire pour un tiroir
 Ferratería necesaria por cajón

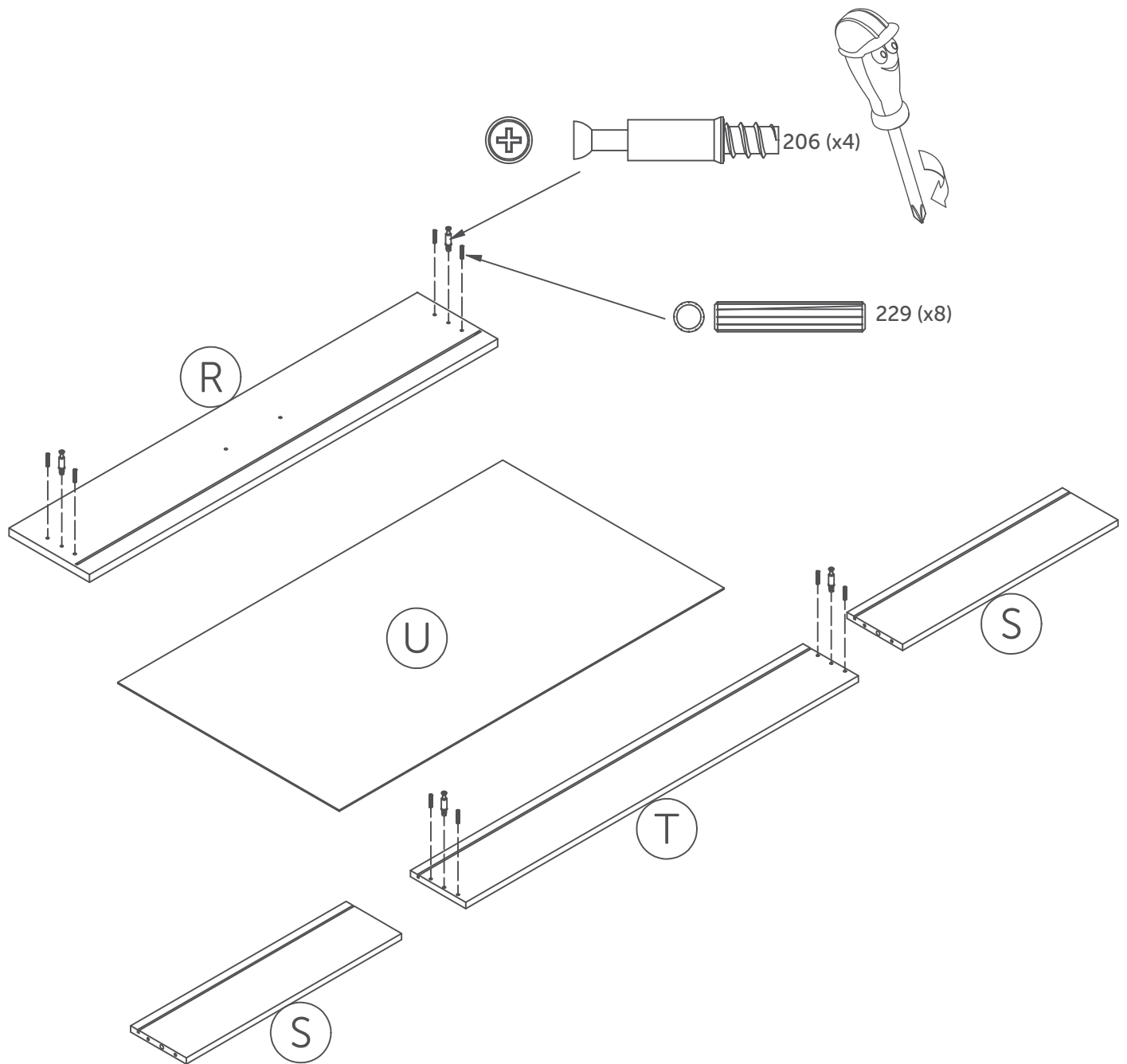

The image may differ depending on model
L'image peut différer selon le modèle
La imagen variar dependiendo del modelo

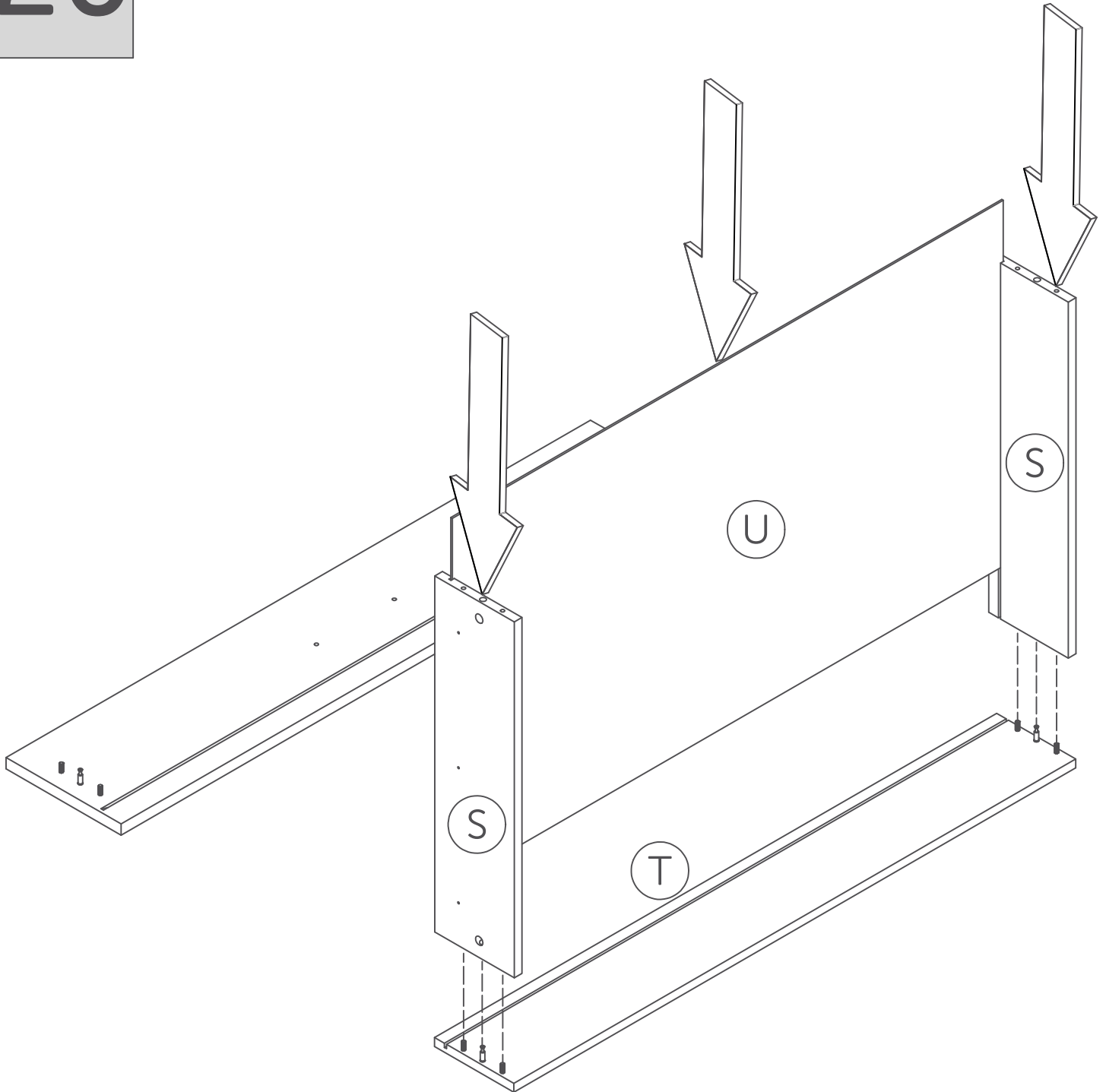

The image may differ depending on model
L'image peut différer selon le modèle
La imagen variar dependiendo del modelo

21

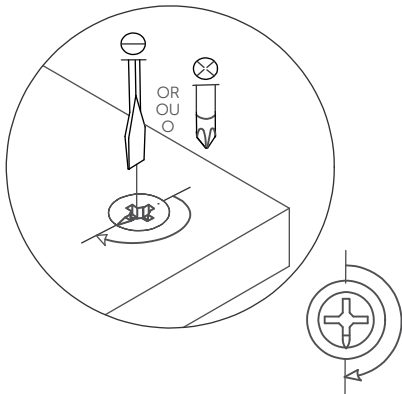
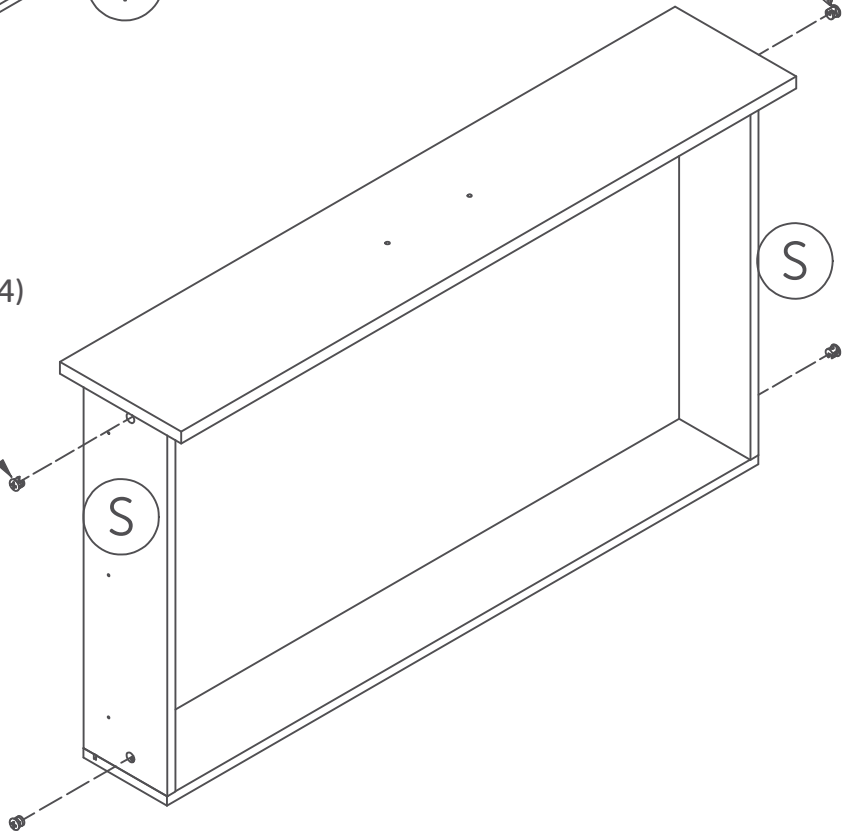
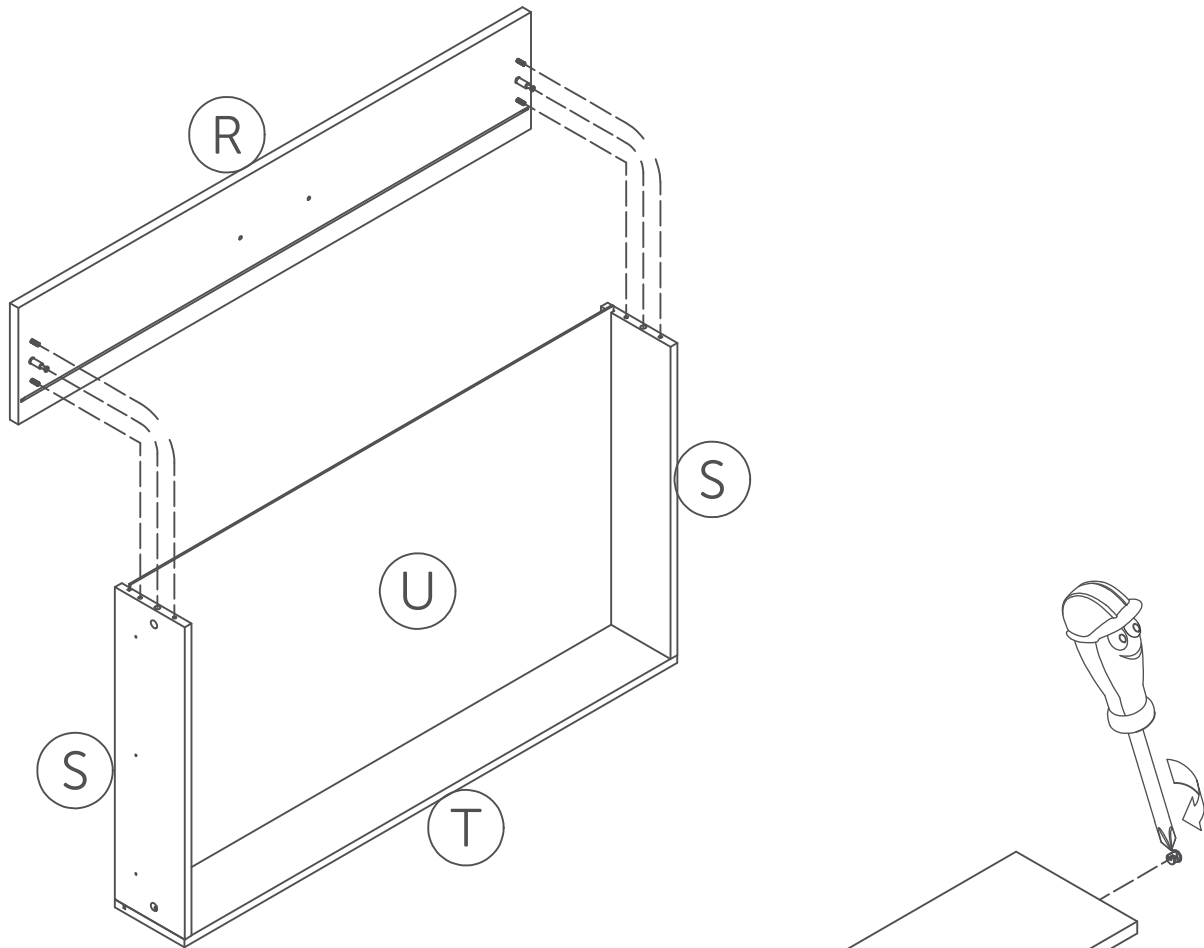

The image may differ depending on model
L'image peut différer selon le modèle
La imagen variar dependiendo del modelo

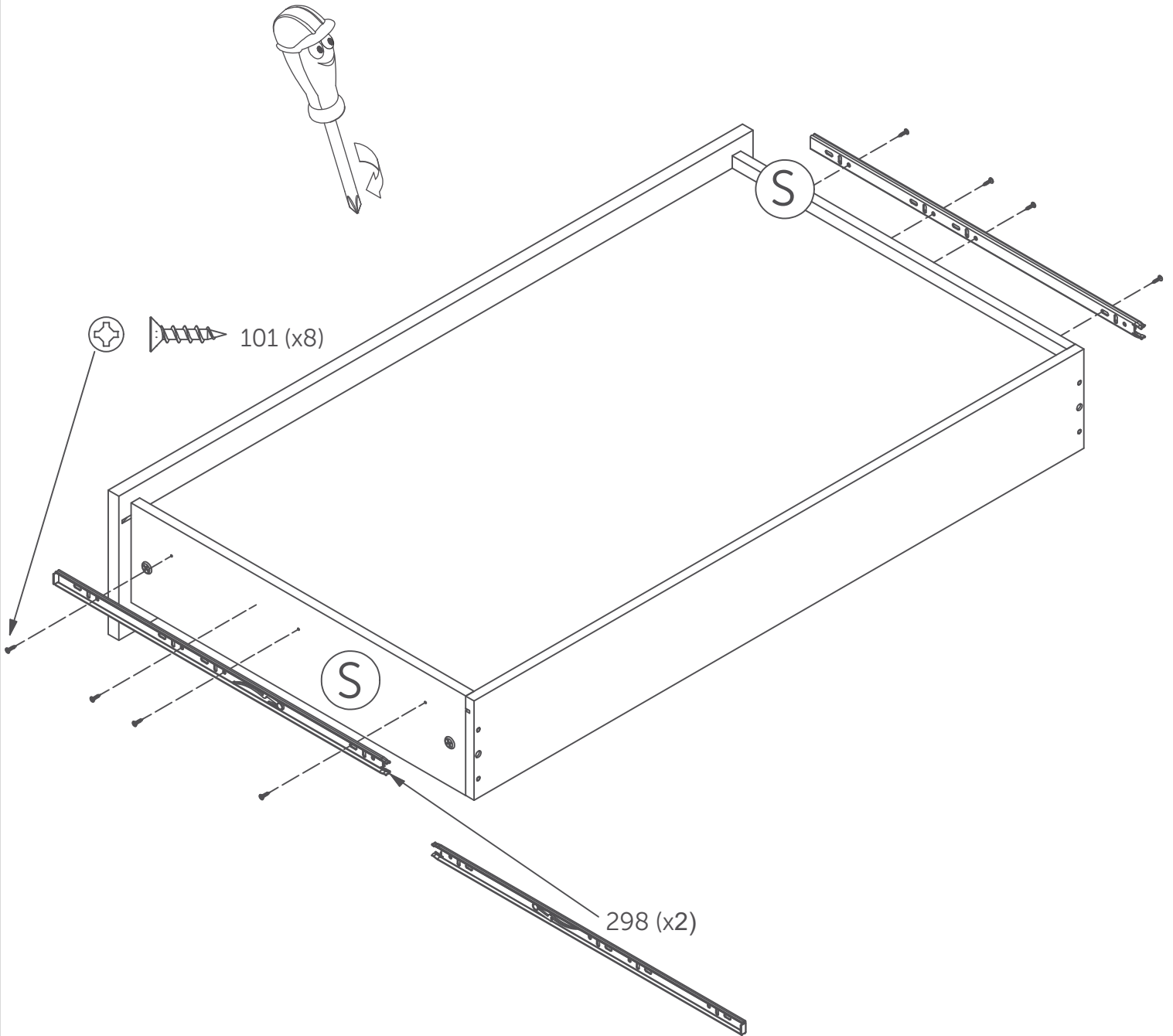

The image may differ depending on model
L'image peut différer selon le modèle
La imagen variar dependiendo del modelo

23

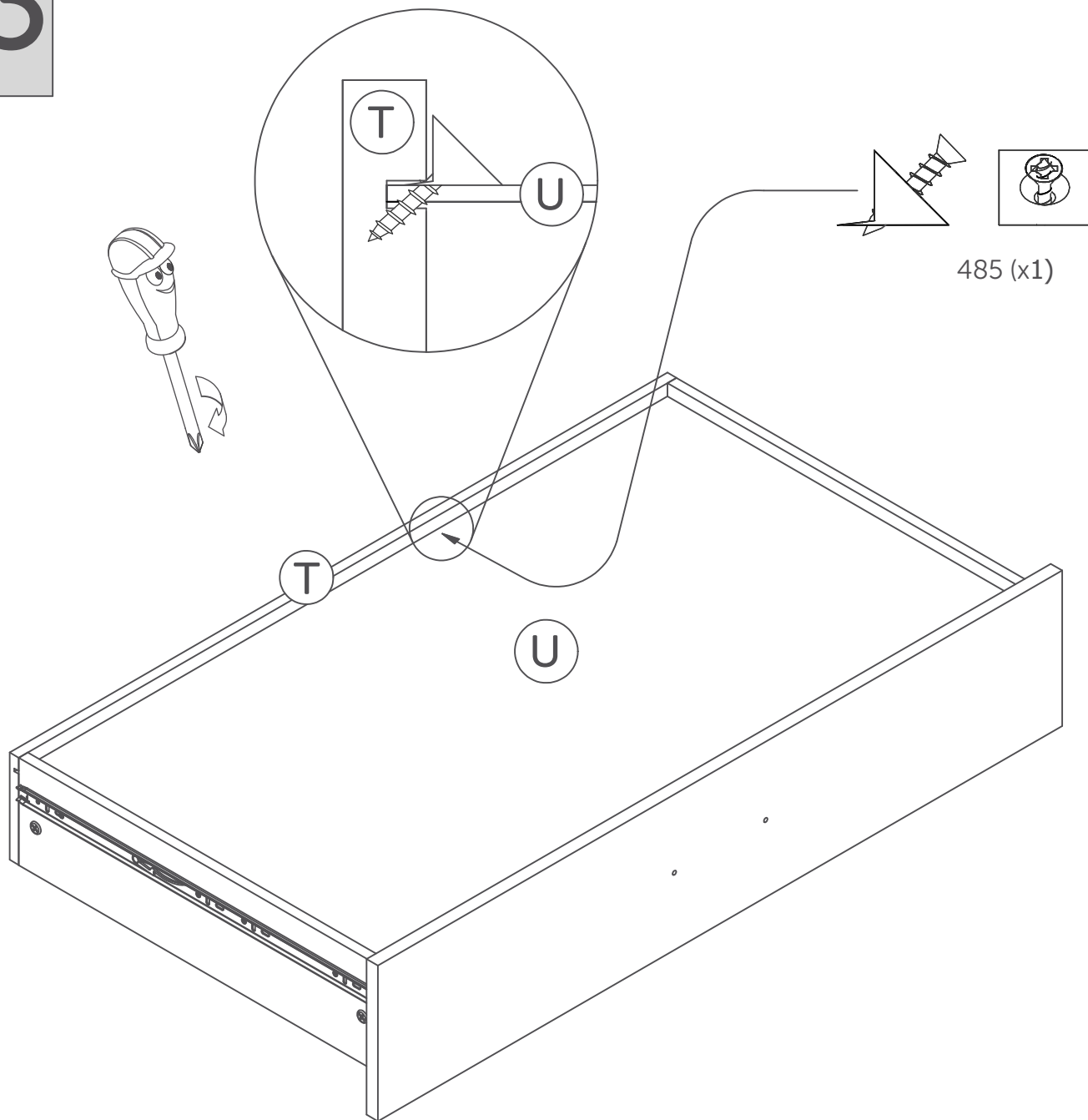

The image may differ depending on model
L'image peut différer selon le modèle
La imagen variar dependiendo del modelo

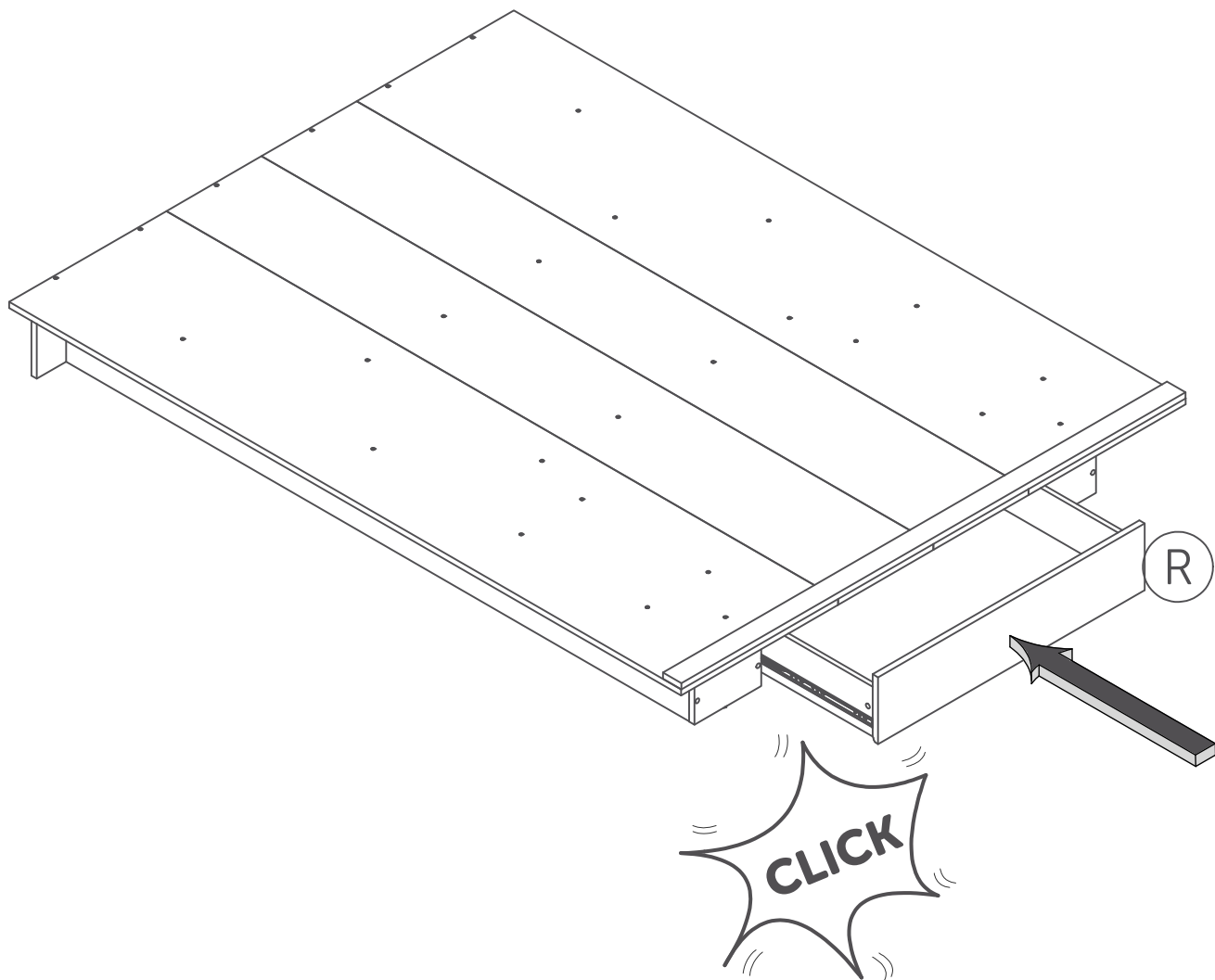

25

WEIGHT / POIDS / PESO

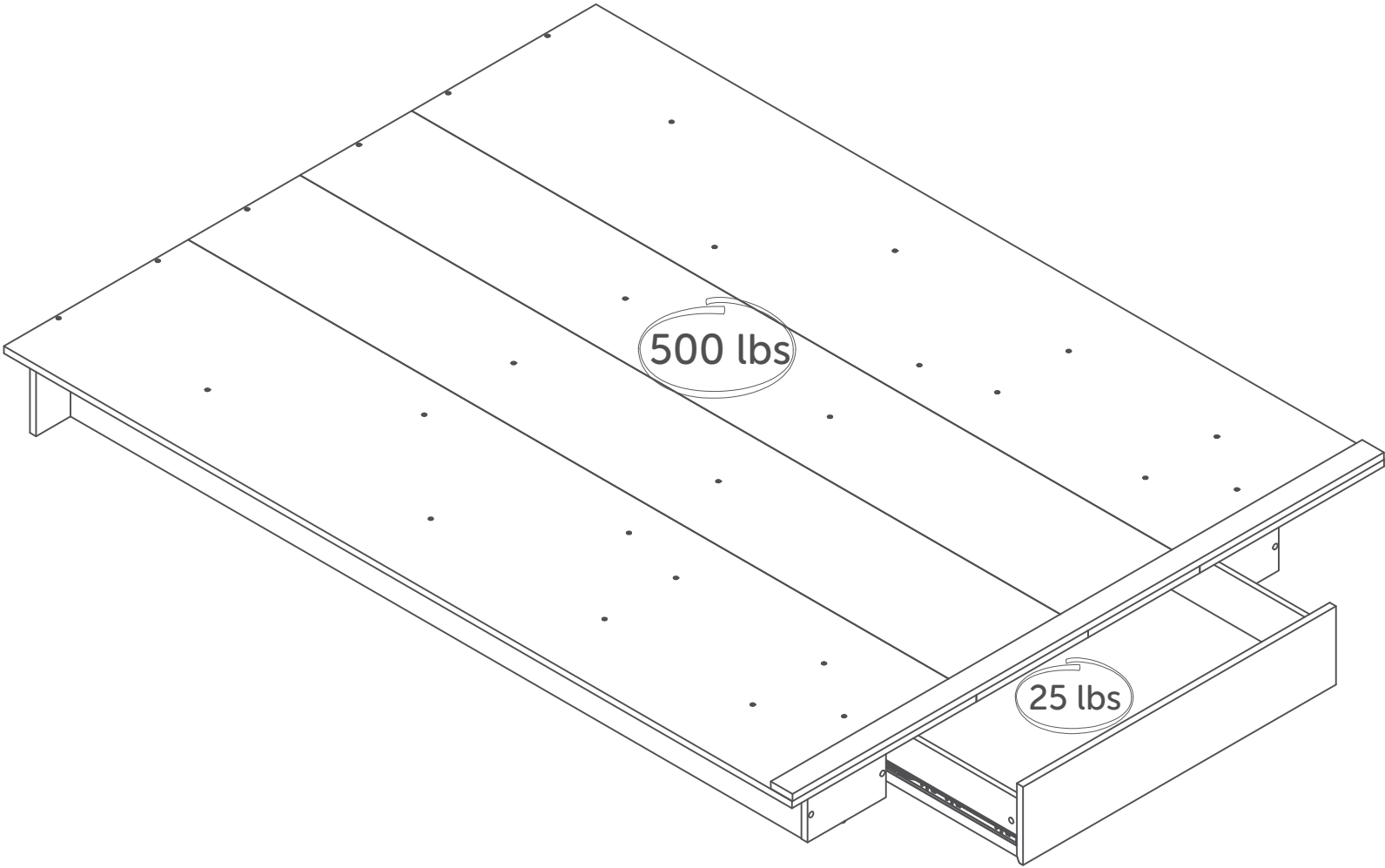

MAINTENANCE TIPS

CONSEILS D'ENTRETIEN / CONSEJOS DE MANTENIMIENTO



Never let liquids or damp cloths sit on this furniture.

Ne jamais laisser de liquide ou linge humide sur le meuble.

Nunca deje un líquido o un trapo húmedo sobre el mueble.



Never use chemical cleaning products. They can damage the finish. For cleaning, use only a slightly damp cloth and wipe dry.

Ne jamais utiliser de produits nettoyants à base de produits chimiques, cela va endommager le fini. Utiliser seulement un linge légèrement humide.

Nunca utilice limpiadores a base de químicos, estos dañaran le acabado. Use sólo un paño húmedo.

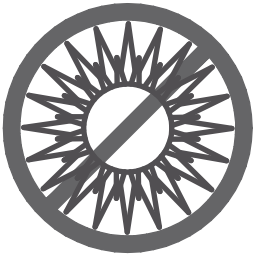

To avoid dulling of the finish, do not place furniture in direct sunlight.

Ne pas placer le meuble directement au soleil pour prévenir le ternissement.

No exponga el mueble directamente al sol para prevenir empañamiento.

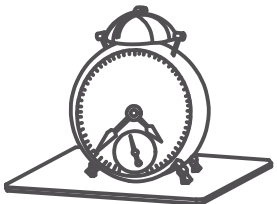

Do not put plastic or rubber rings under appliances. Use cloth or felt protectors.

Évitez de déposer des appareils avec des rondelles de plastique ou de caoutchouc. Utilisez un protecteur en tissu ou en feutre.

Evite apoyar aparatos con redondeles de plástico o de goma. Utilizar un protector de tela o de fieltro.



To clean, use a soft or slightly damp cloth, then wipe with a clean, dry cloth.

Pour nettoyer, utilisez un linge doux ou légèrement humecté. Essuyez par la suite avec un linge propre et sec.

Para limpiar, utilice un trapo suave o ligeramente humedecido. Seque luego con un trapo limpio y seco.