

SWIVEL DINING ARM CHAIR
FAUTEUIL PIVOTANT POUR SALLE À MANGER
SILLÓN GIRATORIO PARA COMEDOR

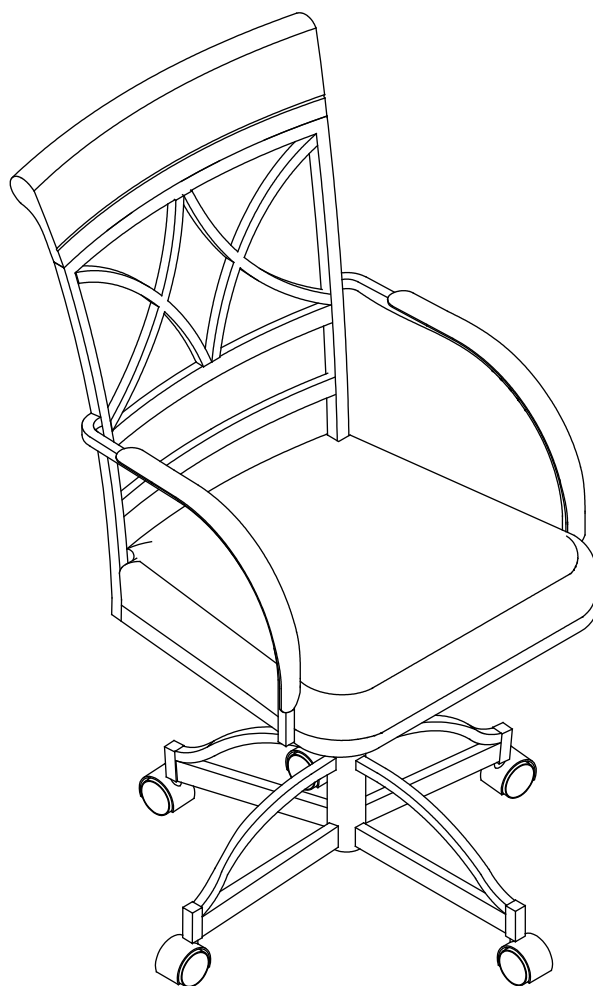

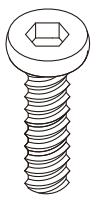

A x 4
($\Phi 1/4'' \times 3/4''$)

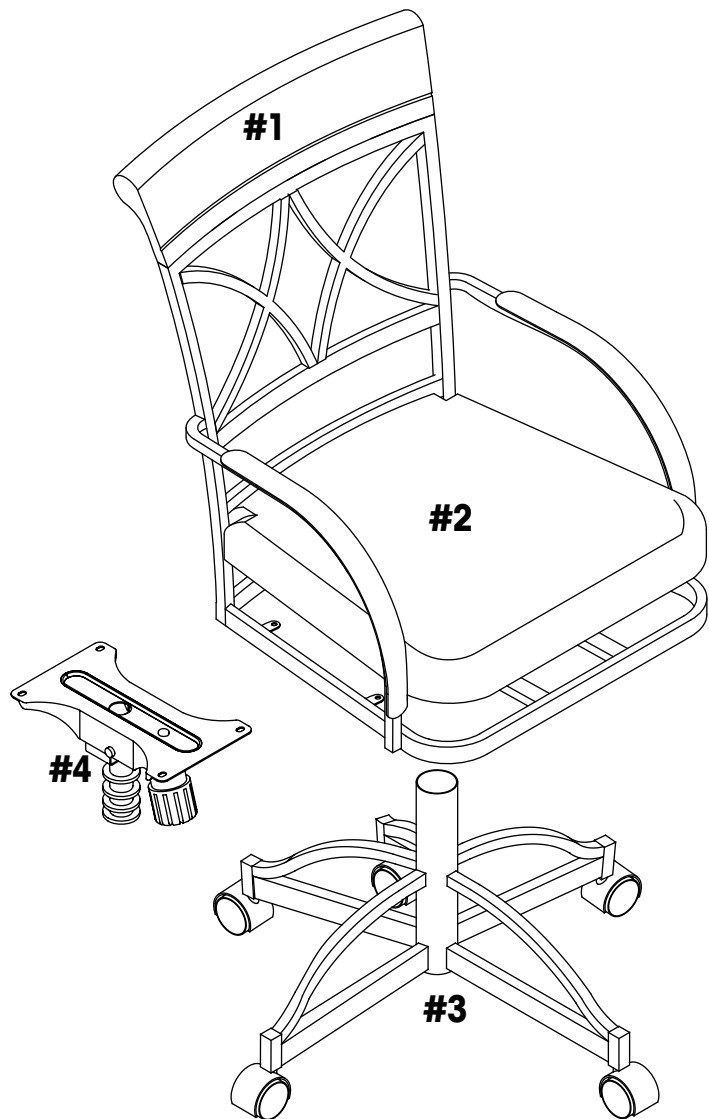
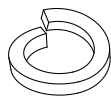

B x 4
($\Phi 1/4''$)

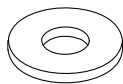

C x 4
($\Phi 1/4''$)

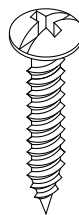

D x 4
($\Phi 1/8'' \times 3/4''$)

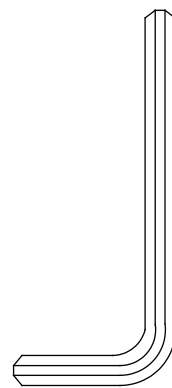





supplied
fourni
suministrado

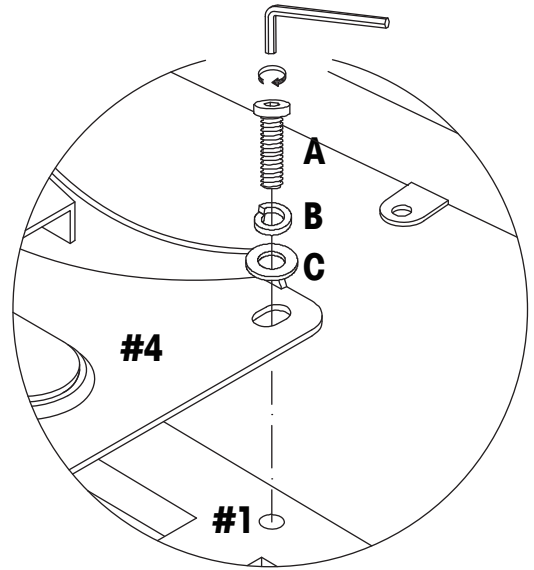
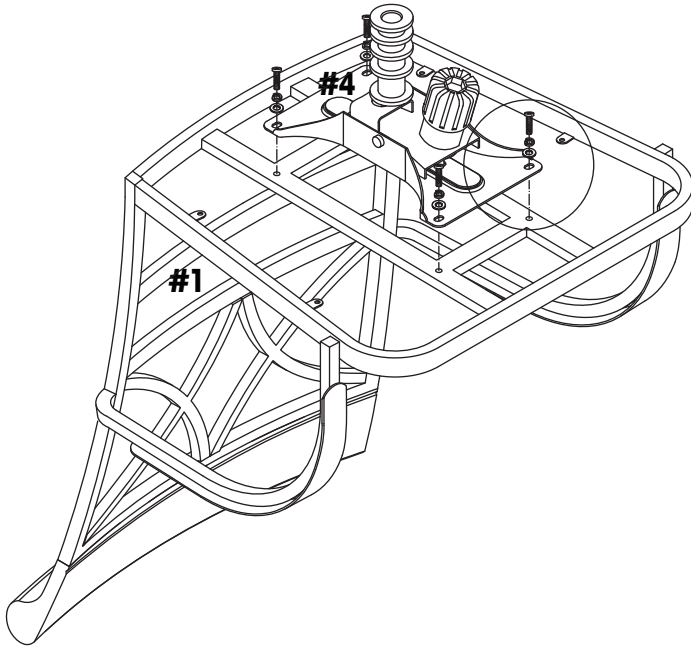

not supplied
non fourni
no suministrado

1.



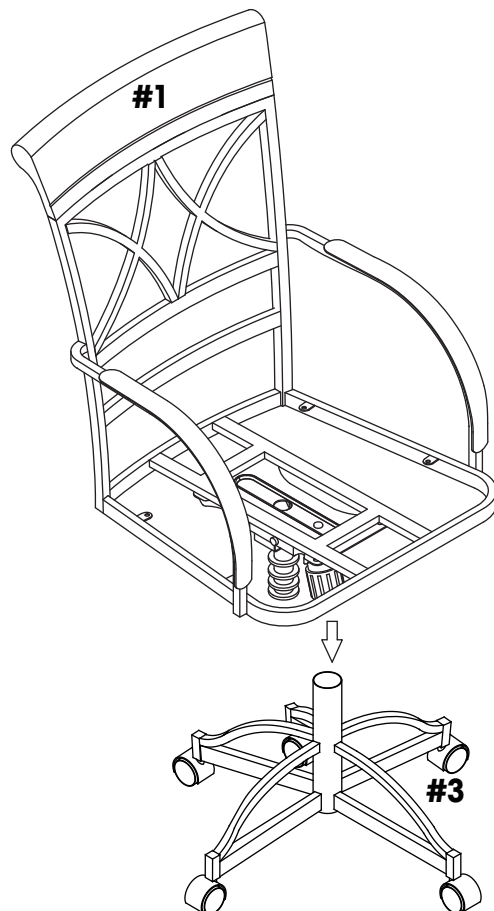

A		04
B		04
C		04

2.

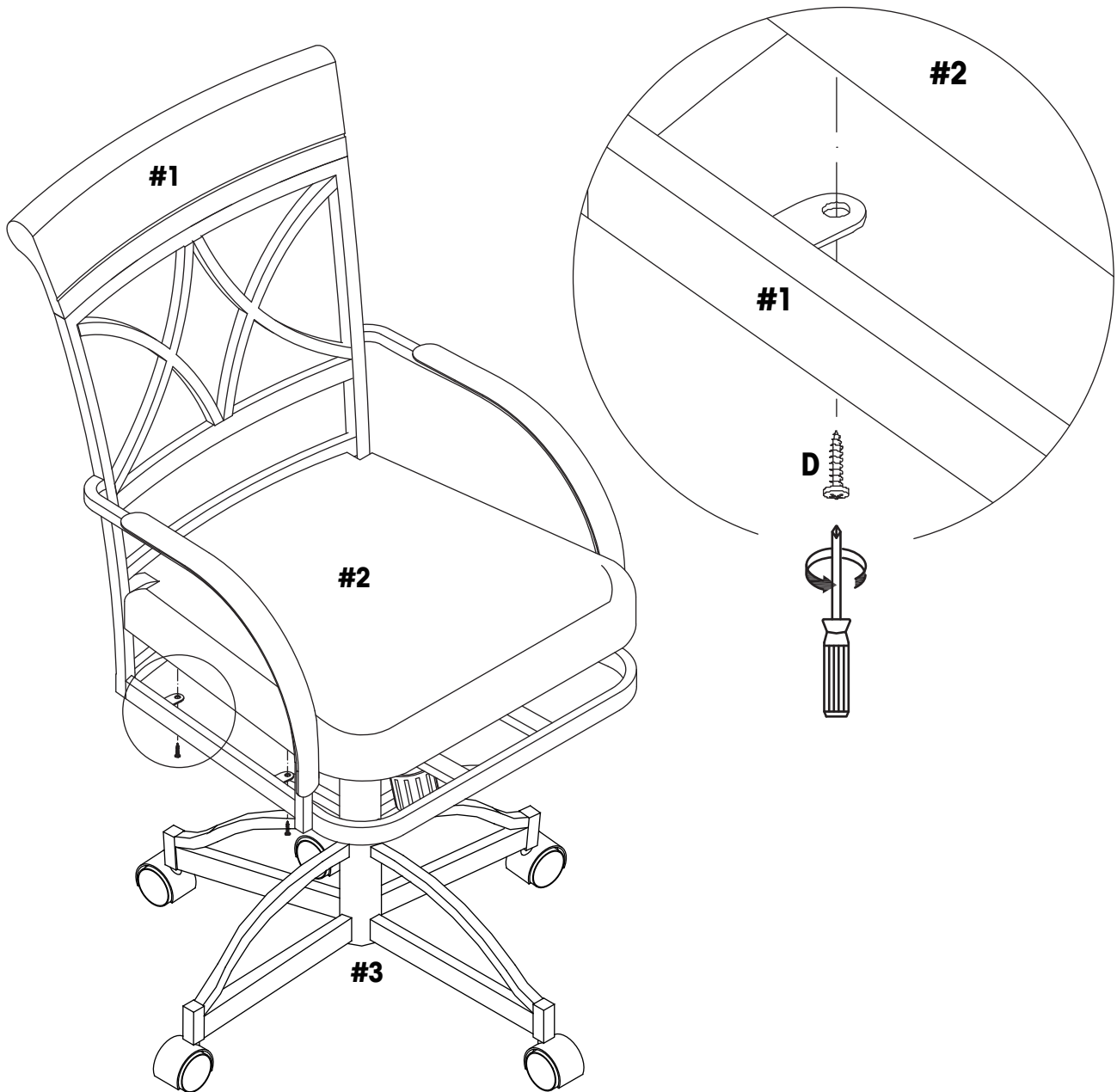

3.



D		04
---	---	----

