

# DIMENSIONS

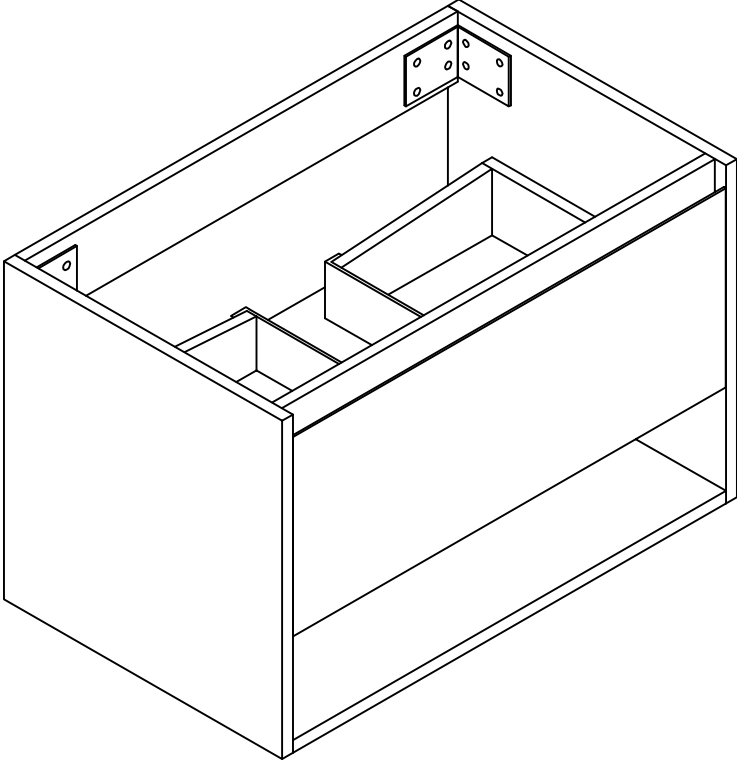

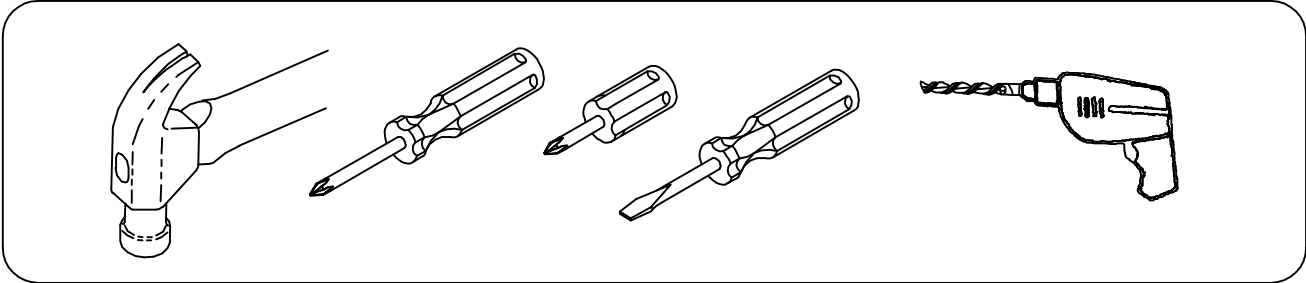





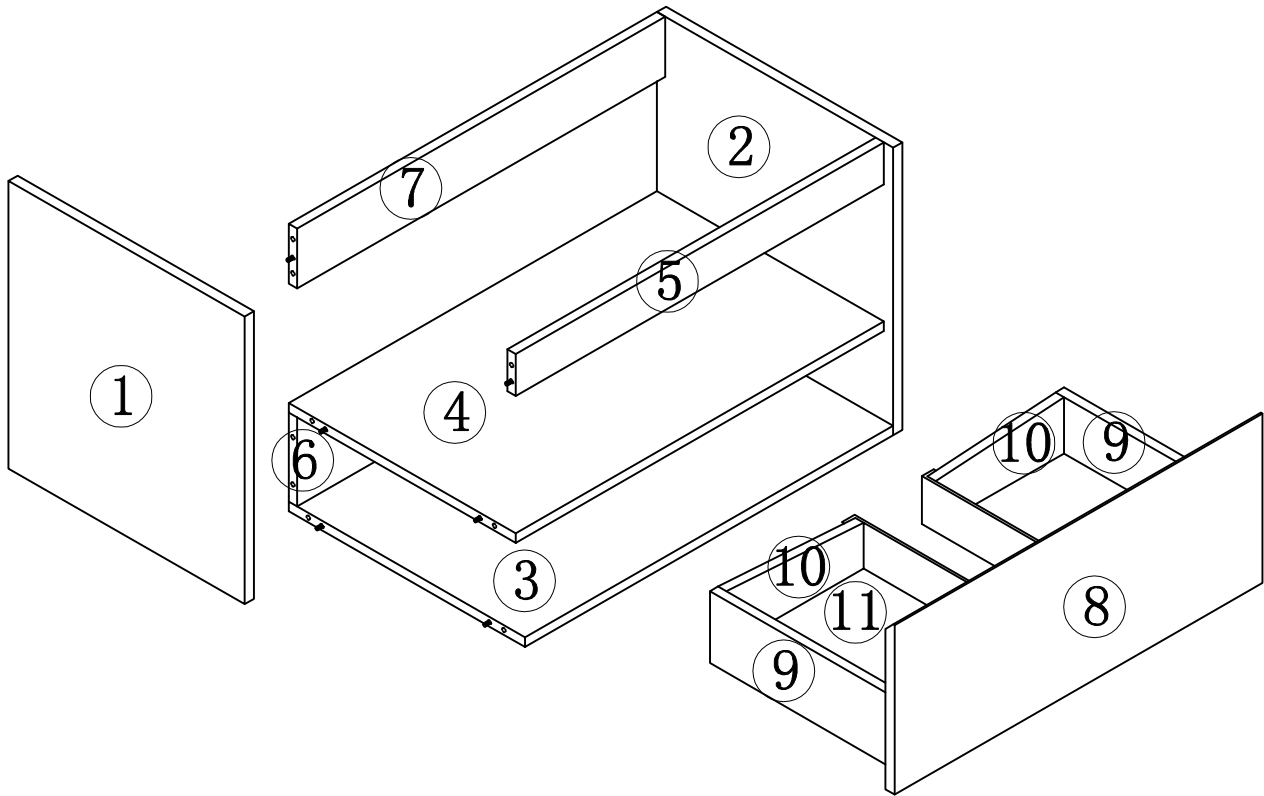





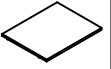

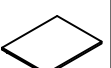



## YOU MAY NEED (NOT SUPPLY)



# ASSEMBLY DIAGRAM





PARTS LIST					
PARTS LIST					
NO	DESCRIPTION	QTY	NO	DESCRIPTION	QTY
①	Left side panel 	1	⑧	drawer panel 	1
②	Right side panel 	1	⑨	drawer side panel 	2
③	Bottom panel 	1	⑩	drawer back panel 	2
④	laminate 	1	⑪	Drawers bottom panel 	1
⑤	front pull-up 	1			
⑥	rear drop down 	1			
⑦	rear pull-up bar 	1			

PARTS LIST					
HARDWARE LIST					
NO	DESCRIPTION	QTY	NO	DESCRIPTION	QTY
A	Three-in-one eccentric wheel 	32	E	Drawer slides 	2
B	Three-in-one connecting rod 	32	F	4*16mm screw 	38
C	Three-in-one sticker 	32	G	Drawer U-shaped plastic 	1
D	8*40mm wood dowel pins 	16	H	White angle bracket 	2
<b>CAUTION:</b> Please confirm the parts list before installation					

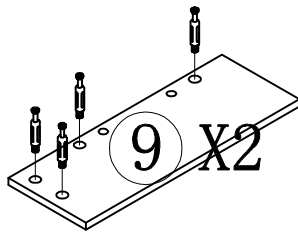
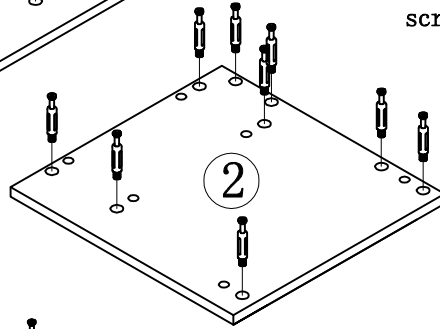
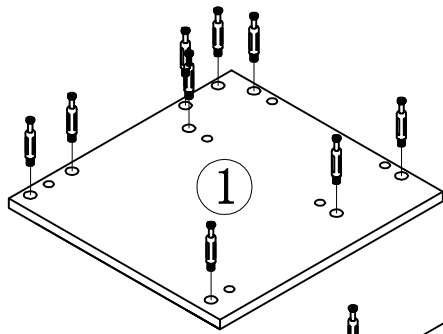
# STEP 1



HARDWARE LIST	
Three-in-one connecting rod B  32PCS	

1. Put the three-in-one connecting rod in the 10mm hole of the following panels and tighten them with a cross screwdriver or an electric tool.

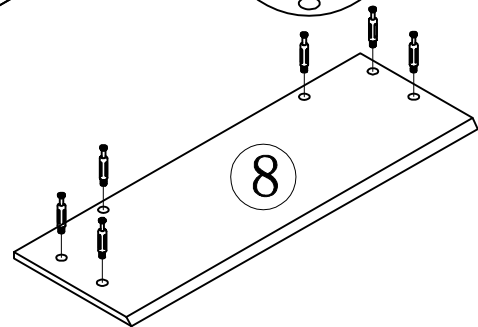
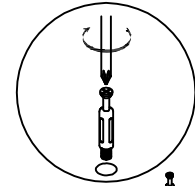

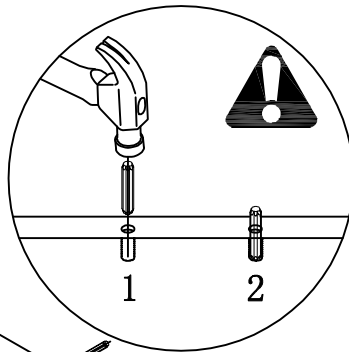

# STEP 2



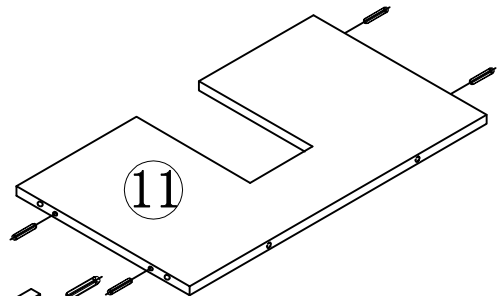
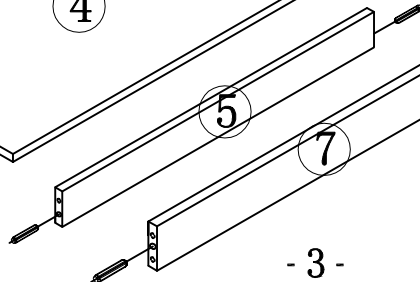
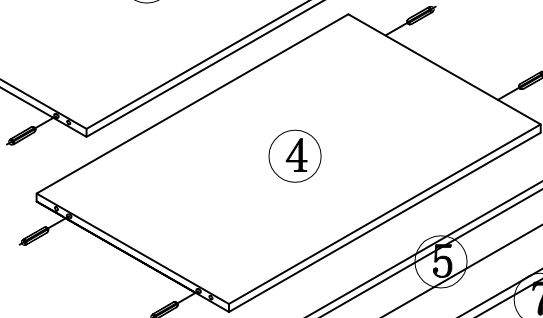
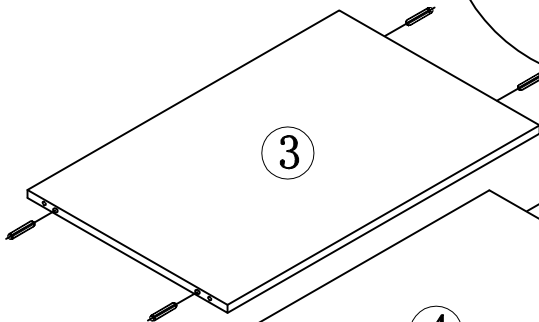

1. Strike the 8\*40mm wood dowel pin into the 8mm hole of the above panels with an iron hammer. Please note that the hole of the three-in-one connecting rod should also be 8mm. The hole of the three-in-one connecting rod connects to the hole of 15mm three-in-one eccentric wheel.

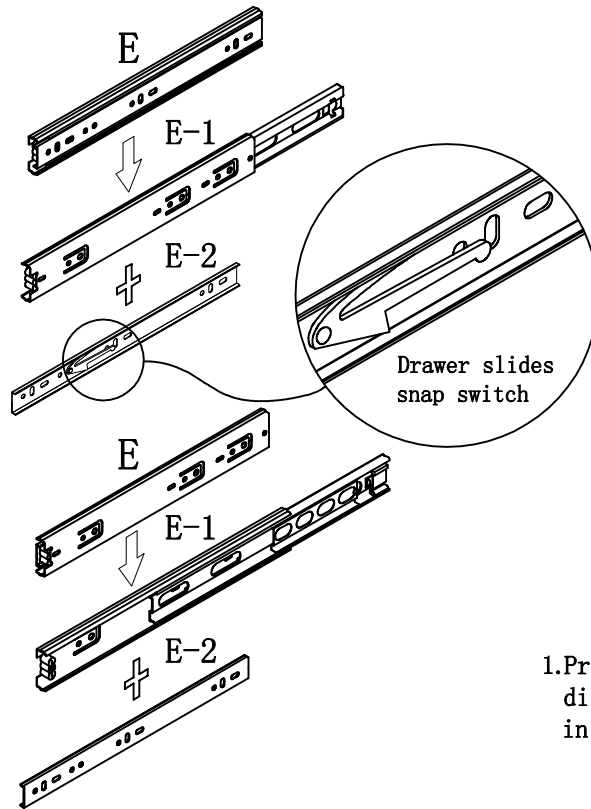

HARDWARE LIST	
8*40mm wood dowel pins D  16PCS	

# STEP 3







HARDWARE LIST	
Drawer slides	
E  2PCS	

1. Press the slide snap switch, disassemble slide blocks and put them in a place properly for further use.

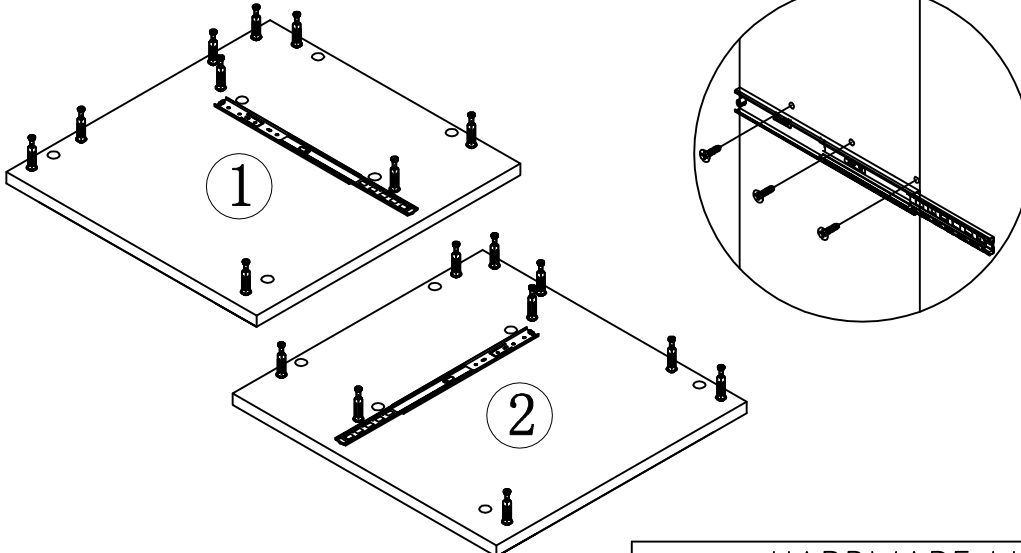
# STEP 4

1. Fix the drawer slide to the side panel with 4\*16mm screws.



HARDWARE LIST		
4*16mm screw	Drawer slides	
F  6PCS	E-1  2PCS	

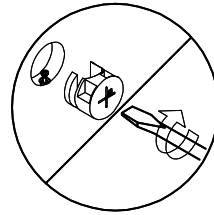
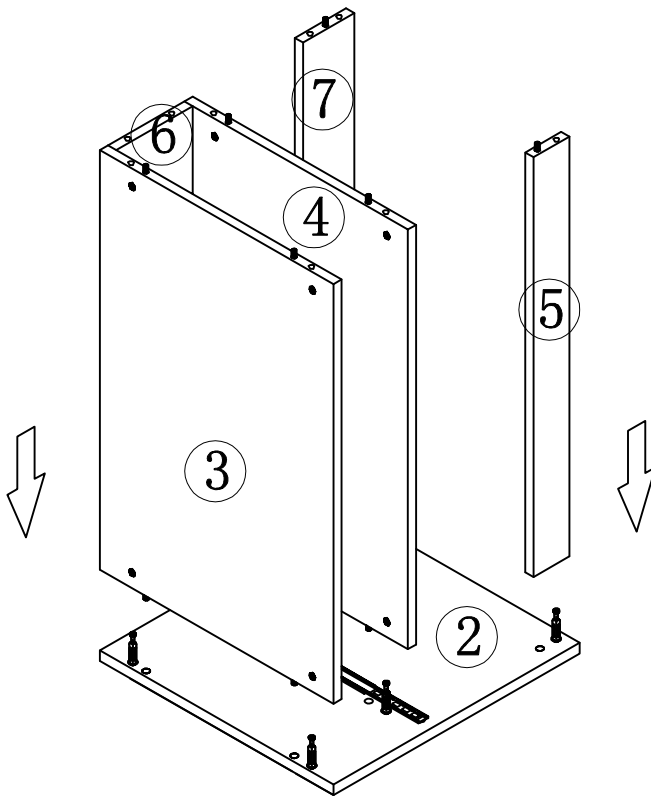

# STEP 5

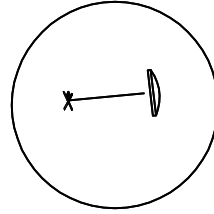

1. Connect No. 3-4-5-6-7 panel to No. 2 panel tightly with the three-in-one eccentric wheel.



2. Cover the mounting hole of the eccentric wheel with a three-in-one sticker.

HARDWARE LIST		
Three-in-one eccentric wheel A  9PCS	Three-in-one sticker C  9PCS	

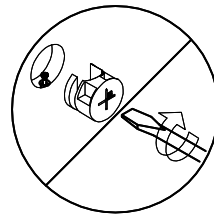
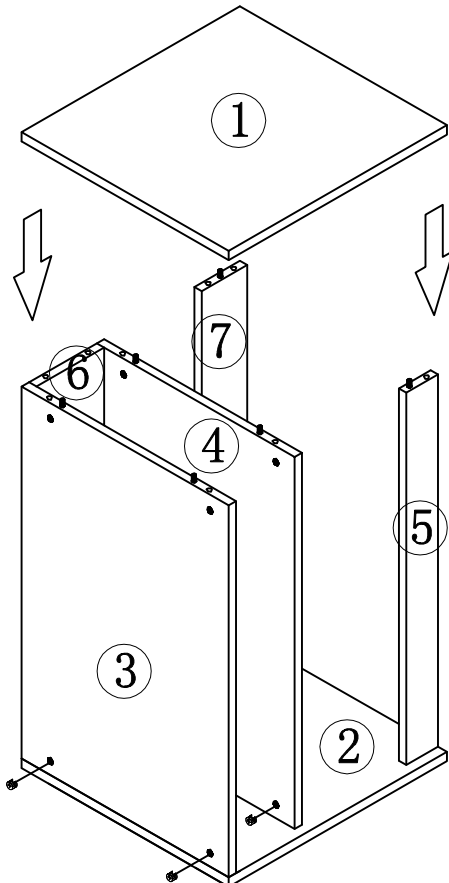

# STEP 6

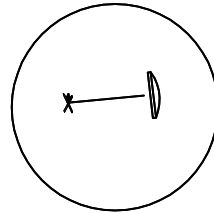

1. Connect No. 1 panel to No. 3-4-5-6-7 panel tightly with the three-in-one eccentric wheel.



2. Cover the mounting hole of the eccentric wheel with a three-in-one sticker.

HARDWARE LIST		
Three-in-one eccentric wheel A  9PCS	Three-in-one sticker C  9PCS	

# STEP 7



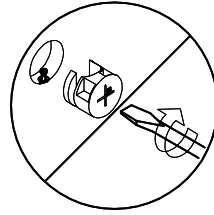
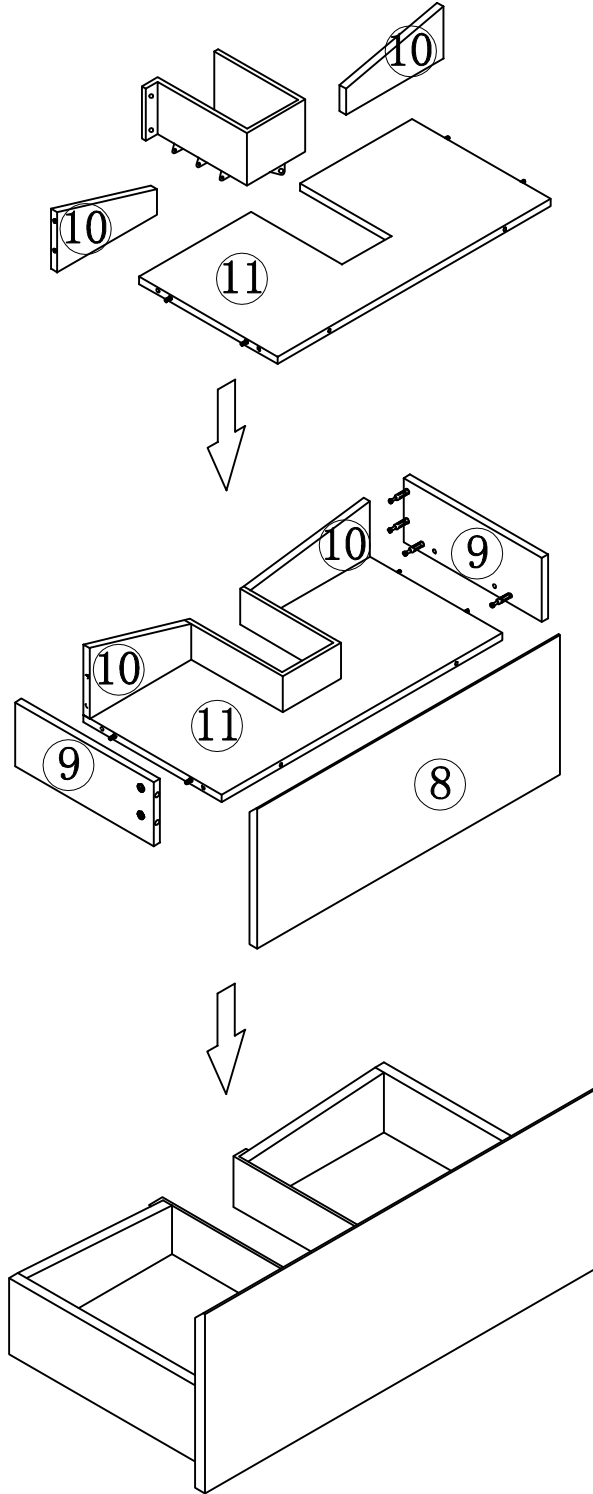

1. Install the Drawer U-shaped plastic with 4\*16mm screws.

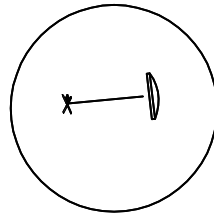

1. Install No. 8-9-10-11 panels with the three-in-one eccentric wheel tightly.



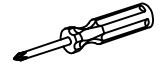

2. Cover the mounting hole of the eccentric wheel with a three-in-one sticker.

HARDWARE LIST		
Three-in-one eccentric wheel A  14PCS	Three-in-one sticker C  14PCS	
Drawer U-shaped plastic G  1PCS	4*16mm screw F  10PCS	

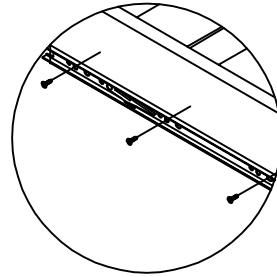
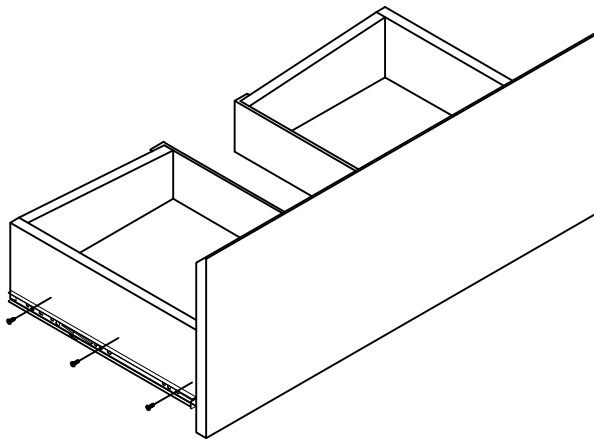
# STEP 8

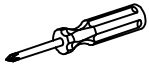

1.Lock the spare drawer slide block to the drawer.

HARDWARE LIST		
4*16mm screw	Drawer slides	
F  6PCS	E-2  2PCS	

# STEP 9

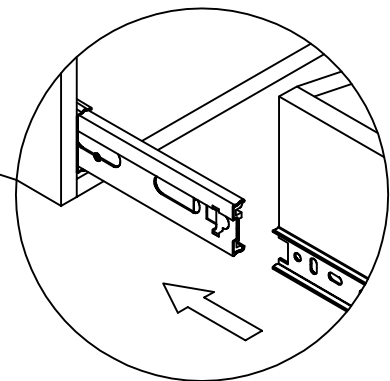
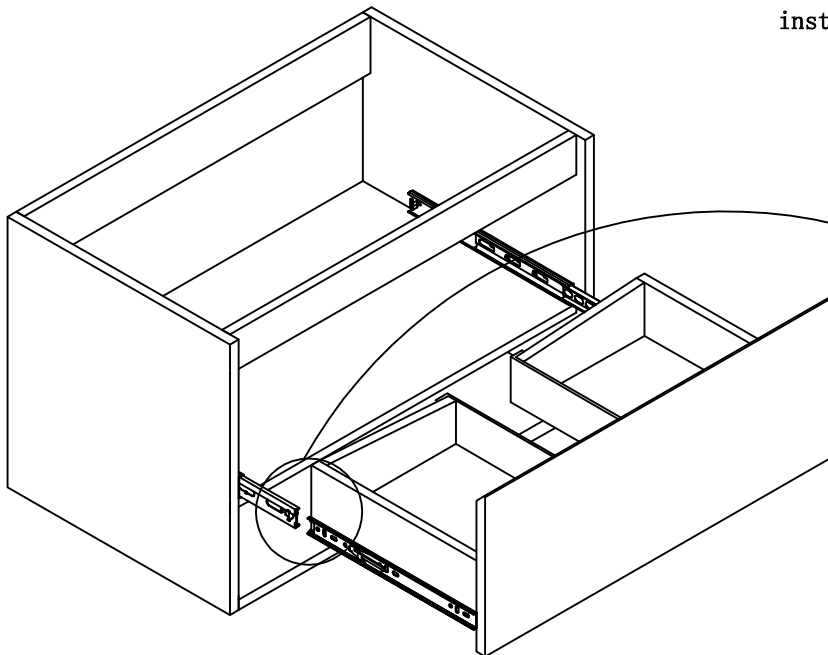

1.Align slide block with the trough on the guide rail, press the snap switch and press it forward to install the drawer.

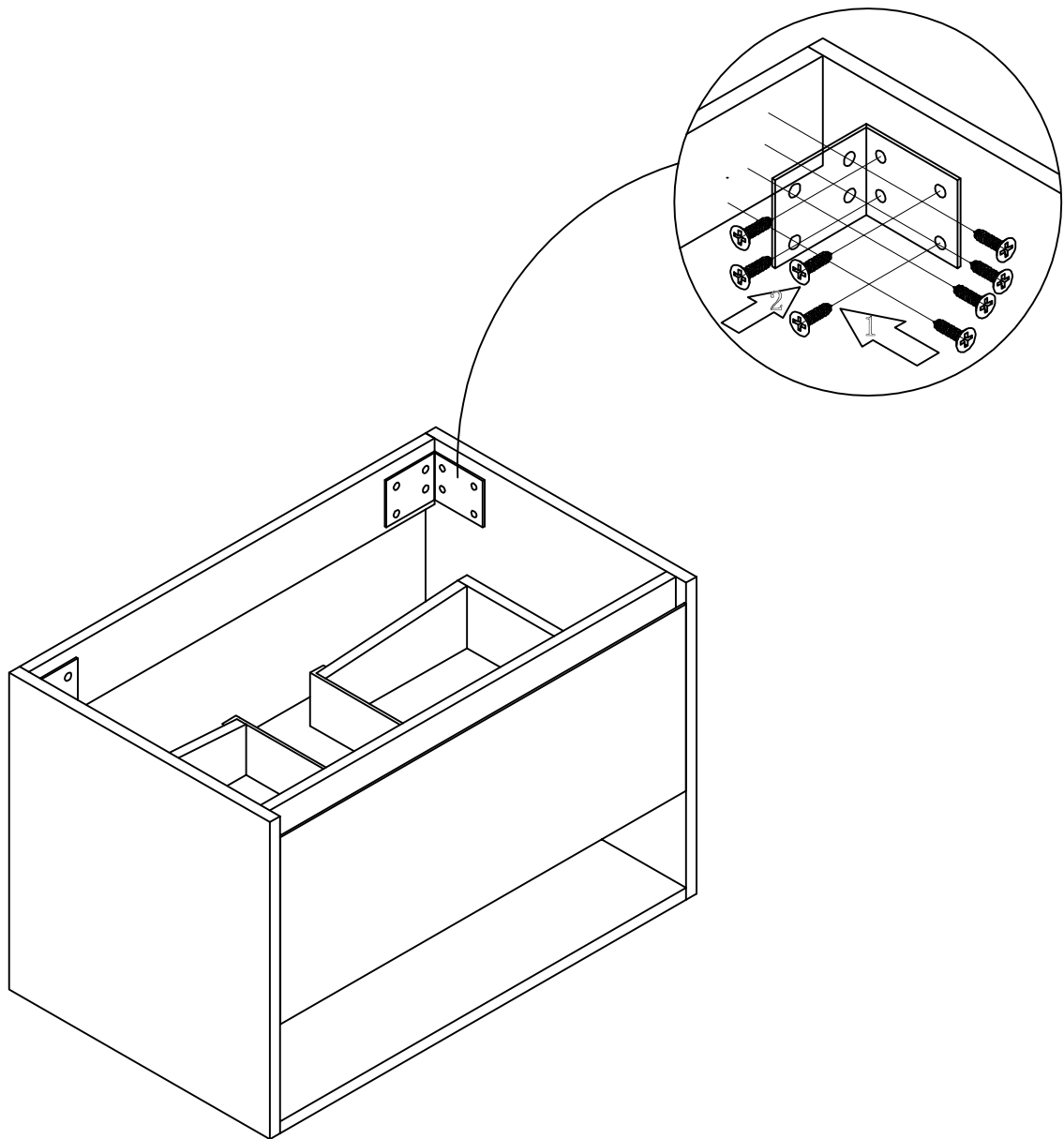

# STEP 10

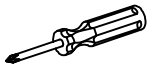

1. Install white angle bracket with 4\*16mm screws.

HARDWARE LIST		
4*16mm screw	Drawer slides	
F  16PCS	H  2PCS	



**Choking hazard-Small Parts :** This unit contains small parts, not for children under 3 years.

**Tip-over hazard :** Secure finished unit to wall stud using L-Bracket and wall screw (#10\*1.5"W/out provided). If a wall stud is not neccessible , Consault your local hardware store for appropriate mounting hardware . Failure to properly install will result in product collapse or tip-over. Serious injury can occur .