



Lumary

USER MANUAL

Model:L-CFL20J1

Lumary Outdoor Ceiling Fan Light Pro

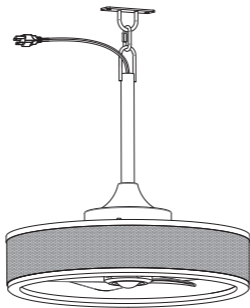

Need a instruction video?

Please scan the QR code and view it.

If the QR code fails, contact our support team at support@lumary.tech.

BASIC ACCESSORIES



Ceiling Bracket x1



O-ring x1



Plug cord x1



Canopy x1



6 inch Downrod x1



10 inch Downrod x1

PARTS FOR REMOTE CONTROL BRACKET



Remote Control x1



Bracket x1



Expansion rubber plug x2



ST3*25 Screw x2

PARTS FOR CEILING BRACKET

Wooden Panel



ST4*40 Screw x2



Washer x2

Concrete Wall



M6*60 Expansion bolts x2

IMPORTANT SAFETY INSTRUCTIONS

Pre-Installation Preparation	<ul style="list-style-type: none">• Ensure the mobile device is running iOS 17 or later (iOS) or Android 12 or later (Android). Connect to a 2.4GHz Wi-Fi network; 5GHz networks are not supported.
Electrical Safety	<ul style="list-style-type: none">• Always turn off power before installing or servicing the fan. The fan must be installed in a circuit with a wall-mounted isolation switch. Use only replacement parts recommended by the manufacturer. Read all instructions and safety information before installation. Disconnect power, remove fuses, or turn off circuit breakers before installation.
Physical Safety	<ul style="list-style-type: none">• Mount the fan directly to structural framing or a junction box labeled acceptable for fan support (minimum 35 lbs / 15.9 kg).• Do not bend blade arms during installation. Keep objects away from rotating blades.• Chemical Burn HazardO: Keep batteries secure and out of children's reach.
Usage & Maintenance	<ul style="list-style-type: none">• Supervise children when using the appliance. Children aged 8+ and individuals with reduced capabilities require guidance.• Supervise children during cleaning/maintenance.• Do not use solid-state fan speed controls or rheostats.
Compliance	<ul style="list-style-type: none">• Ensure electrical connections comply with local laws and the National Electrical Code (NEC). Hire a qualified electrician if unfamiliar with wiring (or consult DIY manuals). Install in a location with unobstructed blade rotation and at least 7 feet above the floor. Use a metal junction box secured directly to the building structure to support the fan's weight (minimum 35 lbs).
Professional Installation	<ul style="list-style-type: none">• Hire a qualified electrician for installation if unfamiliar with wiring. Secure all connections to prevent fan detachment.

This table organizes critical safety information into clear, concise categories (e.g., compliance with U.S. electrical codes, child safety, and professional guidance) to help users prioritize and follow instructions effectively.

Fan Doesn't Work	<ul style="list-style-type: none">• Make sure the power switch is on. Check the circuit breaker to ensure the power is turned on. Make sure the blades spin freely. Turn off power from the circuit breaker, then loosen the canopy and check all the connections according to the wiring diagram.
Excessive	<ul style="list-style-type: none">• Make sure the blades are properly installed on the blade iron posts. Turn the power off, support the fan carefully, and check that the hanger ball is properly seated.
Remote Control	<ul style="list-style-type: none">• Re-pair the remote control, power cycle the fan by toggling the wall switch (or circuit breaker if needed). Within 10s, Press the switch button twice and the light will breath.
Remote Only Works Close to Fan	<ul style="list-style-type: none">• Replace battery.
Fan Blade Wobbling	<ul style="list-style-type: none">• Please check the central cap of blades and turn clockwise to tighten.

If the problem is not listed, please email customer support at support@lumary.tech

- Lumary's products don't recommend that you use dimmers because flicker may occur during use.
- Make sure your mobile device meets the following requirements:
For iOS: Ensure your device is running iOS 17 or higher.
For Android: Ensure your device is running Android 12 or higher.
- Ensure that you are connecting to a 2.4GHz Wi-Fi network as Lumary devices are not compatible with 5GHz networks.

TOOLS NEEDED (NOT INCLUDED)



Ladder



Screwdriver



Wire Stripper

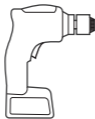

Drill



9/64" Drill Bit



It is recommended to have a partner when installing the ceiling fan.

1. We recommend having two people work together for a smoother and safer installation.
2. To enhance safety, use a hook to temporarily hang the fixture by its edge or secure the fan with a safety rope during installation. This precaution helps prevent accidental drops that could cause damage to the fan or surrounding objects.

If you need assistance during installation, feel free to reach out to our customer support team at support@lumary.tech — we're here to help.

PENDANT MOUNT INSTALLATION



WARNING: To avoid possible electrical shock, before installing your ceiling fan, disconnect the power by turning off the circuit breakers to the outlet box associated with the wall switch location.

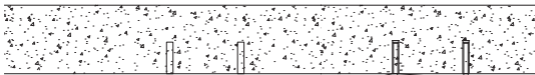

1. Concrete Wall



For concrete wall:

- Use a power drill to make holes in the wall.
- Secure the mounting bracket using the M60 expansion screws.



2. Wooden Panel

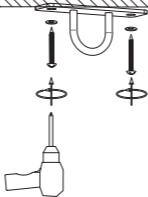

For wooden panel:

- Secure the mounting bracket using ST4×40mm screws and washers.

ASSEMBLING THE DOWNROD



⚠ WARNING: FAN FALL HAZARD

To prevent serious injury:

- Always tighten setscrew with screwdrivers.
- Do not hand tighten setscrew.
- Check the setscrew is tight using screwdrivers each time you change fan direction.

1

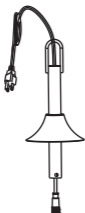

Step1

Select a downrod from 6/10 inch.
Across the power cord through the rod and canopy.
Connect the male and female connectors, then
tighten the nut on the waterproof plug.

2

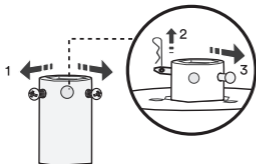

Step2

Remove the pre-installed
setscrew and downrod pin.

3

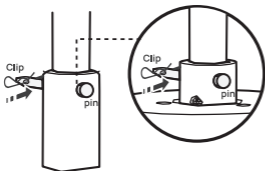

Step3

Carefully slide the downrod into
the yoke of the motor assembly,
align the holes in the downrod,
and reinstall the downrod pin and clip.

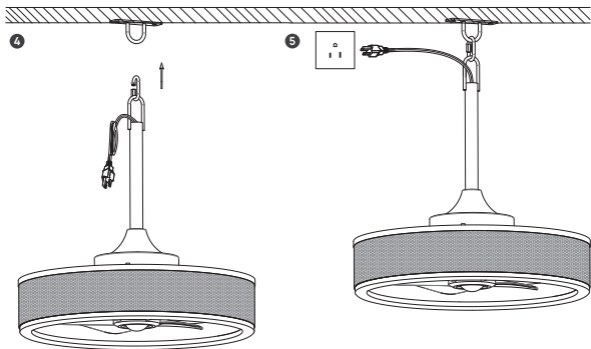

- Step4** Hang the light from the mounting bracket using an “O”-shaped hook, then tighten the nut on the hook to lock it securely in place.
- Step5** Plug the power cord into an outlet (ensure the outlet is installed in a dry, weather-protected location). Neatly route and secure the cord to prevent it from contacting or falling onto the fan blades, which could create a

What You Need:

- A Wi-Fi router supporting the 2.4GHz and 802.11b/g/n bands. 5GHz is not supported.
- A smartphone running iOS or Android.



1. Download the "Lumary" App from the App Store or Google Play.
2. Register a Lumary account. (Note: Please select your region and country.)
3. Supports only 2.4GHz Wi-Fi. The router can be configured to operate on separate bands: 2.4GHz and 5.0GHz.

Steps:

1. Turn on your smartphone's Bluetooth;
2. Open the Lumary App. In the top corner of the Devices screen, click "+" and select "Add Device" to confirm that the device is paired.
3. Each time the device without distribution network is powered on, confirm the light is breathing or blinking pairing mode; If not, you need to use the switch to reset: on-off-on-off-on;
4. Find the device, choose Wi-Fi and enter password, press "Next". Click "Add", and wait patiently. After that, click "Done", and the device is successfully added to the App.



Unable to connect the flight to Lumary App

- Ensure the ceiling fan lights is powered on.
- Check if your smartphone's Wi-Fi is enabled and connected to a 2.4GHz network (5GHz is not supported).
- Keep your smartphone close to the device during the first-time setup.
- Confirm that the Wi-Fi password entered is correct. Make sure the distance between the device and router is less than 50 feet (15 meters).
- If binding fails, try this method: Use two smartphones — one to create a hotspot and the other to connect to the hotspot and add the device via the Lumary App.
- If successful, it may indicate your router settings (MAC filtering or DHCP restrictions) are causing the issue.

The light lost connection

- Confirm the light is still powered on.
- Check if your home Wi-Fi network is stable.
- Try connecting the light to another phone's hotspot to isolate router issues.
- Ensure your smartphone is within 50 feet of the device.
- Delete the device in “My Devices” in the app, then re-add the light by following on-screen instructions.

Can I group same Lumary devices together?

- Yes, you can make same Lumary devices into a group:
 - * Schemes
 - * Same model
 - * General (Wi-Fi or Bluetooth devices)
- Grouping functions depend on device type and firmware version.

Name	Smart Outdoor Ceiling Fan Light Pro
Model	L-CFL20J1
Input Voltage	120VAC,60Hz
Wattage	Fan:20W LED:32W
Color Temperature	RGBAI +Tunable White(2700K-6500K)
CRI	80+
Lumens	3000lm(Bare Board Test)
Beam Angle	120°
Fan	1-6 Speeds
Rated Life	25000h

**RoHS**

Contains FCC ID:2ANDL-CB3S

Made in China

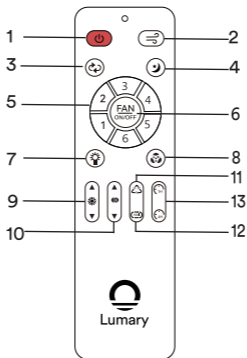

- | | |
|----------------------------------|-----------------------------------|
| 1: Turn on/off | 2: Wind mode: nature/soft |
| 3: Fan rotates: forward/ reverse | 4: Night light |
| 5: Fan speed: 1-6 Speeds | 6: Fan on/off, Press 5s to repair |
| 7: Turn on white color | 8: Turn on RGB color |
| 9: Change brightness | 10: Change color temperature |
| 11: Change color | 12: Change scenes-flowing colors |
| 13: Countdown Timing 1/4 Hours | |

How to reset remote control?

Power on the fan light, then long press the button  for 10s, the fan light will go into breathing state that the reset is done.

***The remote control that shipped with your fan is already paired.
If the remote doesn't control the light, follow the steps below.**

How to Pair the Remote with lumary ceiling fan light?

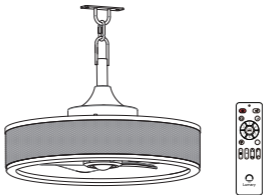

Power cycle the fan by toggling the normal switch(or circuit breaker if needed).

Method 1.Within 10s,Press the Button twice and the light will breathe.

Method 2.Within 10s,Press the Button about 5s and the light will breathe.

Note: If pairing fails, repeat Step 2.

How to reset lumary ceiling fan lights?

Method 1: By Manual Remote

Press the "  " button about 5S

Method 2: By Wall Switch

Toggle the switch: ON → OFF → ON → OFF → ON Each gap about 3-5s

***Reset Result:** If the light start breathing, it has been reset and is ready to pair.
If it does not pulse, the reset failed.

Installing one fan operating on multiple remote controls

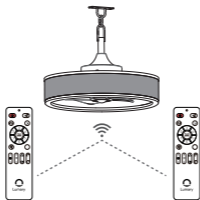

To have multiple remote controls operate one fan, you must pair each additional control to the receiver in the fan, the remote control that shipped with your fan is already paired.

Power cycle the fan by toggling the wall switch (or circuit breaker if needed). Within 10s, Press the **Button**  twice and the light will breath or blink.

Installing multiple fans operating on a single remote control

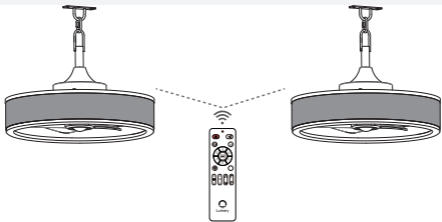

To have multiple fans operated by a single remote control, you must pair the remote control to each additional receiver. The receiver that shipped with your fan is already paired to the remote control.

Power cycle the fan by toggling the wall switch (or circuit breaker if needed). Within 10s, Press the **Button**  twice and the light will breath or blink.

This device complies with Part 15 of the FCC Rules. Operation is subject to the following two conditions:

(1) this device may not cause harmful interference, and (2) this device must accept any interference received, including interference that may cause undesired operation. Changes or modifications not expressly approved by the party responsible for compliance could void the user's authority to operate the equipment.

NOTE: This equipment has been tested and found to comply with the limits for a Class B digital device, pursuant to part 15 of the FCC Rules. These limits are designed to provide reasonable protection against harmful interference in a residential installation. This equipment generates uses and can radiate radio frequency energy and, if not installed and used in accordance with the instructions, may cause harmful interference to radio communications. However, there is no guarantee that interference will not occur in a particular installation. If this equipment does cause harmful interference to radio or television reception, which can be determined by turning the equipment off and on, the user is encouraged to try to correct the interference by one or more of the following measures:

- Reorient or relocate the receiving antenna.
- Increase the separation between the equipment and receiver.
- Connect the equipment into an outlet on a circuit different from that to which the receiver is connected.
- Consult the dealer or an experienced radio/TV technician for help.



1. Log in to Lumary App, tap the smart device and enter into, click "" in the top right corner.
2. Tap "Alexa" in Third-party Control.
3. Tap "Sign In With Amazon".
4. Tap "Allow".
5. Linked successfully, when add new device, there is no need to link again, just discover new device in Alexa.

Things you can say*:

"Alexa, discover my devices."

"Alexa, turn on the light/Fan."

"Alexa, set the fan light to orange."

"Alexa, set the fan light to 50%."

*Some commands require compatible devices.



1. Log in to Lumary App, tap the smart device and enter into, click "" in the top right corner.
2. Tap "Google Assistant" in Third-party Control.
3. Tap "Link with Google Assistant".
4. Click "Agree and link".
5. Linked successfully, when add new device, there is no need to link again, just discover new device in Google Home.

Things you can say*:

"Hey Google",and ask.

Things you can say*:





"Hey Google, turn on the light/fan."

"Hey Google, turn off the light/fan."

"Hey Google, set the fan light to orange."

"Hey Google, set the fan light to 50%."

*Some commands require compatible devices.

	<p>Adjustable Brightness & Color Temp 2700K-6500K, 0-100% Dimming Wake up to energizing cool light (6500K) for morning productivity. Wind down with warm amber (2700K) for cozy movie nights—no extra lamps needed.</p>
	<p>RGBAI & RGB Mode Transform your space instantly: vibrant rainbow for parties, soothing purple for yoga, or cinematic blue for Netflix marathons. Ditch boring single-color bulbs.</p>
	<p>Smart Timer Auto-off lights at bedtime to save energy. Simulate sunrise to wake up gently—no more jarring alarms or wasted electricity.</p>
	<p>Music Rhythm Sync Lights dance to your playlist! Throw a TikTok-worthy dance party or sync with white noise for meditation—your room becomes an extension of the vibe.</p>
	<p>Voice Control (Alexa/Google) "Alexa, dim the lights!" Control hands-free while cooking, working, or carrying groceries. Check lights remotely on vacation—peace of mind unlocked.</p>

24

HOURS

Quick Response

Quick Response

If there is any problem please check the Troubleshooting page . When you could not fix this, please contact us after-sale email, we will respond within 24 hours.

Please email the video of the problem and order ID to support@lumary.tech.

30

DAYS

Hassle-Free

Hassle-Free

After the purchase, if there any quality with devices, we can offer free return or replacement.

**2-YEAR
WARRANTY**



Friendly Reminder

Please rest assured that our service aim is to make customers 100% satisfied.

If there is any problem, please email us at support@lumary.tech.

1. If you have any questions about product settings or operations, please feel free to reach out to us!

Customer Service 7x24H: support@lumary.tech

2. "Ask a question" on the "Lumary" Seller Page.

● Sign into your Amazon account. Search the product about Lumary.



● Go to the product listing on click the Lumary Store.

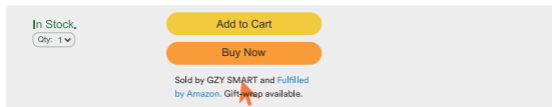

○ Click "Ask a Question" or "Contact the Seller"

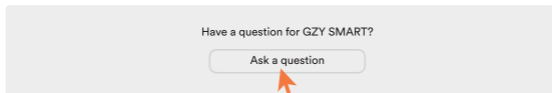

If you have any questions about product settings or operations, please feel free to reach out to us!

Customer Service Email:

support@lumary.tech

You can also find us on social media. Simply search for our username on your preferred platform, or scan the QR code to join the growing Lumary user community!

- Facebook: @lumary.official
- Instagram: @lumary.official
- YouTube: @lumary.official
- TikTok: @lumary.official
- X: @lumary_official
- Pinterest: @lumary_official
- Reddit: @Lumarysmartlight

Facebook



Facebook Group



Instagram



YouTube



TikTok



X

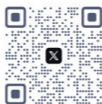

Pinterest



Reddit

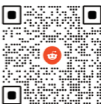

Can't connect? Need help?



HAVING AN EASY TALK TO US WITH REPLACEMENT
WE WILL FIX THE PROBLEM QUICKLY

Email Support:

support@Lumary.tech