

Recommended Maximum Weight

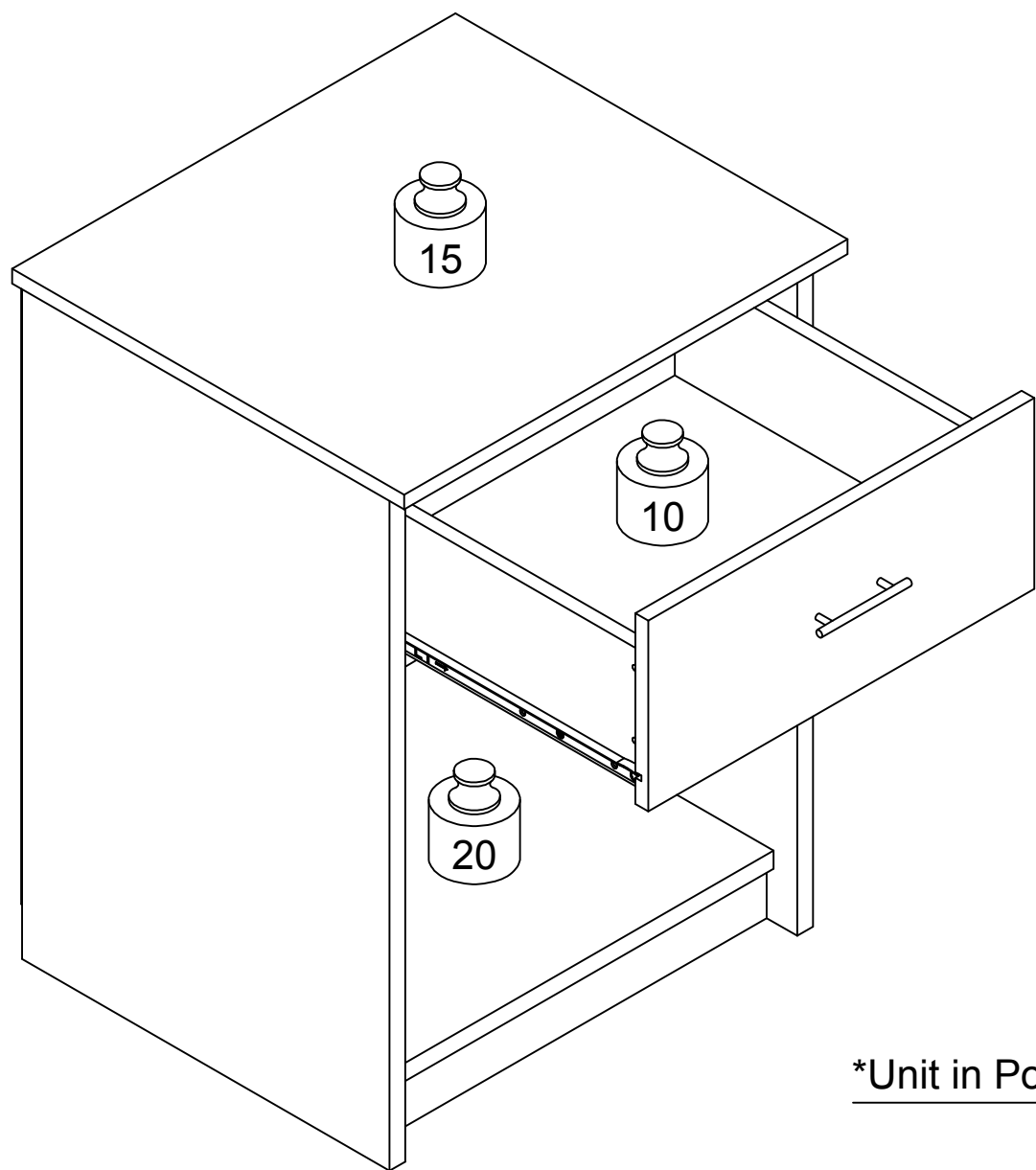

*Unit in Pound(lbs.)

WARNING:

>This unit has been designed to support the maximum loads shown. Exceeding these load limits could cause sagging, instability, product collapse, and/or serious injury.

>DO NOT allow children to climb on unit.

> Put heavier items on lower shelves.



Assembly Instruction

Nightstand With One Drawer

00:30

Approx. 30 minutes



Recomm. 1 Person

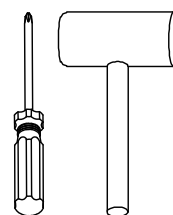

Tool Required

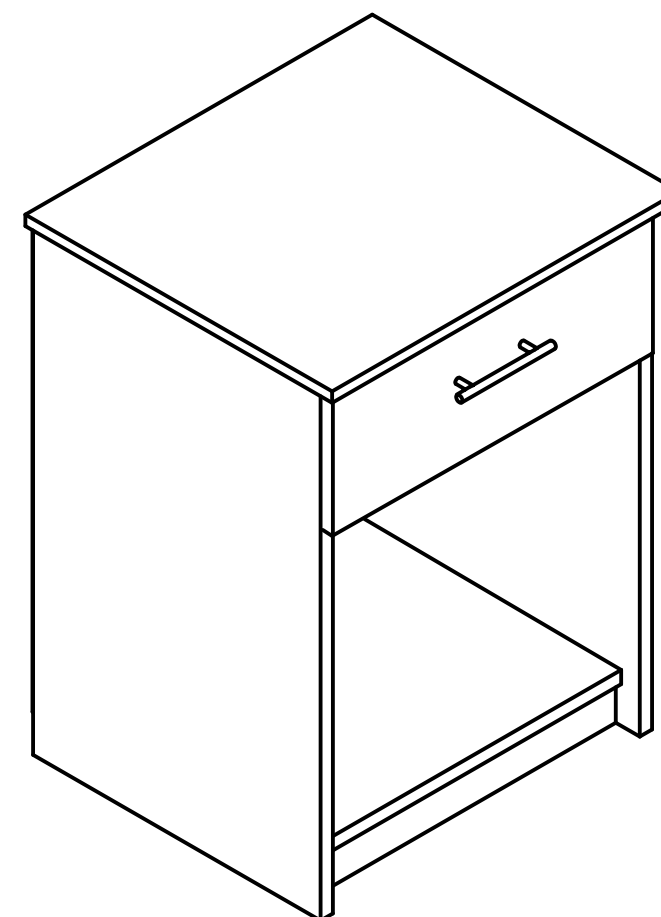

EXPLODED VIEW

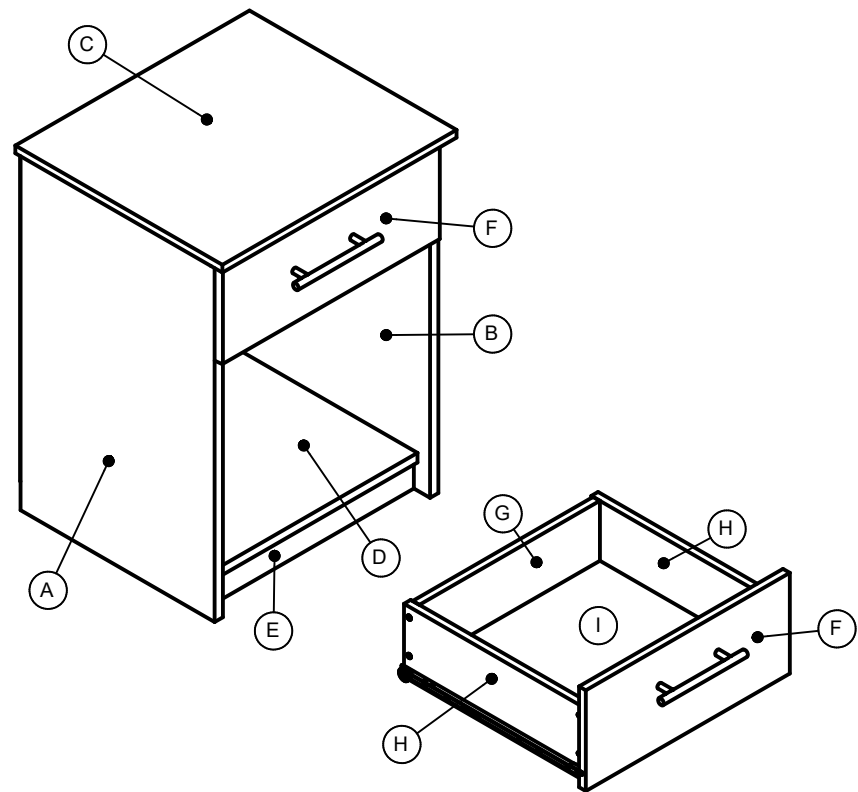

PARTS LIST

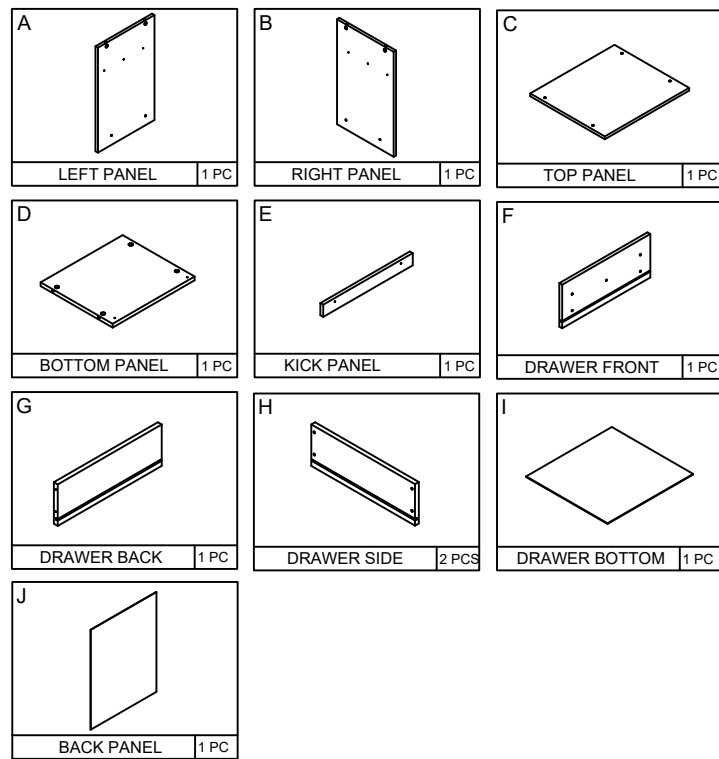

HARDWARE LIST

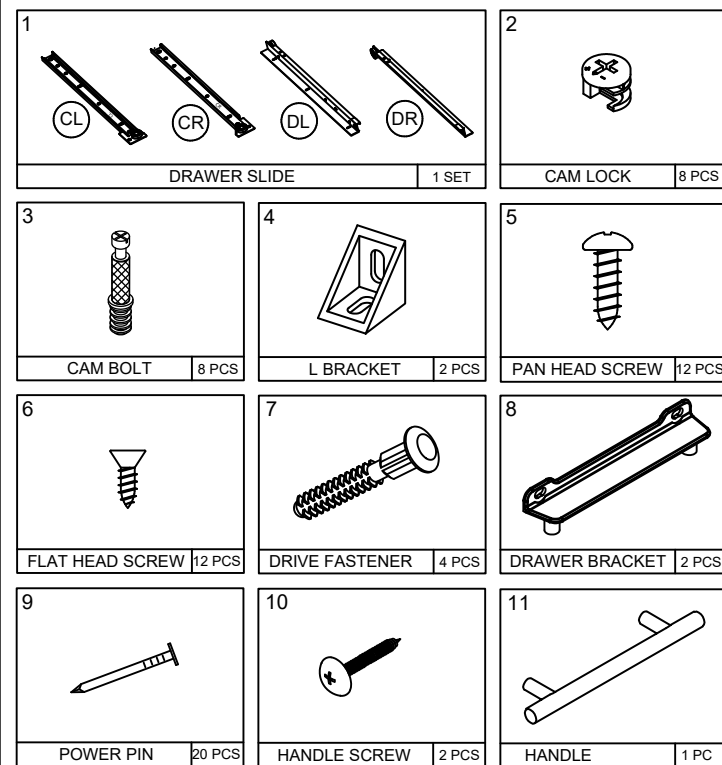

USEFUL HINTS BEFORE YOU START:

1. Read each step carefully before starting.
2. It is important that each step is performed in correct order to avoid difficulties.
3. Identify, soft and count the parts before assembly.
4. Assemble your furniture on packaging cardboard to prevent scratch or damage.
5. Clean the product with mild cleanser using soft damped cloth. Do not use harsh or abrasive cleanser.
6. Using incompatible hardware might cause damage to product.

STEP 9

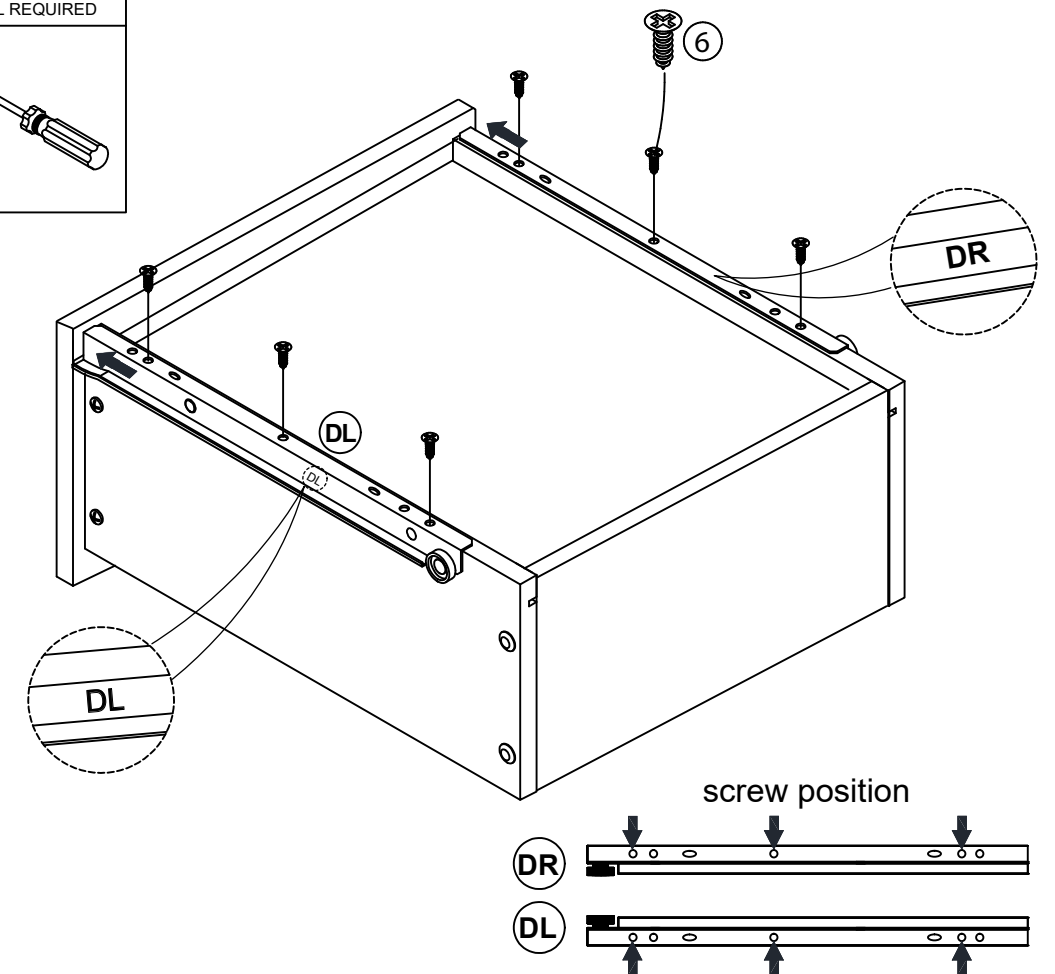
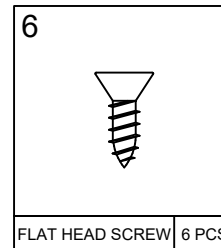
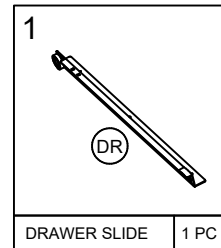
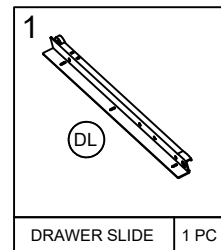
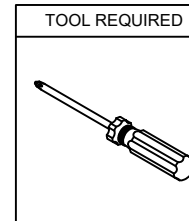

STEP 10

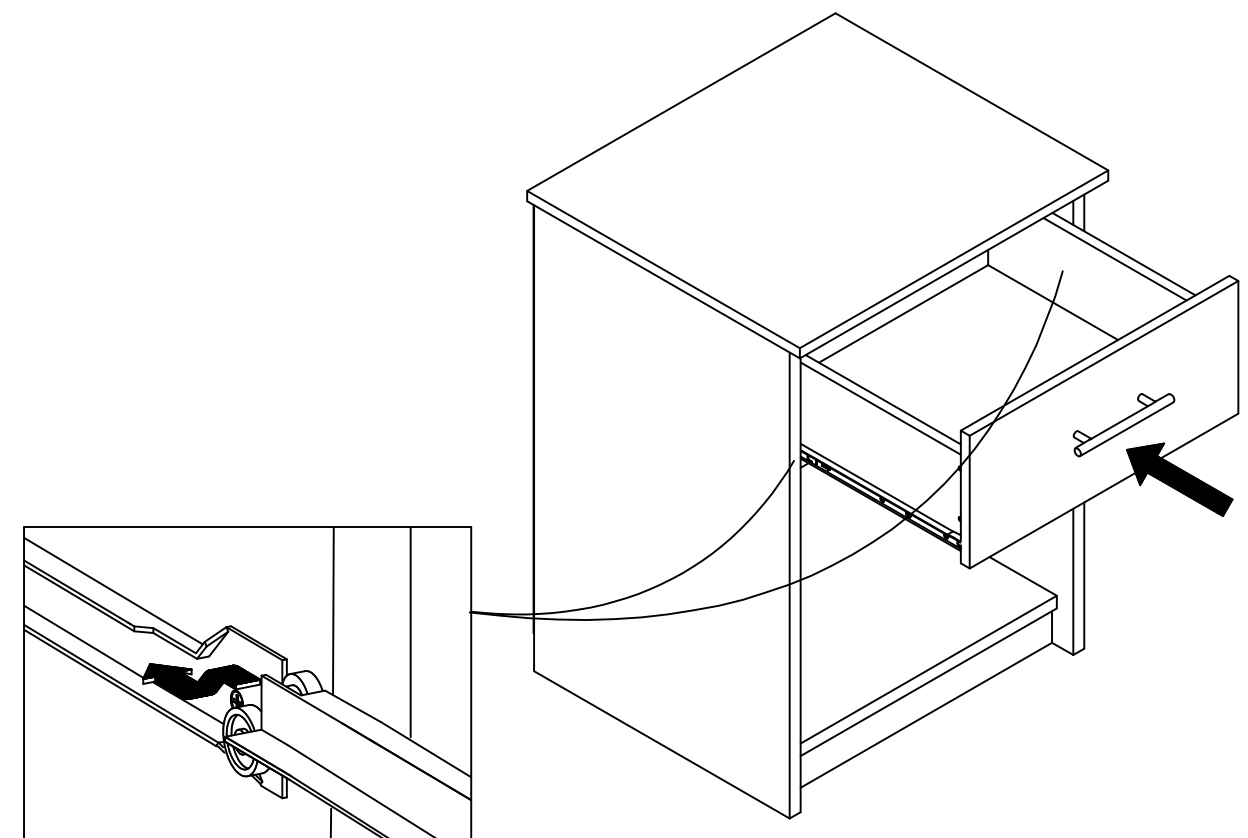

STEP 7

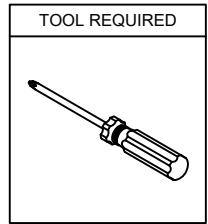
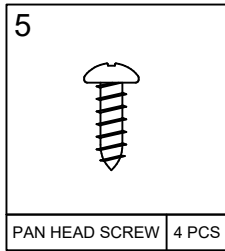
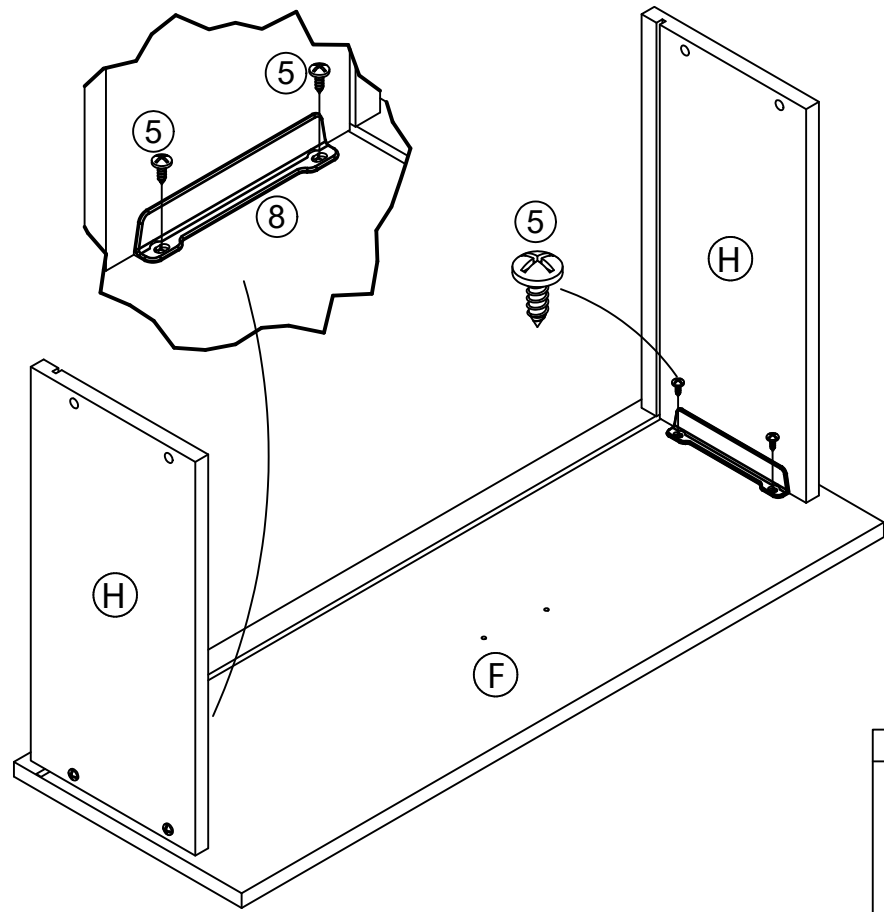

STEP 8

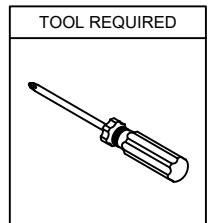
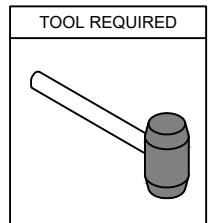
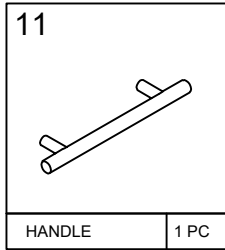
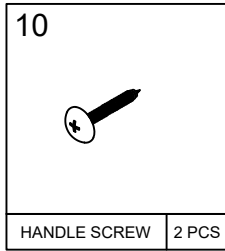
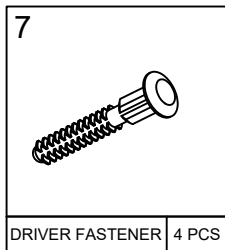
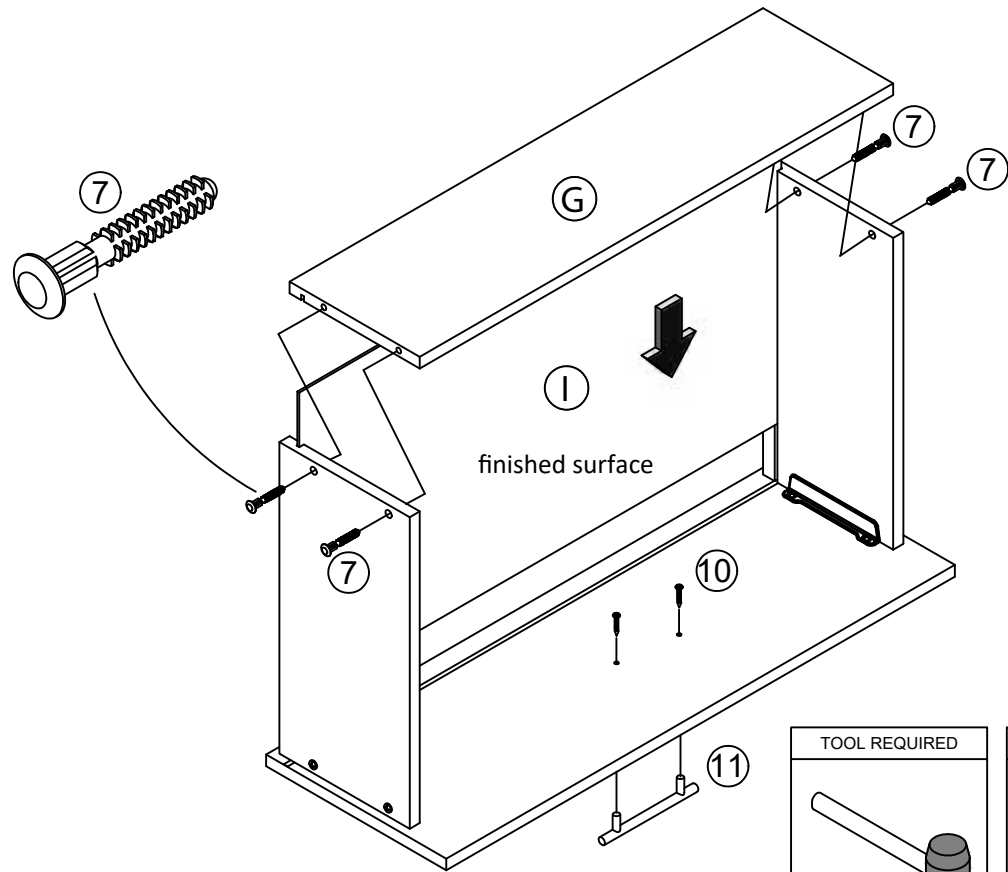

STEP 1

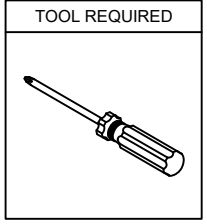
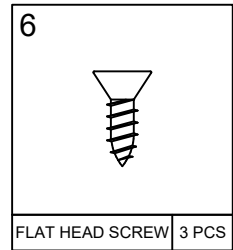
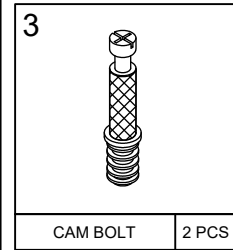
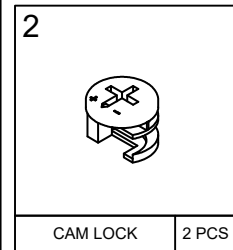
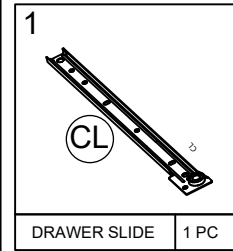
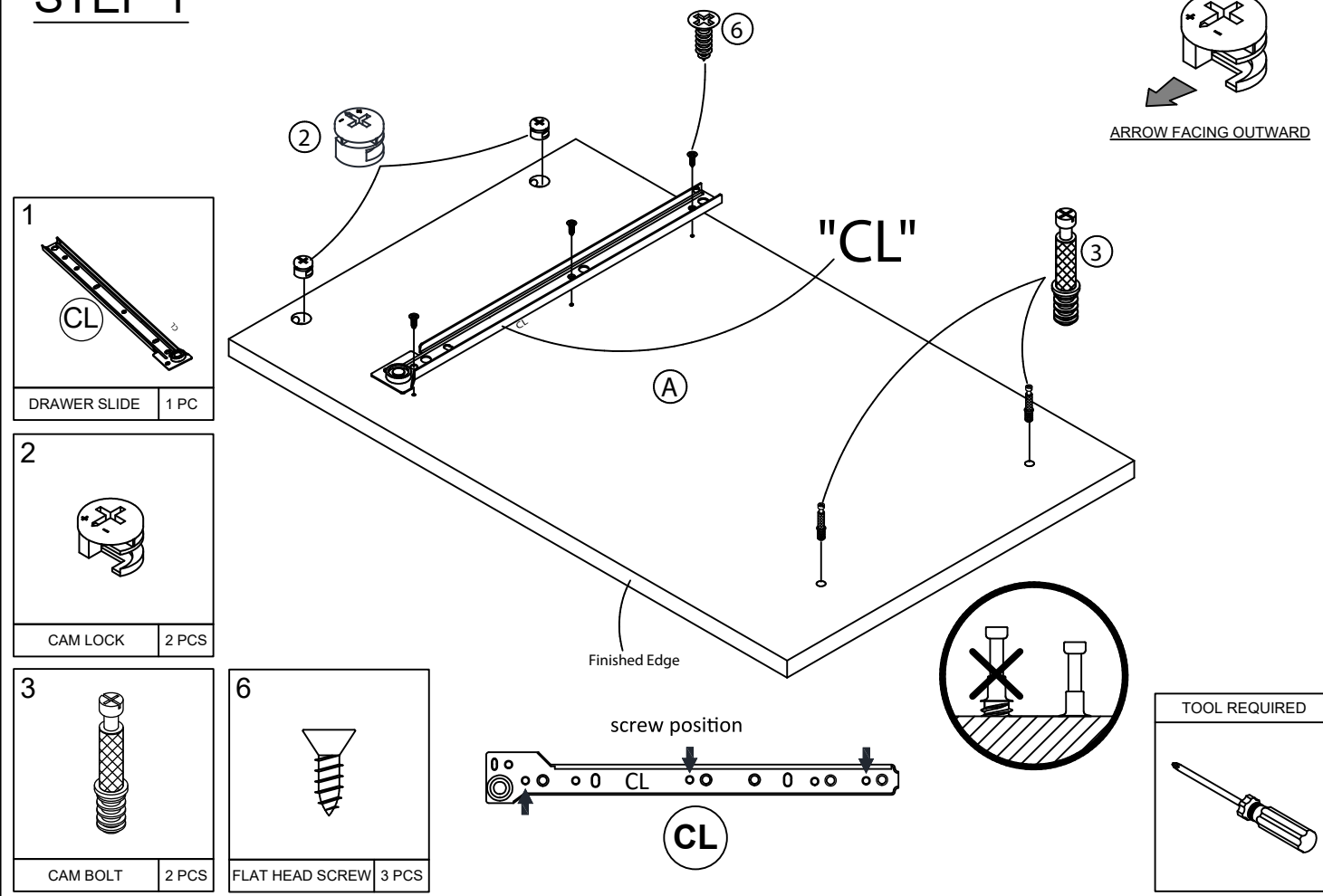

STEP 2

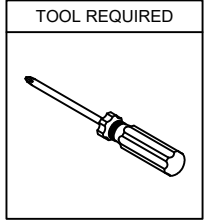
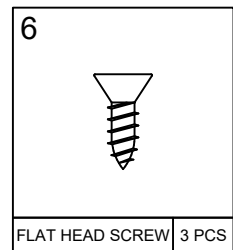
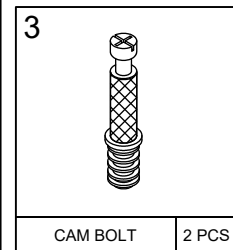
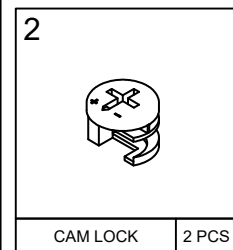
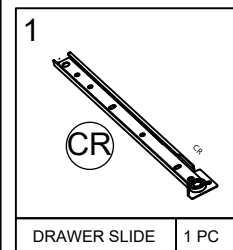
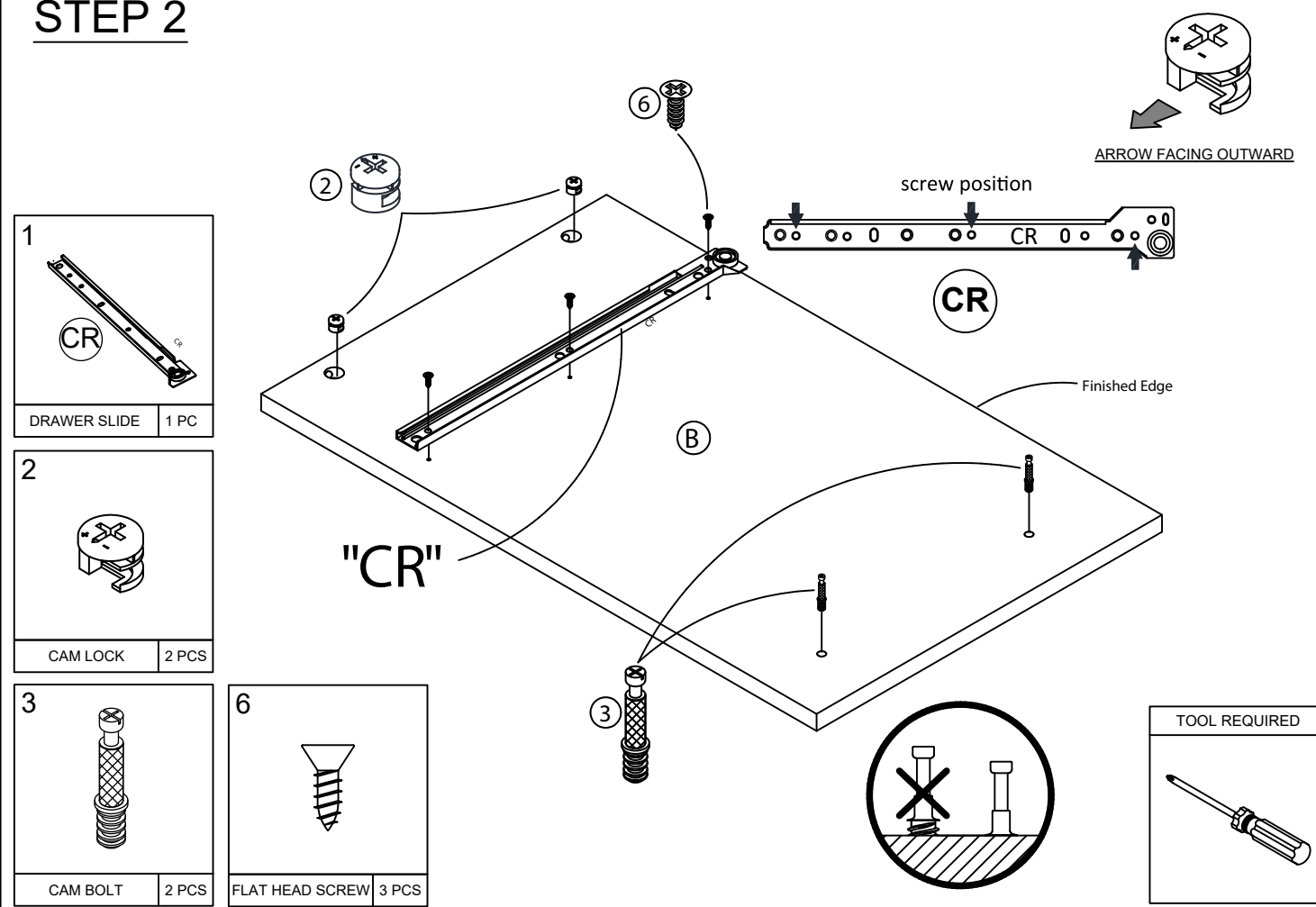

STEP 3

STEP 3.1

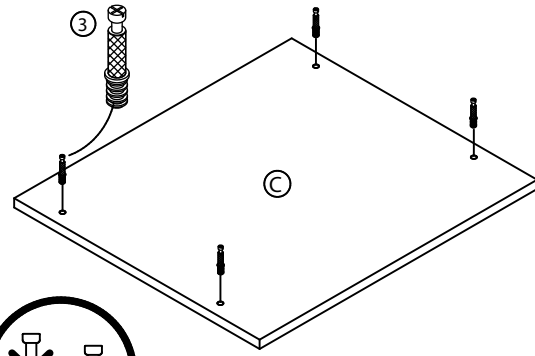

Finished Edge

STEP 3.2

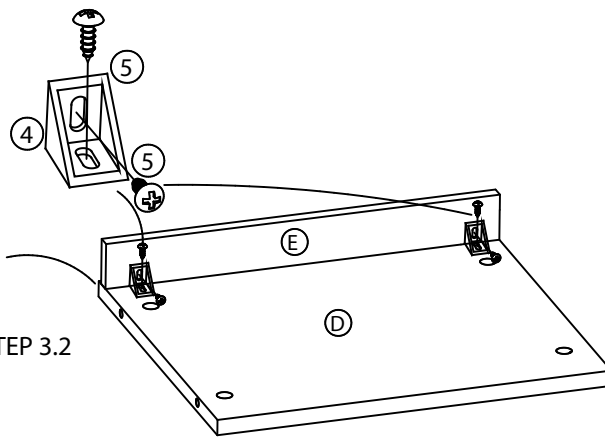

STEP 3.3

Finished Edge

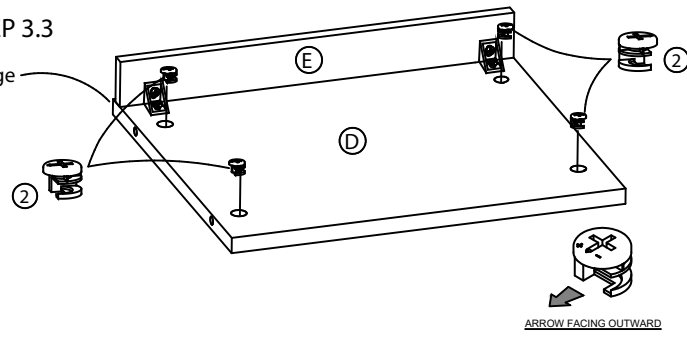

TOOL REQUIRED

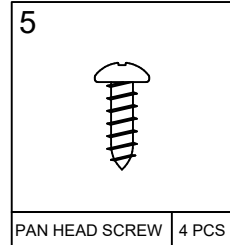
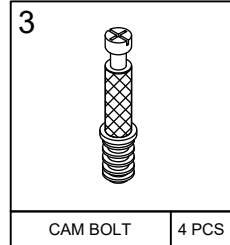
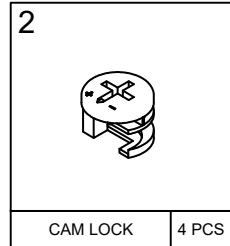
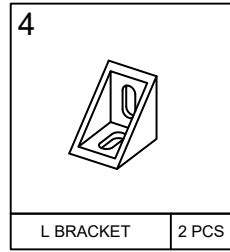
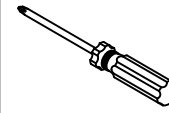

STEP 4

STEP 4.2

Finished Edge

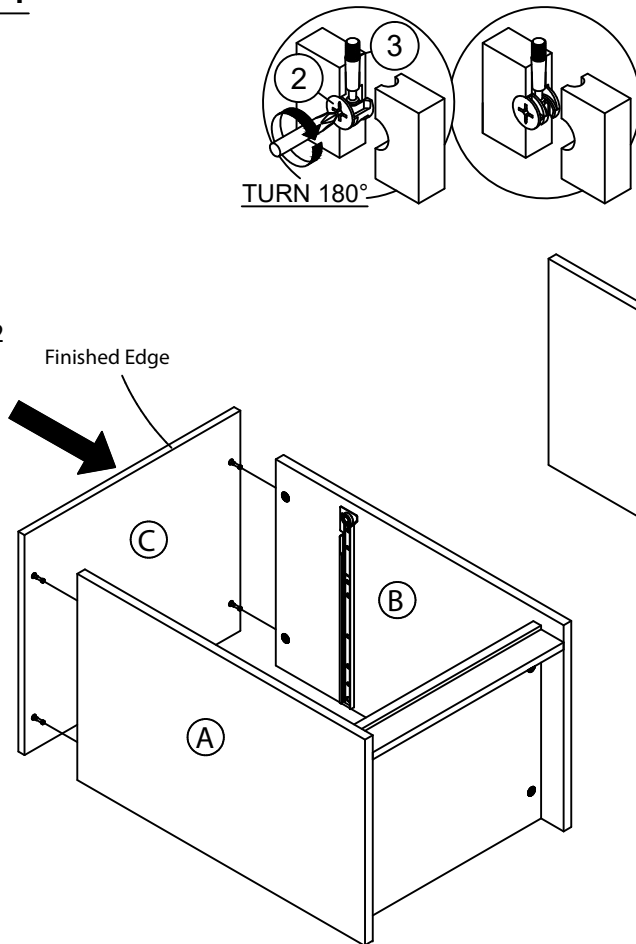

STEP 4.1

Finished Edge

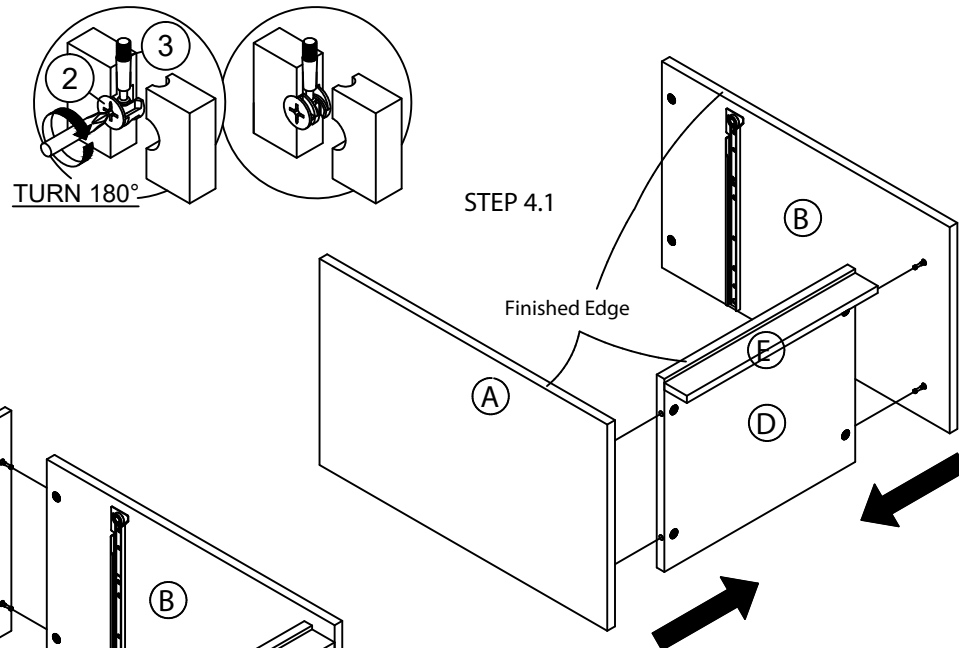

TOOL REQUIRED

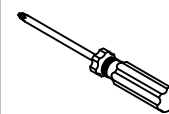

STEP 5

TURN 180°

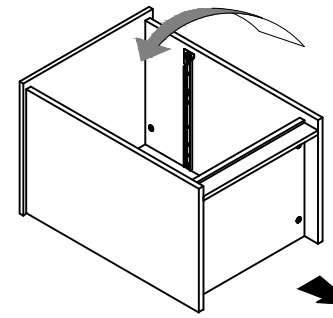

Unfinished Surface

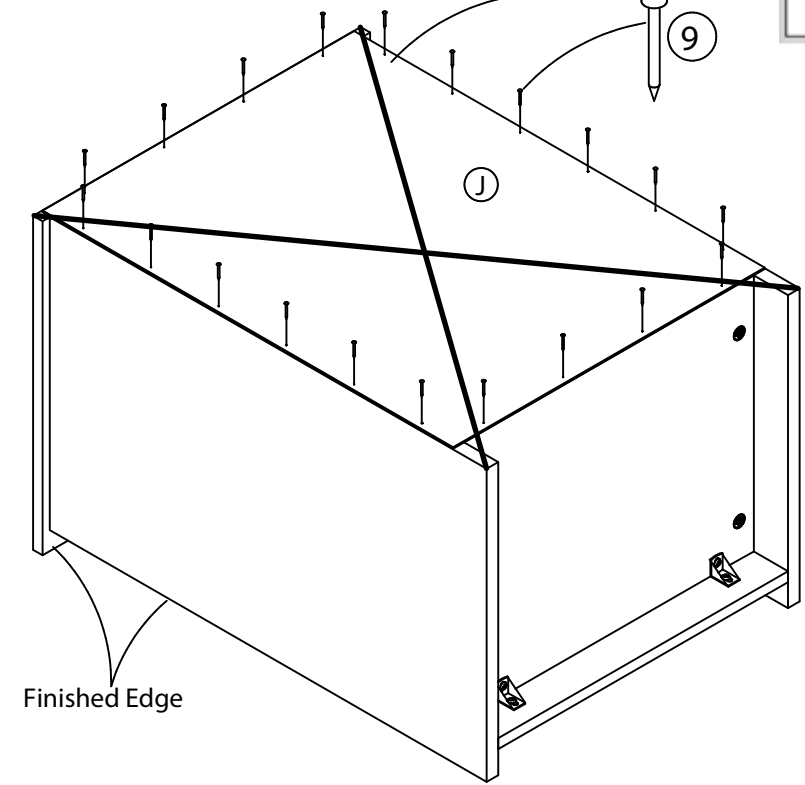

Finished Edge

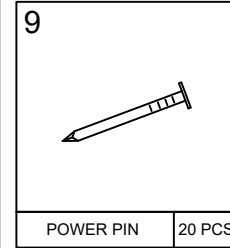

TOOL REQUIRED

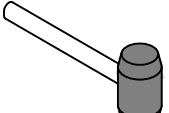

STEP 6

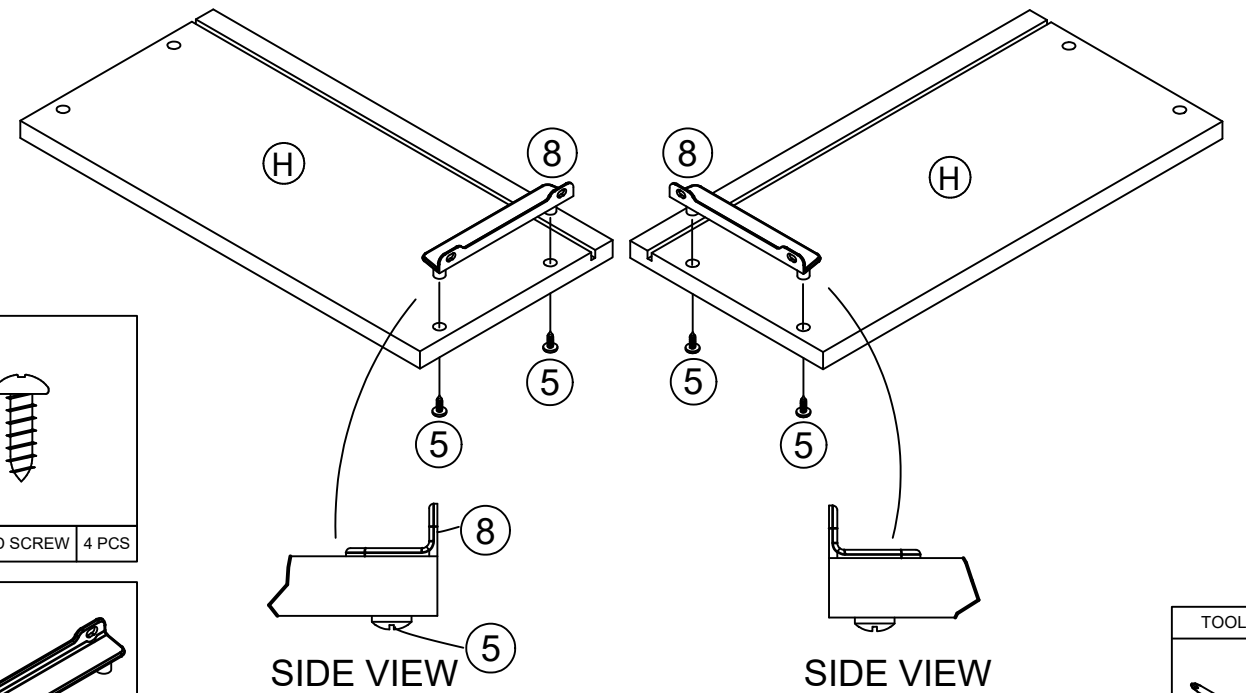
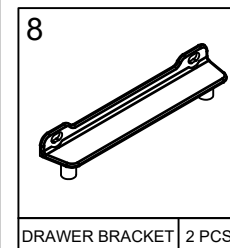
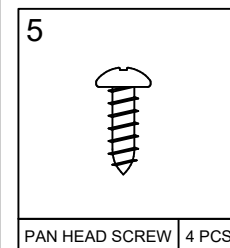

SIDE VIEW

SIDE VIEW

TOOL REQUIRED

