

STEP 3

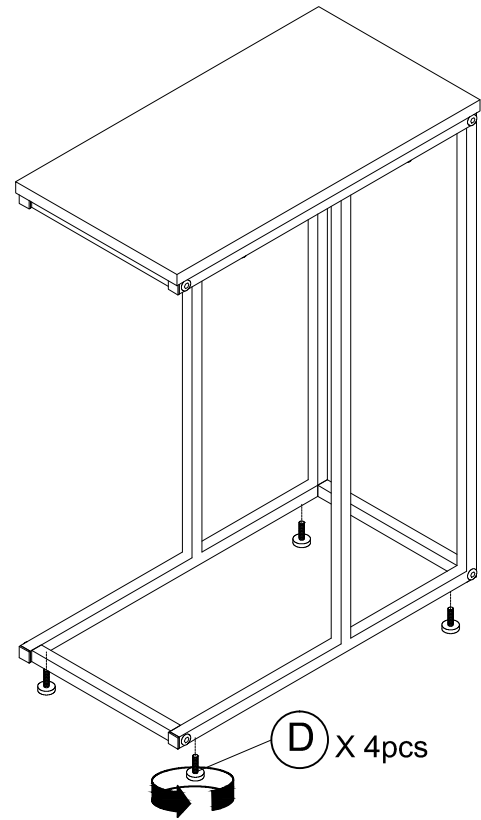

Recommended Maximum Weight

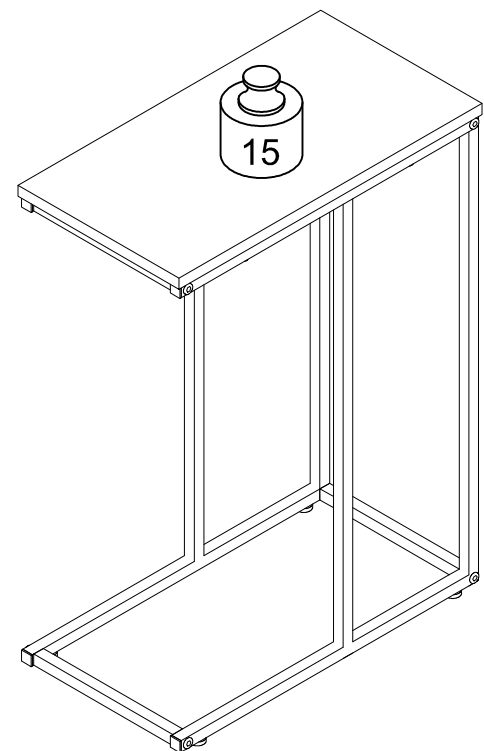

*Unit in Pound(lbs.)

WARNING:

- >This unit has been designed to support the maximum loads shown. Exceeding these load limits could cause sagging, instability, product collapse, and/or serious injury.
- >DO NOT allow children to climb on unit.
- > Put heavier items on lower shelves.

00:10

Approx. 10 minutes



Recomm. 1 Person

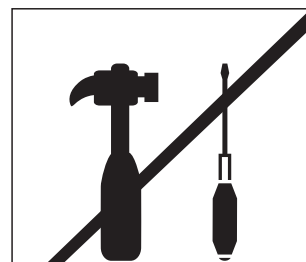





No Tools Required

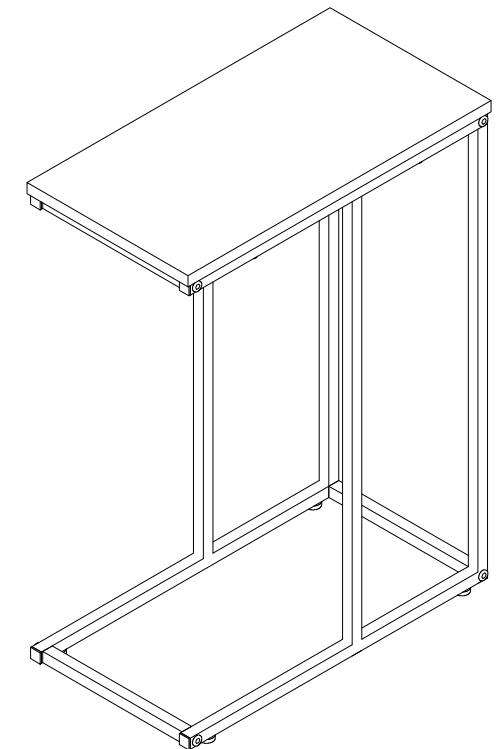

Assembly Instruction

Side Table

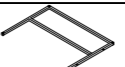

HARDWARE & PARTS LIST

NO	HARDWARE LIST	QTY
A	LONG SCREW 	8pcs
B	SHORT SCREW 	4pcs
C	ALLEN KEY 	1pc
D	SCREW LEG 	4pcs

NO	PARTS LIST	QTY
1	METAL FRAME 	2pcs
2	RAIL 	4pcs
3	TOP PANEL 	1pc

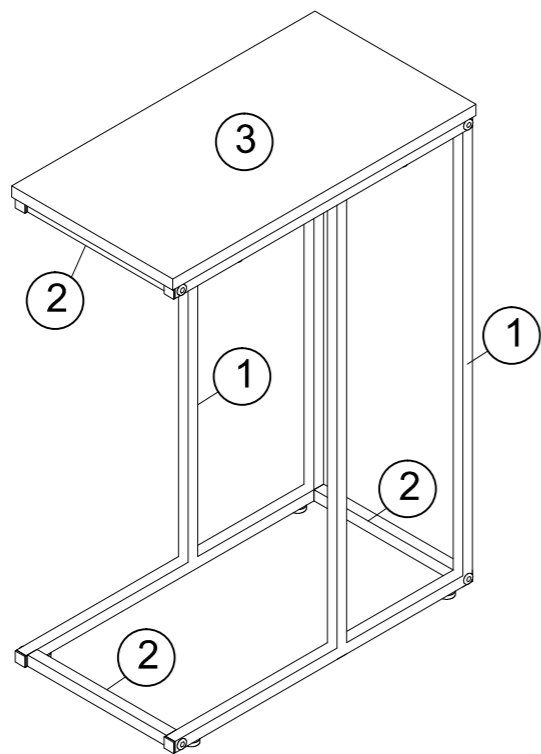

ASSEMBLY INSTRUCTIONS

BEFORE YOU BEGIN, PLEASE READ ASSEMBLY INSTRUCTION CAREFULLY, FOLLOW THEM STEP BY STEP.

STEP 1

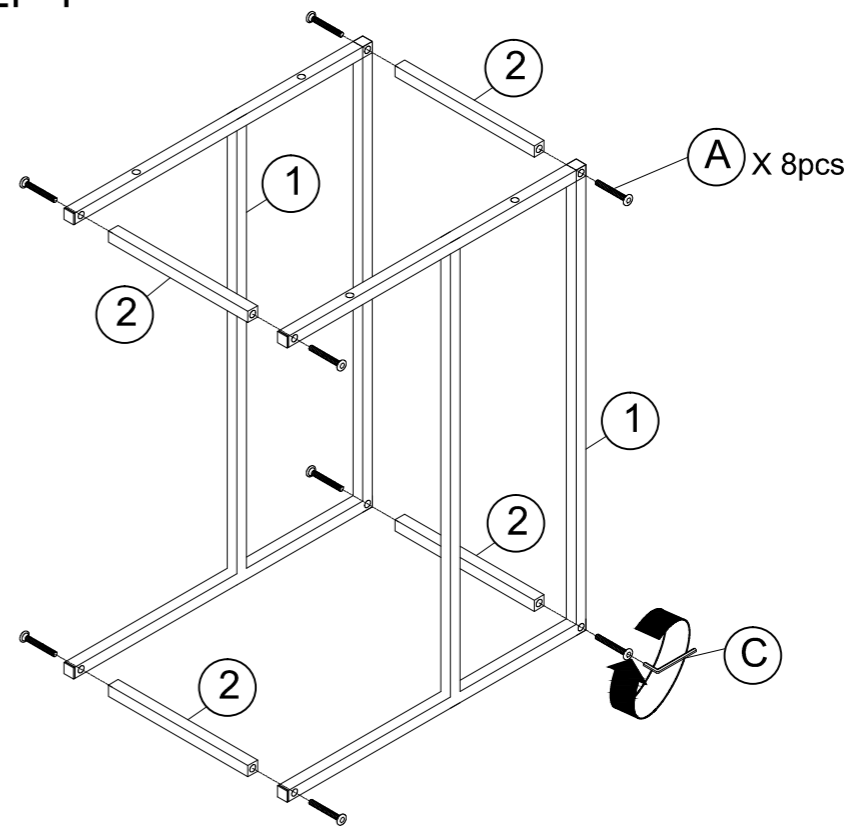

STEP 2

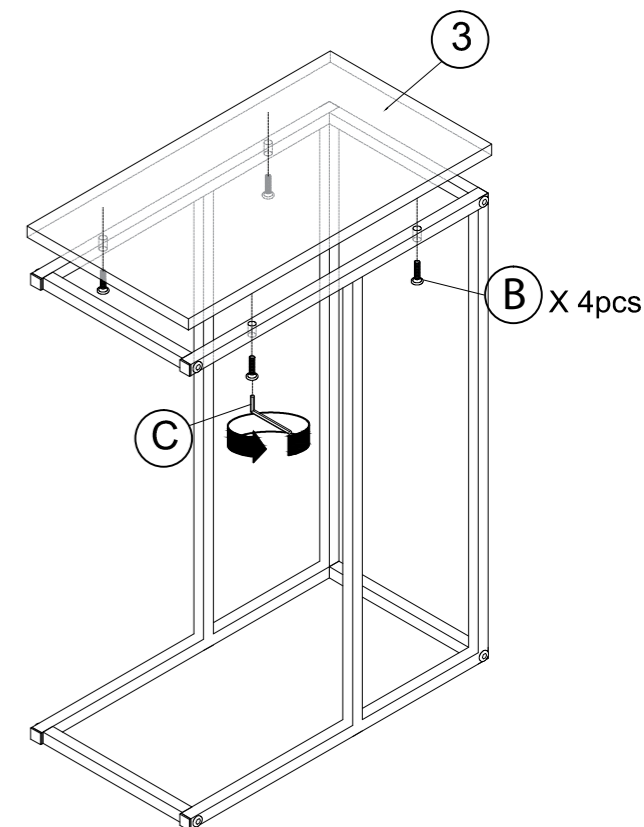

USEFUL HINTS BEFORE YOU START:

1. Read each step carefully before assembling.
2. It is important that each step is performed in correct order to avoid difficulties.
3. Identify, sort and count the parts before assembly.
4. Assemble your furniture on packaging cardboard to prevent scratch or damage.
5. Clean the product with mild cleanser using soft damped cloth. Do not use harsh or abrasive cleanser.
6. Using incompatible hardware might cause damage to product.