











# Assembly Instructions

**Caution : You must read this before you proceed**

## Care & Maintenance

- ⊘  ● Not for commercial use. For residential use only.
- ✓  ● Furniture may scratch floors. We recommend using furniture pads to protect your floors.
- ⊘  ● Do not put hot items directly on furniture surface.
- ⊘  ● Do not clean furniture with harsh cleansers or polish.
- ⊘  ● Do not place furniture under direct sunlight.
- ⊘  ● Do not place furniture near heating or cooling vents.
- ⊘  ● Do not write on furniture without a padded barrier to protect the surface.
- ⊘  ● Do not place furniture outside . For indoor use only.
- ⊘  ● Stains may be removed with mild soap solution and damp cloth.
- ⊘  ● Children should not climb or jump on the furniture.





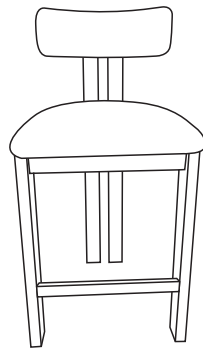

- Dust and pick-up spills using a clean, non-colored, lint-free cloth.

Please look in carton for hardware packs and legs.  
Sets often ship in multiple boxes and may arrive a day or two apart.



## Counter Stool

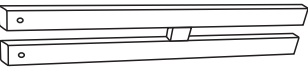

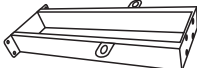
### Parts List

Label	Picture	Description	QTY
A		Back	1
B		Seat Cushion	1
C		Back Leg	1
D		Front Leg	1
E		Connection Metal	1

### Hardware

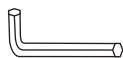
Label	Picture	Description	QTY
①		Bolt (M6x45mm)	3
②		Bolt (M6x18mm)	13
③		Washer (6x18x1.5mm)	7
④		Allen Wrench (5mm)	1
⑤		Spare Leveller	1

# Assembly Preparation

Before Beginning Assembly :



A



B



C

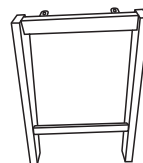

D

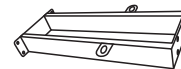

E



① x3



② x13



③ x7



④ x1



⑤ x1



- Read instructions, cover to cover-



- Have 2 adults on hand for assembly-



- Do not assemble on flooring or carpet-



- Assemble on a clean non-marring surface (packing foam)-



- Save all packaging until finished-

# Assembly Steps

## Overview

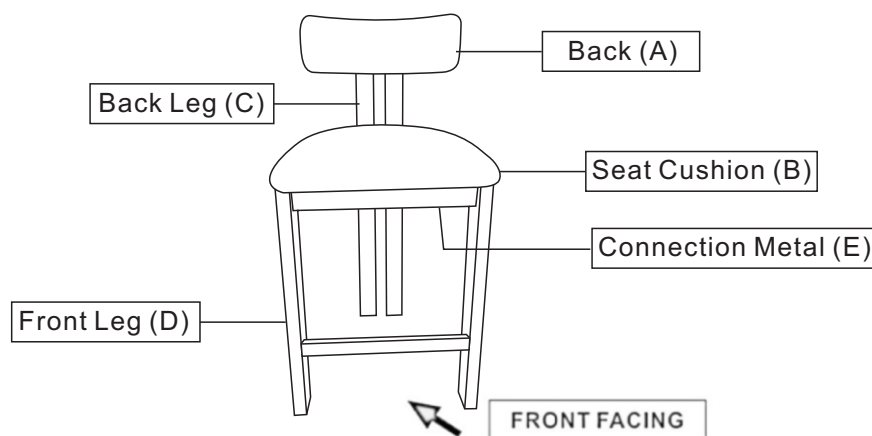

This Counter Stool has multiple parts and may require up to some 30 minutes to assemble. To give you an overview of the Counter Stool parts, the above picture is to help you put the various parts into perspective. Please read through the instructions below to familiarise yourself with the parts and steps before assembly.

## Step1

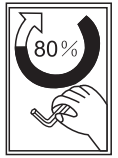
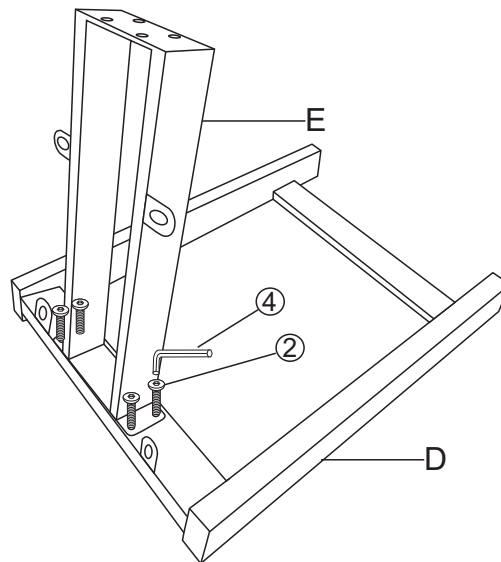

Attach the Connection Metal (E) to Front Leg (D) using the Bolt (2) with Allen Wrench (4) as pictured above.  
Do not fully tighten the Bolts.

## Step2

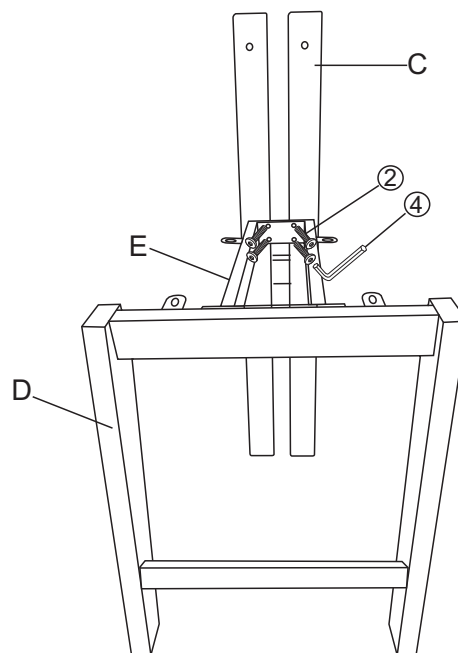

Attach the Back Leg (C) to the frame using the Bolt (2) with Allen Wrench (4) as pictured above.  
Do not fully tighten the Bolts.

## Step3

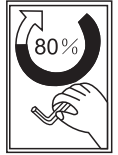
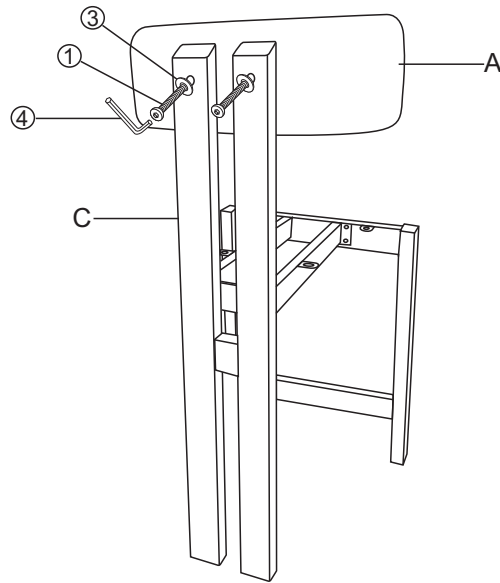

Attach the Back ( A) to Back Leg (C) using the Washer (③), Bolt (①) with Allen Wrench (④) as pictured above.  
Do not fully tighten the Bolts.

## Step4

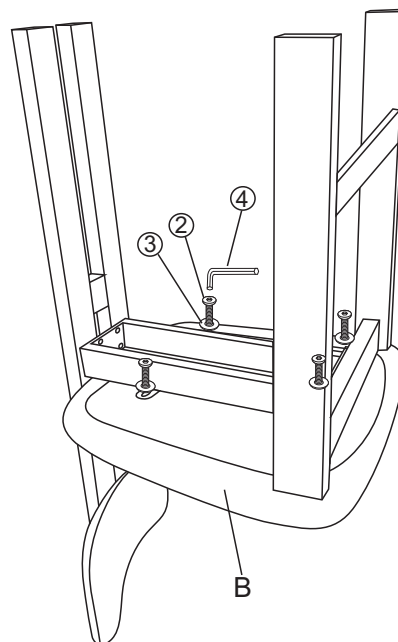

Attach the Seat Cushion (B) to assembled frame using the Washer (③), Bolts (②) with Allen Wrench (④) as pictured above.  
Fully tighten the Bolts

## Step5

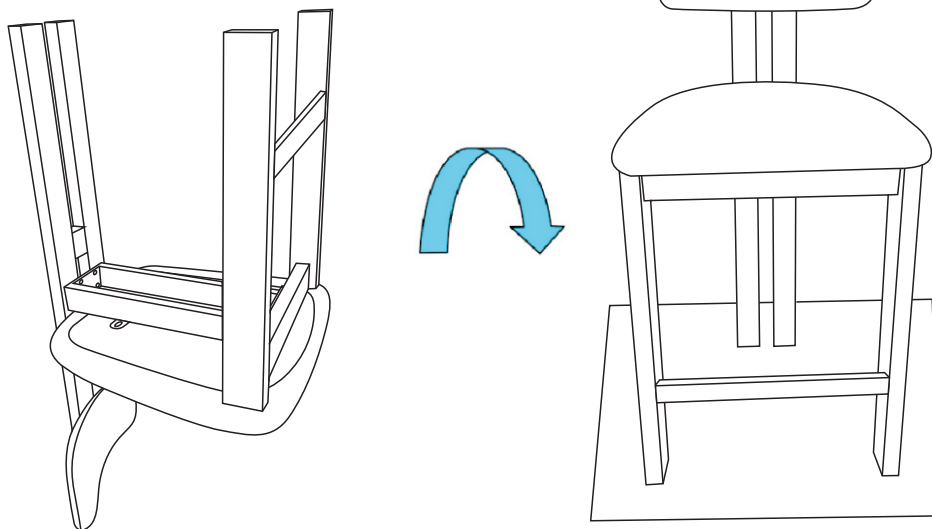

Stand the Chair up .

After checking the chair, if no problem, pls fully and securely, tighten all bolts, at all joints.

Place the chair on a **LEVEL SURFACE** to check for wobbles .

Adjust the levelers to ensure chair stability .

## Step6

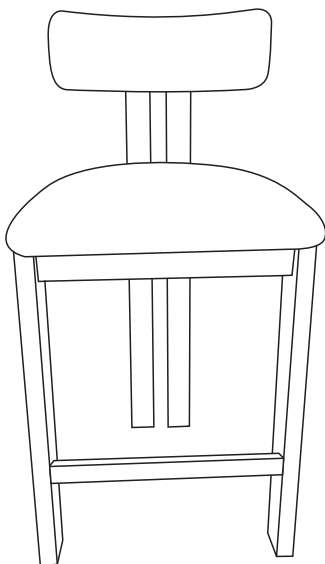

Your Chair is ready for use .

This chair can only be used on a flat, level surface.