

Instruction Manual

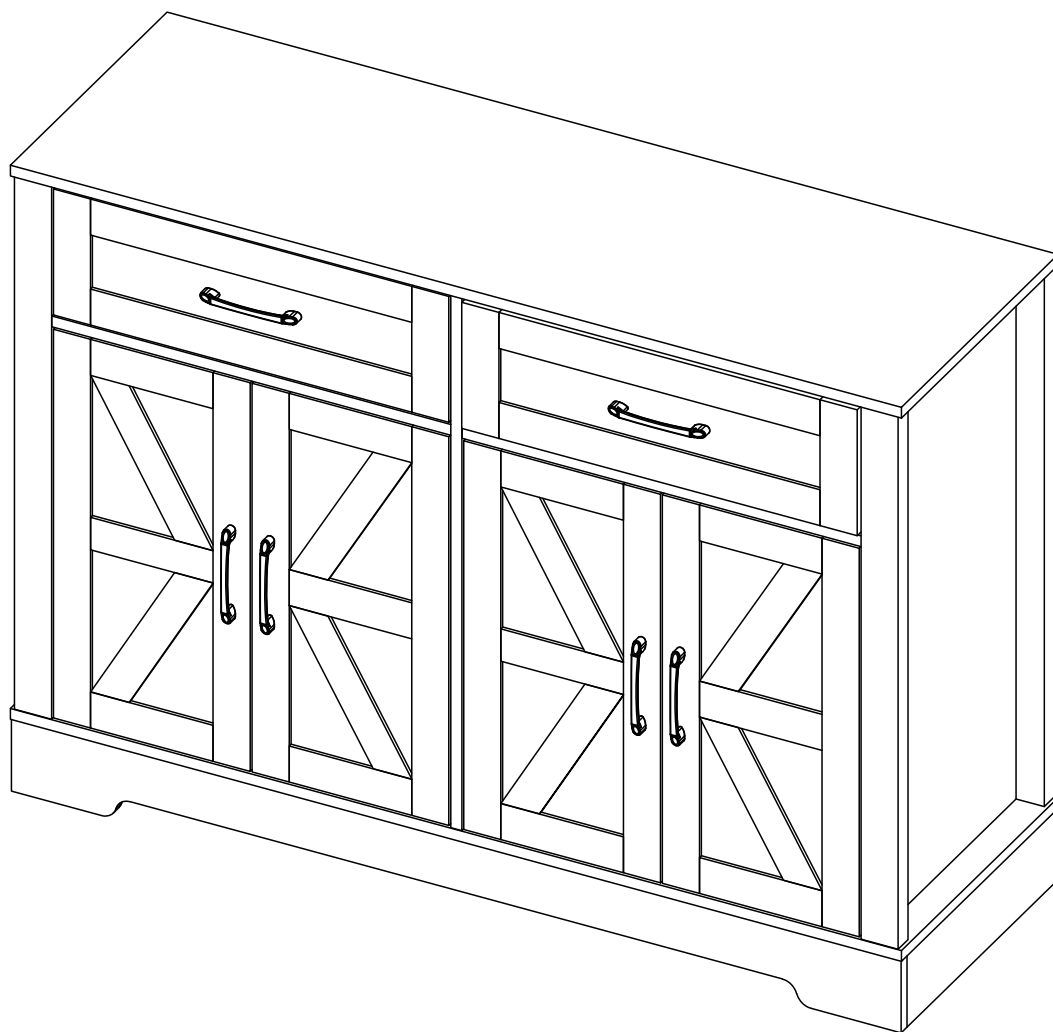

Cabinet

EN Thank you for purchase on our products. Please contact us if you have difficulty with assembly or need replacement parts. Our customer service is here to assist you.
Please attach your User Name or Order ID so that we can assist you better.



WARNING

The product must be assembled by adult before use.

Serious or fatal injury may occur from unexpected assembly or use.

1. During the assembly process, keep all parts away from babies or children.
2. Always securely fix this product to the wall. Make sure the wall area to be drilled is free from hidden electrical wires, water and gas pipes.
3. Use of tip-over restraints may only reduce, but not eliminate the risk of tip-over.
4. Unless specially designed to accommodate, do not set heavy objects on top of this product.
5. Place the heaviest items on the lowest shelf.
6. Never allow children to climb or bang on drawers, doors or shelves.

DE Vielen Dank für Ihren Kauf von uns Produkten. Bitte kontaktieren Sie uns, wenn Sie Probleme mit Montage haben oder Ersatzteile benötigen. Wir Kundenservice ist für Sie da.
Bitte geben Sie Ihren Benutzernamen oder Ihre Bestellnummer an, damit wir Sie besser unterstützen können.



WARNUNG

Der Produkt muss vor Gebrauch von einem Erwachsenen zusammengebaut werden.

Bei unerwarteter Montage oder Verwendung können schwere oder tödliche Verletzung auftreten.

1. Legen Sie in den Montageprozess alle Teile weg von Babys oder Kindern.
2. Befestigen Sie dieses Produkt immer sicher an der Wand. Um sicherzustellen, dass der zu bohrende Wandbereich entfernt von verdeckten Stromkabeln, Wasser- und Gasleitungen ist.
3. Die Verwendung von Kippsicherungen kann die Gefahr eines Kippens nur verringern, jedoch nicht beseitigen.
4. Setzen Sie bitte keine schweren Gegenstände auf dieses Produkt, es sei denn, dass das Produkt speziell für die Unterbringung konzipiert wird.
5. Legen Sie bitte die schwersten Gegenstände auf das unterste Regal.
6. Erlauben Sie nie Kindern, auf Schubladen, Türen oder Regale zu klettern oder zu knallen.

IT Grazie per aver acquistato i nostri prodotti. Se avete domande, non esitate a contattarci. Se riscontrate problemi di assemblaggio o devi sostituire parti, il nostro team di assistenza clienti ti aiuterà.
Quando ci contatti, includi il tuo nome utente o l'ID ordine in modo che possiamo fornirti un aiuto migliore.



AVVERTIMENTO

Il prodotto deve essere assemblato da un adulto prima dell'uso.

L'inaspettato montaggio potrebbe provocare lesioni gravi o mortali.

1. Durante l'assemblaggio, metti tutti i parti fuori dalla portata dei bambini.
2. Sempre fissare saldamente questo prodotto alla parete. Assicurarsi che l'area della parete sia libera dai cavi elettrici nascosti, i tubi dell'acqua e del gas.
3. La restrizione punta-over può ridurre il rischio di punta-over ma non può eliminarlo.
4. A meno che con l'appositamente progettato, Non deponere gli oggetti pesanti sul piano superiore.
5. Posiziona le robe più pesante al piano inferiore.
6. Non permettere i bambini di scalare o battere i cassetti, le porte o gli scaffali.

FR Merci pour votre achat de nos produits. S'il vous plaît contactez-nous si vous avez des difficultés avec assemblage ou besoin de pièces de remplacement. Notre service client est là pour vous aider.
Veuillez joindre votre nom d'utilisateur ou votre numéro de commande afin que nous puissions vous aider au mieux.



ATTENTION

Le produit doit être assemblé par un adulte avant utilisation.

Des blessures graves ou mortelles peuvent survenir à cause de l'assemblage ou l'utilisation inattendue.

1. Pendant le processus de montage, gardez toutes les pièces loin des bébés et des enfants.
2. Fixer toujours sécuritaire ce produit au mur. Assurez-vous que la zone du mur à percer est libre de fils électriques cachés, de conduites d'eau et de gaz.
3. L'utilisation de dispositifs de retenue pour le renversement ne peut que réduire, mais pas éliminer le risque de renversement.
4. Sauf si spécialement conçu pour accueillir, ne posez pas d'objets lourds au sommet de ce produit.
5. Placez les articles les plus lourds sur la tablette la plus basse.
6. Ne laissez jamais les enfants grimper ou cogner sur les tiroirs, les portes ou les étagères.

ES Gracias por comprar nuestros productos. Por favor, póngase en contacto con nosotros si tiene dificultades con montaje o necesidad de repuestos.
Nuestro servicio al cliente está aquí para ayudarlo.
Adjunte su nombre de usuario o ID de pedido para que podamos ayudarlo mejor.



ADVERTENCIA

El producto debe ser ensamblado por un adulto antes de su uso.

Se pueden producir lesiones graves o fatales debido al montaje o uso inesperado.

1. Durante el proceso de montaje, mantenga todas las piezas alejadas de bebés o niños.
2. Fije siempre este producto de forma segura a la pared. Asegúrese de que el área de la pared a perforar esté libre de cables eléctricos ocultos, tuberías de agua y gas.
3. El uso de restricciones de vuelco solo puede reducir, pero no elimina el riesgo de que se vuelque.
4. A menos que esté especialmente diseñado para acomodarse, no coloque objetos pesados encima de este producto.
5. Coloque los artículos más pesados en el estante más bajo.
6. Nunca permita que los niños se suban o golpeen los cajones, puertas o estantes.

ZH 感谢您购买我们的产品。如果您有任何困难，请与我们联系。如遇到组装问题或需要更换零件，我们的客服团队会为您提供帮助。
联系时，请附上您的用户名或订单ID，以便我们为您提供更好的帮助。



警告

产品必须由成人组装后才能使用。







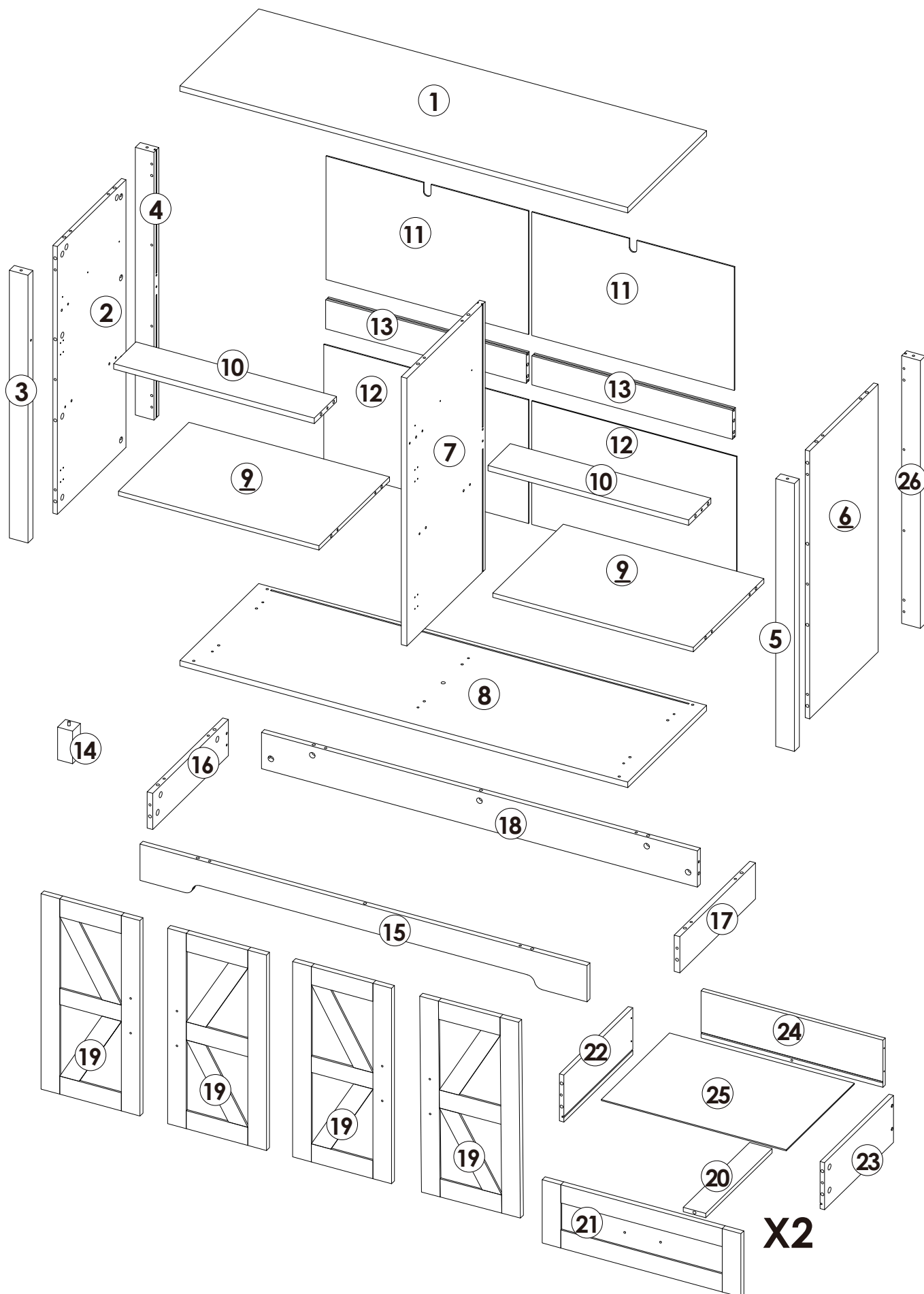



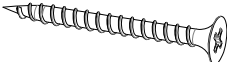

意外组装或使用可能会造成严重或致命的伤害。

1. 在组装过程中，请将所有零件远离婴幼儿。
2. 始终将本产品牢固地固定在墙上。确保钻孔的墙面远离隐蔽的电源线、水和煤气管道。
3. 使用防倾倒装置只能降低倾倒的风险，但不能消除它们。
4. 除非经过特殊设计确保可行，否则请勿在本产品上放置重物。
5. 最重的物品请放在最底层的架子上。
6. 切勿让儿童攀爬或撞击抽屉、门或架子。

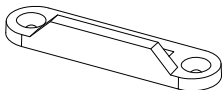
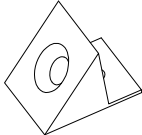
Parts List(EN) / Teile Liste(DE)

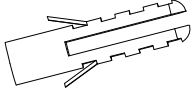
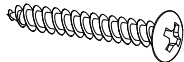

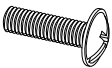
Parts List(EN) / Teile Liste(DE)

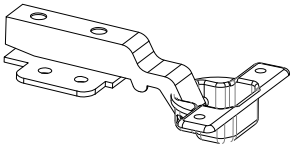
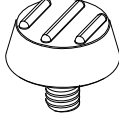
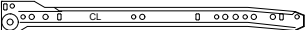
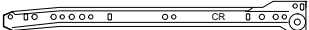
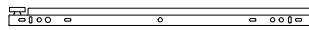
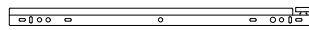
<p>A</p>  <p>M6×32mm 74+2PCS</p>	<p>B</p>  <p>Ø15×9.5mm 74+2PCS</p>	<p>C</p>  <p>Ø6×30mm 54+2PCS</p>	
<p>D</p>  <p>M3.5×12mm 76+2PCS</p>	<p>E</p>  <p>M4×40mm 16+2PCS</p>	<p>F</p>  <p>73×24×15mm 2PCS</p>	
<p>G</p>  <p>M4×12mm 2PCS</p>	<p>H</p>  <p>2PCS</p>	<p>I</p>  <p>16+2PCS</p>	
<p>J</p>  <p>M3×14mm 16+2PCS</p>	<p>K</p>  <p>2PCS</p>	<p>L</p>  <p>M4×32mm 2PCS</p>	
<p>M</p>  <p>6PCS</p>	<p>N</p>  <p>M4×8mm 4PCS</p>	<p>O</p>  <p>M4×18mm 8+1PCS</p>	
<p>P</p>  <p>Ø21mm 26+2PCS</p>	<p>Q</p>  <p>8PCS</p>	<p>R</p>  <p>Ø22mm 1PC</p>	
<p>CL</p>  <p>L350mm 2PCS</p>	<p>CR</p>  <p>L350mm 2PCS</p>	<p>DL</p>  <p>L350mm 2PCS</p>	<p>DR</p>  <p>L350mm 2PCS</p>

Assembly Steps(EN) / Montageschritte(DE)

STEP 1

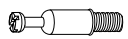
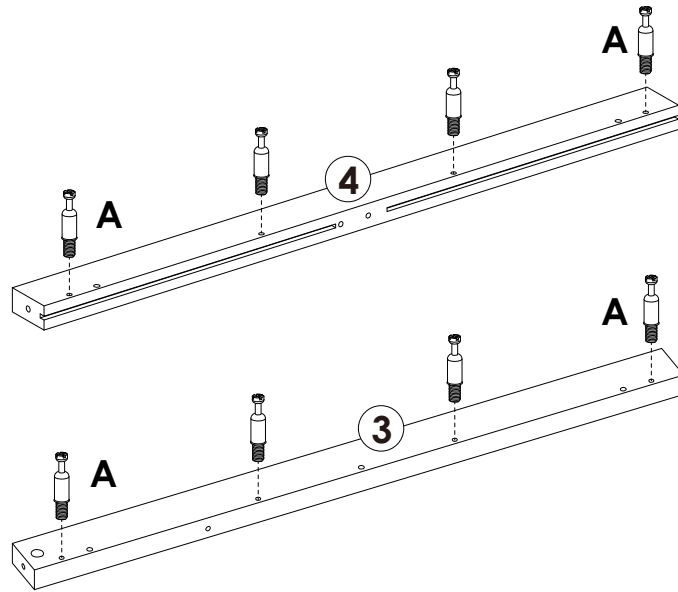

A x 8PCS

STEP 2

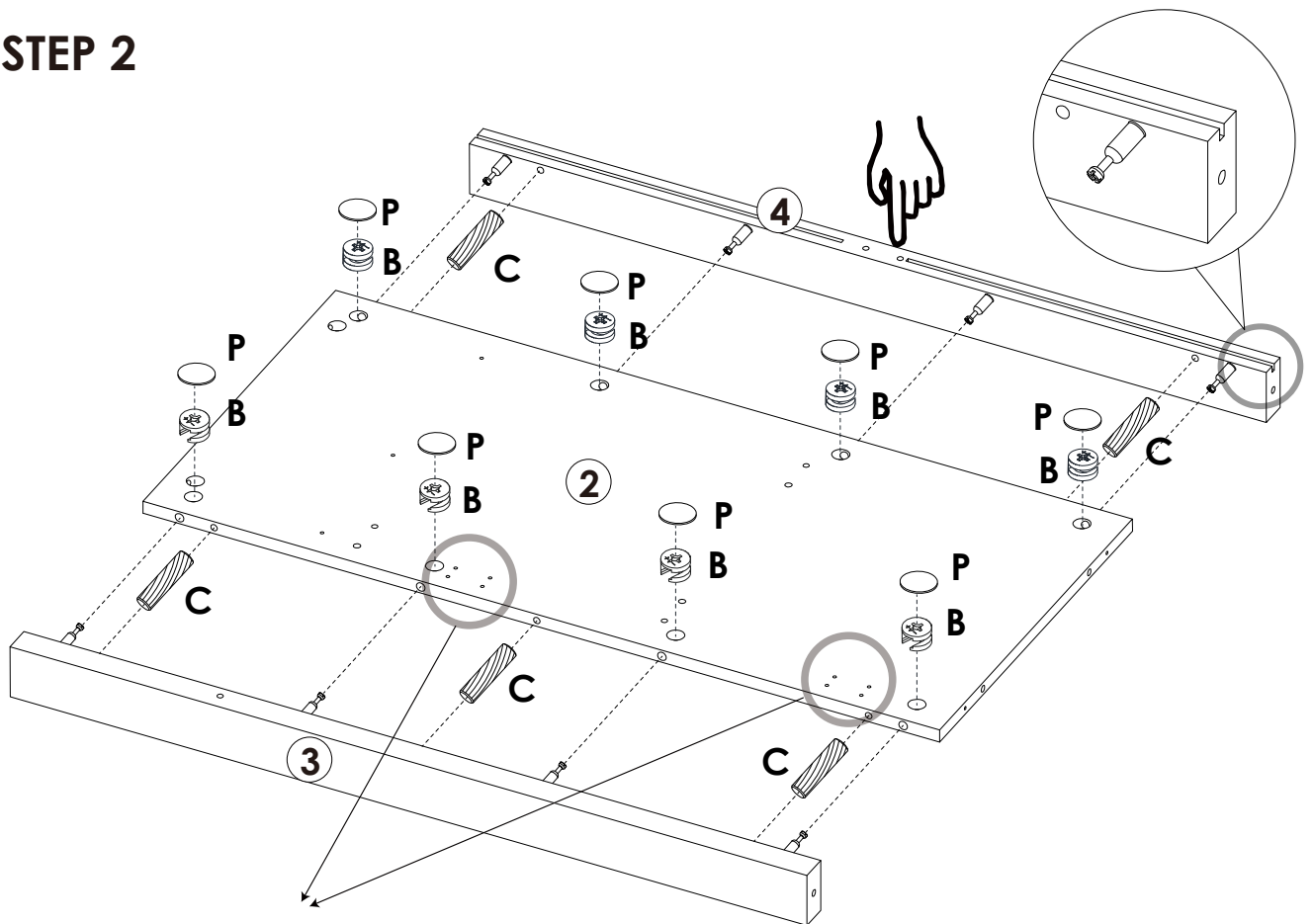

Identify the polarity
to adapt part #3

	B x 8PCS
	C x 5PCS
	P x 8PCS

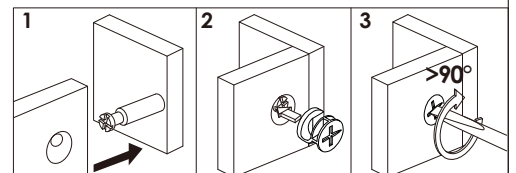

Assembly Steps(EN) / Montageschritte(DE)

STEP 3

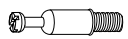
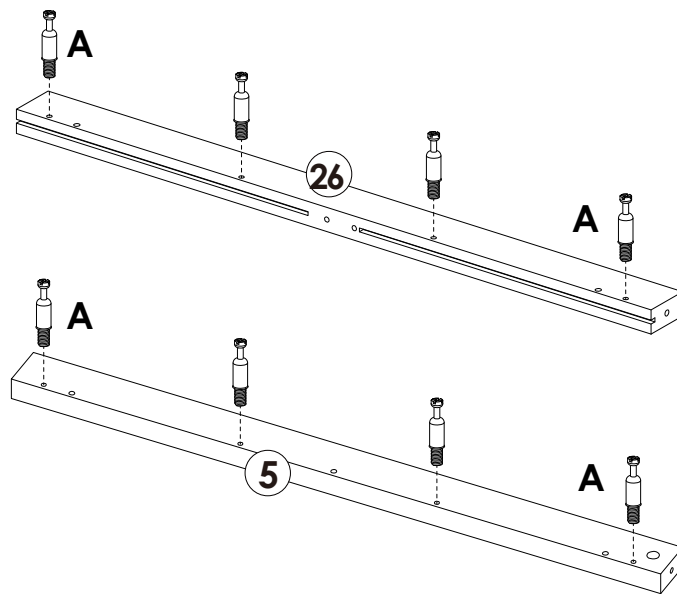

A x 8PCS

STEP 4

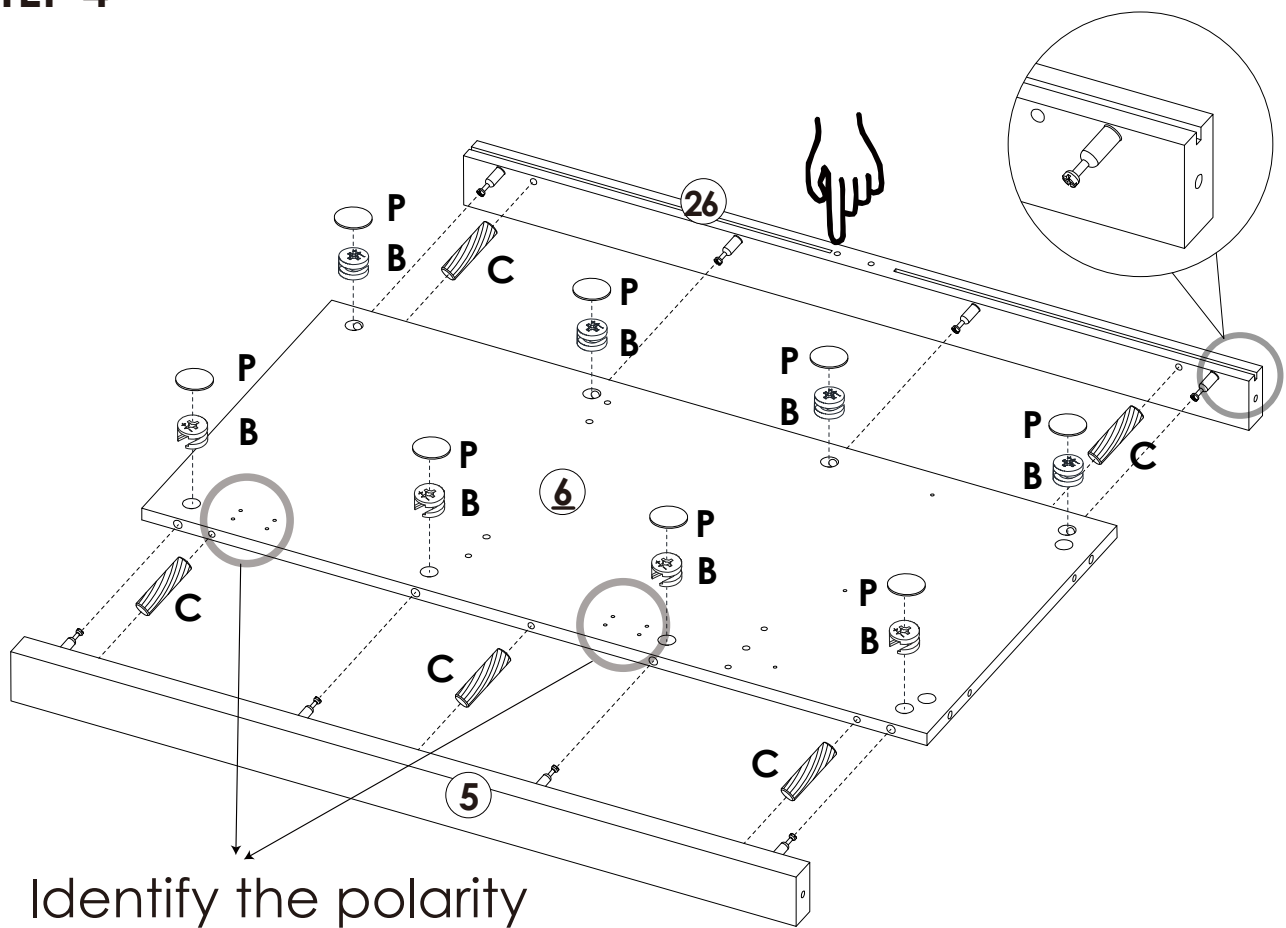

Identify the polarity
to adapt part #5



B x 8PCS



C x 5PCS





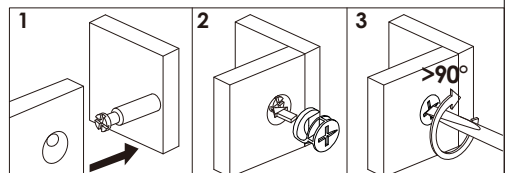

P x 8PCS

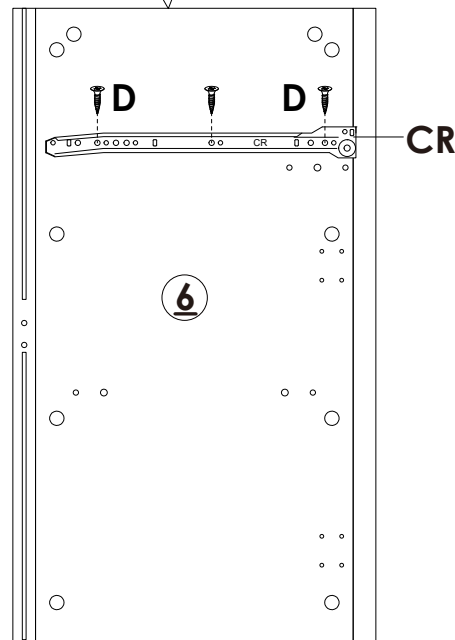
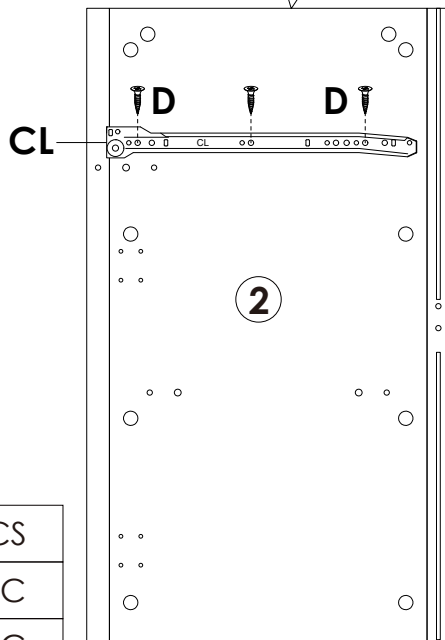
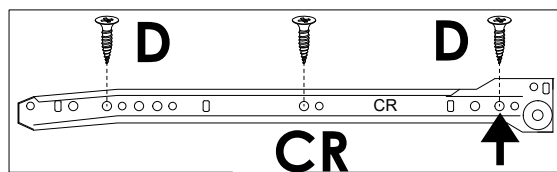
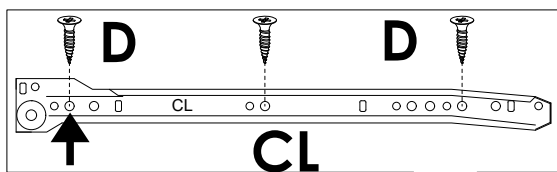

Assembly Steps(EN) / Montageschritte(DE)

STEP 5



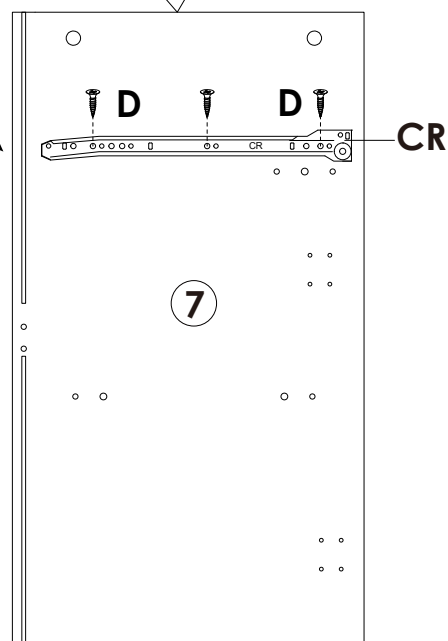
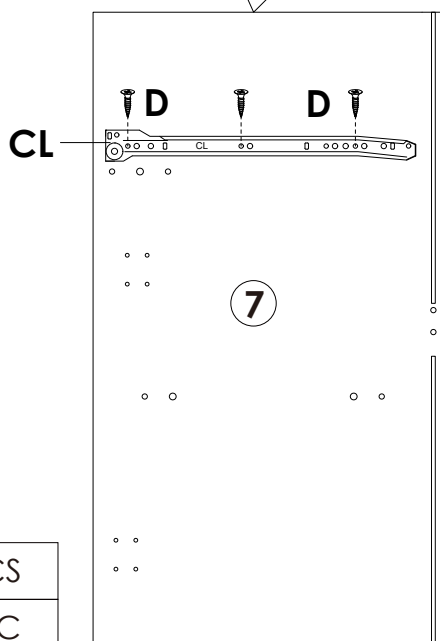
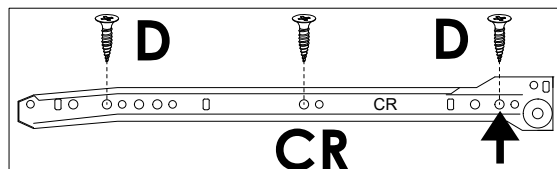
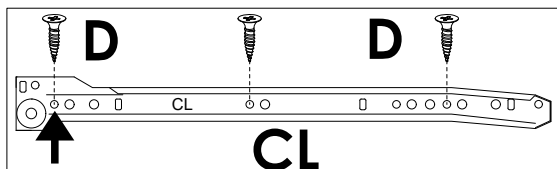

	D x 6PCS
	CL x 1PC
	CR x 1PC

STEP 6



Turn over part ⑦ to install the other side.

	D x 6PCS
	CL x 1PC
	CR x 1PC

Assembly Steps(EN) / Montageschritte(DE)



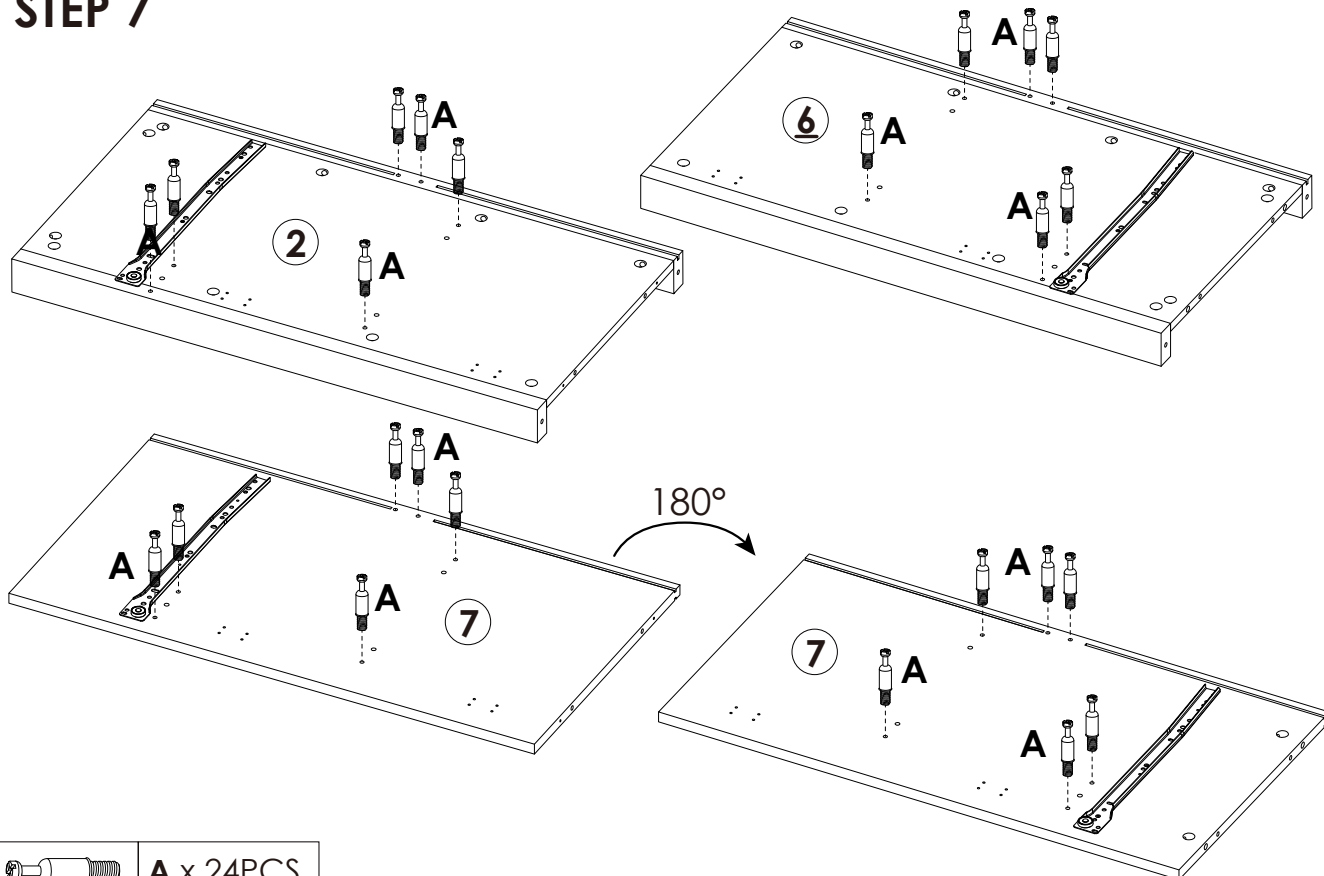

STEP 7

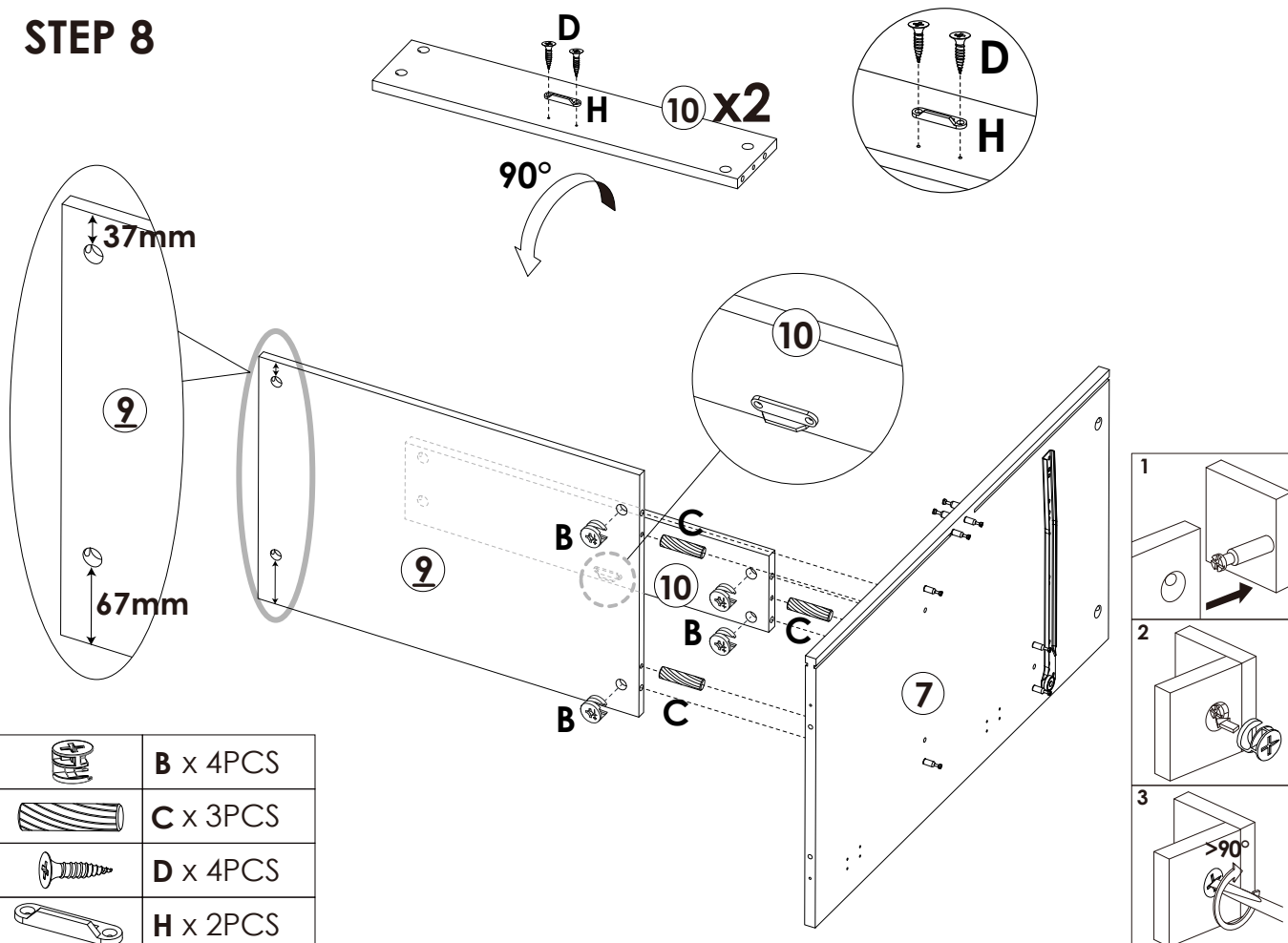

 A x 24PCS

STEP 8



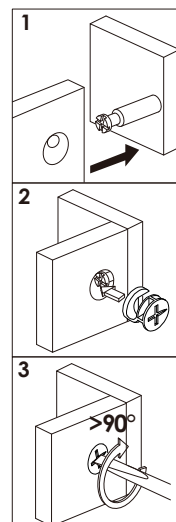

	B x 4PCS
	C x 3PCS
	D x 4PCS
	H x 2PCS



Assembly Steps(EN) / Montageschritte(DE)

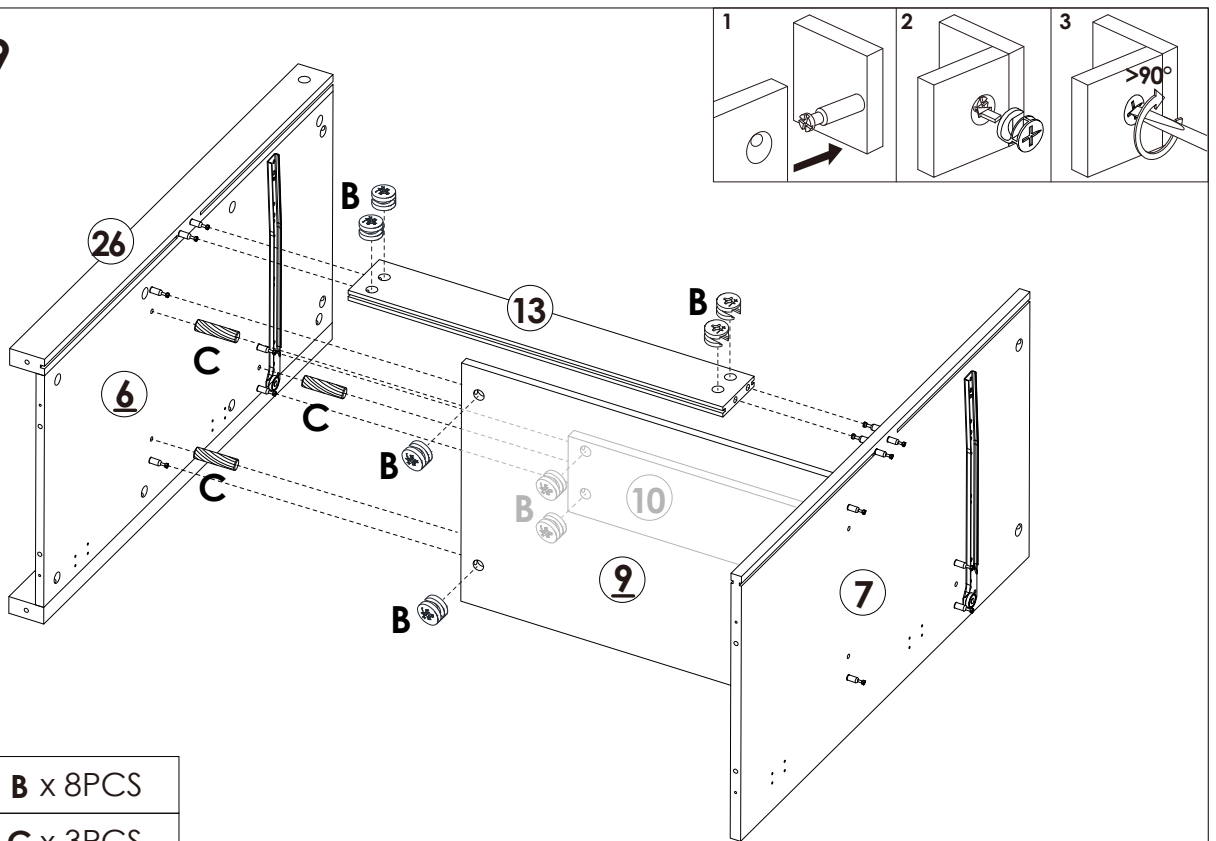

STEP 9

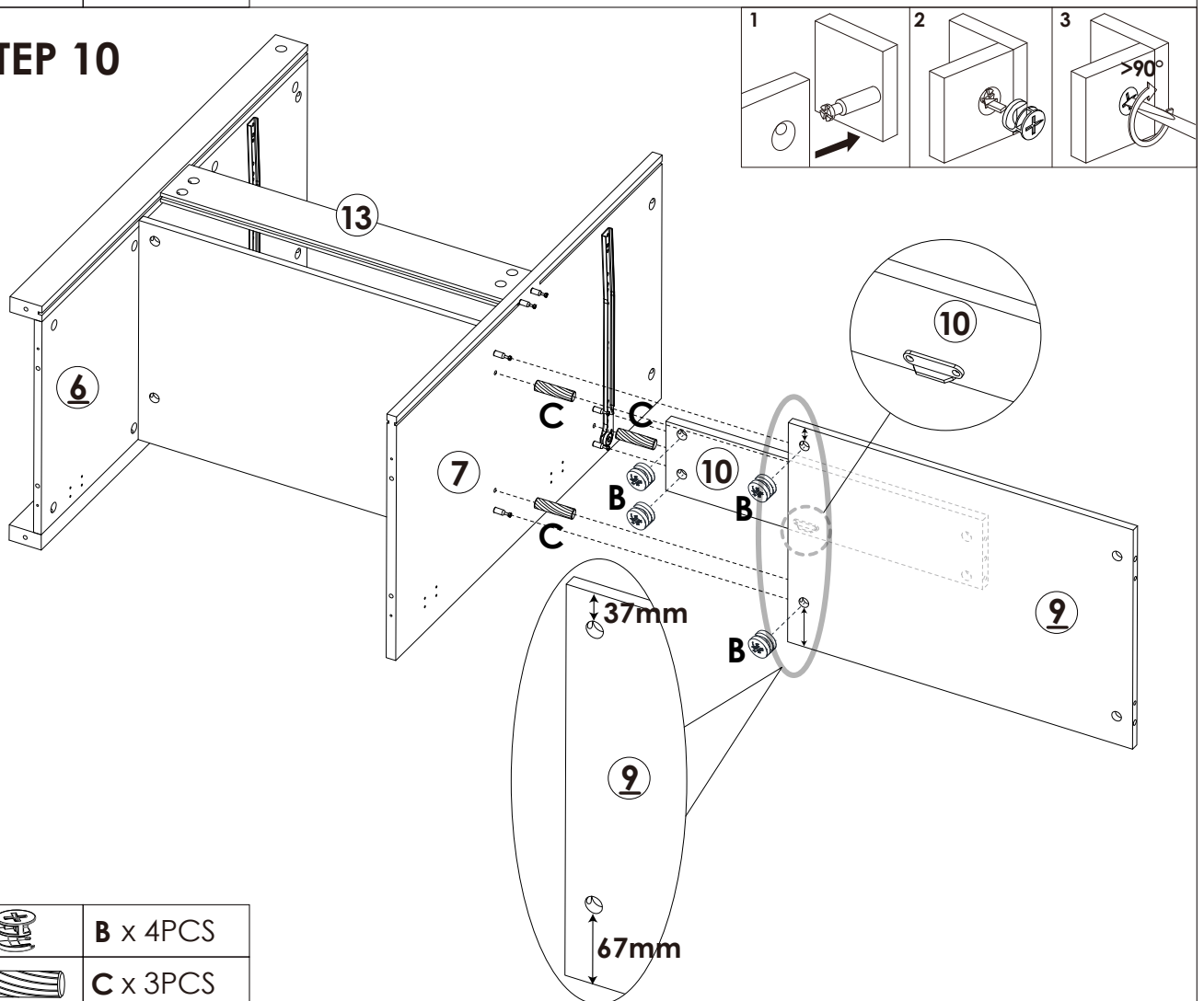

	B x 8PCS
	C x 3PCS

STEP 10





	B x 4PCS
	C x 3PCS

Assembly Steps(EN) / Montageschritte(DE)

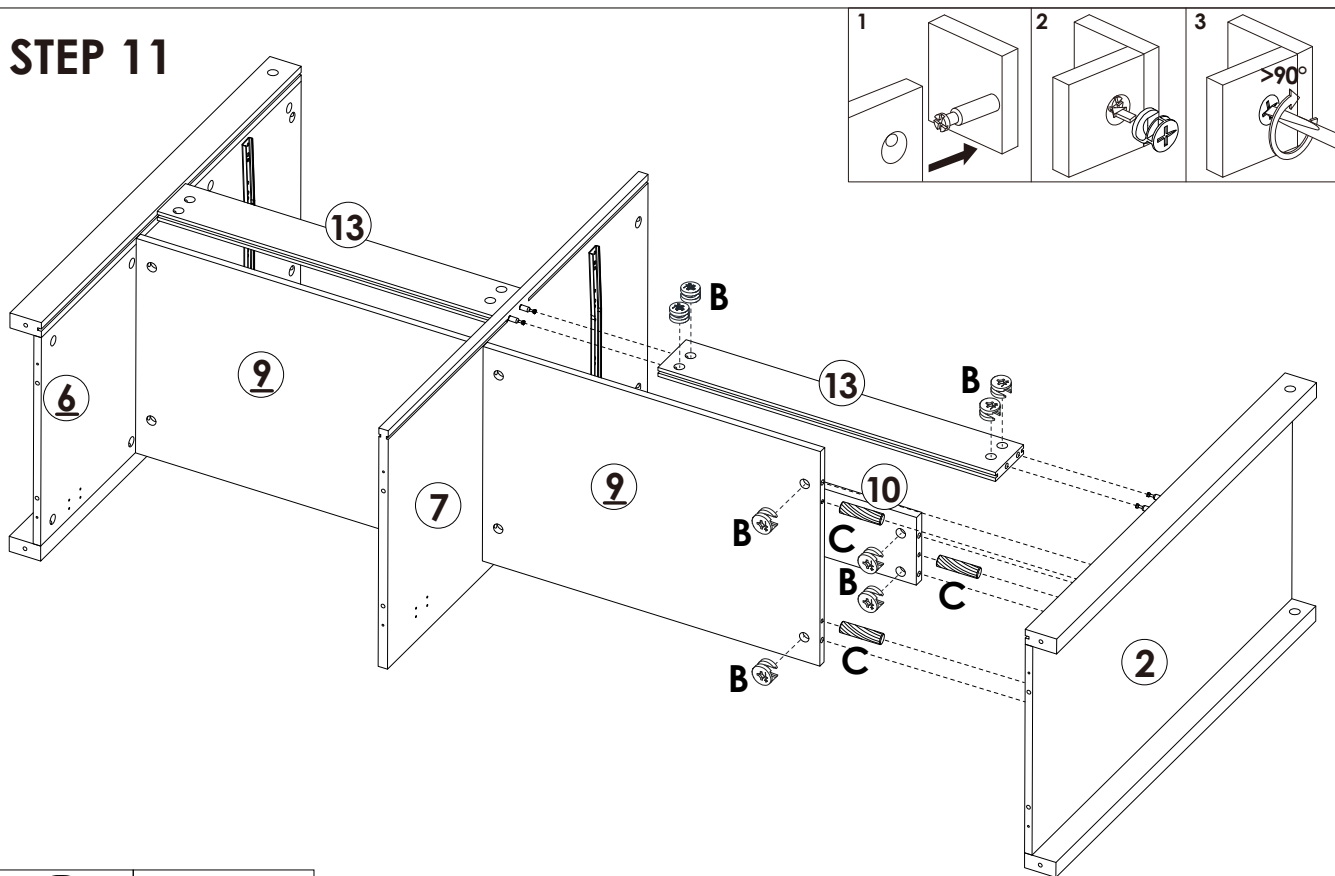
STEP 11



	B x 8PCS
	C x 3PCS

STEP 12

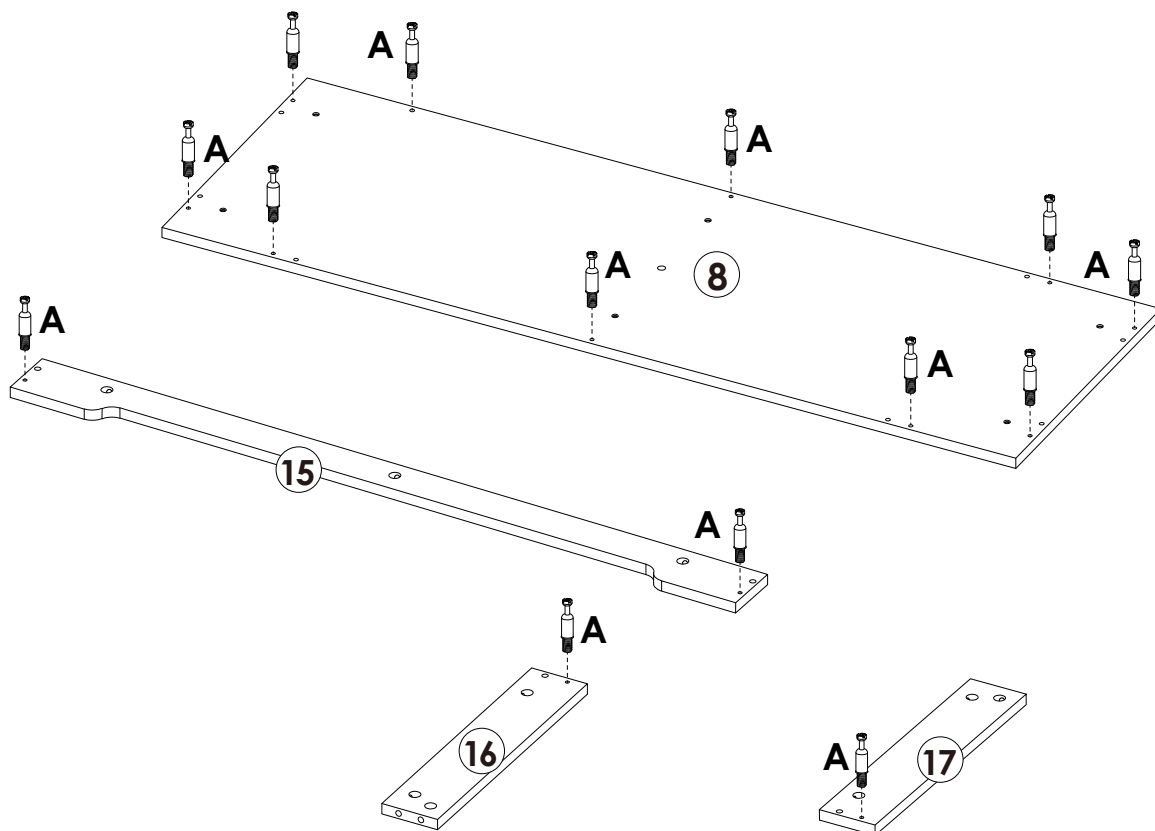



	A x 14PCS
---	------------------

Assembly Steps(EN) / Montageschritte(DE)

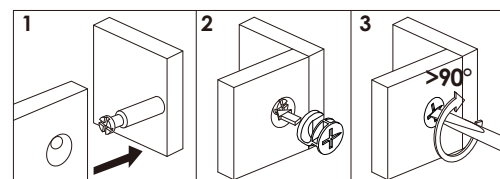
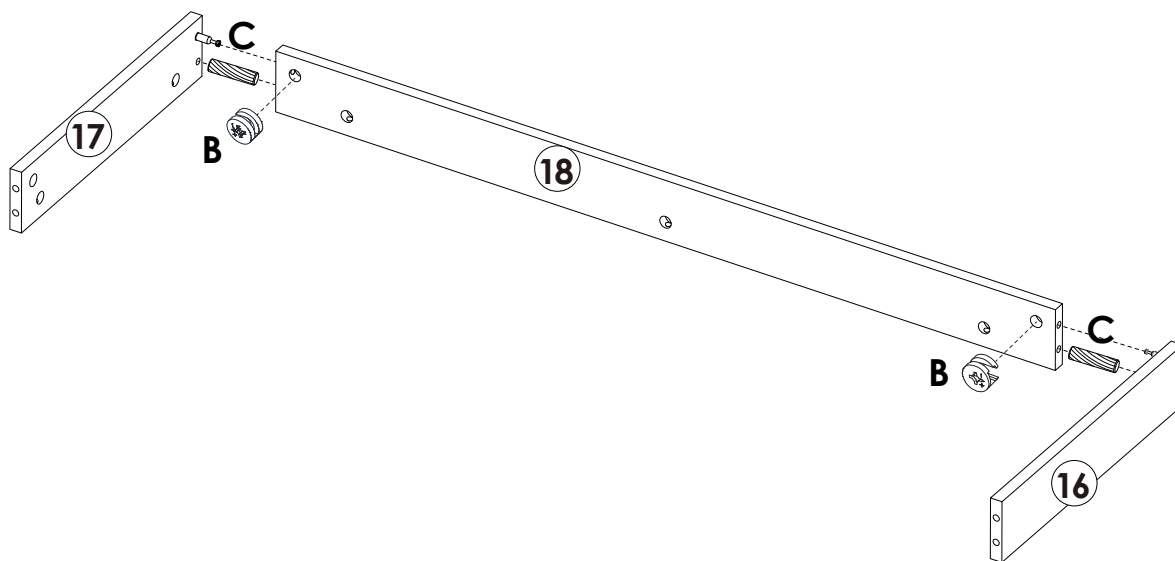

STEP 13

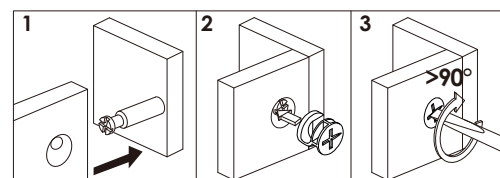
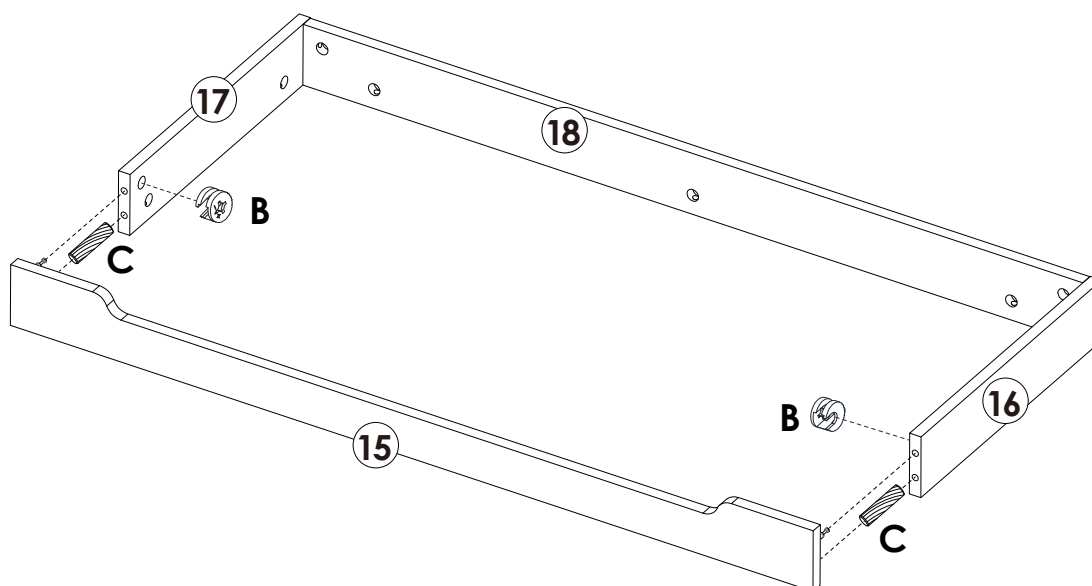

	B x 2PCS
	C x 2PCS

STEP 14





	B x 2PCS
	C x 2PCS

Assembly Steps(EN) / Montageschritte(DE)

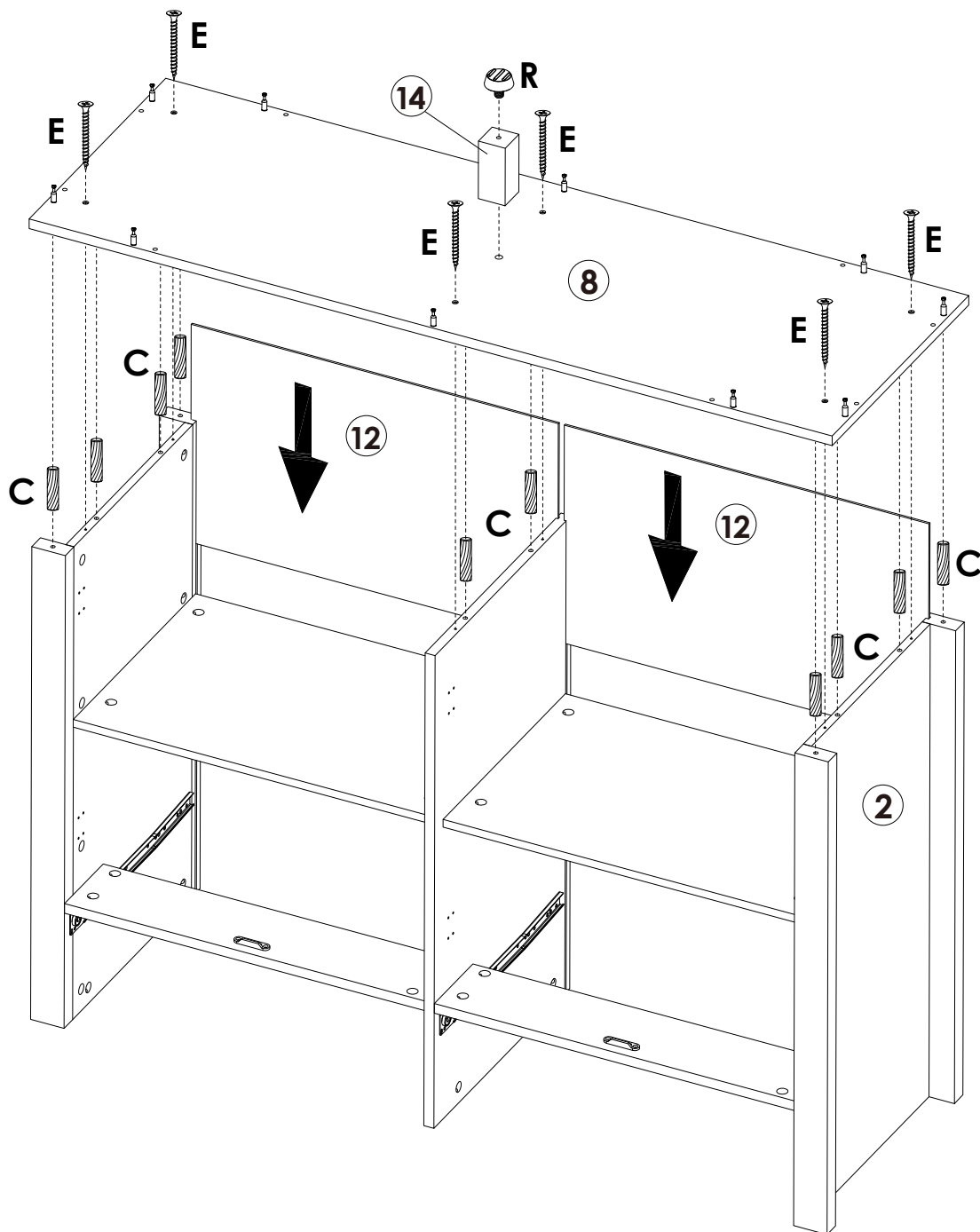
STEP 15

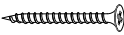



	C x 10PCS
	E x 6PCS
	R x 1PC

Assembly Steps(EN) / Montageschritte(DE)

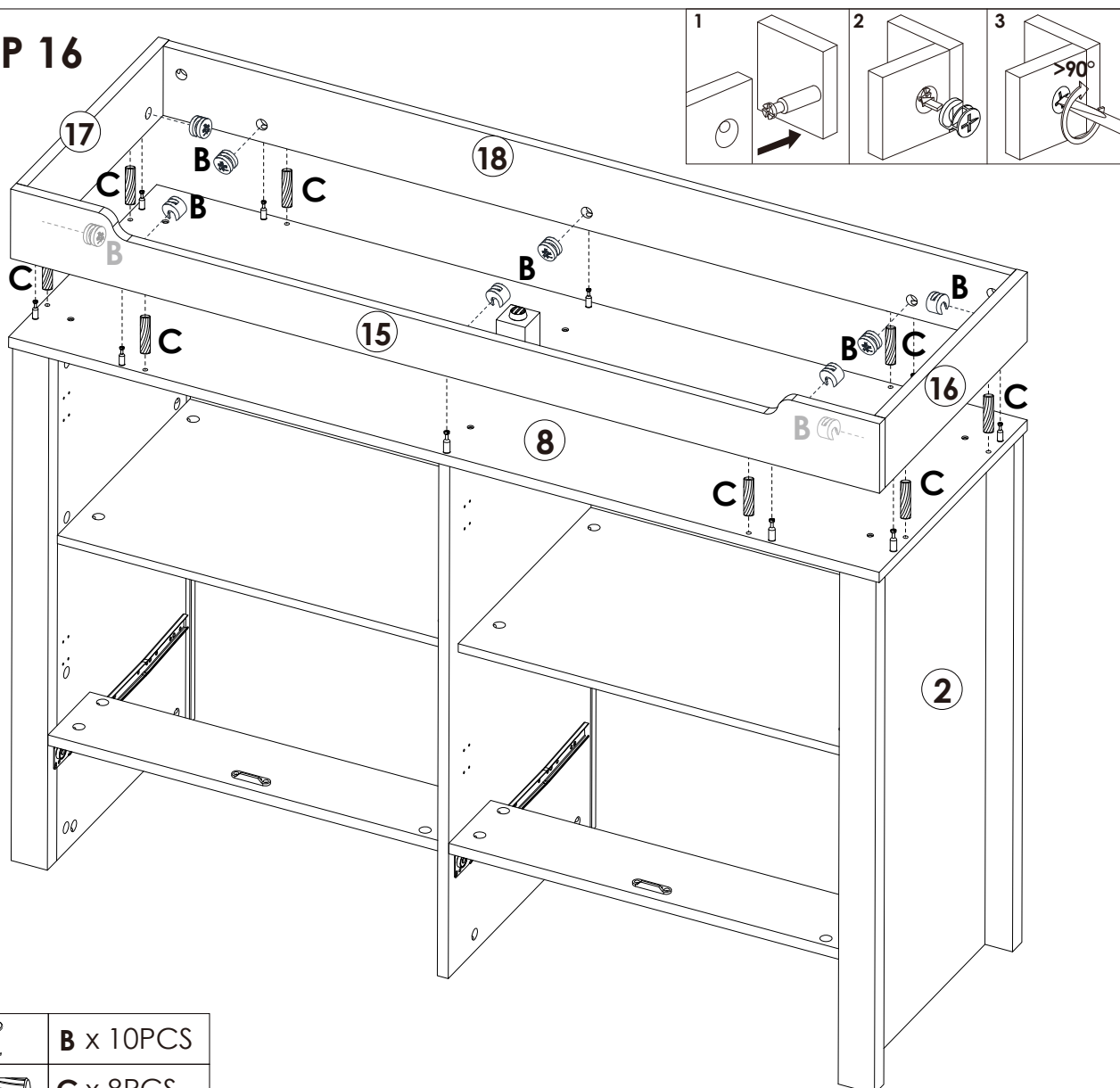
STEP 16





	B x 10PCS
	C x 8PCS

STEP 17

Lock the long side of the "F" L-shaped metal plate to the ① board with the "G" short screw.

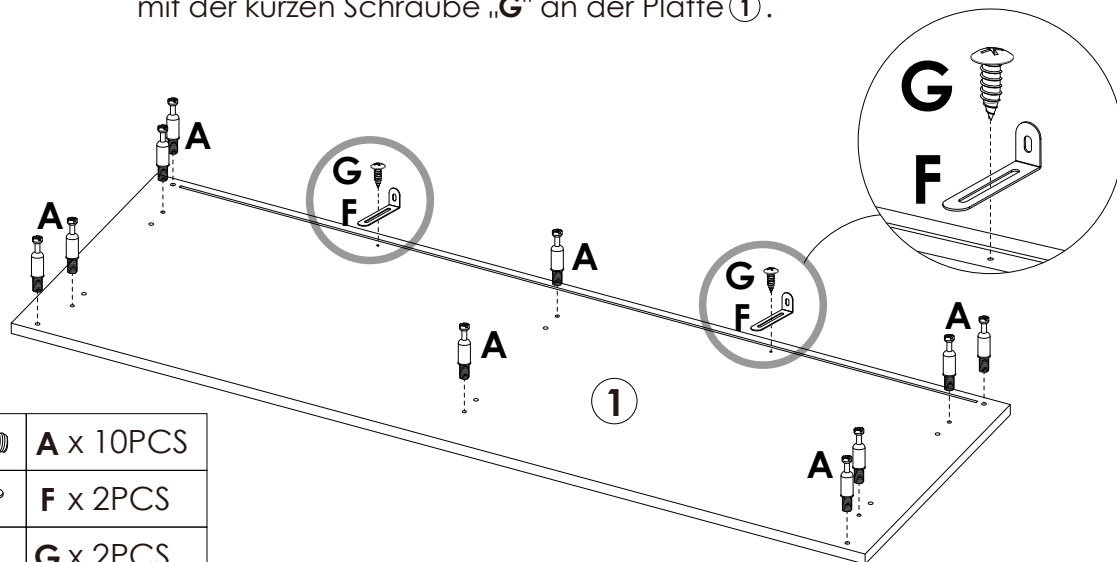

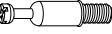
Befestigen Sie die lange Seite der L-förmigen Metallplatte „F“ mit der kurzen Schraube „G“ an der Platte ①.

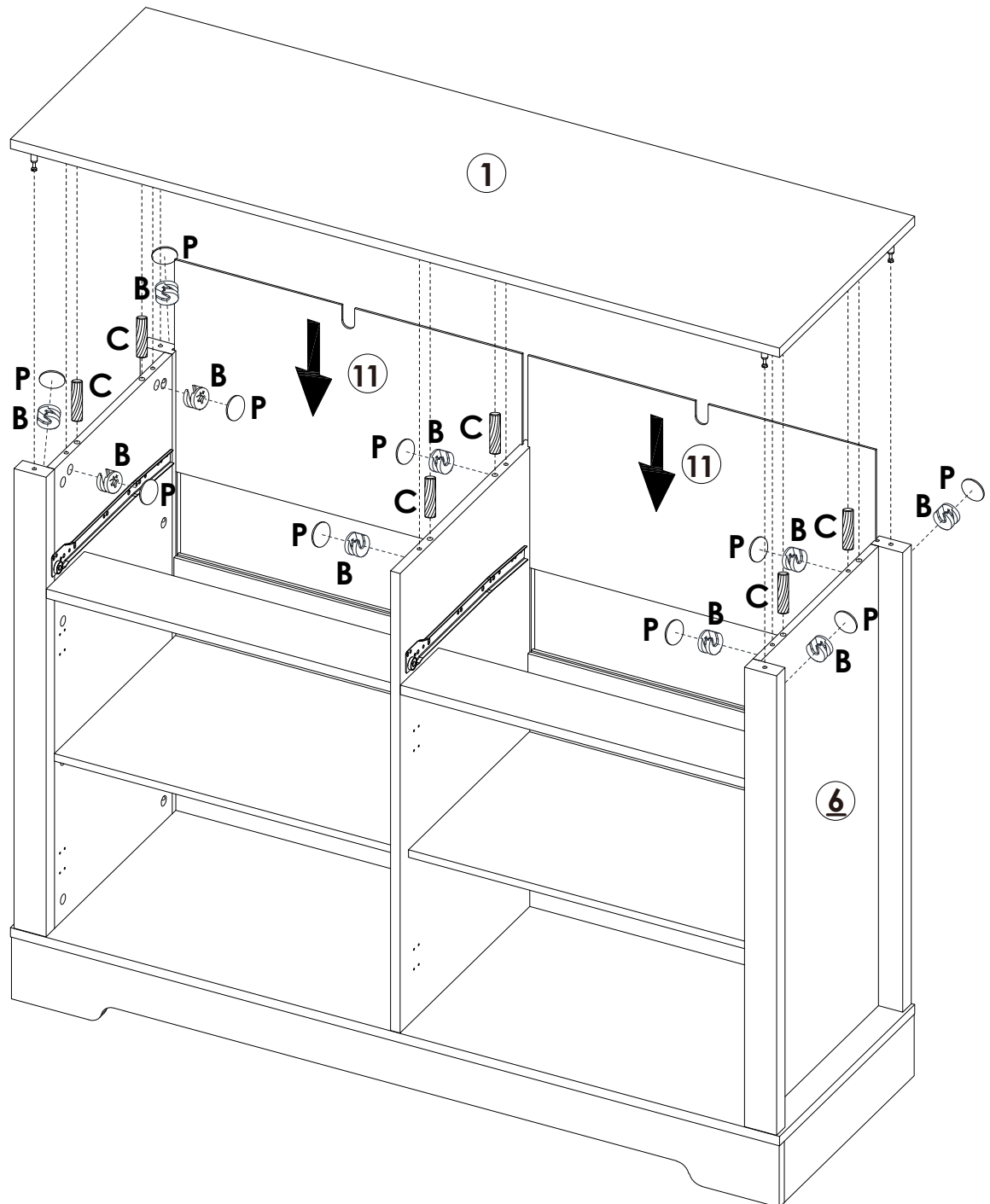

	A x 10PCS
	F x 2PCS
	G x 2PCS

STEP 18



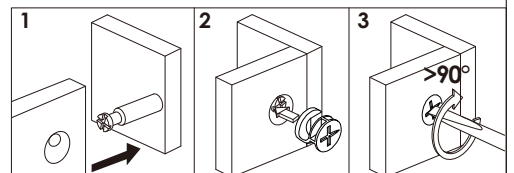

	B x 10PCS
	C x 6PCS
	P x 10PCS

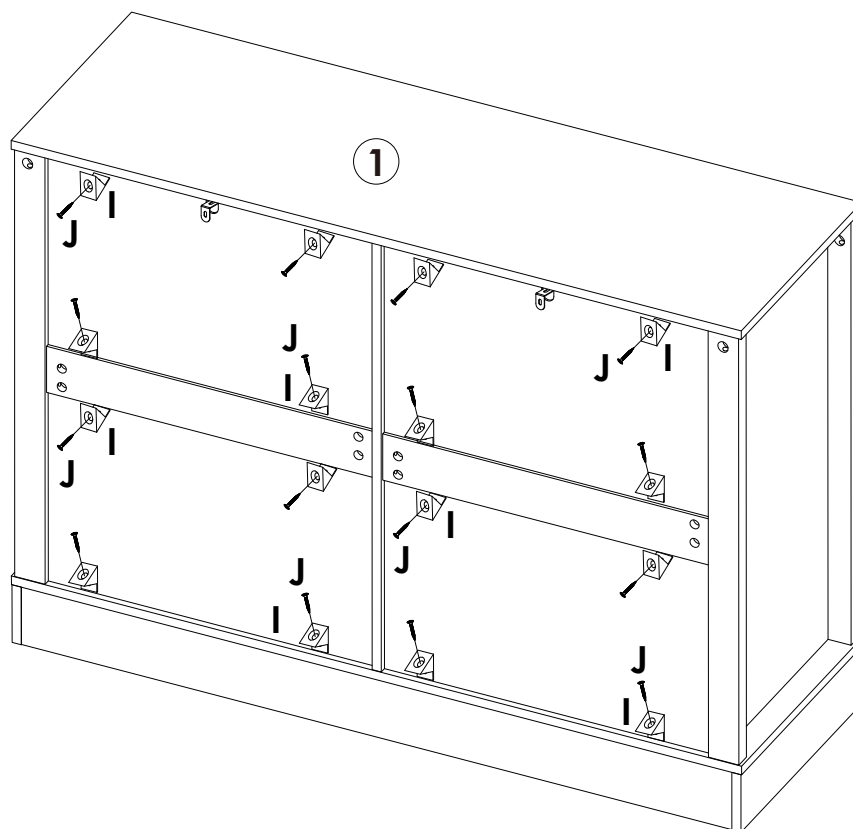
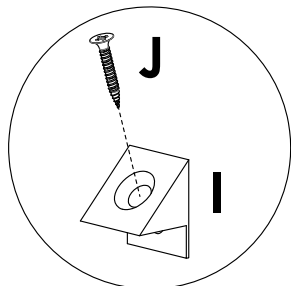

Assembly Steps(EN) / Montageschritte(DE)

STEP 19



	I x 16PCS
	J x 16PCS

STEP 20

Drill 2 holes on the wall at the required position for anti-falling device installation.

Bohren Sie Löcher in die Wand an der gewünschten Stelle für die Installation der Kippsicherung.

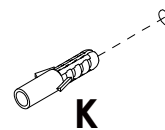
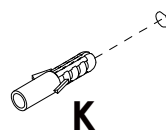
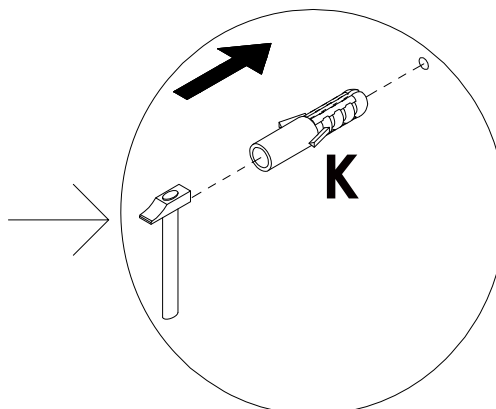
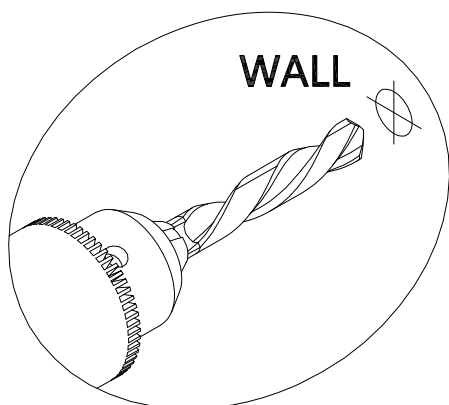

WALL

	K x 2PCS
---	----------

Assembly Steps(EN) / Montageschritte(DE)

STEP 21

Move the cabinet to the required position, use the "L" long screw to fix the cabinet to the wall.

Stellen Sie den Schrank an die gewünschte Position und befestigen Sie den Schrank mit langen Schrauben „E“ an der Wand.

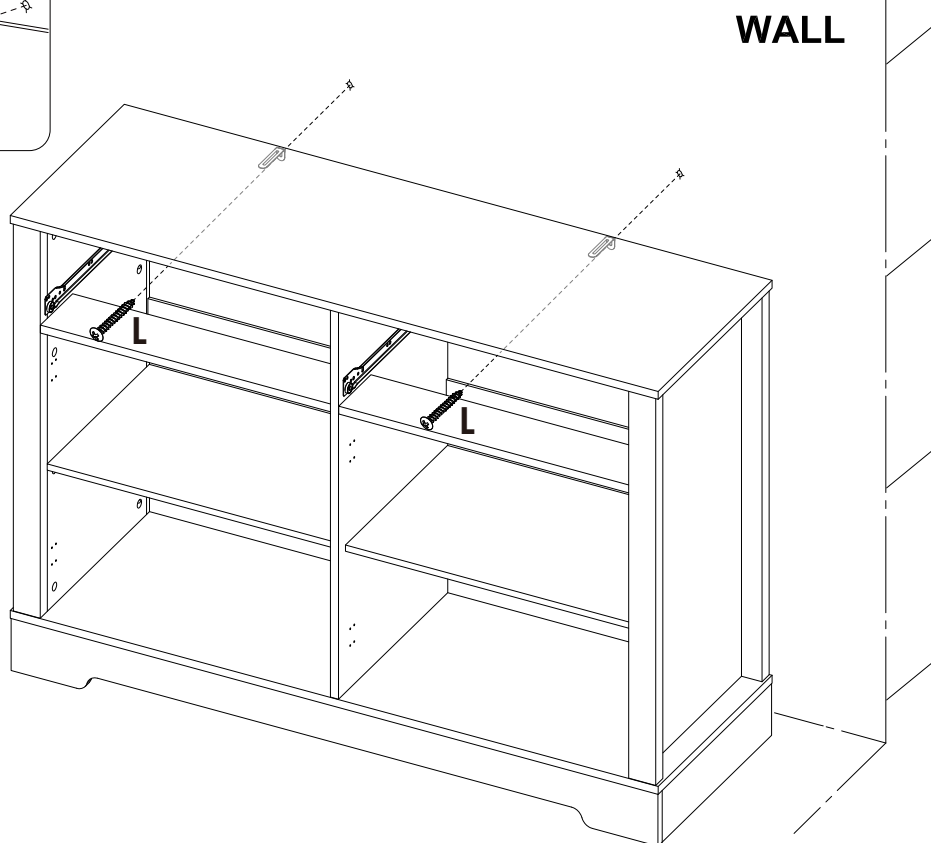
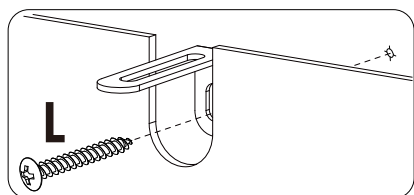

L x 2PCS

STEP 22

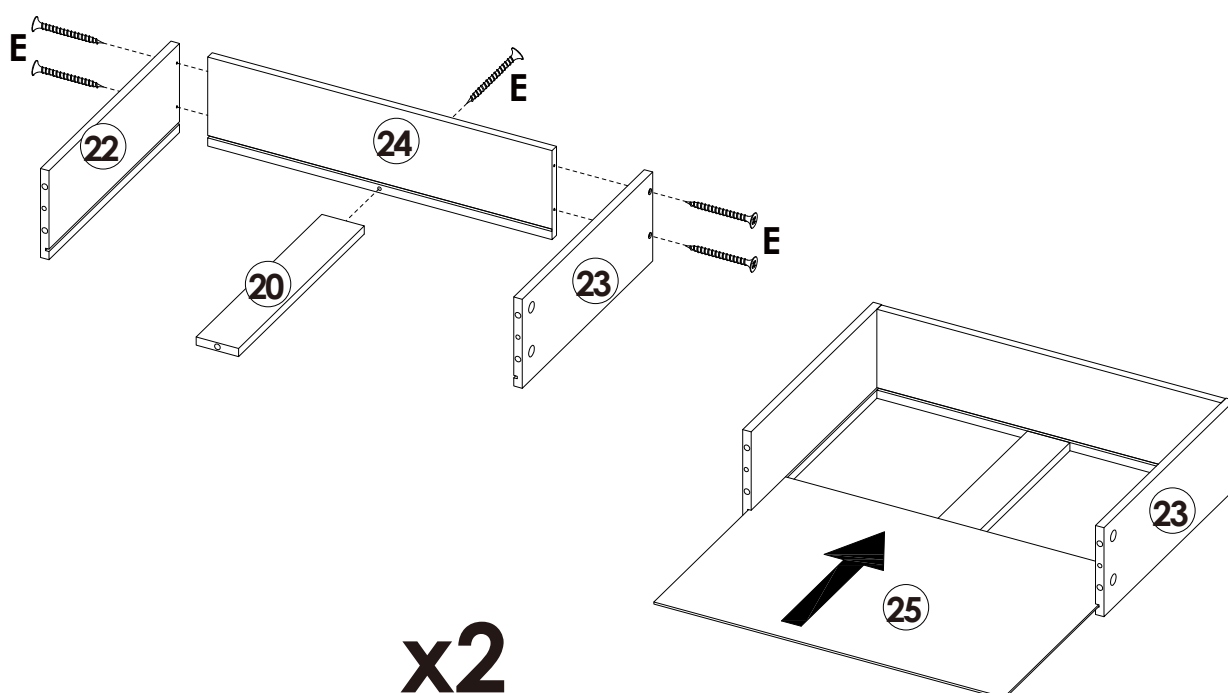

x2





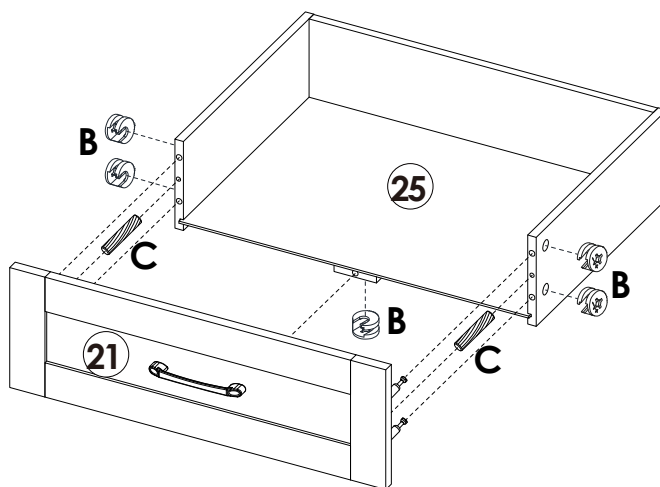
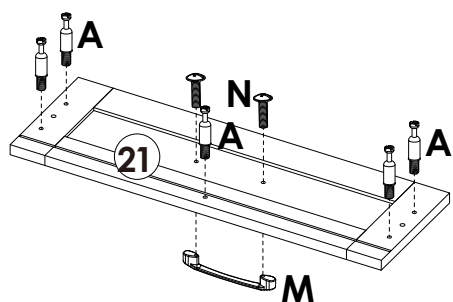

E x 10PCS

Assembly Steps(EN) / Montageschritte(DE)

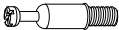
STEP 23





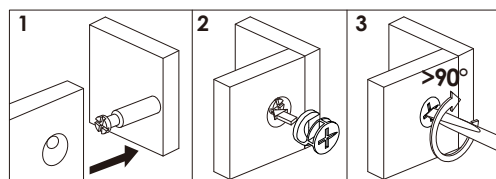

	A x 10PCS
	B x 10PCS
	C x 4PCS
	M x 2PCS
	N x 4PCS

x2

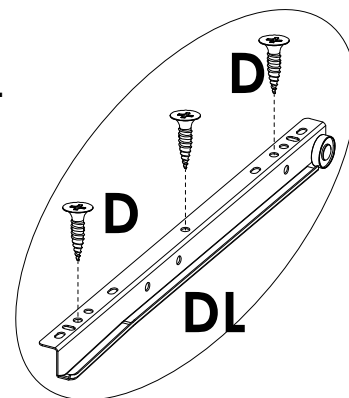
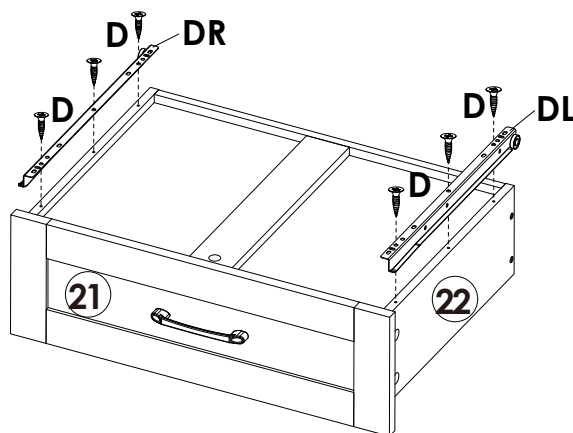
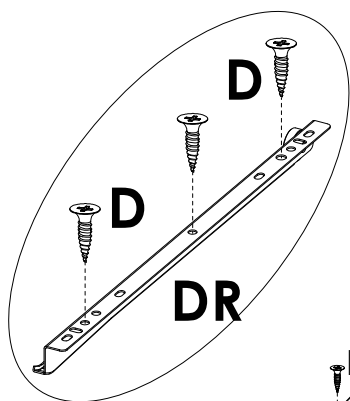

STEP 24

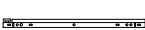

	D x 12PCS
	DL x 2PCS
	DR x 2PCS

x2

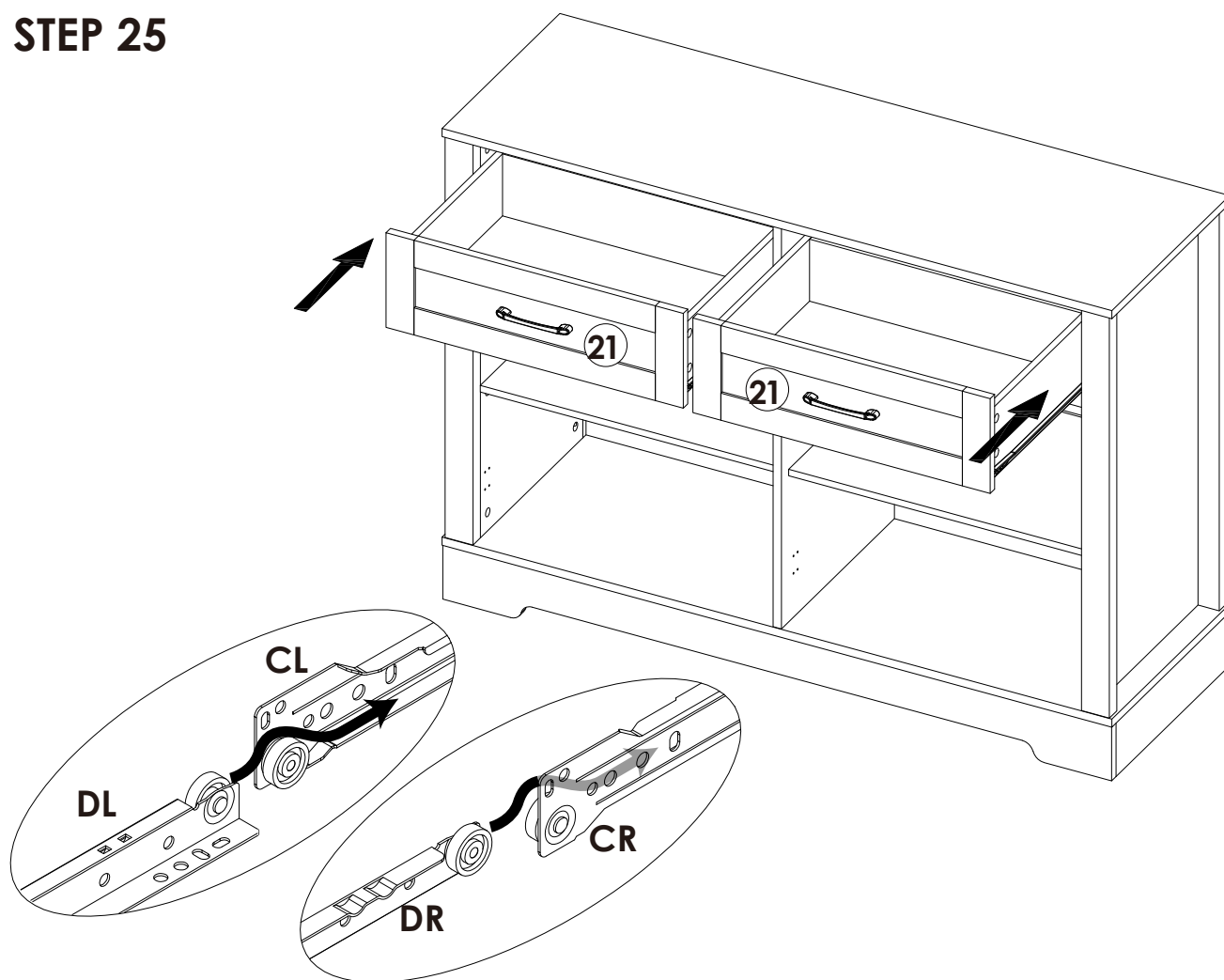

Assembly Steps(EN) / Montageschritte(DE)

STEP 25

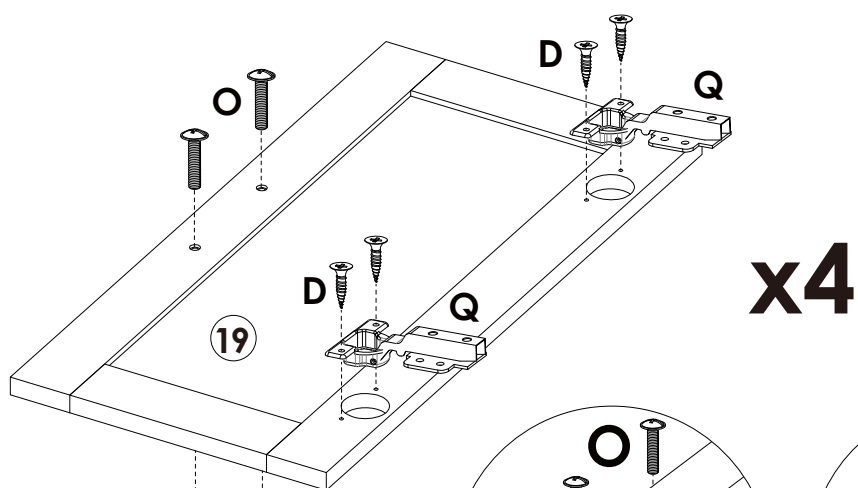

STEP 26

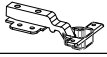

	D x 16PCS
	Q x 8PCS
	M x 4PCS
	O x 8PCS

Assembly Steps(EN) / Montageschritte(DE)

STEP 27

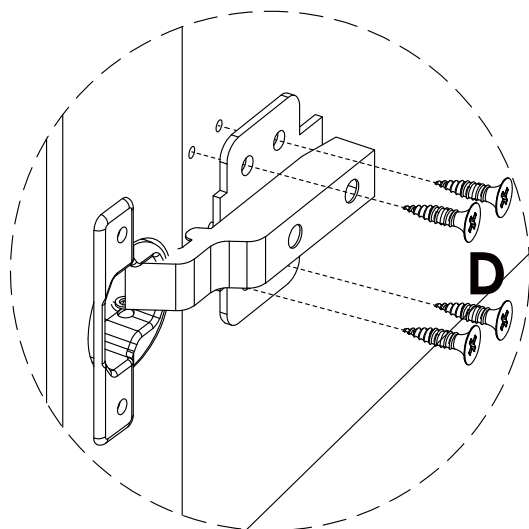
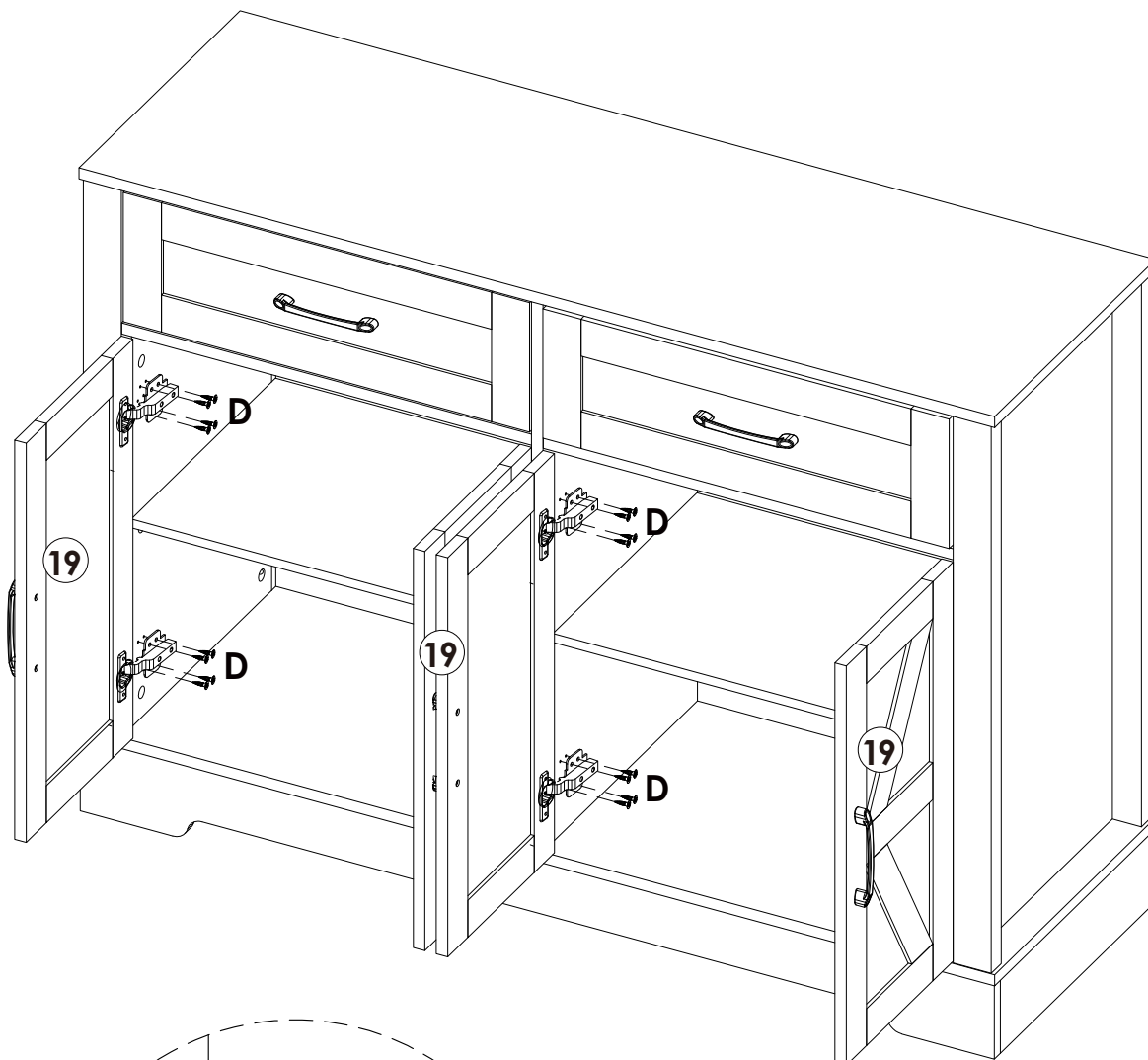

D x 32PCS

EN: When the hinges are installed, you can refer to the pictures to adjust gap of the doors till it's perfect:

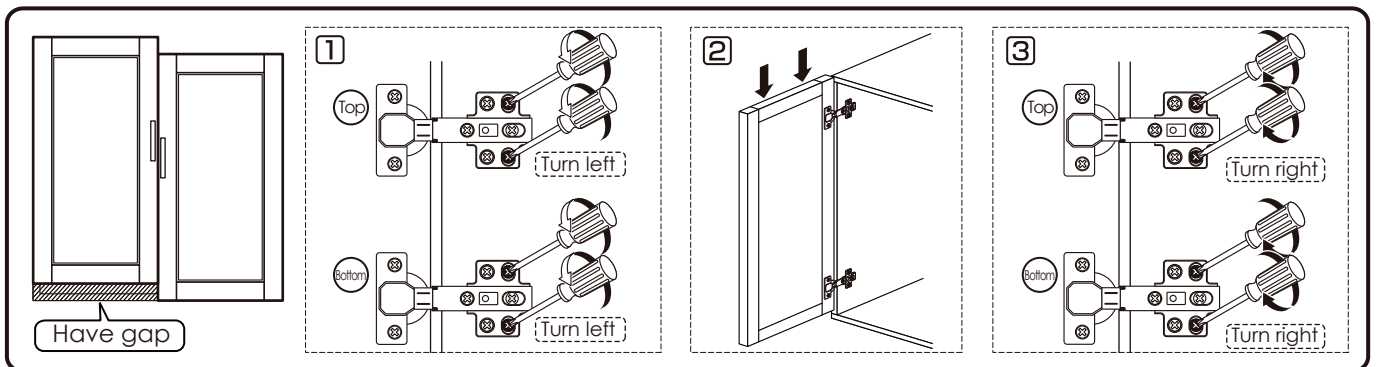
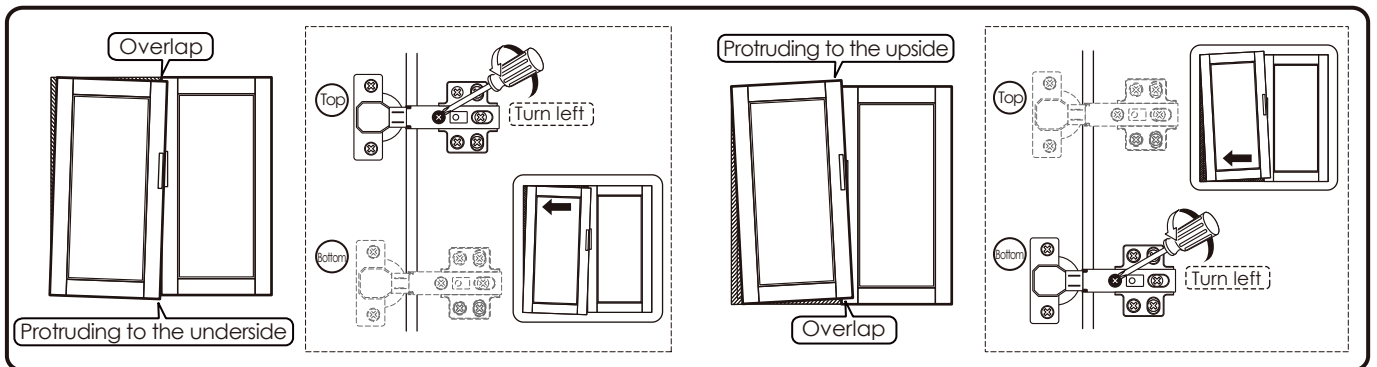
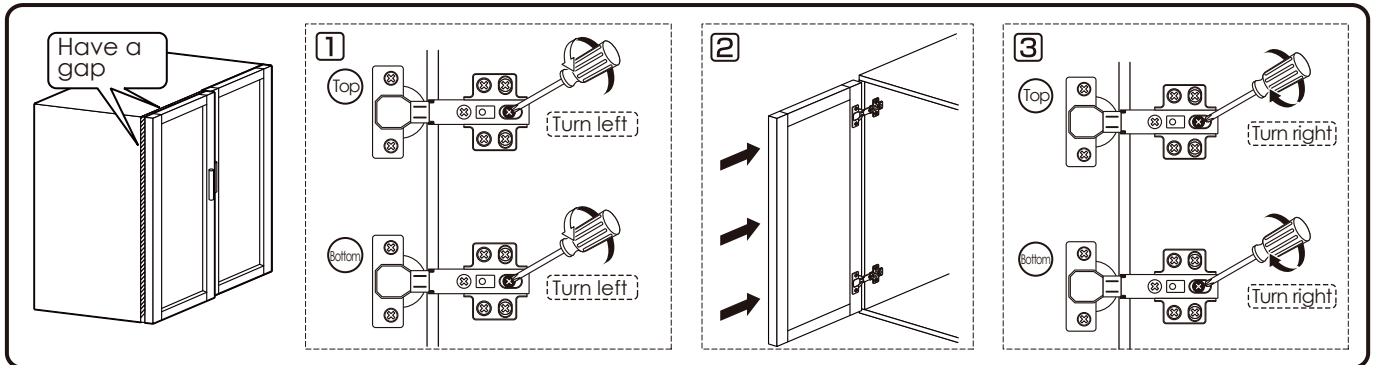
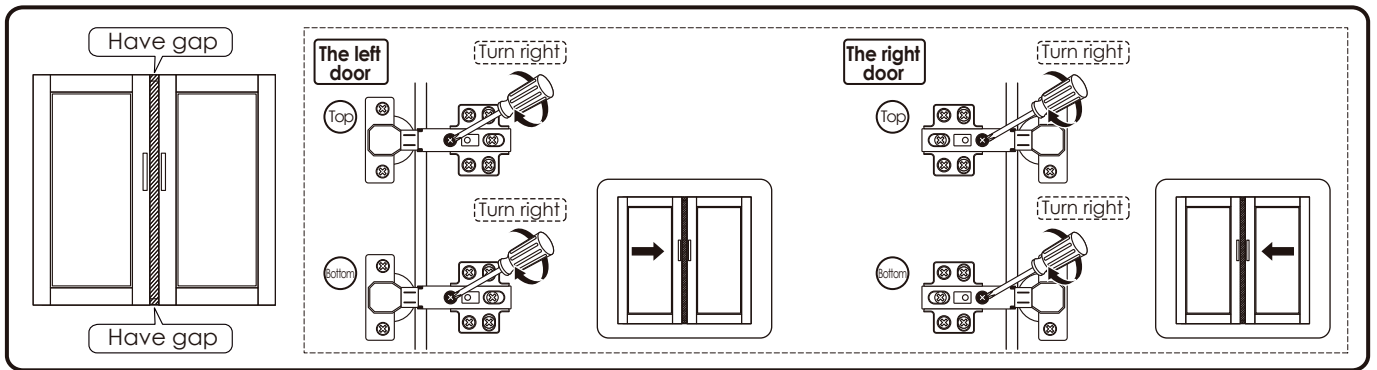

DE: Nach der Montage der Scharniere können Sie den Abstand zwischen den Türen anhand der Bilder einstellen, bis er perfekt ist:

ES: Cuando las bisagras estén instaladas, puedes consultar las imágenes para ajustar el espacio de la puerta hasta que quede perfecto:

IT: Una volta installate le cerniere, è possibile fare riferimento alle immagini per regolare la fessura della porta fino a ottenere il risultato perfetto:

FR: Après avoir installé les charnières, vous pouvez ajuster l'espace de la porte selon l'image jusqu'à ce qu'il soit parfait:

ZH: 铰链安装好后，可以参照图片调整门的间隙，直到完美：

WARNING



Children have died from furniture tipover. To reduce the risk of furniture tipover:

- **ALWAYS** install Anti-tip device provided.
- For use with televisions weighing 30 lb or less. Use with heavier televisions may result in instability causing tip-over resulting in death or serious injury.
- **NEVER** allow children to stand, climb or hang on any drawers, doors, or shelves.
- **NEVER** open more than one drawer at a time.
- Place heaviest items in the lowest drawers.

***This is a permanent label.
Do not remove!***

WARNUNG



Kinder sind durch umgefallene Möbel gestorben. Um das Risiko des Umkippens von Möbeln zu verringern:

- Installieren Sie immer die mitgelieferte Kippsicherung.
- Zur Verwendung auf Fernsehgeräten mit einem Gewicht von 30 Pfund oder weniger. Die Verwendung mit schwereren Fernsehgeräten kann zu Instabilität und Umkippen führen, was zum Tod oder zu schweren Verletzungen führen kann.
- Erlauben Sie Kindern niemals, an Schubladen, Türen oder Regalen zu stehen, daran zu klettern oder daran zu hängen.
- Öffnen Sie niemals mehr als eine Schublade gleichzeitig.
- Platzieren Sie Ihre schwersten Gegenstände in die unterste Schublade oder das unterste Regal.

***Dies ist ein dauerhaftes Etikett.
Bitte nicht entfernen!***



AVERTISSEMENT



Des enfants sont morts à cause du renversement de meubles. Pour réduire le risque de renversement des meubles :

- Assurez-vous d'installer le dispositif anti-basculement fourni.
- À utiliser sur des téléviseurs pesant 30 livres ou moins. L'utilisation des téléviseurs plus lourds peut entraîner une instabilité, entraînant un basculement et des blessures graves ou mortelles.
- Ne laissez jamais les enfants se lever, grimper ou se suspendre aux tiroirs, aux portes ou aux étagères.
- N'ouvrez jamais plus d'un tiroir à la fois.
- Placez vos objets les plus lourds dans le tiroir ou l'étagère du bas.

***Il s'agit d'une étiquette permanente.
Ne l'enlevez pas!***



AVVERTIMENTO



I bambini sono morti per il ribaltamento dei mobili. Per ridurre il rischio di ribaltamento dei mobili:

- Installare SEMPRE il dispositivo antiribaltamento fornito.
- Da utilizzare su televisori di peso pari o inferiore a 30 libbre. L'uso con televisori più pesanti può causare instabilità, causando il ribaltamento, con conseguenti morte o lesioni gravi.
- Non permettere MAI ai bambini di stare in piedi, arrampicarsi o appendersi a cassetti, porte o scaffali.
- Non aprire MAI più di un cassetto alla volta.
- Metti gli oggetti più pesanti nei cassetti o negli scaffali più bassi.

***Questa è un'etichetta permanente.
Non rimuovere!***



ADVERTENCIA



Han muerto niños por el vuelco de muebles. Para reducir el riesgo de que los muebles se vuelquen:

- SIEMPRE Instale el dispositivo antivuelco proporcionado.
- Para uso en televisores que pesan 30 libras o menos. El uso con televisores más pesados puede causar inestabilidad, provocar vuelcos y provocar la muerte o lesiones graves.
- NUNCA permita que los niños se paren, trepen o cuelguen de ningún cajón, puerta o estante.
- NUNCA abra más de un cajón a la vez.
- Coloque sus artículos más pesados en el cajón más bajo.

Esta es una etiqueta permanente. No quitar!



警告



儿童曾死于家具翻倒。

为了降低家具倾倒的风险：

- 请始终安装所提供的防倾倒装置。
- 适用于重量为30磅或以下的电视机。用于更重的电视机可能会导致不稳定，引起翻倒，造成死亡或严重伤害。
- 切勿让儿童站立、攀爬或悬挂在任意抽屉、门或架子上。
- 切勿同时打开一个以上的抽屉。
- 将最重的物品放在最低的抽屉里。

**这是永久性标签。
请勿移除！**