

# Assembly Instruction

## ASSEMBLY TIPS:





1. Remove hardware from box and sort by size.
2. Please check to see that all hardware and parts are present prior to start of assembly.
3. Please follow attached instructions in the same sequence as numbered to assure fast & easy assembly.





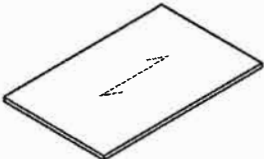
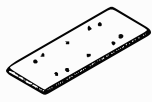

## Warning !

1. Don't attempt to repair or modify parts that are broken or defective. Please contact the store immediately.
2. This product is for home use only and not intended for commercial establishment.

## PARTS IDENTIFICATION:

- A . TABLE TOP  1 PC
- B . PEDESTAL TOP BOARD  1 PC
- C . LARGE SIDE PANEL  2 PCS
- D . SMALL SIDE PANEL  2 PCS
- E . BASE  1 PC

## Z HARDWARE PACKAGE:

NO	DESCRIPTION	FIGURE	QTY
1	BOLT		26 PCS
2	LOCK WASHER		26 PCS
3	FLAT WASHER		26 PCS
4	WOODEN DOWEL		20 PCS
5	ALLEN WRENCH		1 PC

**STEP 1**

Compose the **LARGE SIDE PANEL** and **SMALL SIDE PANEL**. Place the **WOODEN DOWEL** for initial firm-up then use **FLAT WASHER, LOCK WASHER** and **BOLT** to fix and fasten tight by **ALLEN WRENCH**.

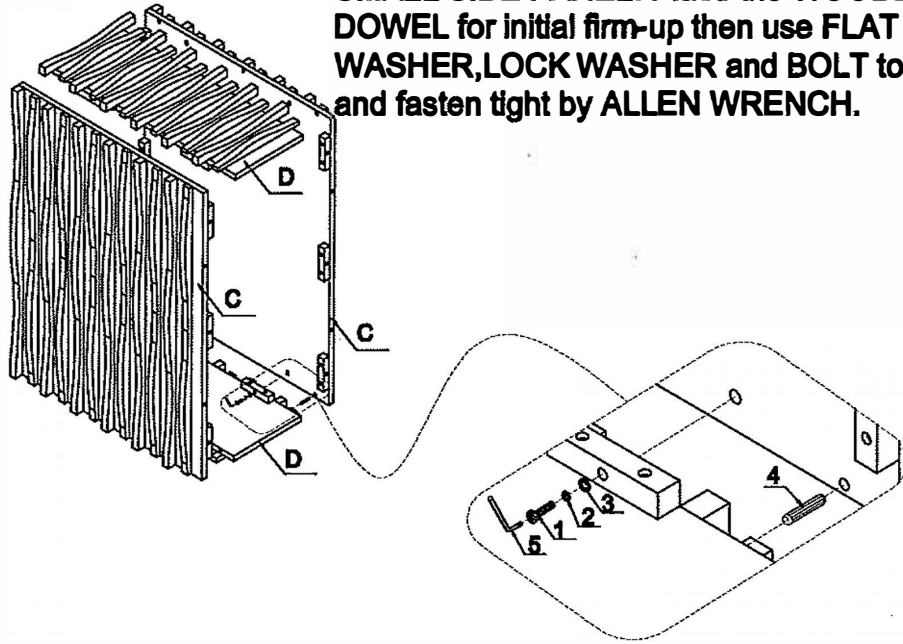

**STEP 2**

Insert the **WOODEN DOWEL** and Put on the **PEDESTAL TOP** on the **PEDESTAL**. Use **FLAT WASHER** and **LOCK WASHER** to fix and fasten **BOLT** by **ALLEN WRENCH**

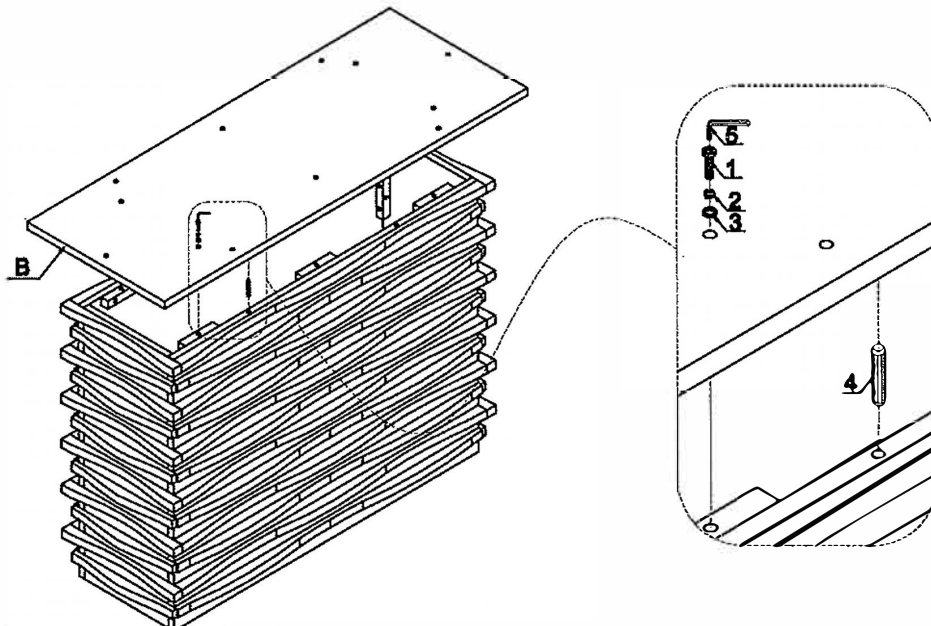

### STEP 3

Set on the TABLE TOP. Use FLAT WASHER, LOCK WASHER and BOLT. Fasten them tight by ALLEN WRENCH.

Insert the WOODEN DOWEL and set on the BASE. Use FLAT WASHER, LOCK WASHER and BOLT. Fasten them tight by ALLEN WRENCH.

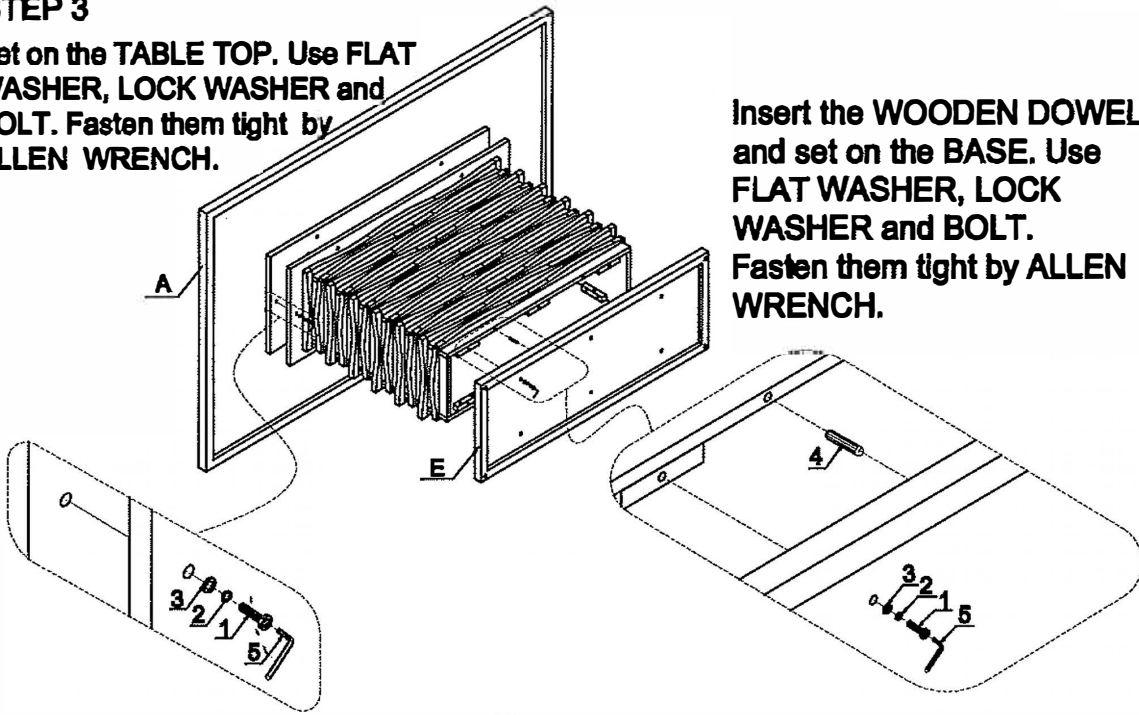

### STEP 4

Assembly Complete.

