

ASSEMBLY INSTRUCTIONS

DINING TABLE

ASSEMBLY
REQUIREMENTS

30 MINUTES
Assembly Time
Approximate

2-Person
Assembly

Tools Required
(Not Provided)

Philips Screwdriver

Thank you for purchasing our product!

Please refer and use this assembly instruction to assemble the product. Contact our customer service department in case there are any missing or damage parts or hardware. Replacement parts are normally shipped within 2 or 3 days.

PRODUCT PURCHASED THROUGH OUR AUTHORIZED VENDORS ONLY ARE ELIGIBLE FOR REPLACEMENT PARTS

We appreciate your business!

THIS PRODUCT IS FOR INDOOR AND HOUSEHOLD USE ONLY- NOT FOR COMMERCIAL USE.

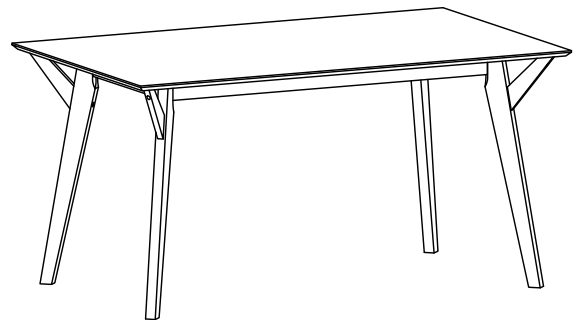

ASSEMBLY PREPARATION

1. Remove all packaging materials, staples and packing straps from the carton.
2. Refer to Parts List and Hardware List and ensure parts and hardware are correct before assembly.
3. Contact customer service for missing parts.
4. Place all wooden parts on a clean, flat and soft surface (e.g. carpet or rug) to prevent parts from getting scratched.

SAFETY PRECAUTION

1. KEEP ALL HARDWARE PARTS OUT OF REACH OF CHILDREN.
2. DISPOSE PLASTIC PACKAGING MATERIAL IMMEDIATELY TO AVOID ANY RISK OF SUFFOCATION TO CHILDREN AND ANIMALS.

TIPS FOR ASSEMBLY

1. Allow ample room for assembly and in close proximity to where product will be placed.
2. Assemble the product on a surface that does not scratch or damage the exterior gloss and finish of the furniture.
3. Identify all of the parts, hardware and quantities required for each step.
4. During assembly, do not over-tighten any fittings as this may cause damage.
5. DO NOT USE POWER TOOLS TO ASSEMBLE THIS PRODUCT.
6. Always place the product on a flat, level surface.
7. Do not sit or stand on the partially assembled product; only use the product for which it is intended.



CARE AND MAINTENANCE

- Wipe clean with a soft , dry cloth; avoid the use of harsh chemicals or household cleaners as they may damage the exterior finish of the furniture.
- **Hardware may loosen over time. Periodically , check that all connections are tight ; re-tighten as necessary.**
- Solid wood is impacted by heat and humidity fluctuations which may cause in small joint separations or hairline cracks; place the furniture away from direct sunlight and air conditioning vents, heating vents or units to protect the furniture.

ASSEMBLY INSTRUCTIONS

DINING TABLE

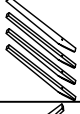
PARTS LIST

NO.	COMPONENT	QTY
1	TABLE TOP 	1
2	TABLE LEG 	4
3	TABLE LEG SUPPORT 	4

HARDWARE LIST

NO.	DESCRIPTION	QTY	EXTRA
A	ALLEN KEY M4 x 110mm 	1	
B	JCBC SCREW M6 x 70mm 	4	1
C	SPRING WASHER M6x13mm 	4	1
D	ALLEN KEY M5 x 65mm 	1	
E	JCBB SCREW M8 x 70mm 	8	2
F	SPRING WASHER 5/16 	8	2
G	FLAT WASHER 5/16 x 22mm 	8	2
H	CSK SCREW M4 x 28mm 	4	1
I	ADJUSTABLE LEG STUD M6x24mm 	4	2
J	WOOD BUTTON 10.5mm Ø 	4	1
K	WOOD BUTTON 14.5mm Ø 	4	1

EXTRA HARDWARE FOR SPARE USE

STEP 1

- a) Insert Screw (B) fitted with Spring Washer (C) through the screw hole on Table leg (2) into the screw holes on Table Leg Support (3) to fasten (3) to (2). Use Allen Key (A) to drive (B). Do not over tighten (B).

- b) Use Wood Button (K) to conceal screw hole.

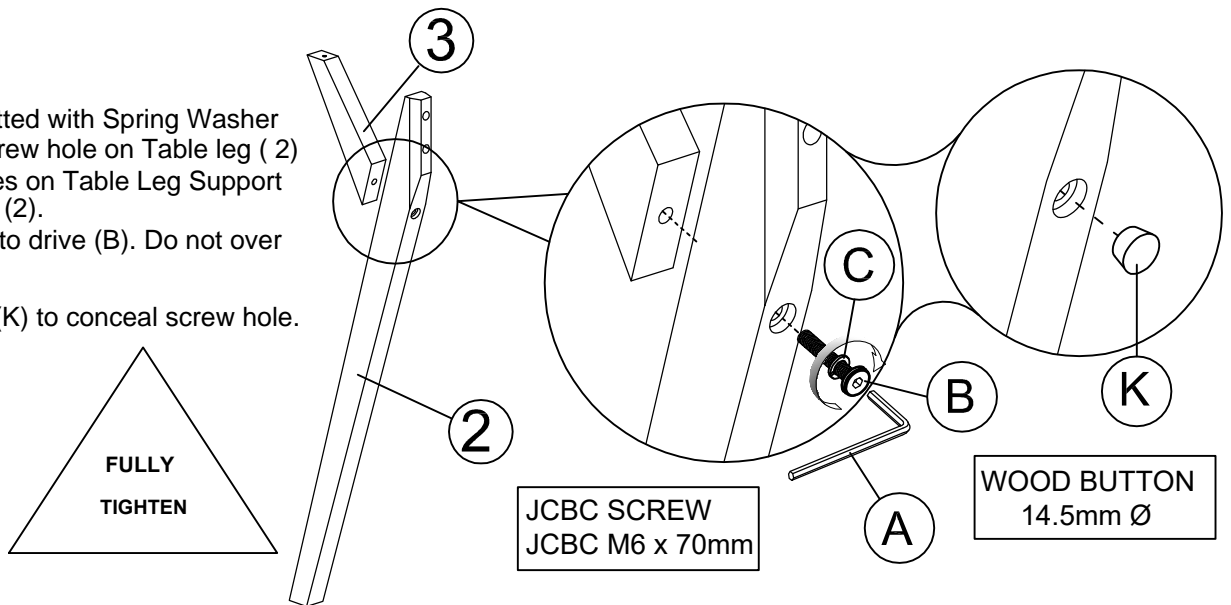

STEP 2

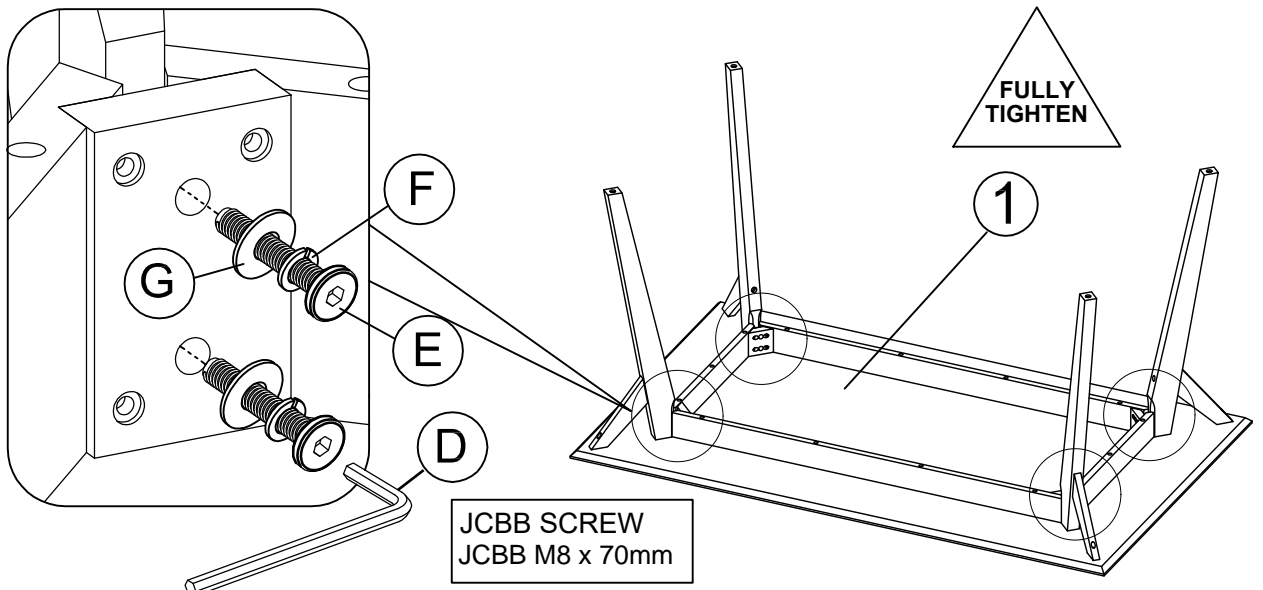

- a) With the assistance of another person, place Table Top (1) bottom-side up on a flat surface and material that does not scratch or and damage the part.
- b) Position Table leg and Leg Support assembly from STEP 1 against the corner of the table aprons and align the screw holes on (2) to the screw holes on the corner block.
- c) Insert Screw (E) fitted with Spring Washer (F) and Flat Washer (G) through each hole on the corner block into screw hole on (2). Use Allen Key (D) to drive (E) to fasten Table Leg (2) to corner block. Do not tighten (E) completely until both screws are in place on each leg. Do not over -tighten.

ASSEMBLY INSTRUCTIONS

DINING TABLE

STEP 3

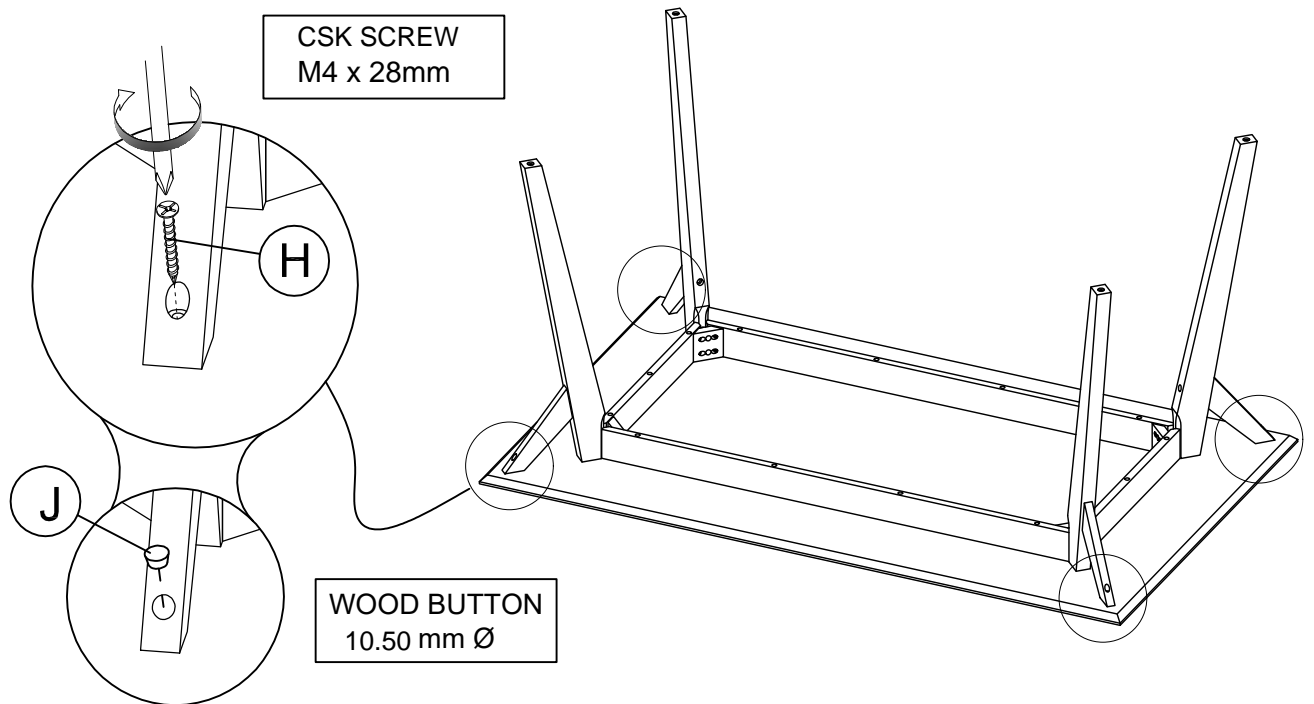

- Use Screw (H) to fasten each Table Leg Support to Table Top. Tighten Screw (H) completely. Do not over-tighten.
- Use Wood Button (J) to conceal screw hole on each Table leg Support.

STEP 4

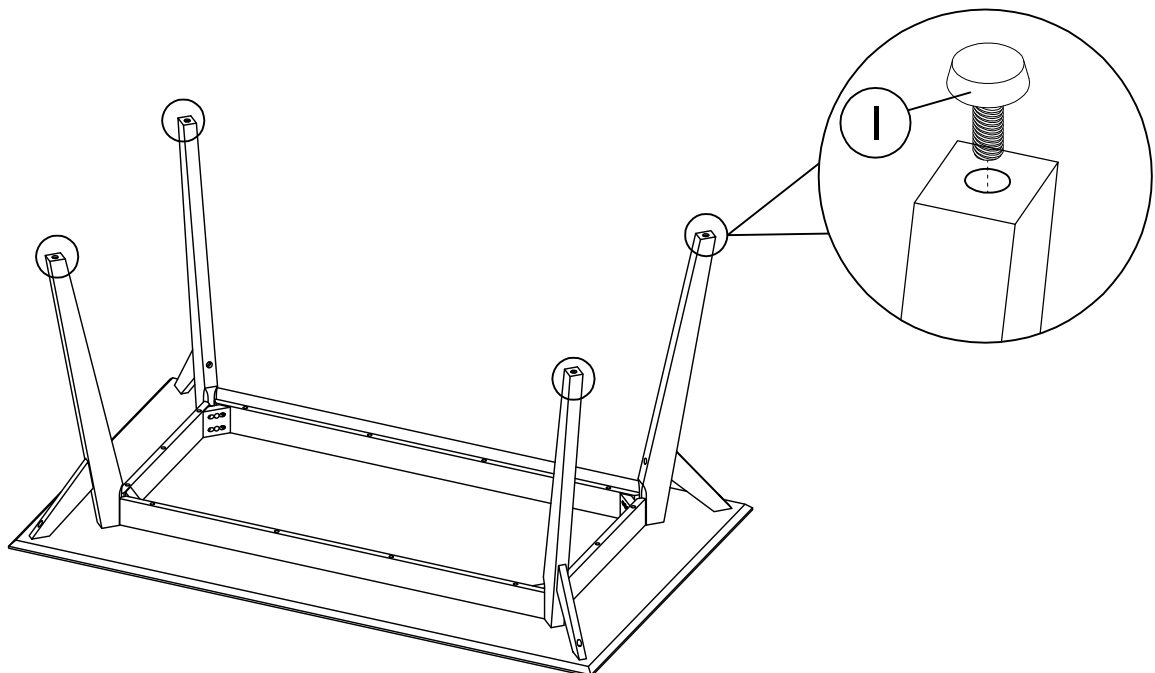

- Screw in Adjustable Leg Stud (I) into the screw on each leg
- Set the table right-side up. Adjust Leg Stud to level the table if necessary.

The assembly of the table is complete.