

Kiwako Bookcase

Assembly Instructions

Montageanleitung

Instrucciones de ensamblaje

Instructions de montage

Istruzioni di montaggio



English

WARNING

Serious or fatal crushing injuries can occur from furniture tip-over. **ALWAYS** secure this furniture to the wall using tip-over restraints. To further reduce the risk of serious injury and death from tip-overs:

- Place heaviest items in the lower drawer.
- Do not set TVs or other heavy objects on top of this product.
- Never let children climb or hang on drawers, doors, or shelves.

Deutsch

ACHTUNG

Umfallende Möbelstücke können lebensgefährlich sein.

Um diesem Risiko zu entgehen, muss das Möbel **UNBEDINGT** mit dem beigegepackten Kippschutz an der Wand befestigt werden.

Um das Risiko schwerer oder gar tödlicher Verletzungen durch umkippende Möbelstück weiter zu mindern, bitte Folgendes beachten:

- schwere Gegenstände immer in Bodennähe aufbewahren.
- Fernsehgeräte oder andere schwere Geräte niemals auf das Produkt stellen.
- Kindern niemals erlauben, auf Schubladen, Türen und Regale zu klettern oder sich daranzuhängen.

Español

ADVERTENCIA

Si el mueble vuelca, puede provocar lesiones muy graves e incluso mortales.

Fija SIEMPRE este mueble a la pared utilizando los accesorios antivuelco.

Para reducir aún más el riesgo de lesiones graves o incluso mortales causadas por el vuelco del mueble:

- Guarda los objetos más pesados en el cajón inferior.
- No pongas un TV u otros objetos pesados encima de este producto.
- Evita que los niños suban encima del mueble o se cuelguen de los cajones, las puertas o los estantes.

Français

ATTENTION

Risque de blessures graves ou mortelles en cas de basculement du meuble.

TOUJOURS fixer ce meuble au mur à l'aide des fixations antibasculement. Pour encore réduire les risques de blessures graves ou mortelles dus au basculement du meuble:

- Placer les objets les plus lourds dans le tiroir du bas.
- Ne jamais laisser les enfants grimper ou s'accrocher aux tiroirs, portes ou tablettes.

Italiano

AVVERTENZA

Se il mobile si ribalta può causare lesioni da schiacciamento gravi o mortali.

Fissa **SEMPRE** questo mobile alla parete usando i componenti di sicurezza.

Per ridurre ulteriormente il rischio di lesioni gravi o mortali causate dal ribaltamento:

- Metti gli oggetti più pesanti nel cassetto inferiore.
- Non collocare la TV o altri oggetti pesanti sopra questo prodotto.
- Evita che i bambini si appendano o si arrampichino sui cassetti, sulle ante o sui ripiani.

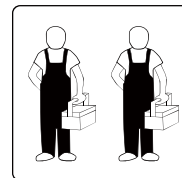



English

WARNING!

1. When installing the product, use a soft surface (such as carpet or cardboard) to avoid scratching or damaging the surface of the product.
2. Please try to use a manual screwdriver instead of electric screw driver. A manual screwdriver can be used to better control the tightness of the screws.
3. Do not use any glue.
4. The product is unstable before it is assembled. Please pay attention to the product installation sequence, and align all screws and screw holes before tightening.
5. The structure of this product can not meet the requirements of children climbing.

Deutsch

ACHTUNG!

1. Verwenden Sie bei der Montage des Produkts eine weiche Unterlage (z. B. Teppich oder Pappe), um Kratzer oder Beschädigungen auf der Oberfläche des Produkts zu vermeiden.
2. Bitte verwenden Sie nach Möglichkeit einen Schraubendreher von Hand anstelle eines elektrischen Schraubendrehers. Mit einem Handschraubendreher lässt sich die Festigkeit der Schrauben besser kontrollieren.
3. Verwenden Sie keinen Klebstoff.
4. Das Produkt ist vor der Montage instabil. Bitte beachten Sie die Montagereihenfolge des Produkts und richten Sie alle Schrauben und Schraublöcher aus, bevor Sie sie festziehen.
5. Die Konstruktion dieses Produkts ist nicht für das Klettern von Kindern ausgelegt.

Español

ADVERTENCIA!

1. Al instalar el producto, utilice una superficie blanda (como alfombra o cartón) para evitar rayar o dañar la superficie del producto.
2. Utilice preferentemente un destornillador manual en lugar de uno eléctrico. Un destornillador manual permite controlar mejor el apriete de los tornillos.
3. No utilice ningún tipo de pegamento.
4. El producto es inestable antes de ser montado. Preste atención a la secuencia de instalación del producto y alinee todos los tornillos y agujeros antes de apretarlos.
5. La estructura de este producto no está diseñada para que los niños trepen por él.

Français

ATTENTION!

1. Lors de l'installation du produit, utilisez une surface molle (comme un tapis ou du carton) pour éviter de rayer ou d'endommager la surface du produit.
2. Veuillez essayer d'utiliser un tournevis manuel plutôt qu'un tournevis électrique. Un tournevis manuel permet de mieux contrôler le serrage des vis.
3. N'utilisez aucune colle.
4. Le produit est instable avant son assemblage. Veuillez respecter l'ordre d'installation du produit et alignez toutes les vis et tous les trous avant de serrer.
5. La structure de ce produit n'est pas conçue pour supporter que des enfants grimpent dessus.

Italiano

AVVERTENZA!

1. Durante l'installazione del prodotto, utilizzare una superficie morbida (come un tappeto o del cartone) per evitare di graffiare o danneggiare la superficie del prodotto.
2. Si prega di utilizzare un cacciavite manuale invece di un cacciavite elettrico. Un cacciavite manuale permette di controllare meglio la tensione delle viti.
3. Non utilizzare alcun tipo di colla.
4. Il prodotto è instabile prima del montaggio. Prestare attenzione alla sequenza di installazione del prodotto e allineare tutte le viti e i fori delle viti prima di serrarli.
5. La struttura di questo prodotto non è adatta per sopportare il peso di bambini che ci si arrampicano.

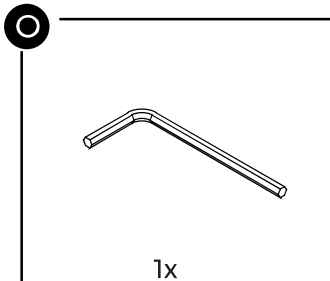
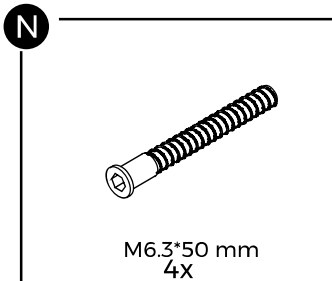
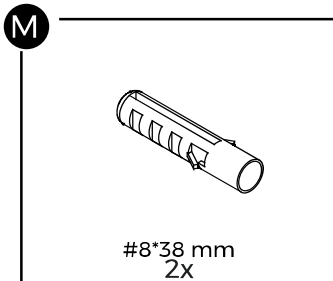
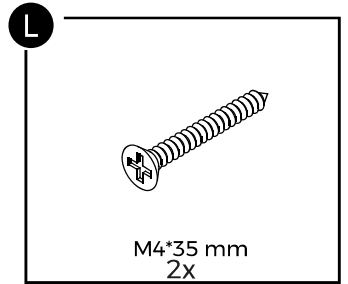
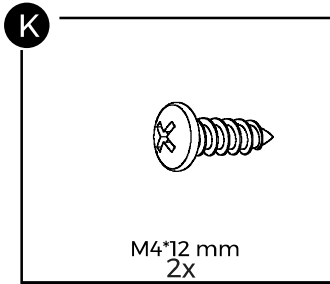
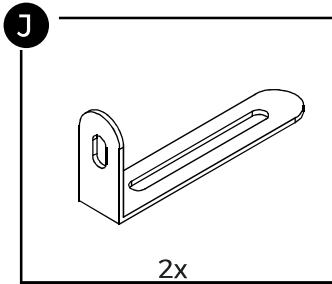
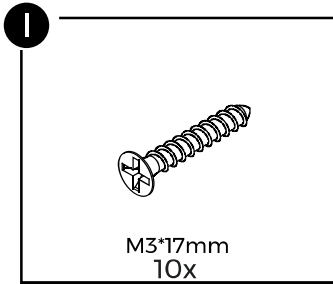
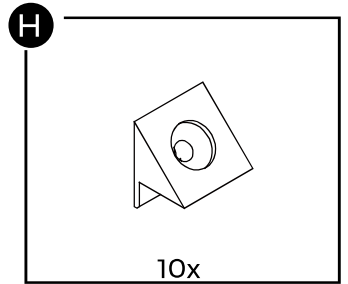
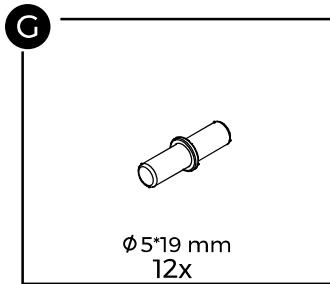
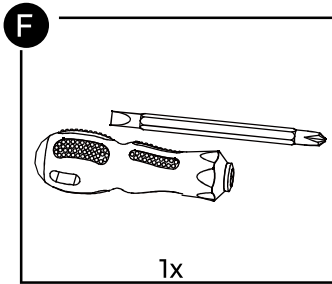
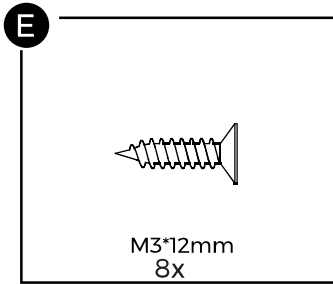
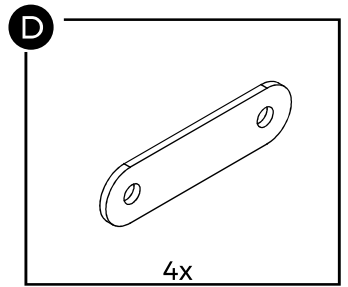
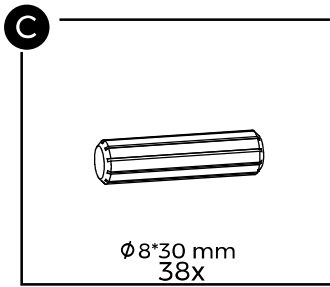
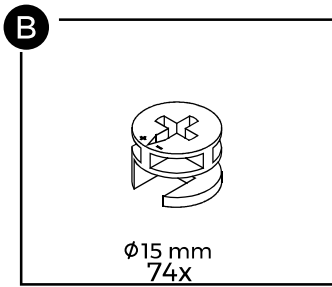
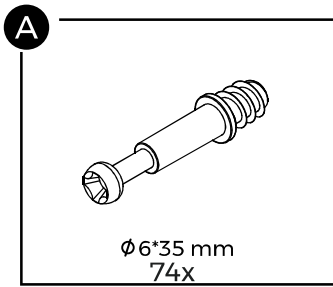

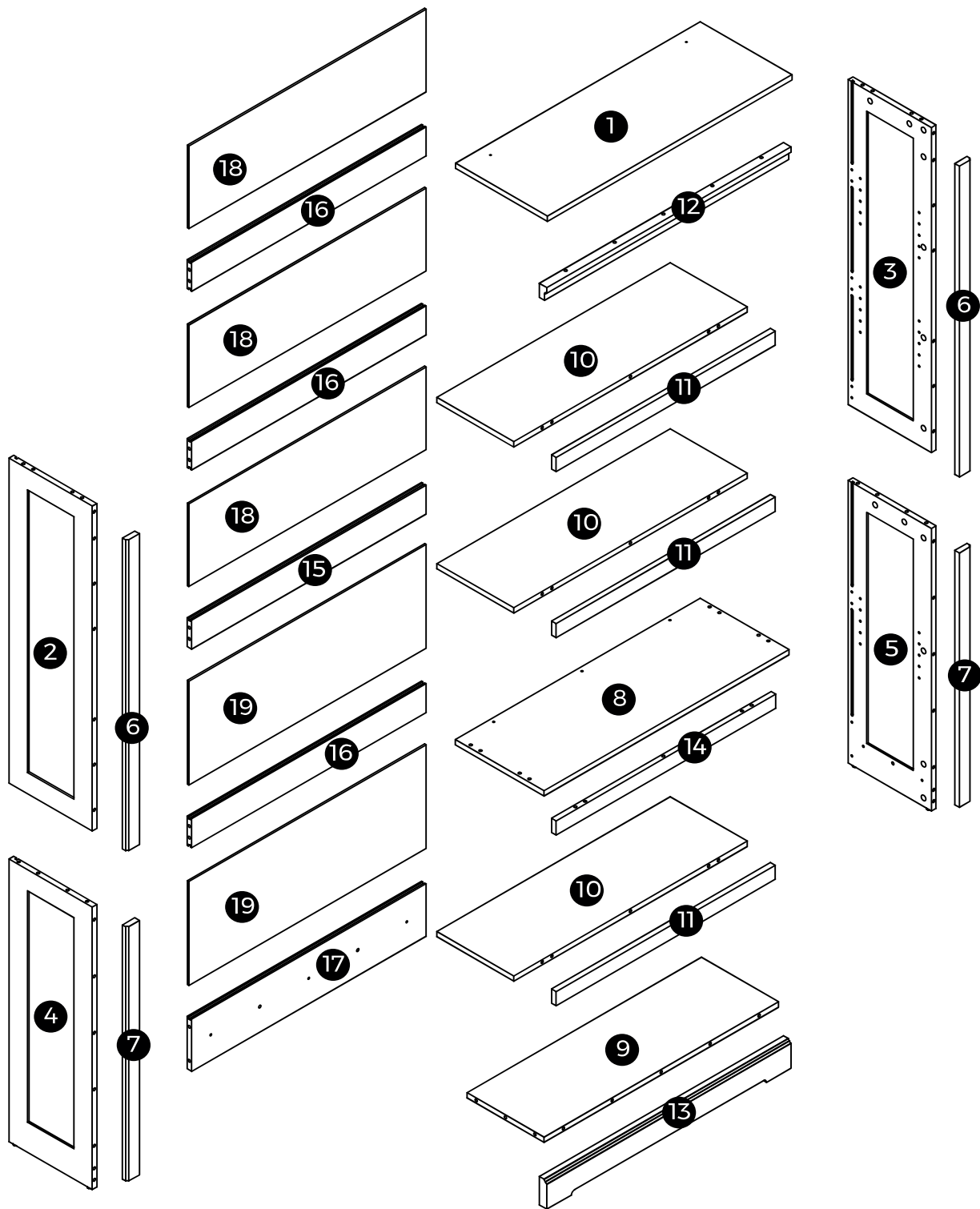



1

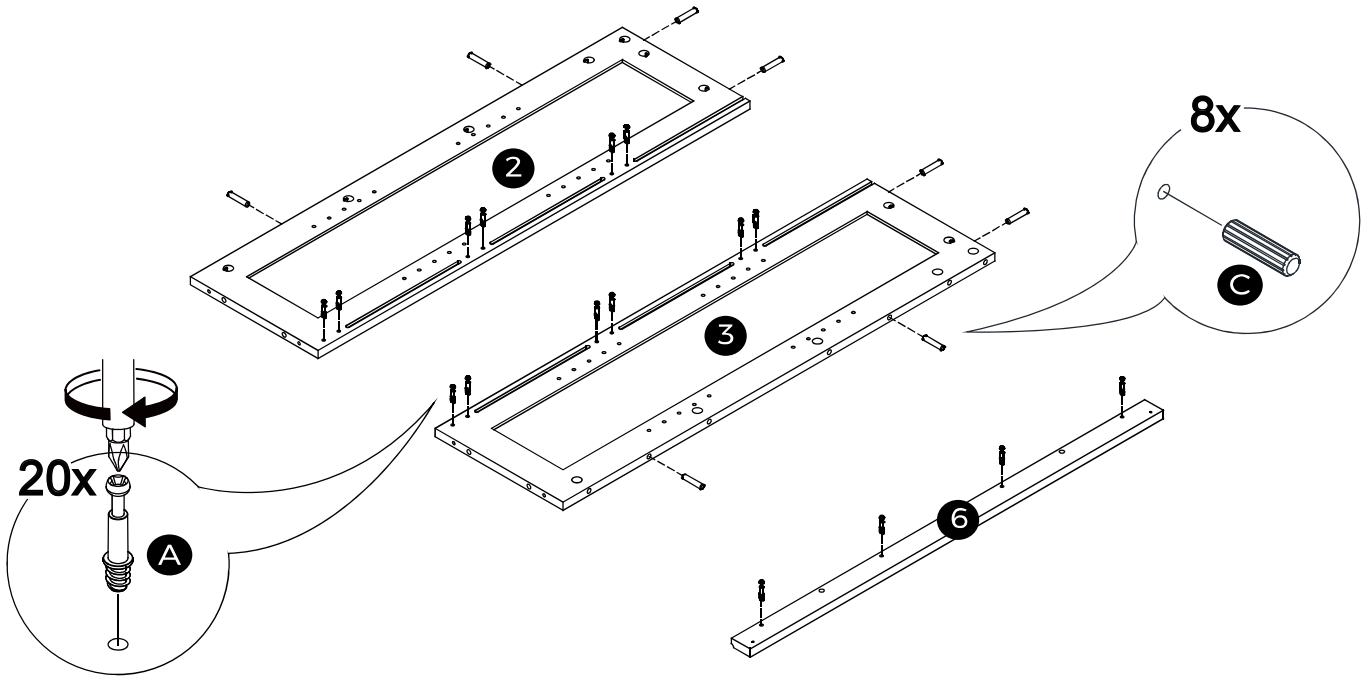

2

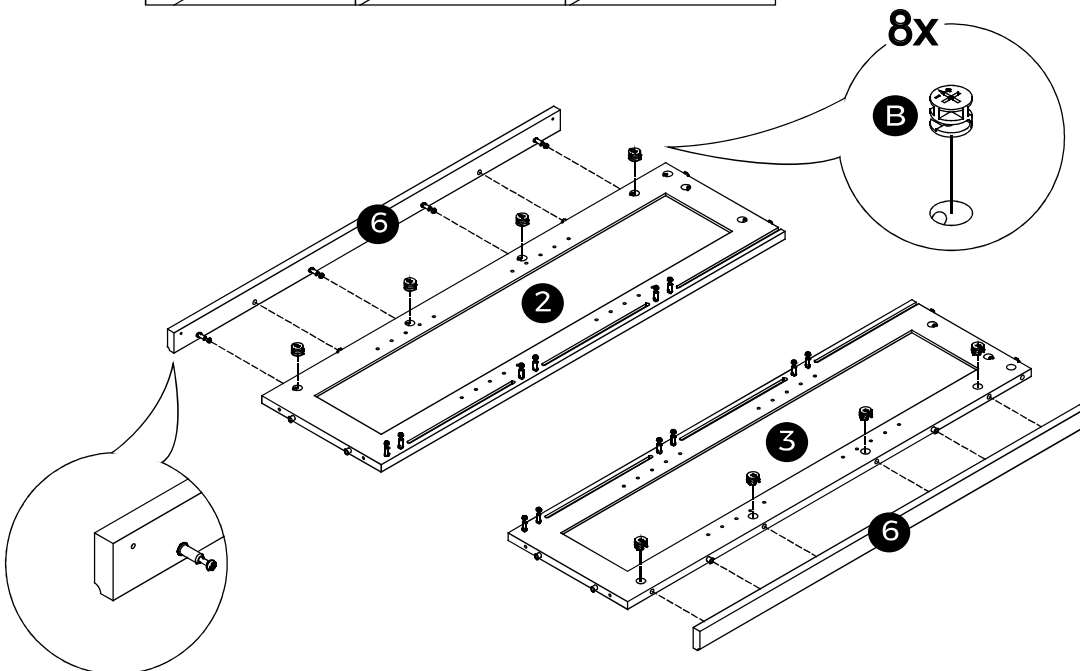
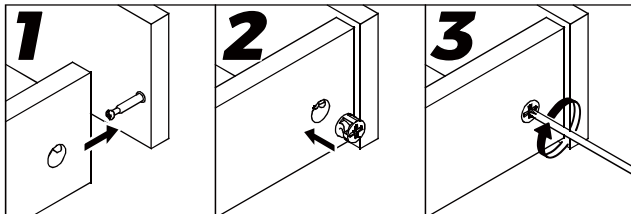

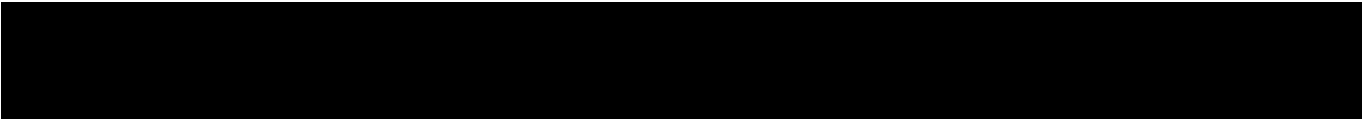

3

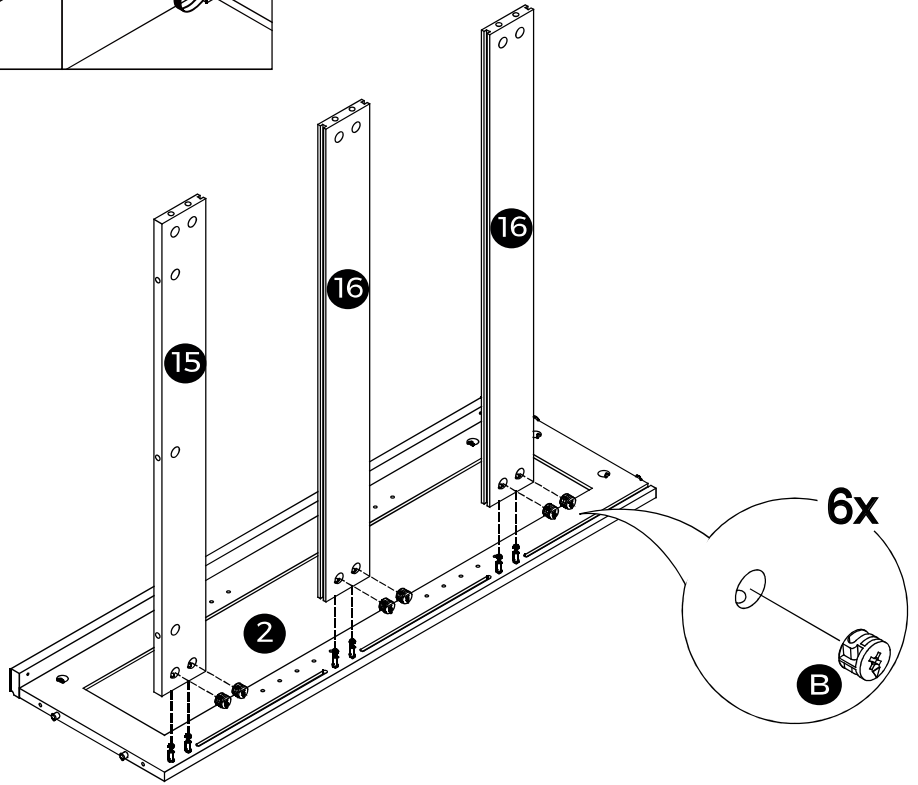
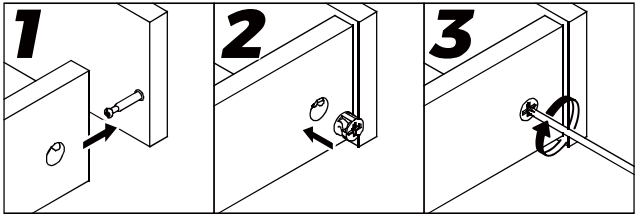

4

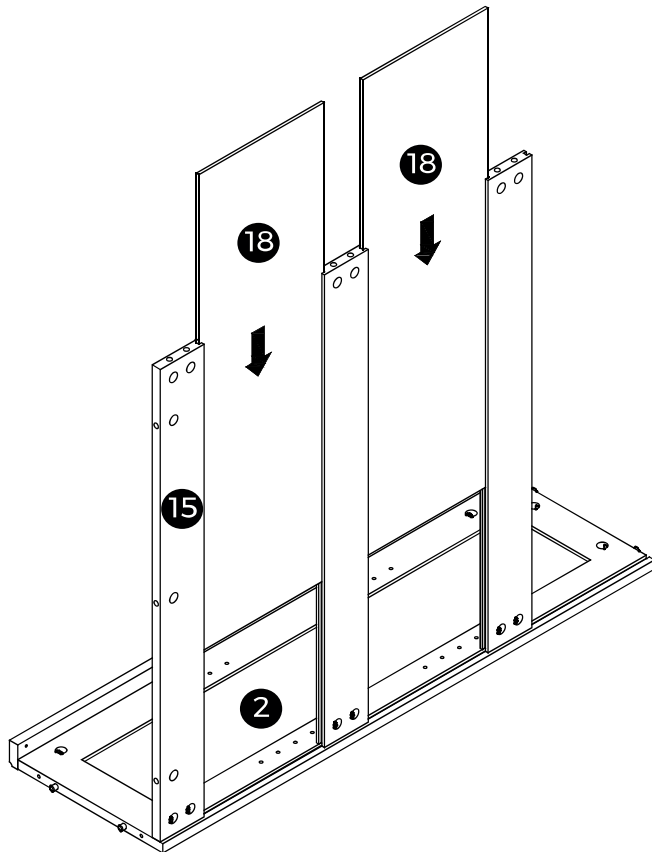

5

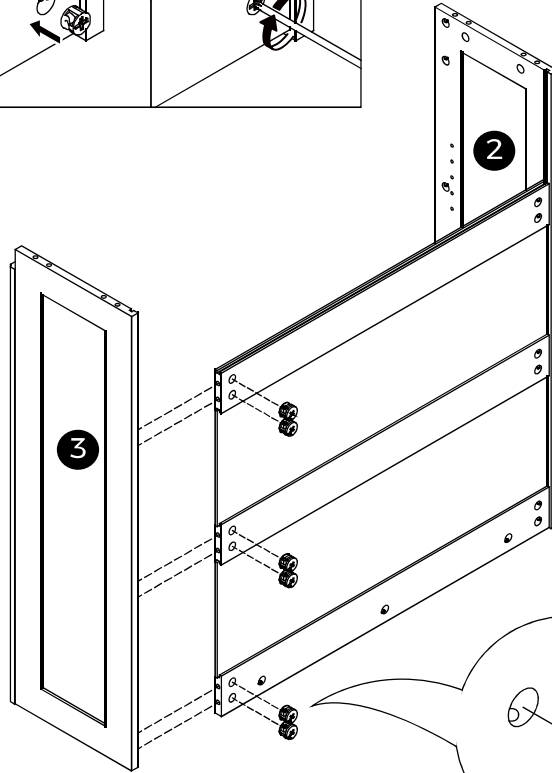
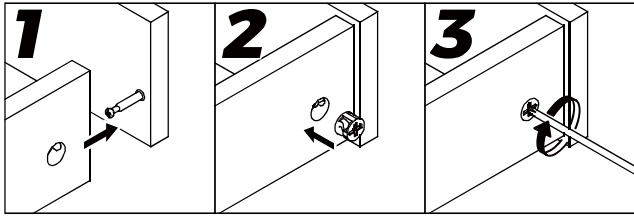

90°

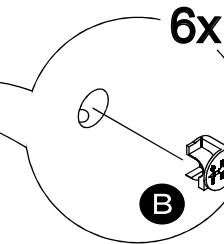
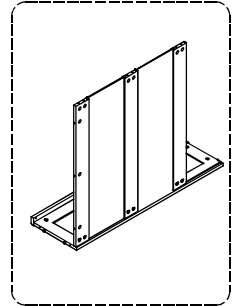

6

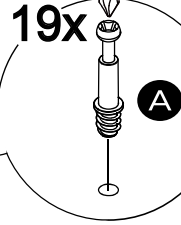
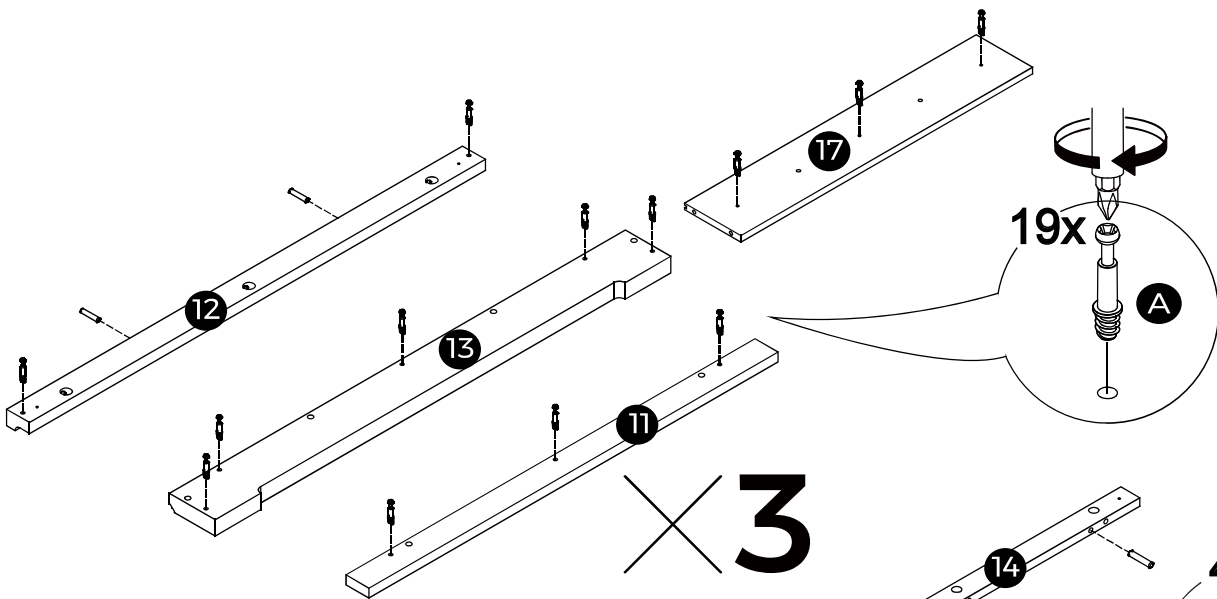

× 3

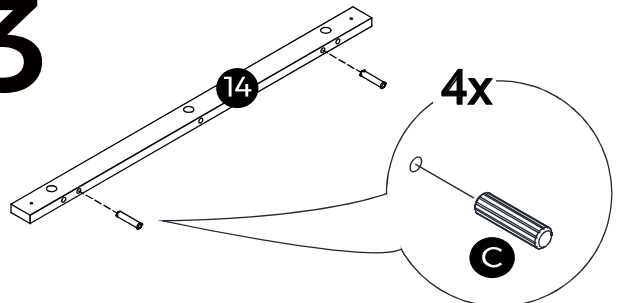

7

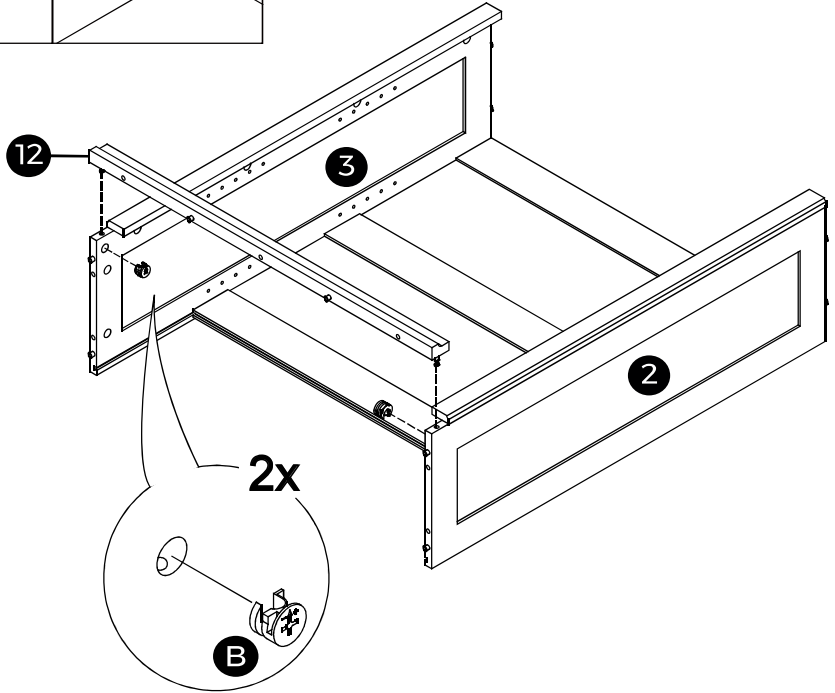
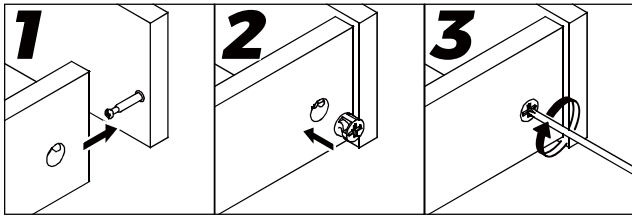

8

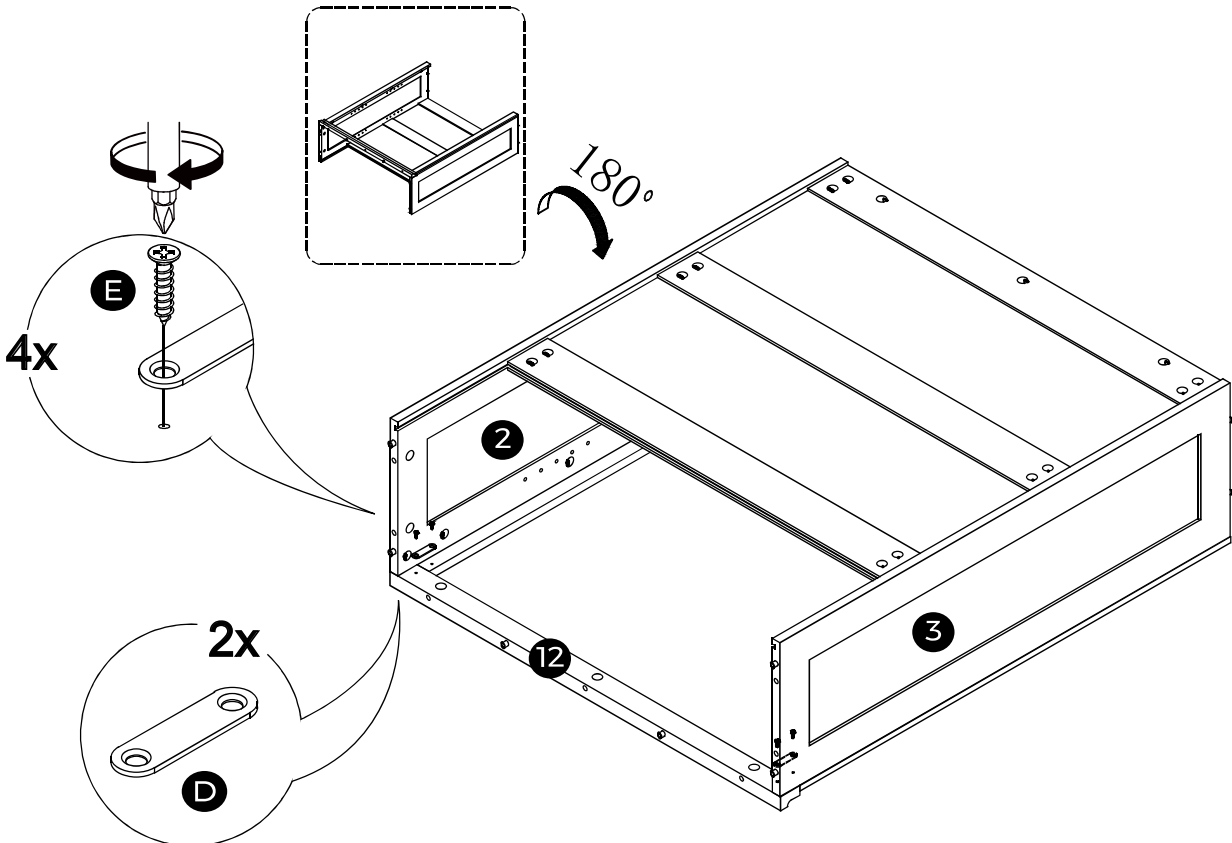

9

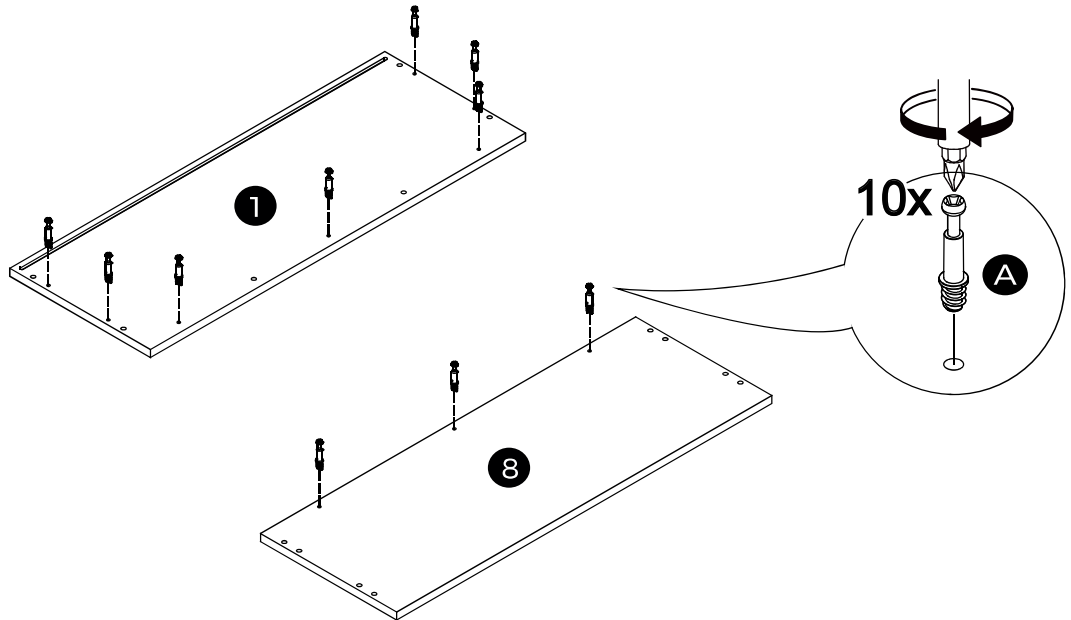

10

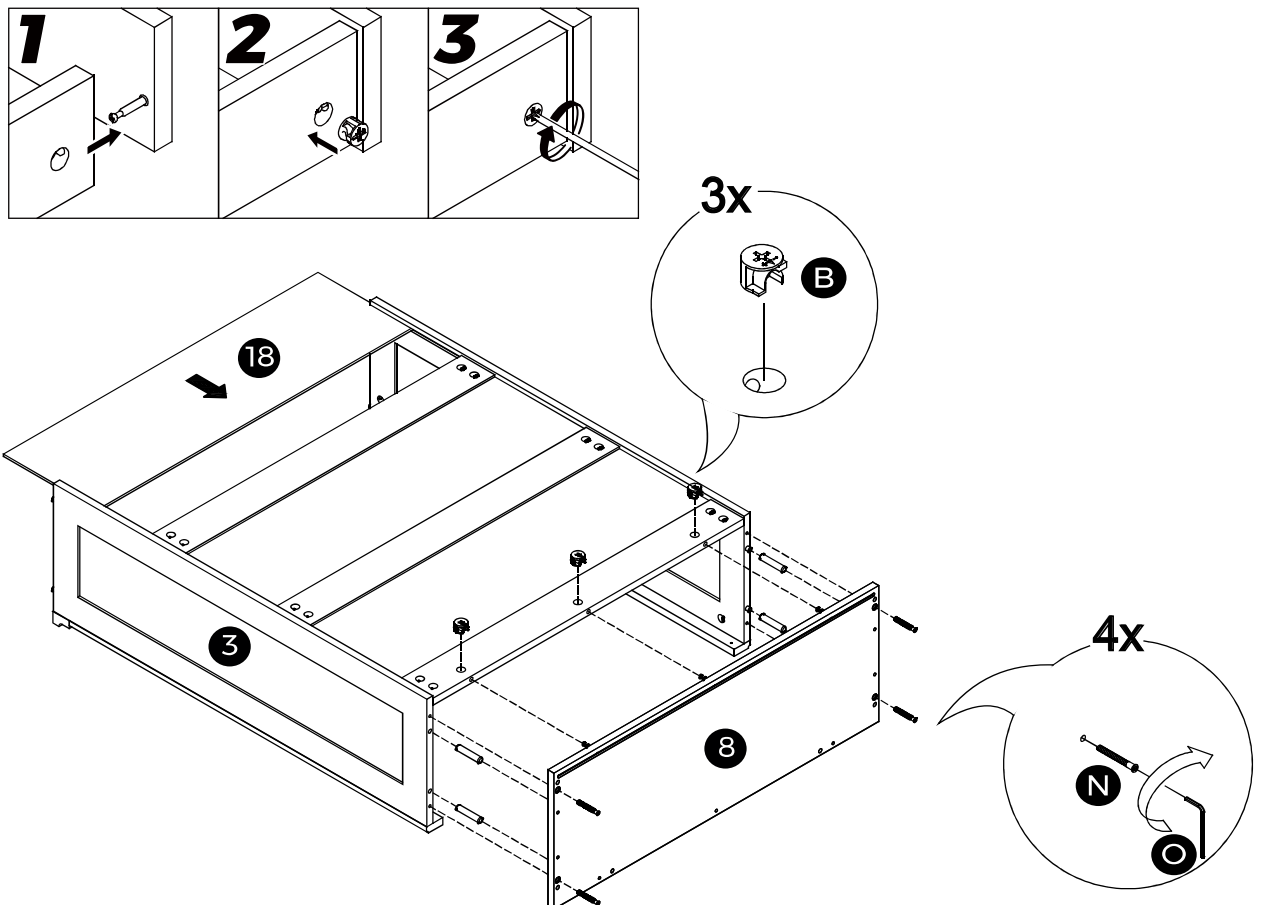

11

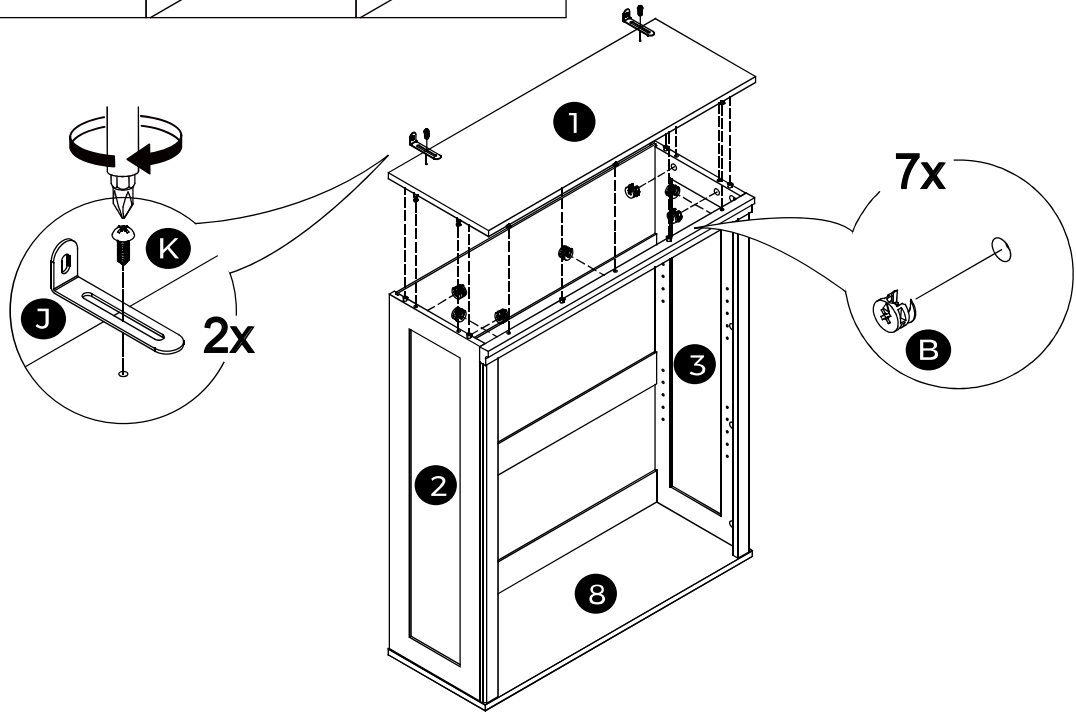
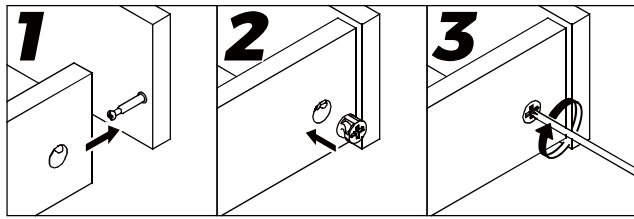

12

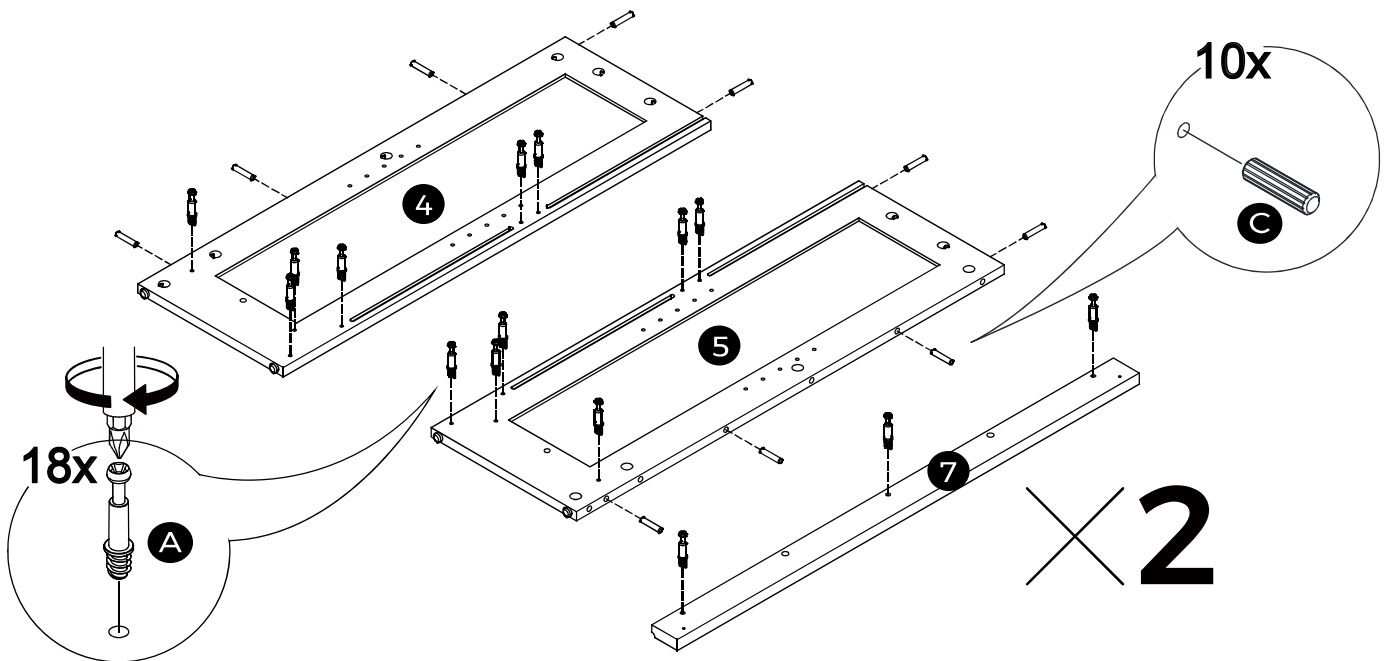

13

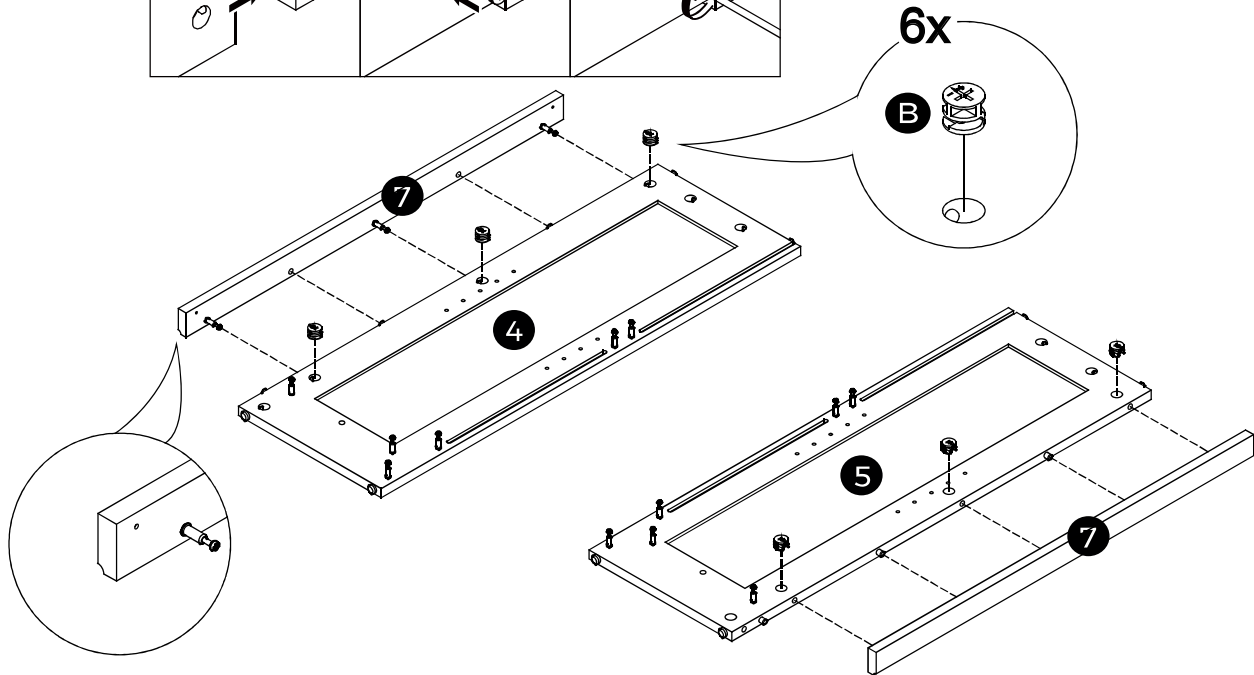
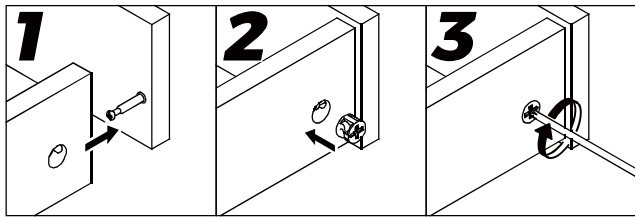

14

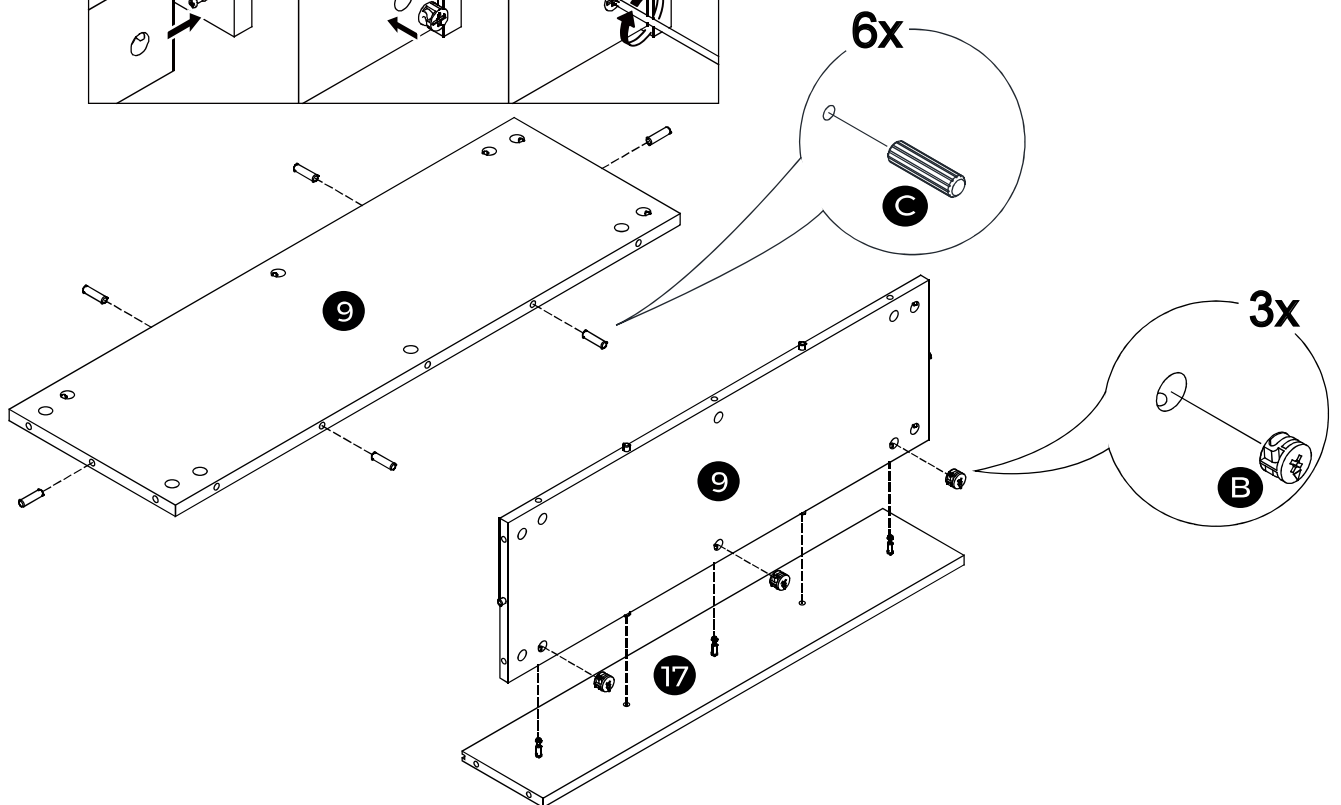
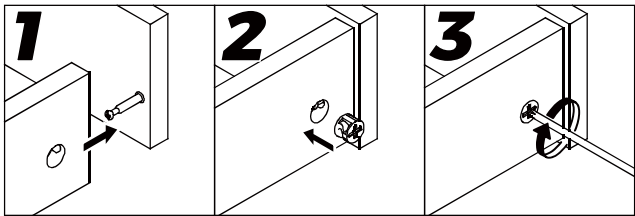

15

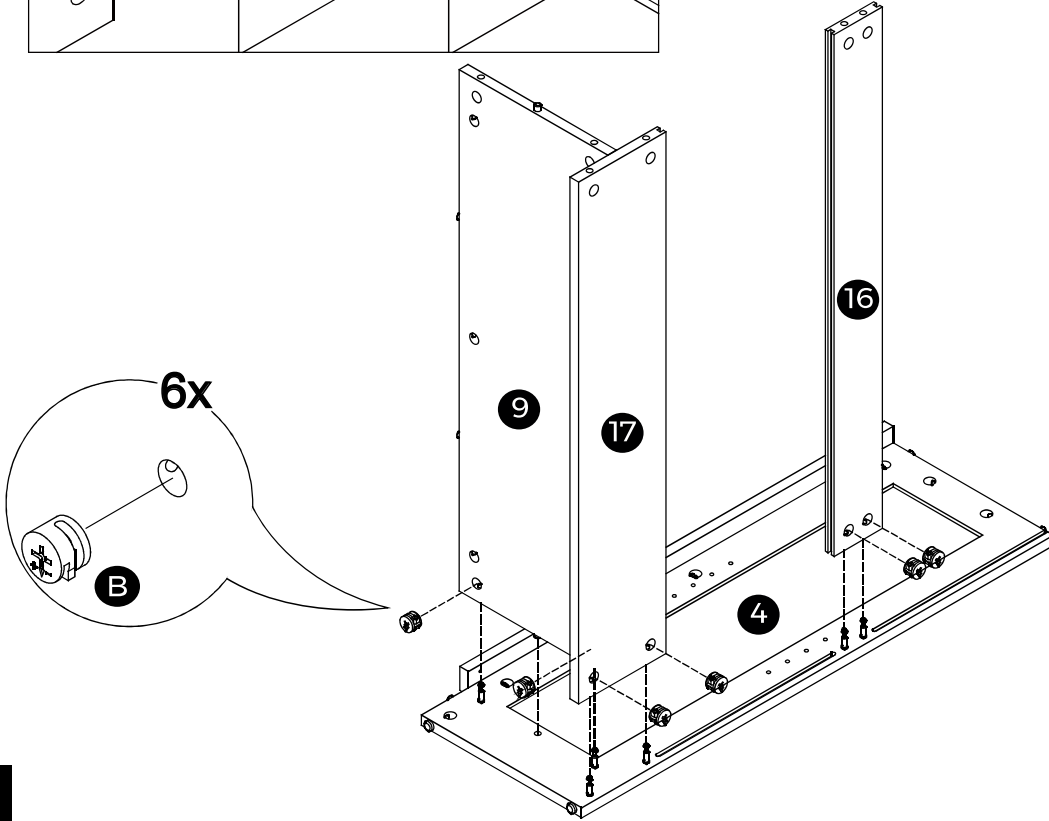
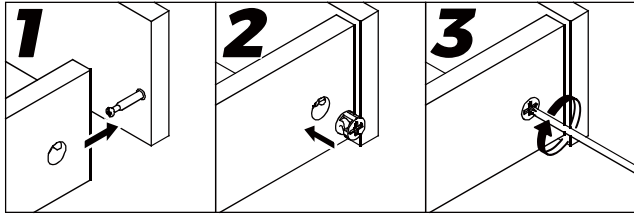

16

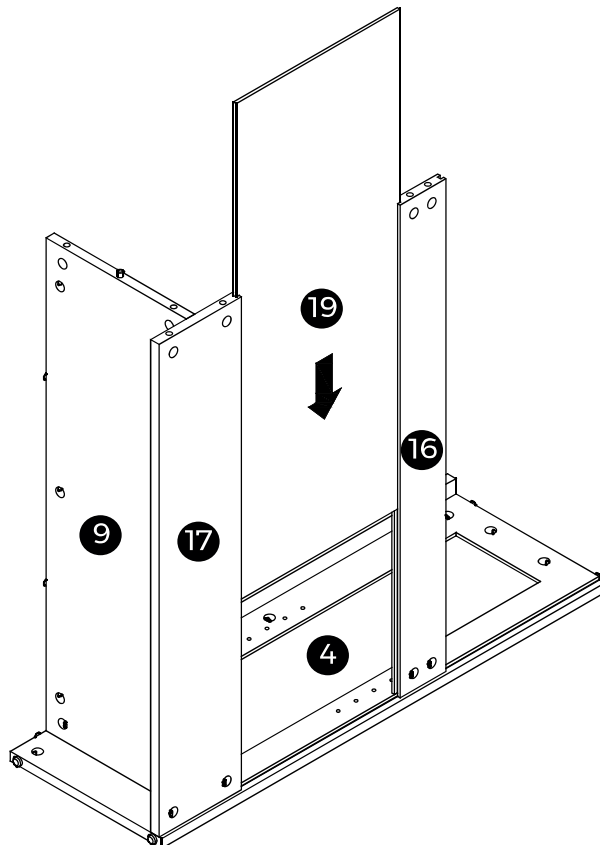

17

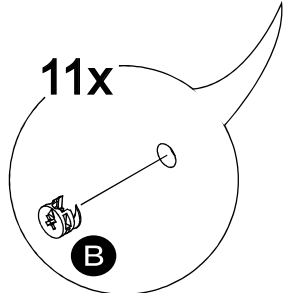
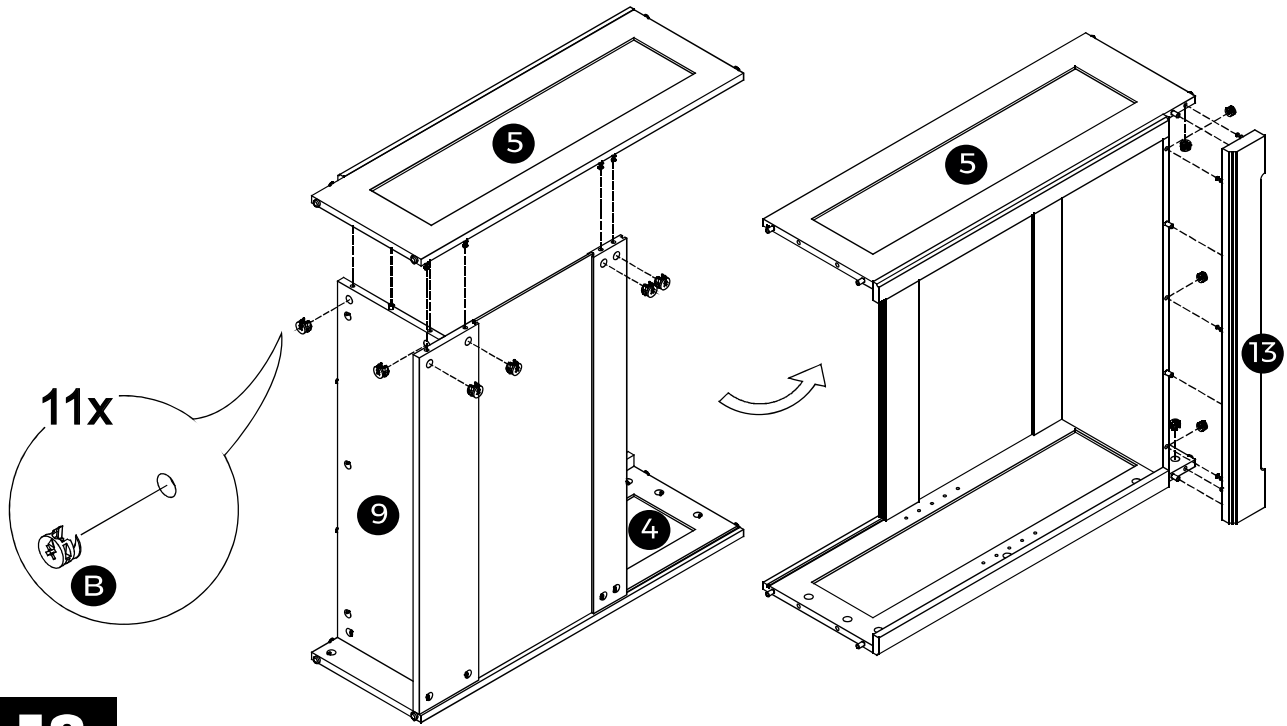
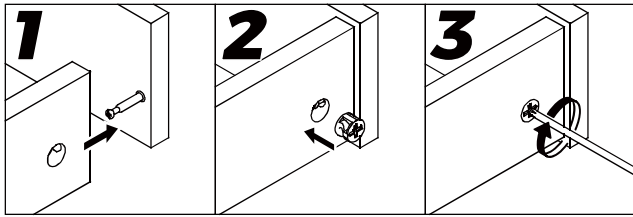

18

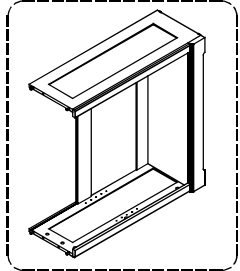
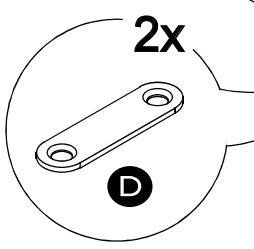
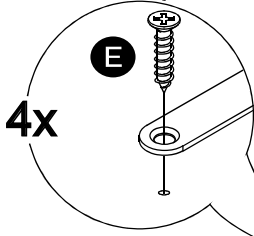
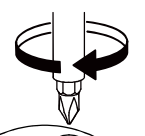
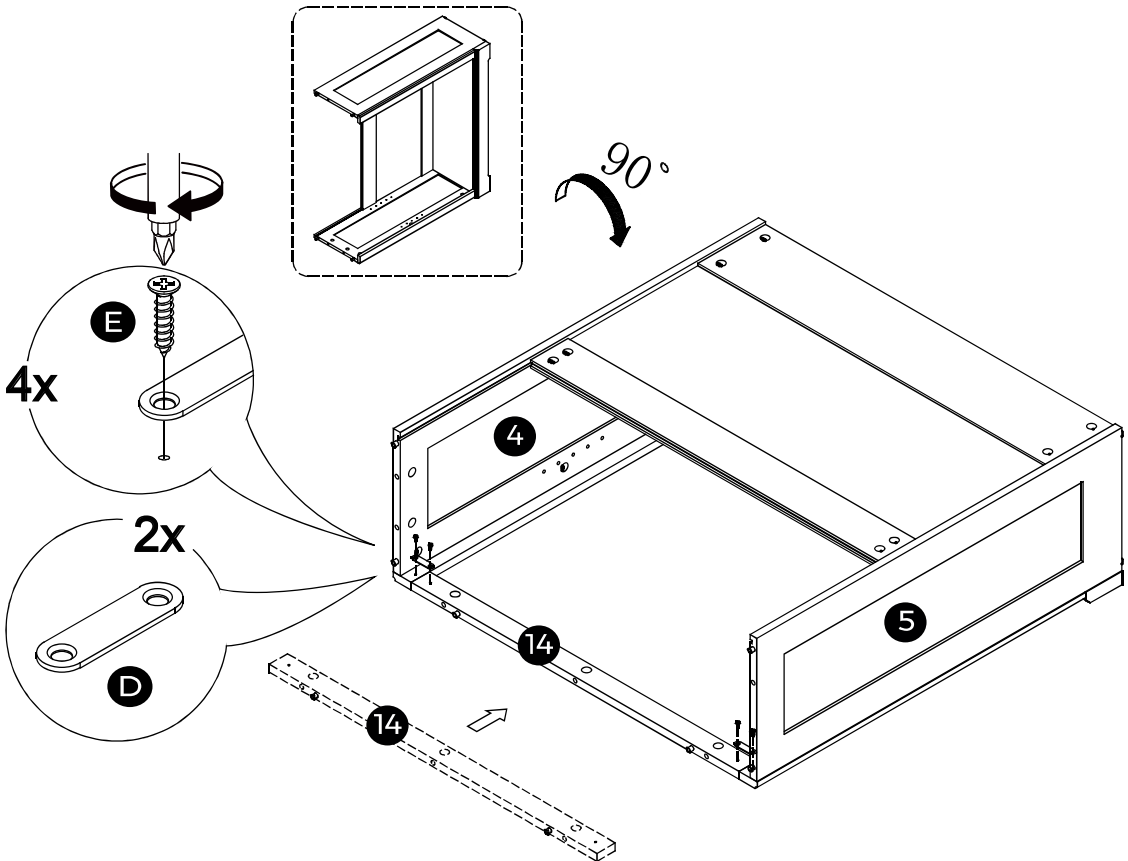

19

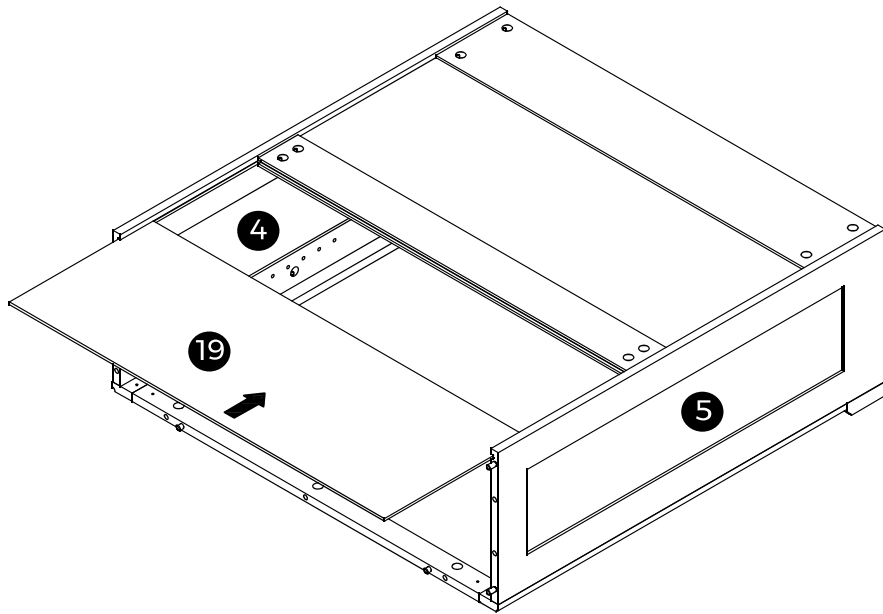

20

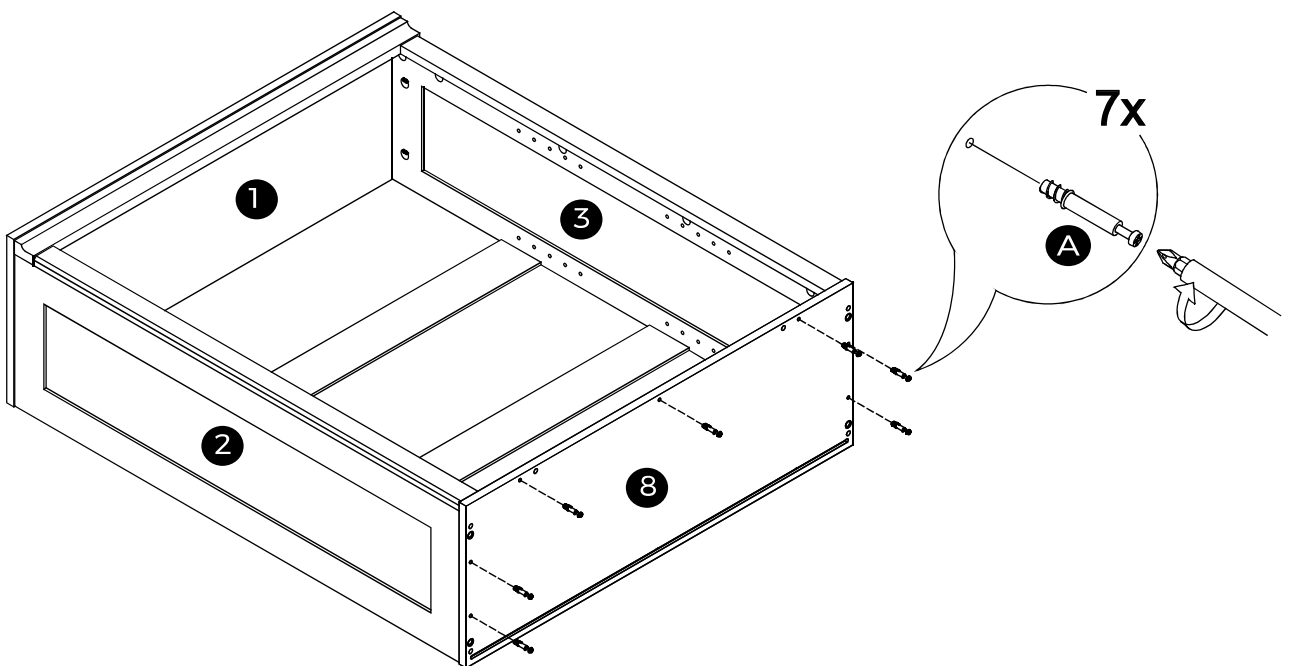

21

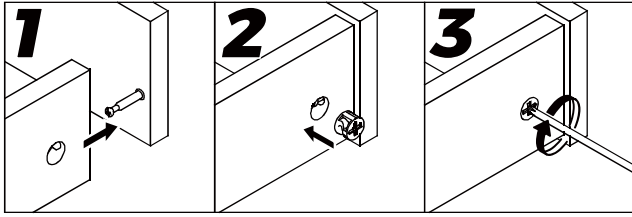

Method of installation 1:
Méthode d'installation 1 :

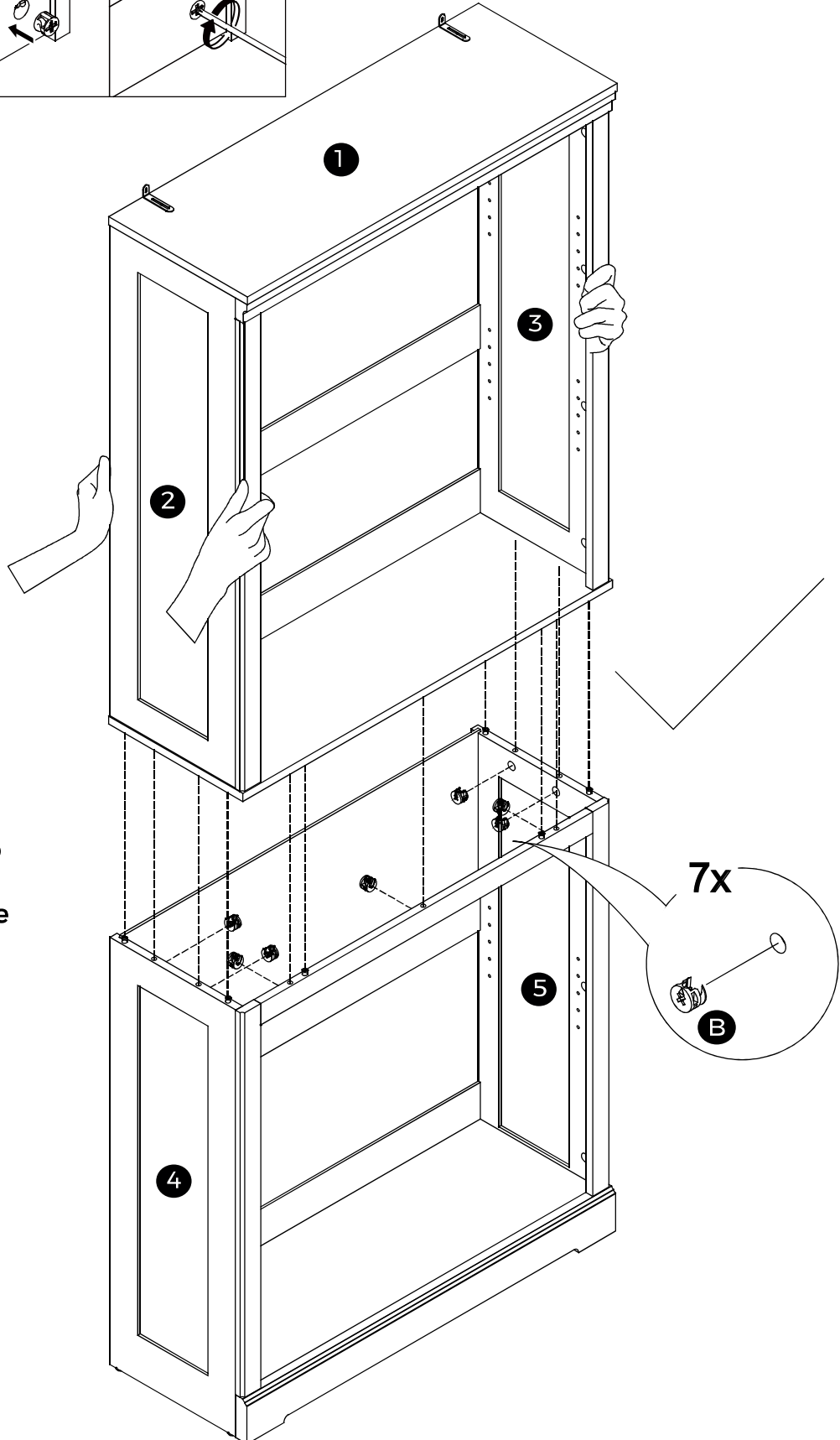

Note: This step requires two people to lift and install it.
Note : Cette étape nécessite deux personnes pour lever et l'installer.

21

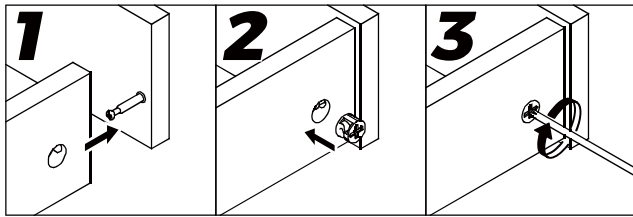

Method of installation 2:
Méthode d'installation 2 :

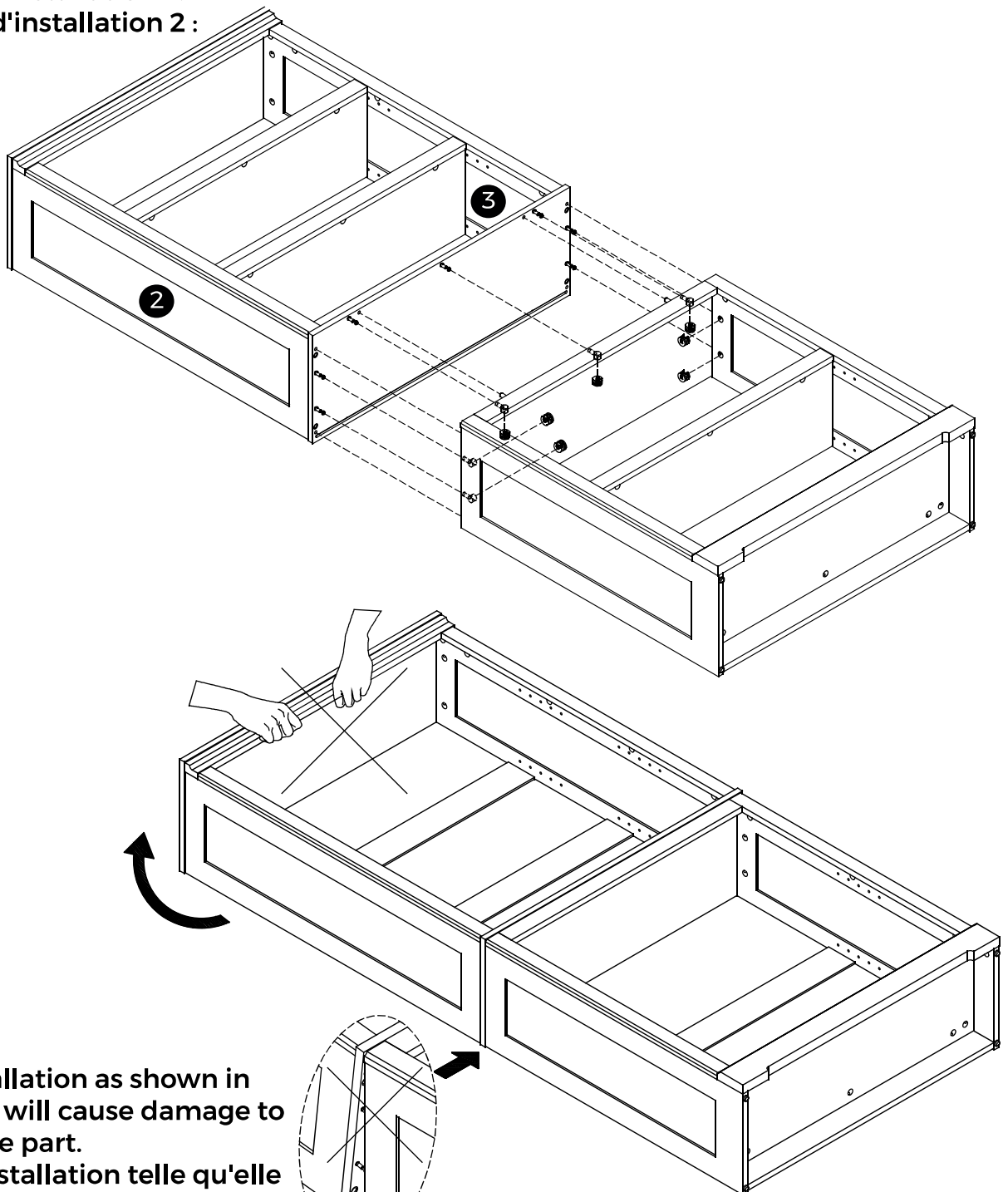

Note: Installation as shown in the figure will cause damage to the middle part.

Note : L'installation telle qu'elle est montrée dans la figure endommagera la partie centrale.

***Note:** Two people are required to operate the installation as shown in the figure. The key point is to hold the plates ②&④ and ③&⑤ with both hands at the same time.

Note : Deux personnes sont nécessaires pour réaliser l'installation telle qu'elle est montrée dans la figure. Le point clé consiste à saisir les plaques ② et ④ ainsi que ③ et ⑤ avec les deux mains simultanément.

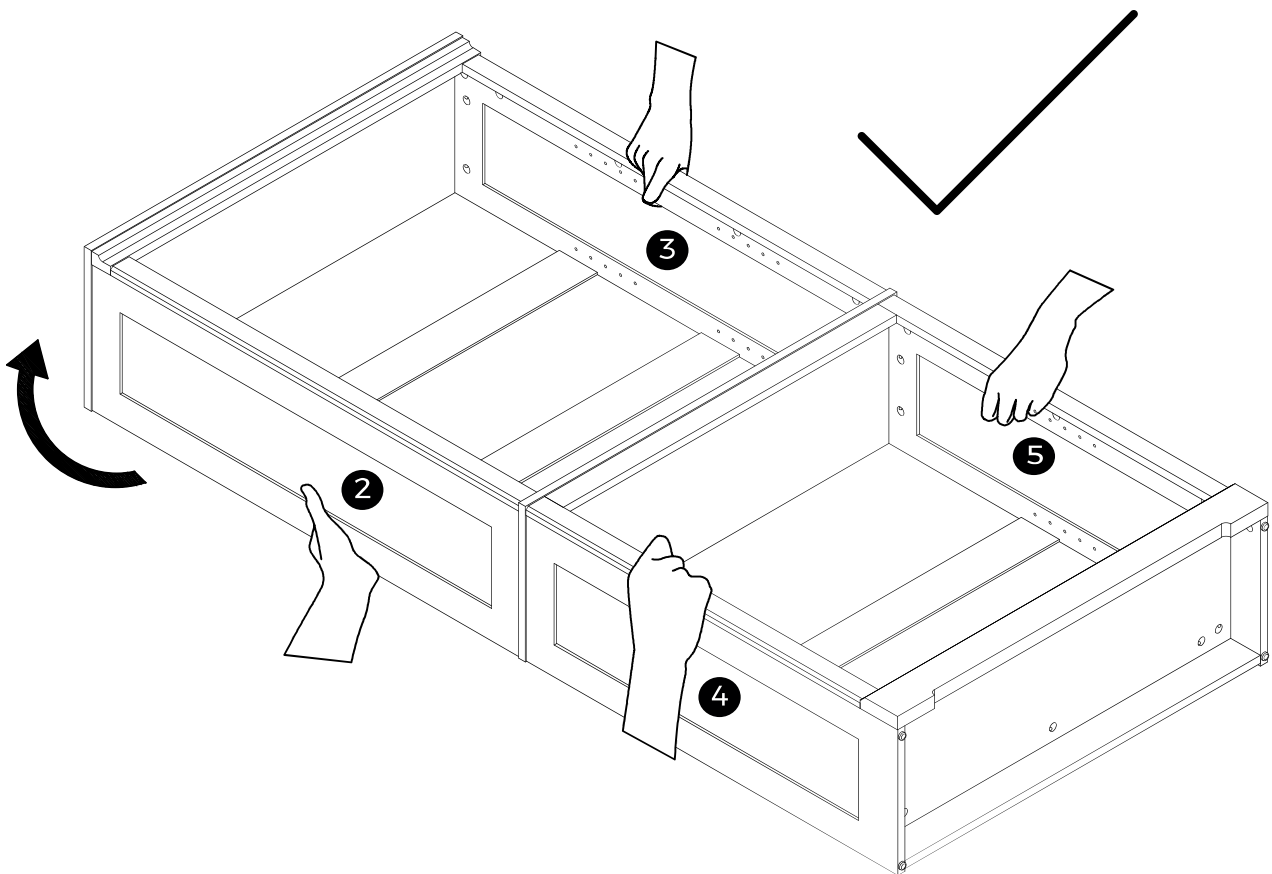

22

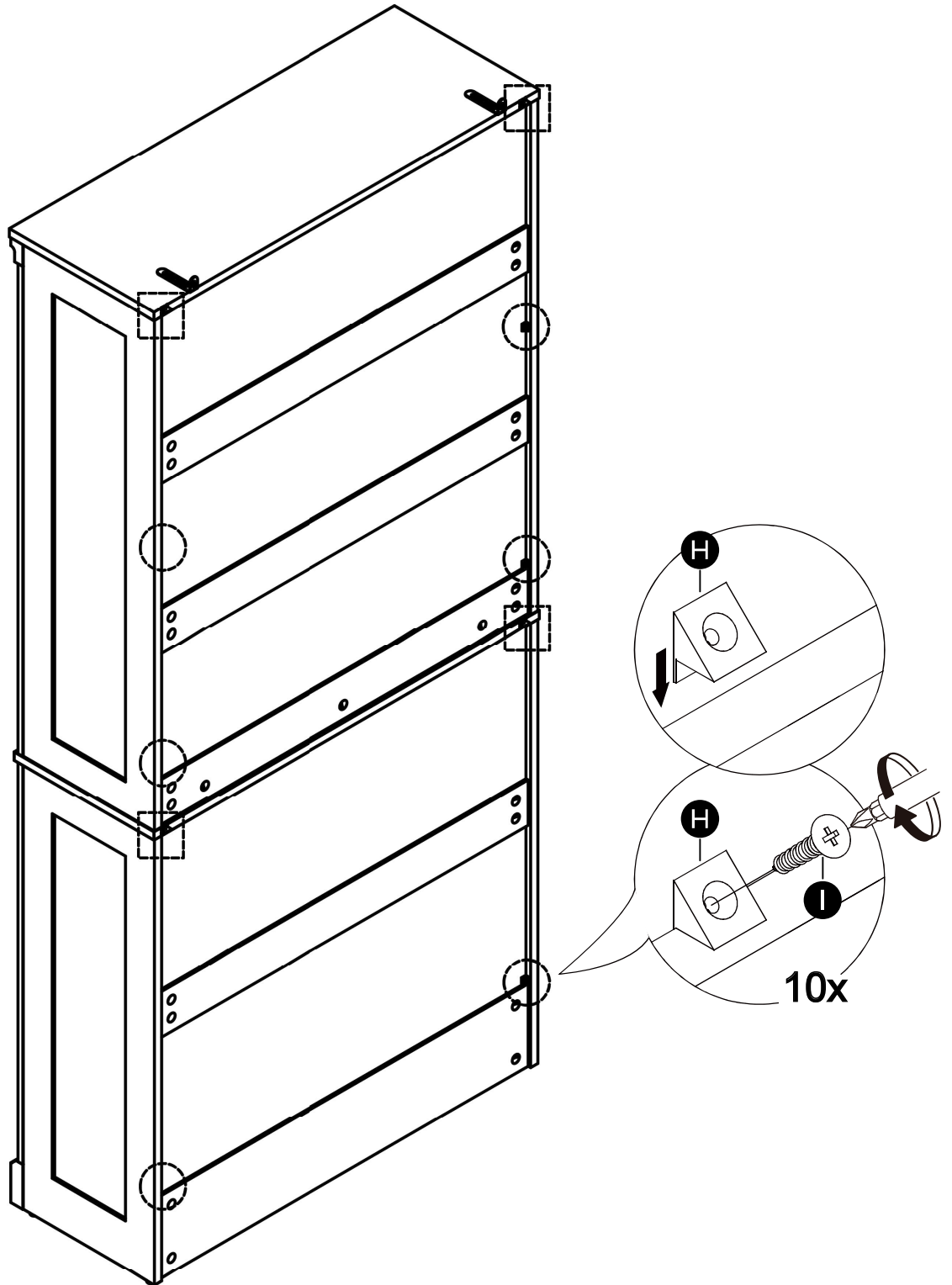

English

The screw and plug supplied can be used with most solid (A) and hollow(B) walls. For solidwood (C) use the screw without plug. If you are uncertain, please seek professional advice.

Deutsch

Das beigelegte Befestigungsmaterial kann für die meisten Massiv- (A) und Hohlwände(B) benutzt werden. Für Massivholzuntergrund (C) Schraube/n ohne Dübel verwenden. Bei Unsicherheit immer fachlichen Rat einholen.

Español







Los tornillos y tacos incluidos se pueden utilizar en la mayor parte de las paredes sólidas (A) o huecas (B). Para la madera maciza (C), usa los tornillos sin tacos. Si tienes dudas, acude a un experto.

Français

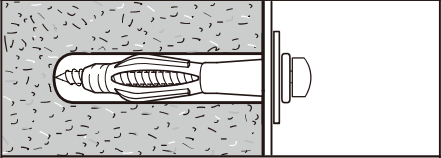
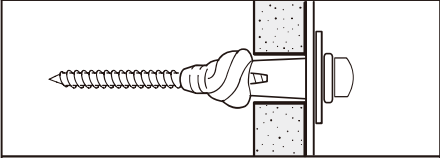
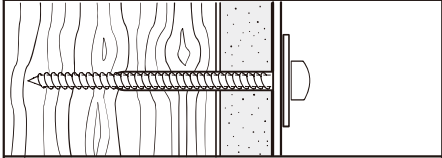
Les vis et les chevilles fournies peuvent être utilisées avec la plupart des murs pleins (A) ou des murs creux (B). Pour le bois massif (C), utiliser les vis sans les chevilles. En cas de doute, adressez-vous à un professionnel qualifié.

Italiano

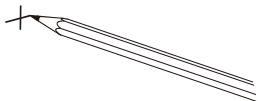
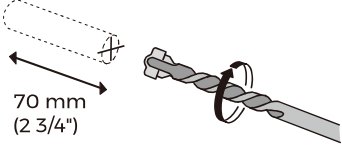
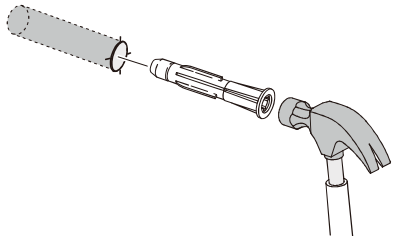
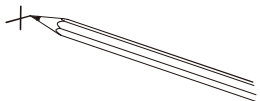
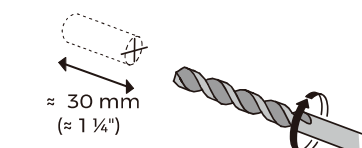
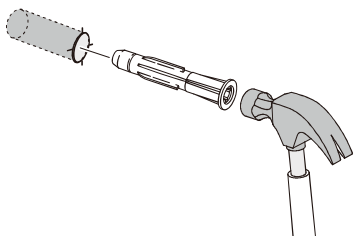
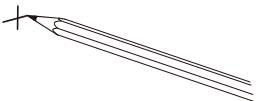
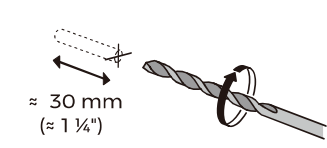
Le viti e i tasselli forniti sono utilizzabili con la maggior parte delle pareti piene (A) e cave (B). Per il legno massiccio (C), usa le viti senza i tasselli. Se hai dubbi, rivolgiti a un esperto.

A	B	C
		
Ø 8 mm (5/16") 	Ø 8 mm (5/16") 	Ø 3 mm (1/8") 
<p>1</p>  <p>2</p>  <p>70 mm (2 3/4")</p> <p>3</p> 	<p>1</p>  <p>2</p>  <p>≈ 30 mm (≈ 1 1/4")</p> <p>3</p> 	<p>1</p>  <p>2</p>  <p>≈ 30 mm (≈ 1 1/4")</p> <p>3</p> 

23

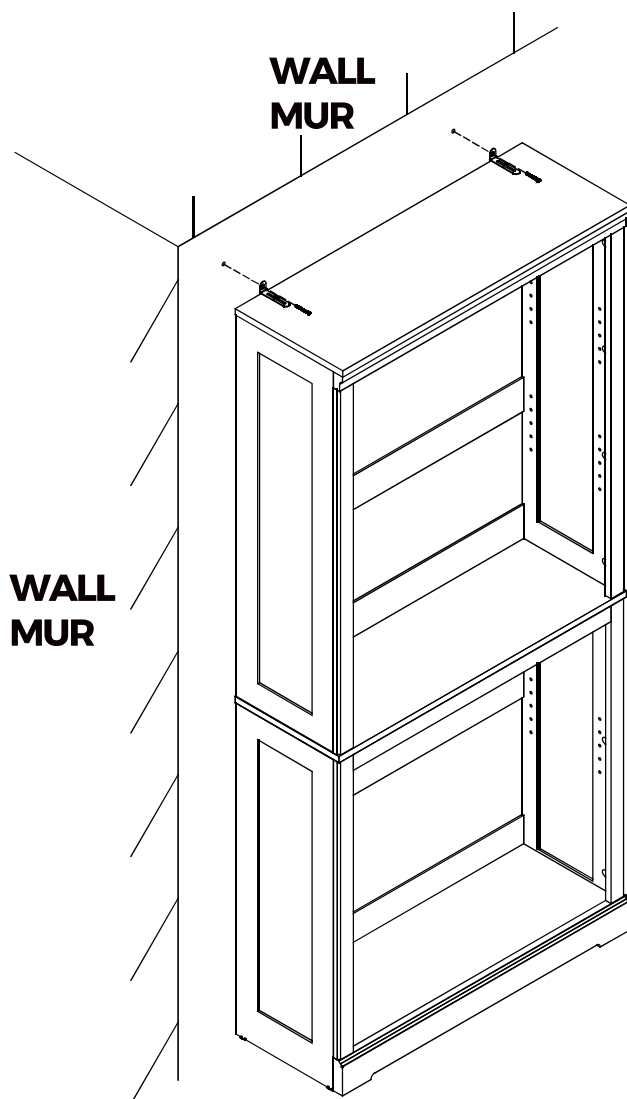

1

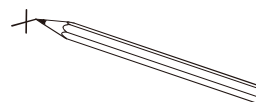

Mark the hole drilling location
Marquer l'emplacement du perçage

2

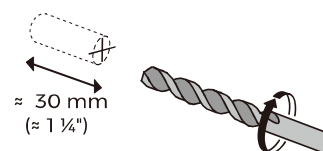

Drill 2 holes
Perçer deux trous

3

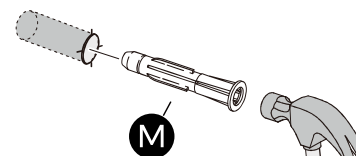

Use a hammer to close anchor
Utiliser un marteau pour enfoncer la cheville d'ancrage

4

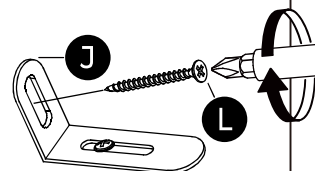

Secure to the wall
Fixer au mur

Step 1: Determine the location of the anti-overturning on the wall and then mark the position after confirming the product has been balanced.

Step 2: Drill the hole on the wall.

Step 3: Use a hammer to fixed the anchor (M) on the wall.

Step 4: Use screw (L) to fix the anti-overturnig(J) on the wall.

Étape 1 : Déterminer l'emplacement du dispositif anti-chute sur le mur, puis marquer la position après avoir vérifié que le produit est bien équilibré.

Étape 2 : Percer le trou dans le mur.

Étape 3 : Utiliser un marteau pour fixer la cheville d'ancrage (M) sur le mur.

Étape 4 : Utiliser la vis (L) pour fixer le dispositif anti-chute (J) sur le mur.

24

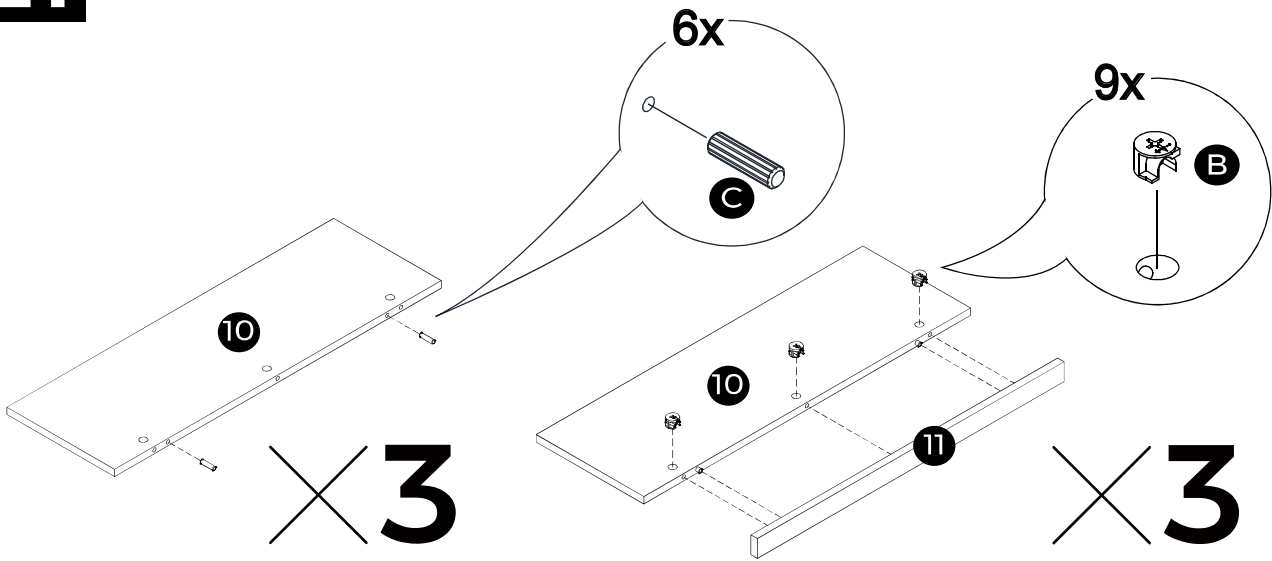

25

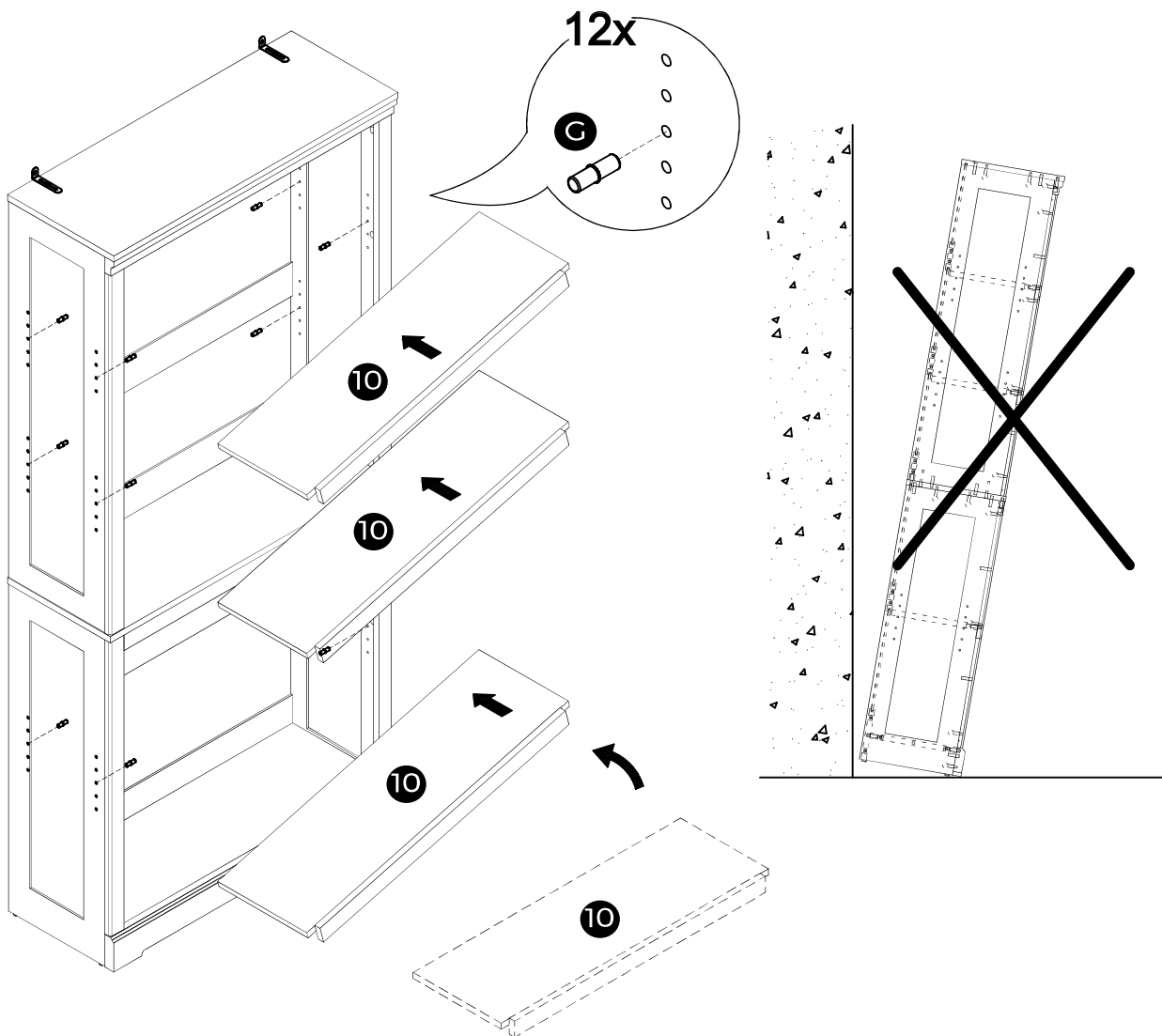

Dear Valued Customer,

Thank you for bringing our products into your life.
Your happiness and satisfaction are at the heart of what we do.
If our products have brightened your day, we're thrilled and eager to share that light further.

Encountering an issue? We're here to help swiftly and effectively.
Here's how you can reach us:

Get in Touch

Email us at:
linsyguest@gmail.com

Share Details

Provide your order number and a photo of the issue, along with a brief description.

Await Solutions

Our team will quickly review and propose the right after-sales solution to make things right.

Your feedback propels us forward.
We're committed to ensuring your purchase experience is always positive.

Warmest thanks,
Customer Service Team

Cher Client Précieux,

Merci d'avoir intégré nos produits dans votre vie.

Votre bonheur et votre satisfaction sont au cœur de notre travail.

Si nos produits ont illuminé votre quotidien, nous sommes ravis et avides de partager cette lumière plus loin.

Vous rencontrez un problème ? Nous sommes là pour vous aider rapidement et efficacement.

Voici comment vous pouvez nous contacter :

Entrer en contact

Nous contacter par email à :
linsyguest@gmail.com

Communiquer les détails

Fournissez votre numéro de commande, une photo du problème ainsi qu'une brève description.

Attendre notre solution

Notre équipe examinera rapidement votre demande et proposera la bonne solution après-vente pour remédier à la situation.

Vos retours nous motive à progresser.

Nous nous engageons à garantir que votre expérience d'achat soit toujours positive.

Chales remerciements,
Équipe de service client