

# Assembly Instructions

**Caution: You must read this before you proceed**

**Please look in the Leg Frame for Hardware packs**

## Chair

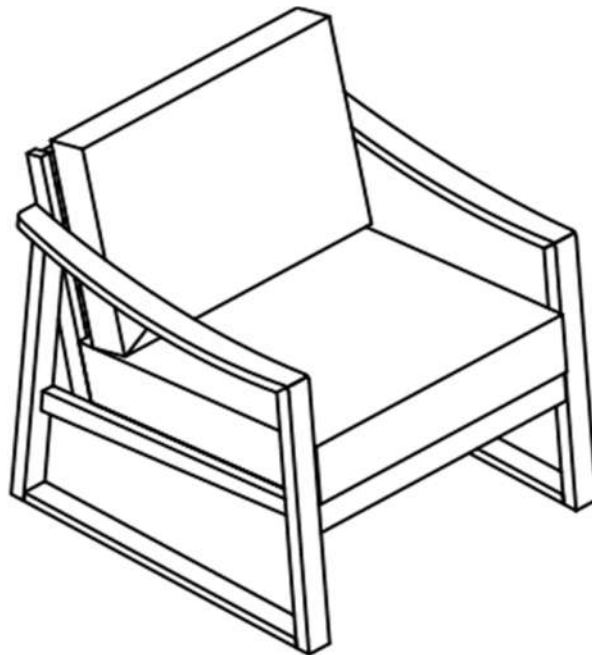

**CAUTION:** This Chair is NOT a TOY.



Keep your child / children at bay during the assembly process.

Whenever lifting or moving the Chair and to prevent damage to the Chair, two adults may be needed to execute these actions.

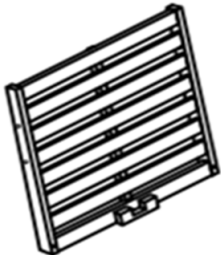
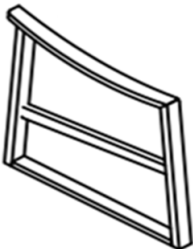
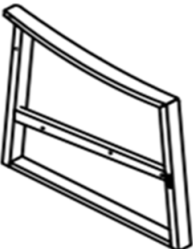
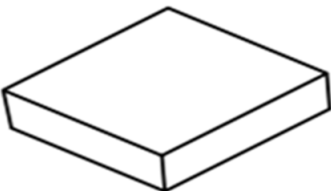
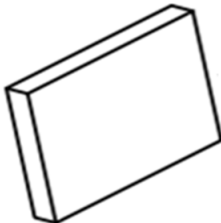
# Part List

Label	Picture	Description	QTY
A	 A rectangular panel with seven horizontal slats, shown from a perspective view.	Seat Panel	1
B	 A rectangular panel with seven horizontal slats and a curved top edge, shown from a perspective view.	Backrest Panel	1
C	 A rectangular frame with a curved top edge and a horizontal support bar, shown from a perspective view.	Left Leg Frame	1
D	 A rectangular frame with a curved top edge and a horizontal support bar, shown from a perspective view.	Right Leg Frame	1
E	 A rectangular cushion with a slightly raised edge, shown from a perspective view.	Seat Cushion	1
F	 A rectangular cushion with a slightly raised edge, shown from a perspective view.	Back cushion	1

# Hardware

Label	Picture	Description	QTY
①		Bolt (M6x35mm)	11
②		Screw (M6x60mm)	3
③		Allen Key	1

# Assembly Preparation

## Before Beginning Assembly:

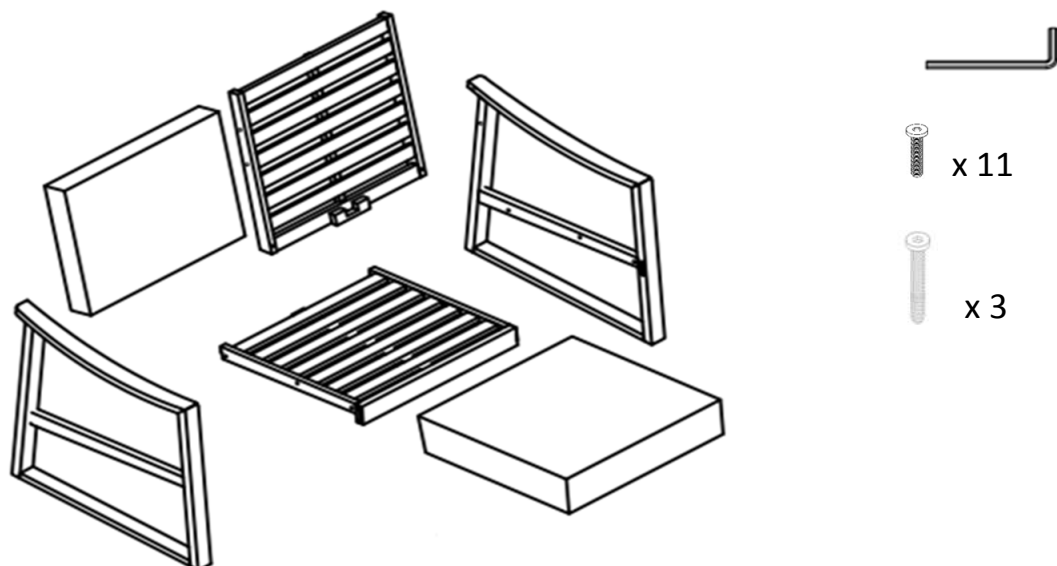

- Read instructions, cover to cover-



- Have 2 adults on hand for assembly-



- Do not assemble on flooring or carpet-



- Assemble on a clean non-marring surface (packing foam)-



- Save all packaging until finished-

# Assembly Steps

## Overview

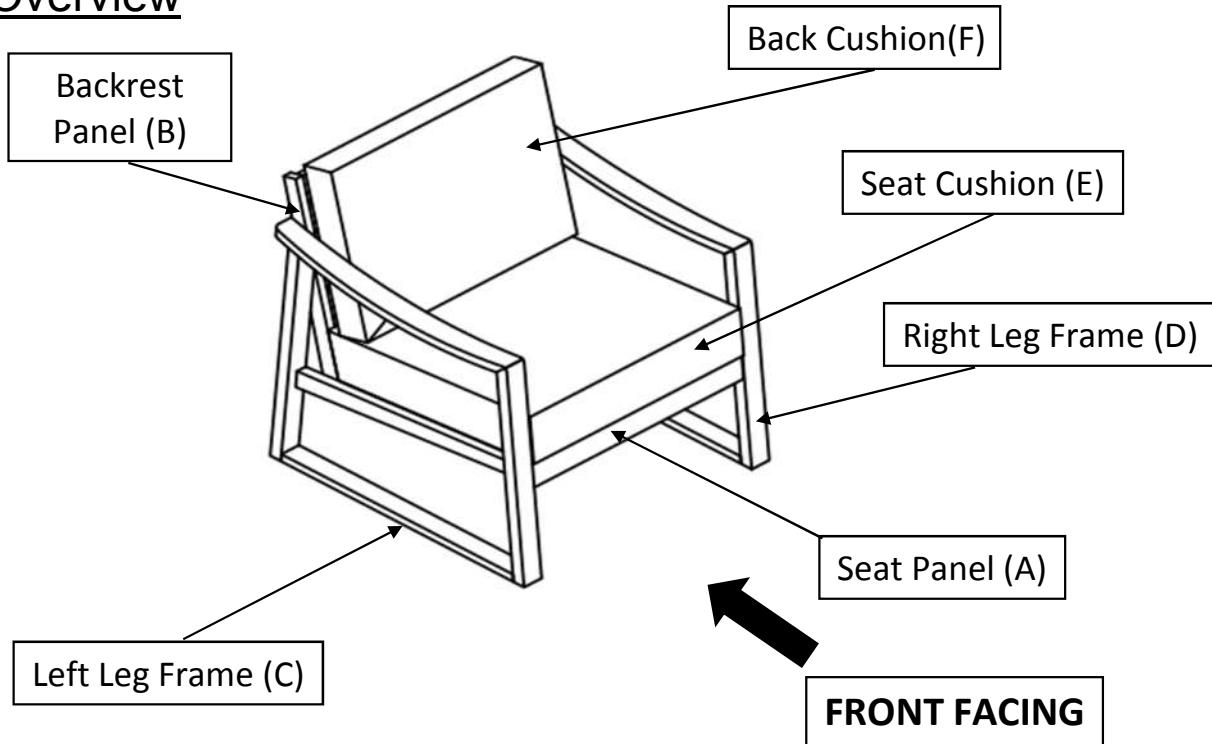

This Chair has multiple parts and may require up to 30 minutes to assemble. To give you an overview of the Chair parts, the above picture is to help you put the various parts into perspective. Please read through the instructions below to familiarise yourself with the parts and steps before assembly.

## Step 1

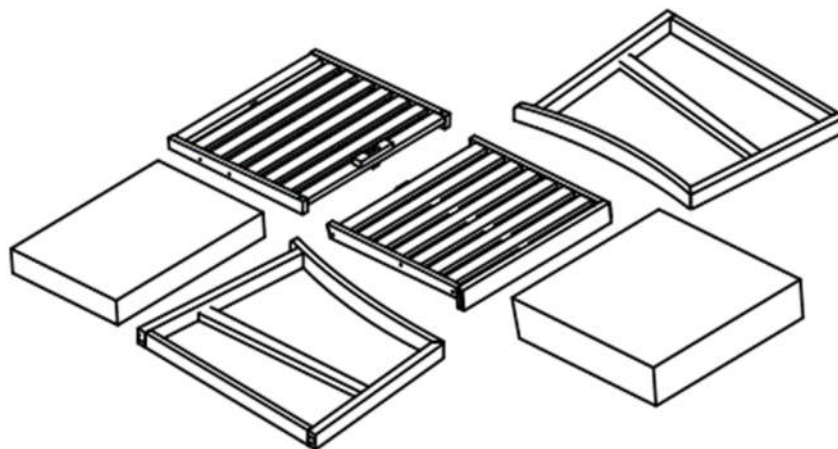

Unpack and place all parts on a clean, non-marring surface.

## Step 2

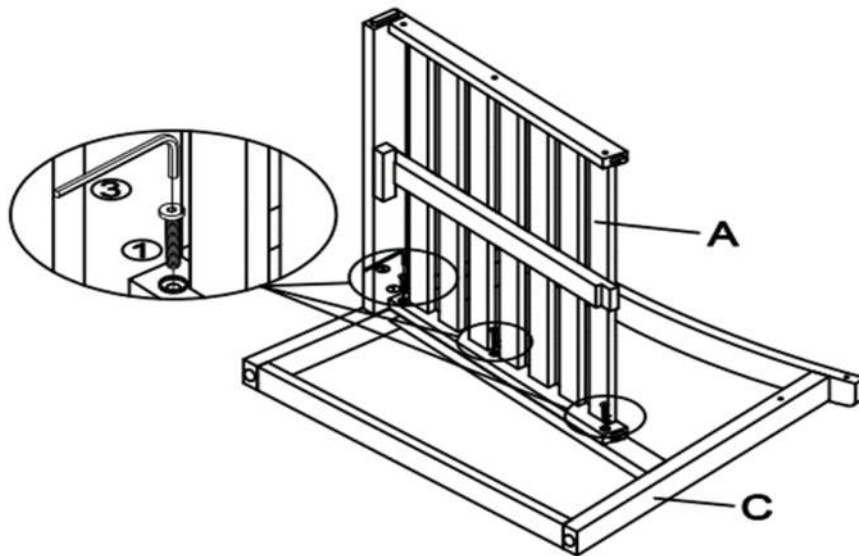

With assistance from your adult partner, position the Seat Panel(A) to the Left Leg Frame(C) as shown in the above picture.

Using 3 Bolts(①) and the Allen Key(③) attach the Seat Panel(A) to the Left Leg Frame(C) as pictured.

**Do not fully tighten the Bolts.**

## Step 3

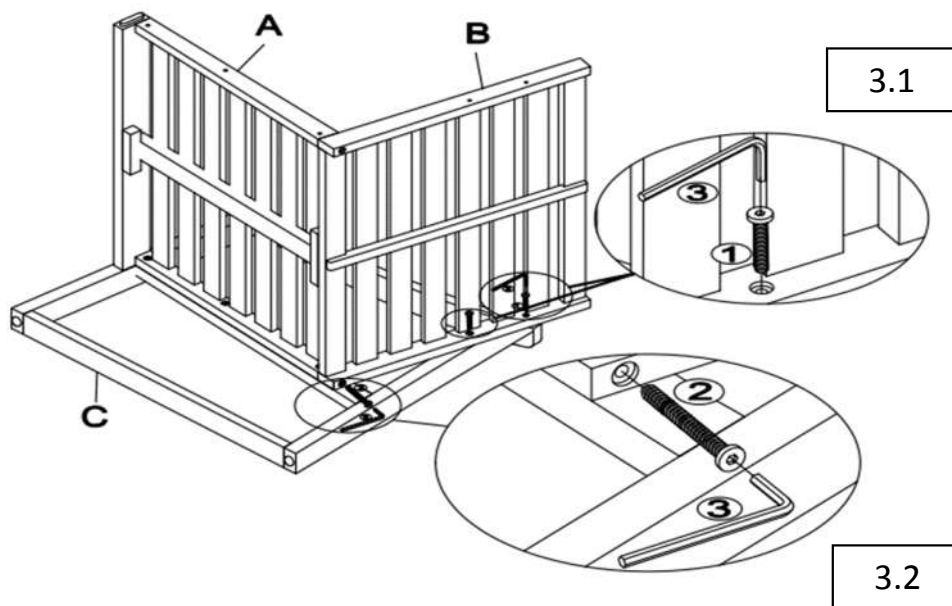

With assistance from your adult partner, position the Backrest Panel(B) to the assembled parts in Step 2 as shown in the above picture.

3.1) Using 2 Bolts(①) and the Allen Key(③) attach the Backrest Panel(B) to the Left Leg Frame(C) as pictured.

3.2) Using a Screw(②) and the Allen Key(③) attach the Backrest Panel(B) to the Seat Panel(A) as pictured.

**Do not fully tighten the Bolts and Screw.**

## Step 4

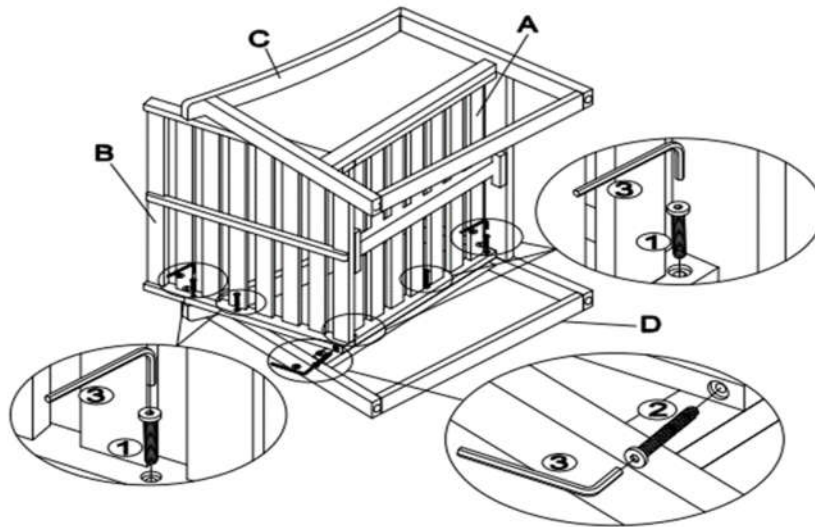

With assistance from your adult partner, turn the assembled parts in Step 3 to its other side.

Repeat the same process in Step 2 and Step 3 to attach Right Leg Frame(D) to Seat Panel(A) and Backrest Panel(B).

**Do not fully tighten the Bolts and Screws.**

## Step 5

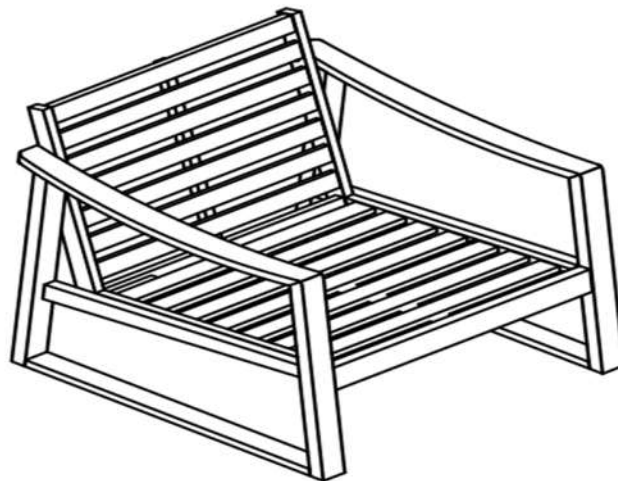

Stand the Chair up with the assistance from your adult partner.

Exert pressure floorwards onto the Chair with both your hands.

This pressure will help the Legs and Chair reach full alignment status.

Check for wobbles on a LEVEL surface.

If no wobbles are found proceed to tighten the Bolts and Screws in a sequential manner, until evenly secured.

When tightening the Bolts and Screws, tighten sequentially.

**Do not tighten any Bolt and Screw fully and then move on towards the next one.**

**If there are still wobbles after tightening, loosen the Bolts and Screws and execute the same above process.**

## Step 6

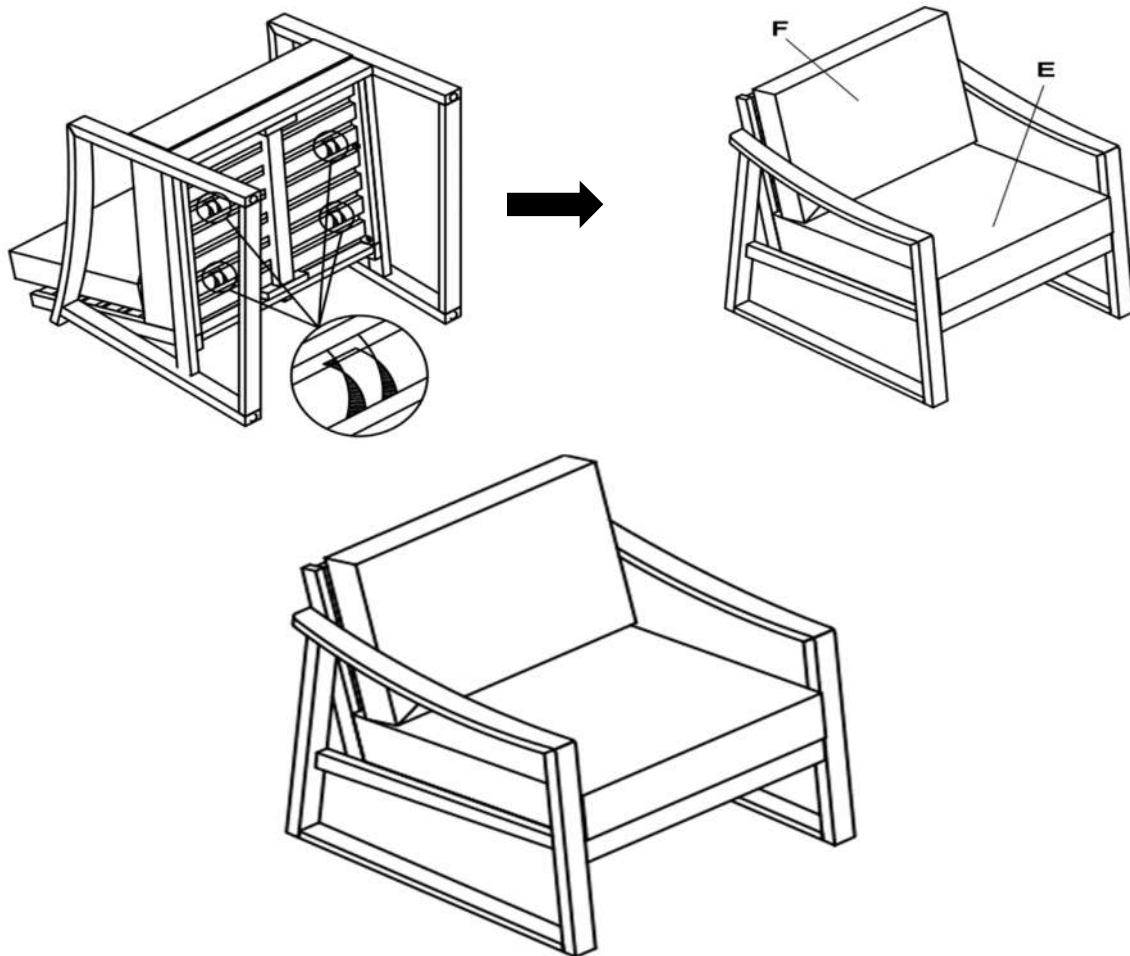

Place the Seat Cushion(E) onto the Chair, then tie the velcro of the Seat Cushion (E) to the Chair as shown in the above picture.

Turn the Chair right side up, place the Back Cushion (F) on the Chair as shown in the above picture.

**Your Chair is ready for use.**

**This Chair can only be used on a flat, level surface.**

## Care & Maintenance

-  ● Do not put hot items directly on furniture surface
  -  ● Do not clean furniture with harsh cleansers or polish.
  -  ● To obtain the longest lifespan of your outdoor products, minimizing exposure to direct sunlight is recommended.
  -  ● Children should not climb or jump on the furniture.
  -  ● Do not write on furniture without a padded barrier to protect the surface.
  -  ● To obtain the longest lifespan of your outdoor products, avoid extended and lengthy exposure to rain, snow, and direct sunshine. Whenever possible cover the product and /or place under patio or awnings.
  -  ● Not for commercial use. For residential use only .
  -  ● Stains may be removed with mild soap solution and damp cloth.
- 
-  ● Dust and pick-up spills using a clean, non-colored, lint-free cloth .